



6N70K-MTQ

Power MOSFET

6.0A, 700V N-CHANNEL POWER MOSFET

DESCRIPTION

The UTC **6N70K-MTQ** is an N-channel mode power MOSFET using UTC's advanced technology to provide customers with a minimum on-state resistance, high switching speed, low gate charge and low input capacitance.

The UTC **6N70K-MTQ** is universally applied in high efficiency switch mode power supply.

FEATURES

- * $R_{DS(ON)} < 2.4\Omega$ @ $V_{GS} = 10V$, $I_D = 3A$
- * High switching speed

SYMBOL

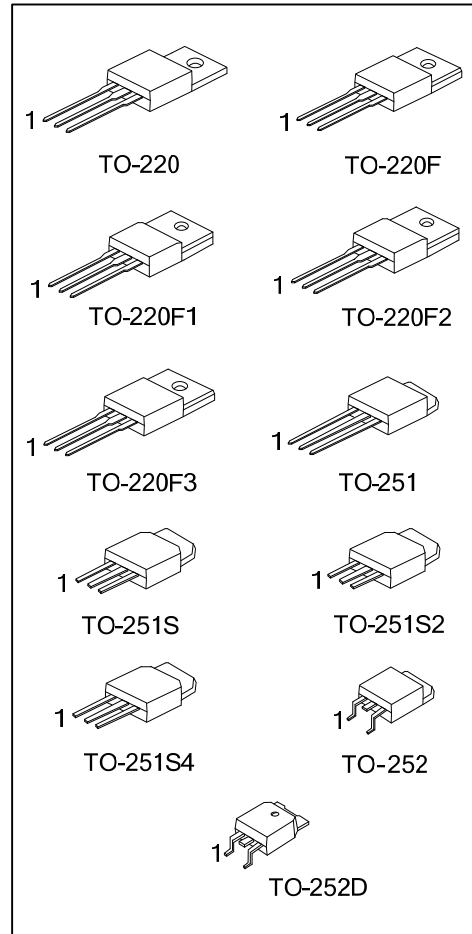
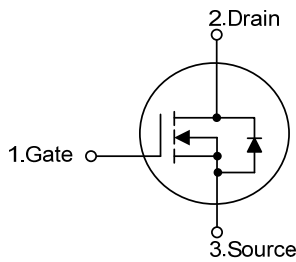

ORDERING INFORMATION

Ordering Number		Package	Pin Assignment			Packing
Lead Free	Halogen Free		1	2	3	
6N70KL-TA3-T	6N70KG-TA3-T	TO-220	G	D	S	Tube
6N70KL-TF3-T	6N70KG-TF3-T	TO-220F	G	D	S	Tube
6N70KL-TF1-T	6N70KG-TF1-T	TO-220F1	G	D	S	Tube
6N70KL-TF2-T	6N70KG-TF2-T	TO-220F2	G	D	S	Tube
6N70KL-TF3-T	6N70KG-TF3-T	TO-220F3	G	D	S	Tube
6N70KL-TM3-T	6N70KG-TM3-T	TO-251	G	D	S	Tube
6N70KL-TMS-T	6N70KG-TMS-T	TO-251S	G	D	S	Tube
6N70KL-TMS2-T	6N70KG-TMS2-T	TO-251S2	G	D	S	Tube
6N70KL-TMS4-T	6N70KG-TMS4-T	TO-251S4	G	D	S	Tube
6N70KL-TN3-R	6N70KG-TN3-R	TO-252	G	D	S	Tape Reel
6N70KL-TND-R	6N70KG-TND-R	TO-252D	G	D	S	Tape Reel

Note: Pin Assignment: G: Gate D: Drain S: Source

<p>6N70KL-TA3-T</p> <p>(1) Packing Type</p> <p>(2) Package Type</p> <p>(3) Green Package</p>	<p>(1) T: Tube, R: Tape Reel</p> <p>(2) TA3: TO-220, TF3: TO-220F, TF1: TO-220F1, TF2: TO-220F2, TF3: TO-220F3, TM3: TO-251 TMS: TO-251S, TMS2: TO-251S2, TMS4: TO-251S4, TN3: TO-252, TND: TO-252D</p> <p>(3) L: Lead Free, G: Halogen Free and Lead Free</p>
--	--

MARKING

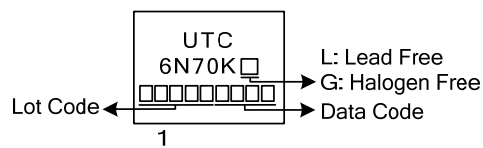

■ ABSOLUTE MAXIMUM RATINGS ($T_C=25^\circ\text{C}$, unless otherwise specified)

PARAMETER		SYMBOL	RATINGS	UNIT		
Drain-Source Voltage		V_{DSS}	700	V		
Gate-Source Voltage (Note 2)		V_{GSS}	± 30	V		
Drain Current	Continuous $T_C=25^\circ\text{C}$	I_D	6	A		
	Pulsed	I_{DM}	24	A		
Avalanche Current (Note 2)		I_{AR}	6	A		
Avalanche Energy	Single Pulsed (Note 3)	E_{AS}	75	mJ		
Peak Diode Recovery dv/dt (Note 4)		dv/dt	2.5	V/ns		
Power Dissipation	TO-220	P_D	125	W		
	TO-220F/TO-220F1 TO-220F2/TO-220F3		42			
	TO-251/TO-251S TO-251S2/TO-251S4 TO-252/TO-252D		55			
	TO-220		1			
Linear Derating Factor	TO-220F		0.32	W/ $^\circ\text{C}$		
	TO-220F1/TO-220F2 TO-220F3		0.336			
	TO-251/TO-251S TO-251S2/TO-251S4 TO-252/TO-252D		0.44			
	Junction Temperature		T_J		+150	$^\circ\text{C}$
	Storage Temperature		T_{STG}		-55~+150	$^\circ\text{C}$

Notes: 1. Absolute maximum ratings are those values beyond which the device could be permanently damaged.

Absolute maximum ratings are stress ratings only and functional device operation is not implied.

2. Repetitive Rating: Pulse width limited by maximum junction temperature

3. $L = 5\text{mH}$, $I_{AS} = 5.5\text{A}$, $V_{DD} = 50\text{V}$, $R_G = 25\Omega$, Starting $T_J = 25^\circ\text{C}$

4. $I_{SD} \leq 6\text{A}$, $di/dt \leq 140\text{A}/\mu\text{s}$, $V_{DD} \leq BV_{DSS}$, Starting $T_J = 25^\circ\text{C}$

■ THERMAL DATA

PARAMETER		SYMBOL	RATINGS	UNIT
Junction to Ambient	TO-220/TO-220F TO-220F1/TO-220F2 TO-220F3	θ_{JA}	62.5	$^\circ\text{C}/\text{W}$
	TO-251/TO-251S TO-251S2/TO-251S4 TO-252/TO-252D		110	
Junction to Case	TO-220	θ_{JC}	3.1	$^\circ\text{C}/\text{W}$
	TO-220F		1.0	
	TO-220F1/TO-220F2 TO-220F3		2.9	
	TO-251/TO-251S TO-251S2/TO-251S4 TO-252/TO-252D		2.27	

■ ELECTRICAL CHARACTERISTICS ($T_C=25^\circ\text{C}$, unless otherwise specified)

PARAMETER	SYMBOL	TEST CONDITIONS	MIN	TYP	MAX	UNIT
OFF CHARACTERISTICS						
Drain-Source Breakdown Voltage	BV_{DSS}	$I_D=250\mu\text{A}$, $V_{GS}=0\text{V}$	700			V
Breakdown Voltage Temperature Coefficient	$\Delta BV_{DSS}/\Delta T_J$	$I_D=250\mu\text{A}$		0.79		$V/^\circ\text{C}$
Drain-Source Leakage Current	I_{DSS}	$V_{DS}=700\text{V}$, $V_{GS}=0\text{V}$			1	μA
		$V_{DS}=560\text{V}$, $T_C=125^\circ\text{C}$			250	μA
Gate-Source Leakage Current	Forward	$V_{GS}=+30\text{V}$, $V_{DS}=0\text{V}$			+100	nA
	Reverse	$V_{GS}=-30\text{V}$, $V_{DS}=0\text{V}$			-100	nA
ON CHARACTERISTICS						
Gate Threshold Voltage	$V_{GS(TH)}$	$V_{DS}=V_{GS}$, $I_D=250\mu\text{A}$	2.0		4.0	V
Static Drain-Source On-State Resistance	$R_{DS(ON)}$	$V_{GS}=10\text{V}$, $I_D=3\text{A}$ (Note 1)		2.0	2.4	Ω
DYNAMIC PARAMETERS						
Input Capacitance	C_{ISS}	$V_{GS}=0\text{V}$, $V_{DS}=25\text{V}$, $f=1.0\text{MHz}$ (Note 1, 2)		480		pF
Output Capacitance	C_{OSS}			65		pF
Reverse Transfer Capacitance	C_{RSS}			7.5		pF
SWITCHING PARAMETERS						
Turn-ON Delay Time	$t_{D(ON)}$	$V_{DD}=30\text{V}$, $I_D=0.5\text{A}$, $R_G=25\Omega$ $V_{GS}=10\text{V}$		70		ns
Rise Time	t_R			61		ns
Turn-OFF Delay Time	$t_{D(OFF)}$			140		ns
Fall-Time	t_F			41		ns
Total Gate Charge	Q_G	$V_{GS}=10\text{V}$, $V_{DS}=50\text{V}$, $I_D=1.3\text{A}$, $I_G=100\mu\text{A}$ (Note 1, 2)		45		nC
Gate to Source Charge	Q_{GS}			7		nC
Gate to Drain Charge	Q_{GD}			7		nC
SOURCE- DRAIN DIODE RATINGS AND CHARACTERISTICS						
Maximum Body-Diode Continuous Current	I_S	Integral reverse pn-diode in the MOSFET			6	A
Maximum Body-Diode Pulsed Current (Note 3)	I_{SM}				24	A
Drain-Source Diode Forward Voltage (Note 2)	V_{SD}	$I_S=6\text{A}$, $V_{GS}=0\text{V}$, $T_J = 25^\circ\text{C}$			1.4	V

- Notes: 1. Pulse Test: Pulse width $\leq 250\mu\text{s}$, Duty cycle $\leq 2\%$
 2. Essentially independent of operating temperature
 3. Repetitive Rating: Pulse width limited by maximum junction temperature

TEST CIRCUITS AND WAVEFORMS

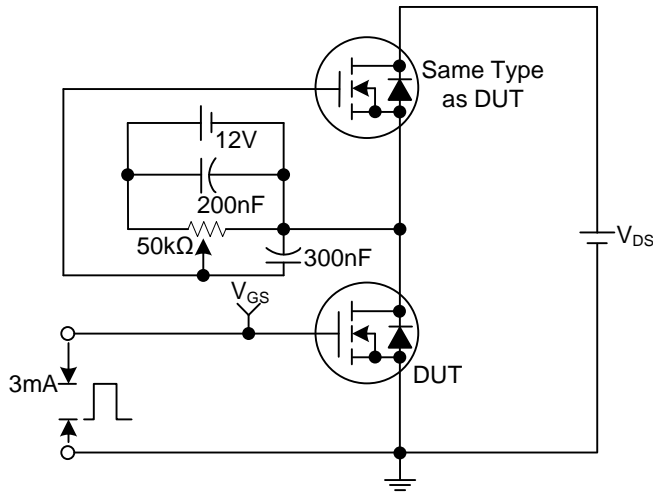

Gate Charge Test Circuit

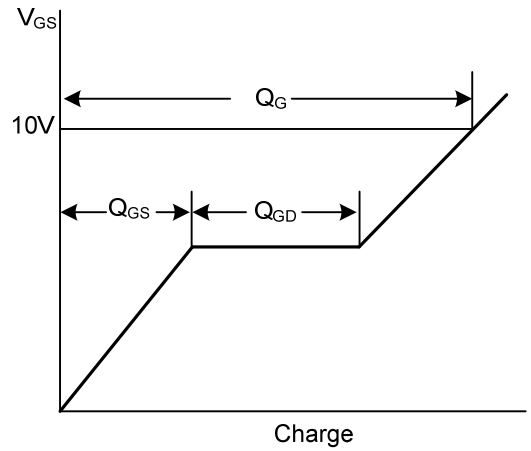

Gate Charge Waveforms

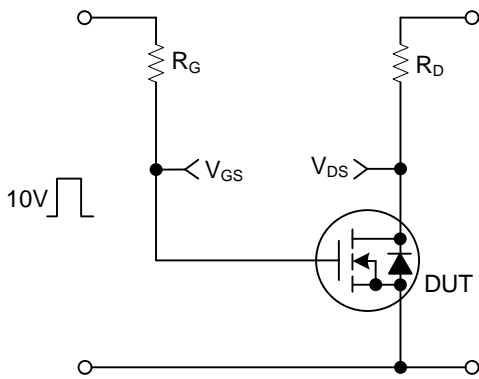

Resistive Switching Test Circuit

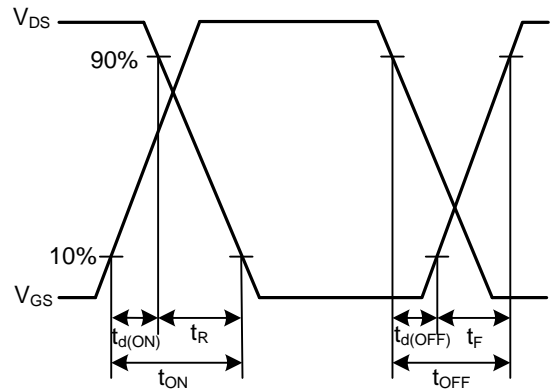

Resistive Switching Waveforms

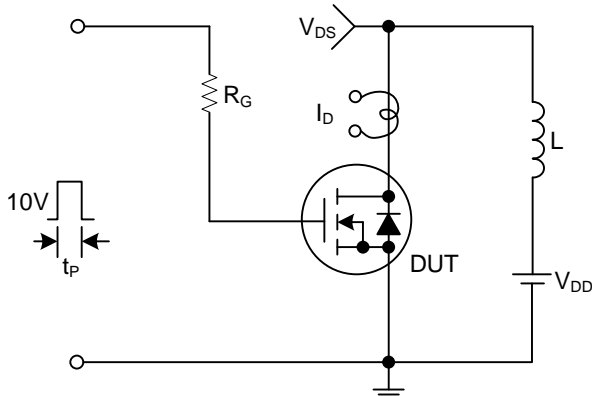

Unclamped Inductive Switching Test Circuit

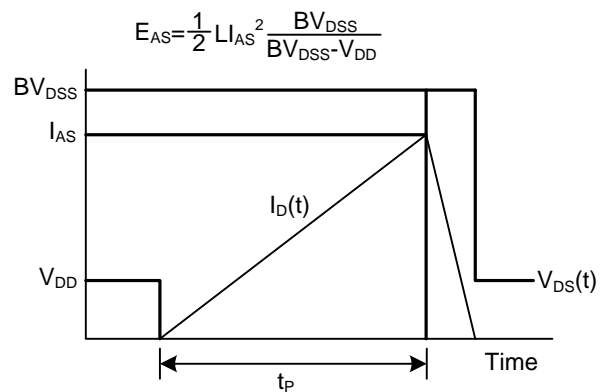

Unclamped Inductive Switching Waveforms

■ TEST CIRCUITS AND WAVEFORMS(Cont.)

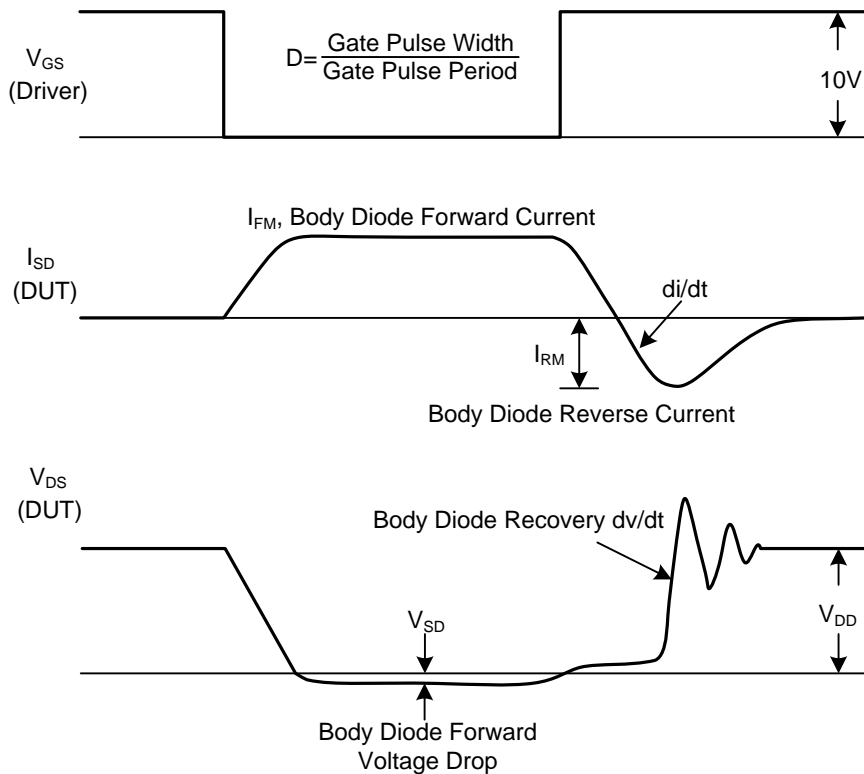
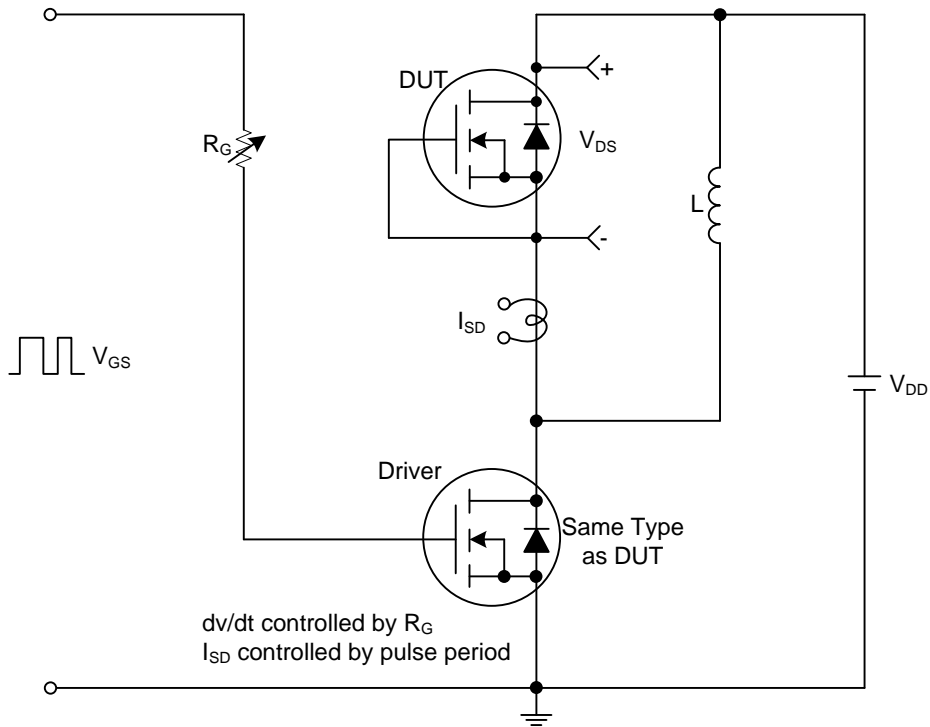

Peak Diode Recovery dv/dt Test Circuit and Waveforms

■ TYPICAL CHARACTERISTICS

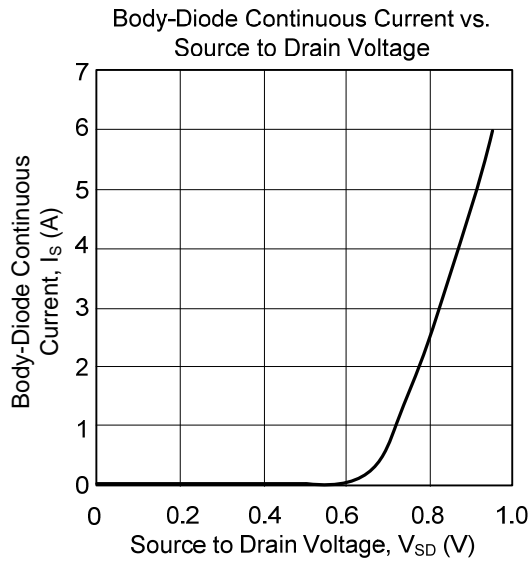

UTC assumes no responsibility for equipment failures that result from using products at values that exceed, even momentarily, rated values (such as maximum ratings, operating condition ranges, or other parameters) listed in products specifications of any and all UTC products described or contained herein. UTC products are not designed for use in life support appliances, devices or systems where malfunction of these products can be reasonably expected to result in personal injury. Reproduction in whole or in part is prohibited without the prior written consent of the copyright owner. The information presented in this document does not form part of any quotation or contract, is believed to be accurate and reliable and may be changed without notice.