

Dual Output Super-mini Signal Conditioners Pico-M Series

SIGNAL CONVERTER

(PC programmable, CE)

Functions & Features

- Converts a DC input into two isolated process signals
- PC programmable
- Space-saving, easy-to-maintain, multi-channel installation base

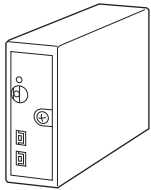

MODEL: M8XV3-[1][2]-R[3]

ORDERING INFORMATION

- Code number: M8XV3-[1][2]-R[3]

Specify a code from below for each of [1] through [3].

- (e.g. M8XV3-S2V2V2-R/Q)
- Input range (e.g. 0 - 5 V DC)
- Output 1 / Output 2 (e.g. 1 - 5 V / 1 - 5 V DC)

If no specifications are specified, model M8XV3-S2V2V2-R/Q will be shipped.

[S2: 1 - 5 V DC, V2V2: 1 - 5 V DC / 1 - 5 V DC]

- Use Ordering Information Sheet (No. ESU-5469) to specify linearization data when the I/O signals are nonlinear. Linear data will be programmed if not otherwise specified.
- Specify the specification for option code /Q (e.g. /C01)

[1] INPUT

Current

Z1: Range 0 - 50 mA DC (Input resistance 25 Ω)

Voltage

S1: Range -1 - +1 V DC (Input resistance 1 MΩ min.)

S2: Range -10 - +10 V DC (Input resistance 1 MΩ min.)

(Configurator software is used to change input over the described range of the selected suffix code.

For changing between suffix codes, set the Input Range Selector on the side of unit before software adjustment.)

[2] OUTPUT 1 / OUTPUT 2

V2Z1: Range -10 - +10 V DC / Range 0 - 20 mA DC

V2V2: Range -10 - +10 V DC / Range -10 - +10 V DC

(Configurator software is used to change output over the described range of the selected suffix code.

For changing between suffix codes, set the Output Range Selector on the side of unit before software adjustment.)

POWER INPUT

DC Power

R: 24 V DC

(Operational voltage range 24 V ±10 %, ripple 10 %p-p max.)

[3] OPTIONS

blank: none

/Q: With options (specify the specification)

SPECIFICATIONS OF OPTION: Q

COATING (For the detail, refer to M-System's web site.)

/C01: Silicone coating

/C02: Polyurethane coating

/C03: Rubber coating

RELATED PRODUCTS

- Installation Base or Single Mount Base Socket (model: M8BSx)

This unit must be mounted on dedicated base or socket.

- PC configurator software (model: JXCON)

Downloadable at M-System's web site.

A dedicated cable is required to connect the module to the PC. Please refer to the internet software download site or the users manual for the PC configurator for applicable cable types.

GENERAL SPECIFICATIONS

Construction: Plug-in

Mounting screw: M3 screw (torque 0.3 N·m)

Housing material: Flame-resistant resin (black)

Power supply: Via the Installation Base terminals (model: M8BSx)

Isolation: Input to output 1 to output 2 to power

Overrange output: Approx. -15 to +115 %

Manual zero adjustments: -5 to +5 %

(factory setting: 0 %)

Manual span adjustments: 95 to 105 %

(factory setting: 100 %)

Programming: Downloaded from PC; input range, output range, zero and span, simulating output, linearization, etc.

Status indicator LED: Blinking patterns indicate different operating status of the transmitter.

Configurator connection: 2.5 dia. miniature jack; RS-232-C level

INPUT SPECIFICATIONS

■ **DC Current:** 0 – 50 mA DC;

Input resistor incorporated

(If not specified, the input range is 4 – 20 mA DC.)

Operational range: 0 – 70 mA DC

Minimum span: 2 mA

Offset: Lower range can be any specific value within the input range provided that the minimum span is maintained.

■ **DC Voltage:** -10 – +10 V DC

Operational range: -11.5 – +11.5 V DC

Minimum span: 10 mV for S1; 100 mV for S2

Offset: Lower range can be any specific value within the input range provided that the minimum span is maintained.

If not specified, the input range is shown below.

S1: 0 – 100 mV DC

S2: 1 – 5 V DC

OUTPUT SPECIFICATIONS

■ **DC Current:** 0 – 20 mA DC

Operational range: 0 – 24 mA DC

Minimum span: 1 mA

Offset: Lower range can be any specific value within the output range provided that the minimum span is maintained.

Load resistance: Output drive 6 V max.

(e.g. 4 – 20 mA: 300 Ω [6 V ÷ 20 mA])

■ **DC Voltage:** -10 – +10 V DC

Operational range: -11.5 – +11.5 V DC

Minimum span: 1 V

Offset: Lower range can be any specific value within the output range provided that the minimum span is maintained.

Load resistance: Output drive 1 mA max.

(e.g. 1 – 5 V: 5000 Ω [5 V ÷ 1 mA])

If not specified, the output range is shown below.

V2Z1: 1 – 5 V / 4 – 20 mA DC

V2V2: 1 – 5 V / 1 – 5 V DC

INSTALLATION

Current consumption: Approx. 50 mA (70 mA for current output)

Operating temperature: 0 to 55°C (32 to 131°F)

Operating humidity: 30 to 95 %RH (non-condensing)

Mounting: Installation Base (model: M8BSx)

Weight: 70 g (2.5 oz)

PERFORMANCE

Overall accuracy:

Input accuracy + output accuracy [gain ≤ 1]

(inp. accuracy + out. accuracy) × gain [gain > 1]

Inversely proportional to the span.

Except the accuracy of input resistor.

See CALCULATION EXAMPLES OF OVERALL ACURACY.

• **Input accuracy:** (% of max. input range)

-1 – +1 V : ±0.02 %

-10 – +10 V : ±0.01 %

0 – 50 mA : ±0.02 %

• **Output accuracy:** (% of output range)

-10 – +10 V: ±0.02 %

0 – 20 mA: ±0.04 %

Temp. coefficient: ±0.015 %/°C (±0.008 %/°F) of I/O range at 0 to 55°C [32 to 131°F]

Response time: ≤ 0.9 sec. (0 – 90 %)

Line voltage effect: ±0.1 % over voltage range

Insulation resistance: ≥ 100 MΩ with 500 V DC

Dielectric strength:

1500 V AC @1 minute (input to output 1 or output 2 or power to ground)

500 V AC @1 minute (output 1 to output 2 to power)

HOW TO CALCULATE THE ACCURACY

■ **Overall Accuracy**

[Example] 1 – 5 V input, 1 – 5 V output

Input Accuracy

= Max. Range ÷ Input Span × Input Accuracy

= 20 ÷ 4 × 0.01 = 0.05

Output Accuracy

= Max. Range ÷ Output Span × Output Accuracy

= 20 ÷ 4 × 0.02 = 0.1

Overall Accuracy = 0.05 + 0.1 = ±0.15 %

STANDARDS & APPROVALS

EU conformity:

EMC Directive

EMI EN 61000-6-4

EMS EN 61000-6-2

RoHS Directive

EN 50581

EXTERNAL VIEWS

■ SIDE VIEW

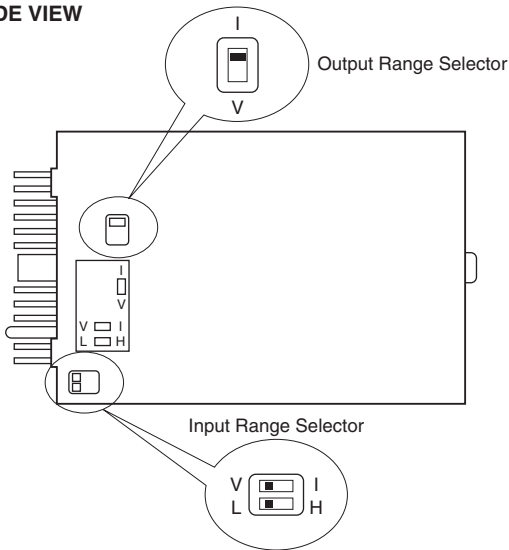

■ FRONT VIEW

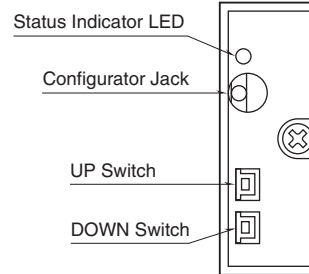

■ BOTTOM VIEW

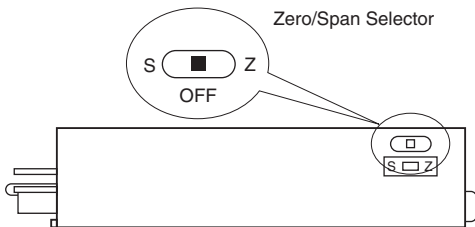

Input Range Selector

(SW POSITION: RANGE)

I / L: Z1 (0 - 50 mA DC)

V / L: S1 (-1 - +1 V DC)

V / H: S2 (-10 - +10 V DC)

Output Range Selector

(SW POSITION: RANGE)

I: V2Z1 (-10 - +10 V / 0 - 20 mA DC)

V: V2V2 (-10 - +10 V / -10 - +10 V DC)

Zero/Span Selector

(SW POSITION: MODE)

S: SPAN

Center: OFF

Z: ZERO

Zero/Span is calibrated by using UP/DOWN switches when the calibration mode is set. Refer to the instruction manual for detailed procedures.

EXTERNAL DIMENSIONS unit: mm (inch)

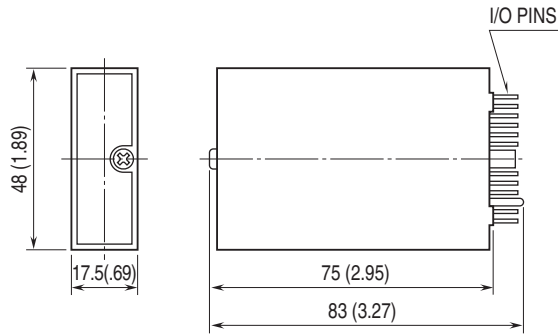

SCHEMATIC CIRCUITRY & CONNECTION DIAGRAM

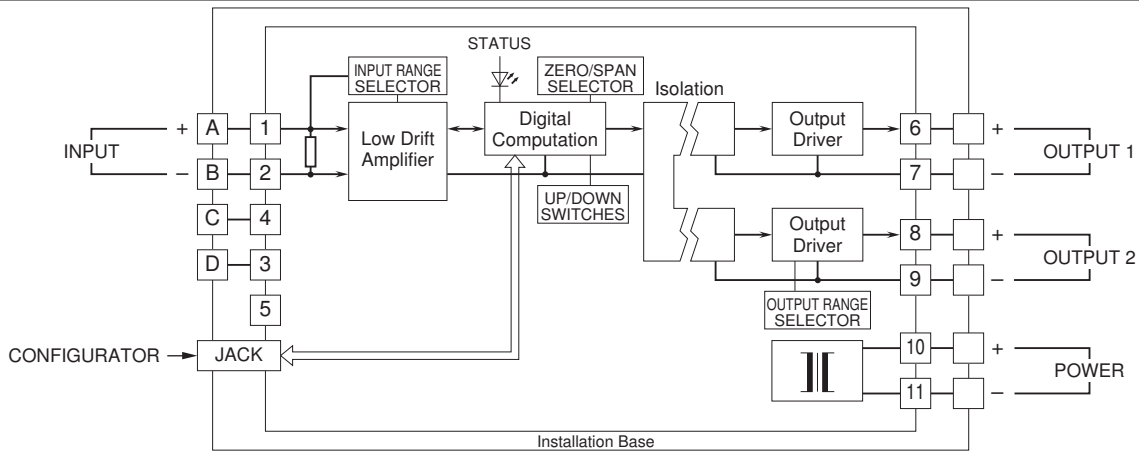

Specifications are subject to change without notice.