

RECOMMENDED PANEL MOUNTING

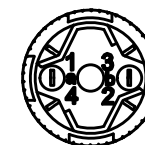
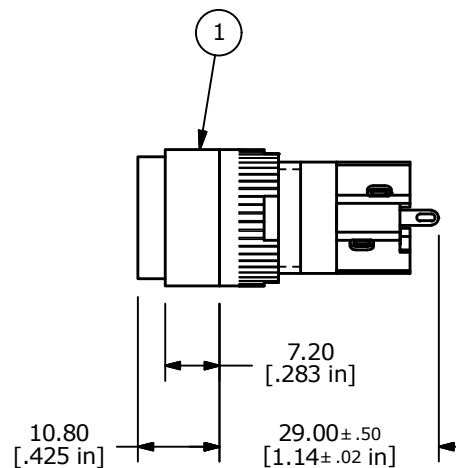
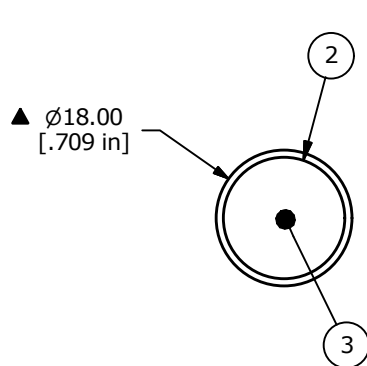
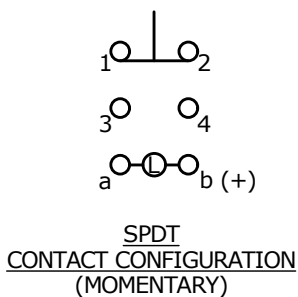

NOTE:

1. ALL DIMENSIONS IN MM [INCH].
2. GENERAL TOLERANCE: X.X = ±0.4  
X.XX = ±0.25
3. TERMINAL NUMBERS FOR REF ONLY.
- ▲ 4. CONTACT RATING: 5A @ 250VAC  
8A @ 125VAC  
6A @ 24VDC
5. ELECTRICAL LIFE: 50,000 OPERATIONS
6. INSULATION RESISTANCE: 1,000 MEGA-OHM MIN.
- ▲ 7. CONTACT MATERIAL: SILVER PLATED COPPER ALLOY
8. ACTUATION FORCE: 300g / POLE
9. OPERATING TEMP.: -25°C to +55°C
10. ▲ DENOTES CRITICAL PARAMETER.
- ▲ 11. LAMP VOLTAGE: 6V AC/DC 200mA INCANDESCENT
12. 2011/65/EU (ROHS) COMPLIANT

PARTS LIST			
ITEM	QTY	PART NUMBER	DESCRIPTION
1	1	F040009	D160AR11
2	1	F050114	50-001-14 RED Flat Round LENS
3	1	F050402	50-004-02 6V AC/DC 200mA Incandescent



B	22716	UPDATED AND REDRAWN	2/10/17	MW
REV	PCR NO	DESCRIPTION	DATE	BY

TITLE D160AR11ARED				
SCALE 1:1	DATE 2/10/2017	DR MW	DWG XF0375P	REV B

THE INFORMATION CONTAINED IN THIS DOCUMENT IS PROPRIETARY TO E-SWITCH AND IS NOT TO BE COPIED OR TRANSFERRED