

DASH NO.	M CODE	MADE FROM
----------	--------	-----------

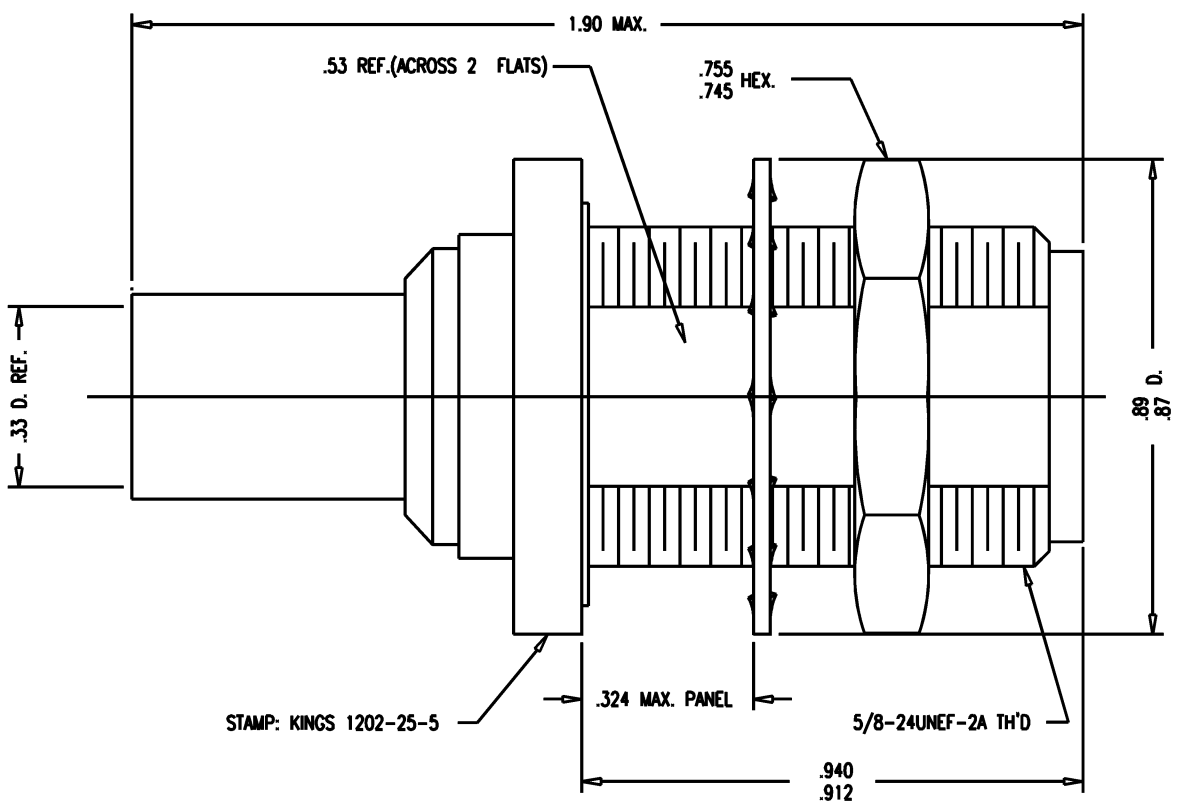

- NOTES:
- FOR USE WITH MC DONNELL DOUGLAS ST5M1398-001, -002 & -003 CABLES.
 - FOR CABLING INSTRUCTIONS SEE 3-597.
 - FOR CRIMPING USE DIE KTH-2005.
 - INTERFACE PER MIL-STD-348, FIG. 304-2.
 - MARK PACKAGE: KINGS 1202-25-5
MDAE 5M1985-001
 - MATERIALS:
INSULATOR-TEFLON, ASTM-D-4894
LOCKWASHER-PHOS. BRONZE, ASTM-B-103
CENTER CONTACT-BER. COP., ASTM-B-196
K-GRIP SLEEVE-COM. BRONZE, ASTM-B-140
GASKET-SILICONE RUBBER, ZZ-R-765
ALL OTHER METAL PARTS-BRASS, ASTM-B16
 - FINISHES:
CENTER CONTACT-GOLD PLATE PER MIL-G-45204
ALL OTHER METAL PARTS-SILVER PLATE PER QQ-S-365
 - ELECTRICAL CHARACTERISTICS:
NOMINAL IMPEDANCE-50 OHMS
FREQUENCY RANGE-DC TO 11 GHZ
WORKING VOLTAGE-1000 VRMS

GSD

1202-25-5

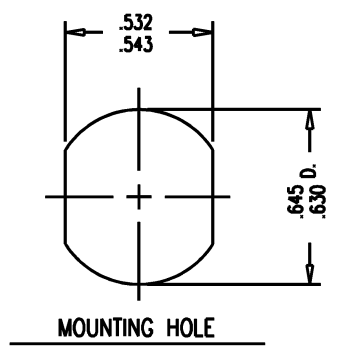

GSD

REVISIONS	
ISSUE	CHANGES
0	ER 35588 KH 02/06/95
1	CN 38898 A DCT 7/31/93

SCALE	4:1		
APPROX SURFACE AREA			
USED ON			
REF:	MC AIR 5M1985-001 REV. B		
JACK, BULKHEAD, N			
DRAWN	KH	DATE	02/06/95
DESIGN	LI	DATE	02/07/95
APPR.		DATE	
KINGS ELECTRONICS CO., INC. ROCK HILL, SOUTH CAROLINA 29730			
1202-25-5			