

## Wall Industries, Inc.

---

### DCHF500 SERIES

---

**2:1 & 4:1 Input Voltage Ranges**  
**12 & 24 VDC Single Outputs**  
**480~504W Output Power**  
**DC/DC Chassis Mount Power Converters**

---



---

#### FEATURES

- RoHS Compliant
- $\pm 10\%$  Voltage Adjustment Range
- 2:1 & 4:1 Input Voltage Ranges
- Built-in Fan
- Built-in Remote Sense (Option)
- Remote ON/OFF Control (Option)
- 480~504W Output Power
- 12VDC and 24VDC Single Outputs Voltages
- 100% Full Load Burn-in Tested
- Dimensions: 8.46 x 4.53 x 1.97 Inches
- Short Circuit, Over Voltage, Over Load, and Over Temperature Protected

---

#### DESCRIPTION

The DCHF500 series of DC/DC power converters offers up to 504W output power in an 8.46 x 4.53 x 1.97 enclosed case. This series has 12VDC and 24VDC single output models with either a 2:1 input voltage range of 72-144VDC or a 4:1 input voltage range of 19-72VDC. Some features include  $\pm 10\%$  output adjustability, remote sense (optional), remote ON/OFF control (optional), and a built-in fan. These supplies are RoHS compliant and are protected against short circuit, over voltage, over load, and over temperature conditions. All supplies in this series are 100% full load burn-in tested.

<b>SPECIFICATIONS: DCHF500 Series</b>					
<p>All specifications are based on 25°C, Nominal Input Voltage, and Maximum Output Current unless otherwise noted. We reserve the right to change specifications based on technological advances.</p>					
<b>SPECIFICATION</b>	<b>TEST CONDITIONS</b>	<b>Min</b>	<b>Nom</b>	<b>Max</b>	<b>Unit</b>
<b>INPUT SPECIFICATIONS</b>					
Input Voltage Range	48VDC nominal input models	19	48	72	VDC
	110VDC nominal input models	72	110	144	
Remote ON/OFF Control		optional			
<b>OUTPUT SPECIFICATIONS</b>					
Output Voltage		See Table			
Output Voltage Adjustment Range		-10		+10	%
Line Regulation	Full load	≤ -0.5		≤ +0.5	%
Load Regulation		≤ -0.5		≤ +0.5	%
Output Current		See Table			
Output Power		See Table			
Ripple & Noise			150		mVp-p
Remote Sense		optional			
<b>PROTECTION</b>					
Over Voltage Protection		115		150	% Vo
Over Load Protection		110		130	% Io
Short Circuit Protection		Yes			
Over Temperature Protection		Yes			
<b>GENERAL SPECIFICATIONS</b>					
Efficiency		See Table			
Withstand Voltage	Input to Output	All for 1 minute	1000		VDC
	Input to FG		1000		
	Output to FG		500		
Isolation Resistance	At 500VDC	> 100			MΩ
<b>ENVIRONMENTAL SPECIFICATIONS</b>					
Operating Temperature		-10		+50	°C
Storage Temperature		-20		+85	°C
Cooling Method		fan			
<b>PHYSICAL SPECIFICATIONS</b>					
Dimensions (L x W x H)		8.46 x 4.53 x 1.97 inches (215 x 115 x 50 mm)			
Weight		2.4 lbs (1100g)			
<b>SAFETY &amp; EMC CHARACTERISTICS</b>					
Safety Standards		Design refer to LVD			
EMC Standards		Design refer to EN55022, EN61000-4			

MODEL SELECTION TABLE						
Model Number	Input Voltage	Output Voltage	Output Current	Ripple & Noise	Output Power	Efficiency
DCHF500W-SMD48-12	48 VDC (19 - 72 VDC)	12 VDC	40.0 A	150mVp-p	480W	86%
DCHF500W-SMD48-24		24 VDC	21.0 A	150mVp-p	504W	88%
DCHF500W-SMD110-12	110 VDC (72 - 144 VDC)	12 VDC	40.0 A	150mVp-p	480W	87%
DCHF500W-SMD110-24		24 VDC	21.0 A	150mVp-p	504W	89%

**MECHANICAL DRAWING**

Unit: inches (mm)

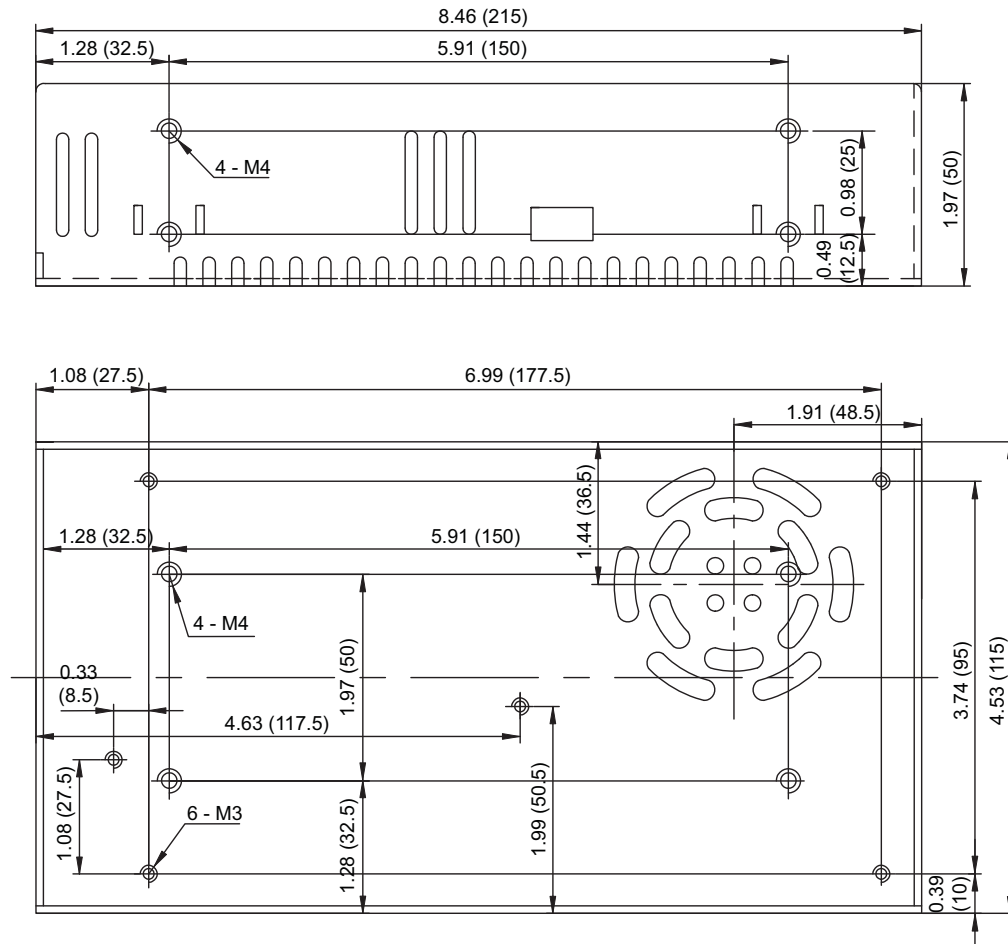

**PIN CONNECTIONS**

Unit: inches (mm)

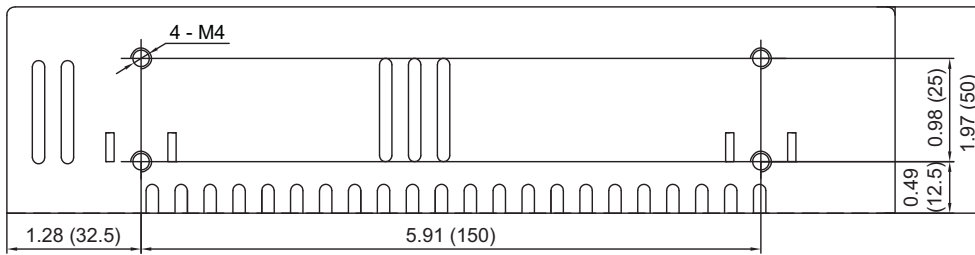
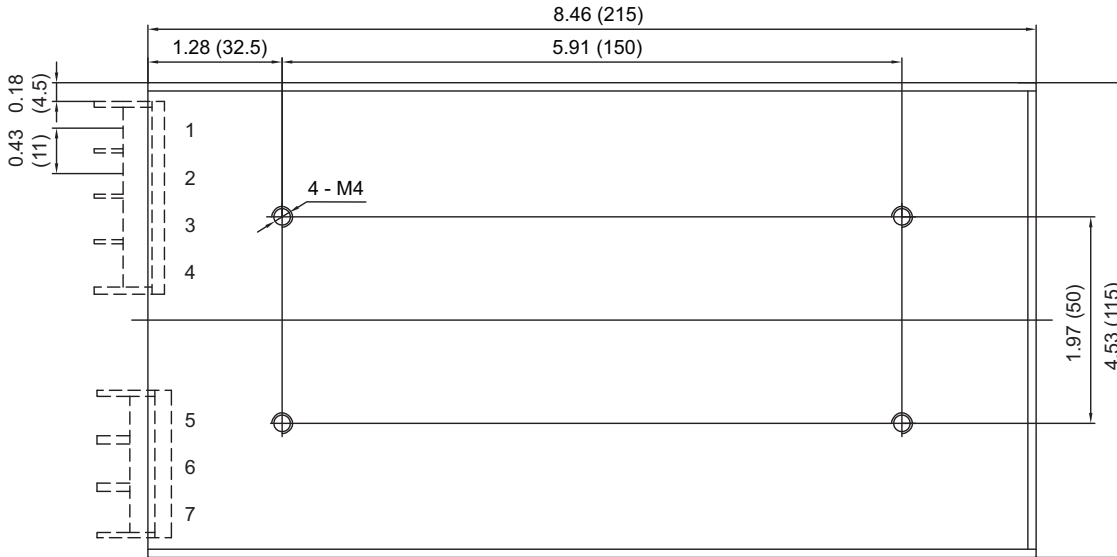

PIN CONNECTIONS	
Pin No	Assignment
1, 2	DC Output (V+)
3, 4	DC Output (V-)
5	FG
6	DC Input (V+)
7	DC Input (V-)
Screw Size: M4*6	

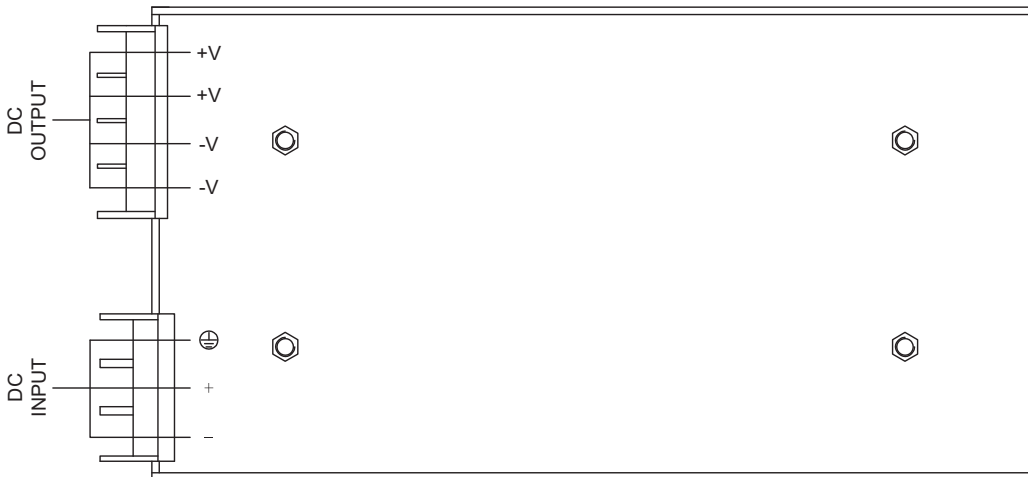

## COMPANY INFORMATION

Wall Industries, Inc. has created custom and modified units for over 50 years. Our in-house research and development engineers will provide a solution that exceeds your performance requirements on-time and on budget. Our ISO9001-2008 certification is just one example of our commitment to producing a high quality, well-documented product for our customers.

Our past projects demonstrate our commitment to you, our customer. Wall Industries, Inc. has a reputation for working closely with its customers to ensure each solution meets or exceeds form, fit and function requirements. We will continue to provide ongoing support for your project above and beyond the design and production phases. Give us a call today to discuss your future projects.

Contact **Wall Industries** for further information:

<u>Phone:</u>	☎(603)778-2300
<u>Toll Free:</u>	☎(888)597-9255
<u>Fax:</u>	☎(603)778-9797
<u>E-mail:</u>	<a href="mailto:sales@wallindustries.com">sales@wallindustries.com</a>
<u>Web:</u>	<a href="http://www.wallindustries.com">www.wallindustries.com</a>
<u>Address:</u>	5 Watson Brook Rd. Exeter, NH 03833