

# C4800 Series

## 2400-5000 AC/DC-DC/DC-BATTERY CHARGERS SINGLE OUTPUT

### FEATURES

- DC input 10 - 800 V
- AC input 1 or 3-phase, 47 - 400 Hz
- DC output 12-400V
- Continuous short circuit protection
- Overvoltage protection with auto restart
- Thermal shutdown with auto restart
- Industrial grade components
- Compact and robust design



### DC/DC CONVERTERS

2400 W		3500 W				5000 W					OUTPUT VDC			
10-16 VDC	OUTPUT AMPS	20-32 VDC	OUTPUT AMPS	40-64 VDC	50-80 VDC	OUTPUT AMPS	80-160 VDC	160-320 VDC	320-380 VDC	320-640 VDC	450-800 VDC	OUTPUT AMPS	ADJ.	RANGE
C 4802	136	C 4822	190	C 4832	C 4842	240	C 4852	C 4872	C 4882 Z	C 4872 G	C 4872 K	260	12	11 - 13
C 4803	116	C 4823	160	C 4833	C 4843	200	C 4853	C 4873	C 4883 Z	C 4873 G	C 4873 K	220	15	14 - 16
C 4804	92	C 4824	120	C 4834	C 4844	150	C 4854	C 4874	C 4884 Z	C 4874 G	C 4874 K	160	24	23 - 26
C 4805	80	C 4825	100	C 4835	C 4845	130	C 4855	C 4875	C 4885 Z	C 4875 G	C 4875 K	140	28	26 - 30
C 4809	44	C 4829	60	C 4839	C 4849	76	C 4859	C 4879	C 4889 Z	C 4879 G	C 4879 K	80	48	45 - 55
C 4806	36	C 4826	50	C 4836	C 4846	62	C 4856	C 4876	C 4886 Z	C 4876 G	C 4876 K	66	60	58 - 68
C 4807	20	C 4827	26	C 4837	C 4847	36	C 4857	C 4877	C 4887 Z	C 4877 G	C 4877 K	40	110	100 - 130
C 4807 J	12	C 4827 J	14	C 4837 J	C 4847 J	20	C 4857 J	C 4877 J	C 4887 ZJ	C 4877 GJ	C 4877 KJ	20	200	190 - 200
C 4808	10	C 4828	14	C 4838	C 4848	20	C 4858	C 4878	C 4888 Z	C 4878 G	C 4878 K	20	220	200 - 250
C 4808 J	6	C 4828 J	7	C 4838 J	C 4848 J	10	C 4858 J	C 4878 J	C 4888 ZJ	C 4878 GJ	C 4878 KJ	10	400	380 - 400

### AC/DC POWER SUPPLIES

4 KW		5 KW					OUTPUT VDC		
INPUT VAC, 1-PHASE		INPUT VAC, 3-PHASE					OUTPUT AMPS	ADJ.	RANGE
115 ± 20%	OUTPUT AMPS	230 + 15% - 20%	3X200 + 15% - 20%	3X400 + 15% - 20%	3X480 + 15% - 20%	OUTPUT AMPS	ADJ.	RANGE	
C 4862	260 <sup>3)</sup>	C 4882	C 4862 V	C 4882 V	C 4892 V	260	12	11 - 13	
C 4864	220 <sup>3)</sup>	C 4883	C 4863 V	C 4883 V	C 4893 V	220	15	14 - 16	
C 4865	150	C 4884	C 4864 V	C 4884 V	C 4894 V	160	24	23 - 26	
C 4869	130	C 4885	C 4865 V	C 4885 V	C 4895 V	140	28	26 - 30	
C 4866	72	C 4889	C 4866 V	C 4889 V	C 4899 V	80	48	45 - 55	
C 4867	60	C 4886	C 4866 V	C 4886 V	C 4896 V	66	60	58 - 68	
C 4867 J	30	C 4887	C 4867 V	C 4887 V	C 4897 V	40	110	100 - 130	
C 4868	16	C 4887 J	C 4867 VJ	C 4887 VJ	C 4897 VJ	20	200	190 - 200	
C 4868 J	16	C 4888	C 4868 V	C 4888 V	C 4898 V	20	220	200 - 250	

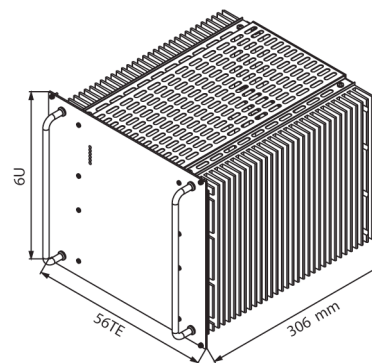

Eurocassette / approx. 16.0 kg  
(pluggable module for 19" sub-rack)

### BATTERY CHARGERS

4 KW		5 KW					OUTPUT VDC		
INPUT VAC, 1-PHASE		INPUT VAC, 3-PHASE					OUTPUT AMPS	ADJ.	RANGE
115 ± 20%	OUTPUT AMPS	230 + 15% - 20%	3X200 + 15% - 20%	3X400 + 15% - 20%	3X480 + 15% - 20%	OUTPUT AMPS	ADJ.	RANGE	
B 4861	220 <sup>3)</sup>	B 4881	B 4861 V	B 4881 V	B 4891 V	220	12	12 - 16	
B 4862	122	B 4882	B 4862 V	B 4882 V	B 4892 V	140	24	24 - 32	
B 4864	62	B 4884	B 4864 V	B 4884 V	B 4894 V	70	48	48 - 64	
B 4866	50	B 4886	B 4866 V	B 4886 V	B 4896 V	60	60	60 - 80	
B 4867	28	B 4887	B 4867 V	B 4887 V	B 4897 V	34	110	110 - 145	
B 4868	14	B 4888	B 4868 V	B 4888 V	B 4898 V	18	220	220 - 290	

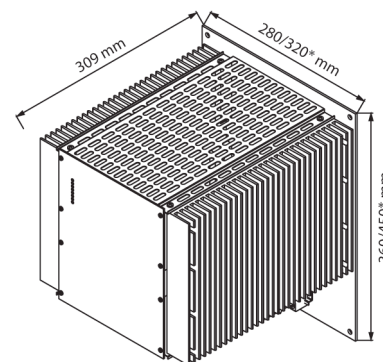

Wall mount / approx. 19.0 kg  
(\*) applicable to models >= 150 A input or output current

# Euro Series

## EURO OPTION SPECIFICATIONS

### OPTIONS INPUT

Option “i” (inrush current limiting): A thermistor is connected in series with the input lines which changes its resistance from high to low when it gets hot. It does not reduce the current surge if the input power is interrupted for a short period of time not allowing the thermistor to cool down. Thermistors are fitted as standard to all mains input models except for 1-phase input of models > 2.5kW. Thermistors are available up to 45A. For higher input current an electronic inrush current limitation can be offered.

Option “ie” electronic inrush current limiting An electronic circuit limits the inrush current.

Option “sd” (series diode): A series diode protects the module against input voltage of wrong polarity (additional power losses).

Option “ad” (anti-parallel diode): To avoid the power losses of a series diode a diode is provided with opposite polarity in parallel to the input blowing an internal or external fuse if the module is connected to a supply with wrong polarity.

Option “au” (auto-ranging) For standard dual AC input models the range of 115/230Vac is to be selected by connecting the input line to different pins on the connector. With auto-ranging the unit senses the input voltage and provides automatically the correct connection.

Option “p” (power fail): A signal (logic or relay) is given if the input voltage (AC or DC) drops below the specified limit. In AC input units we sense the rectified input voltage so that a power fail alarm will not be triggered if at light loads mains power returns before the input capacitors are substantially discharged.

Option “r” (relay): A relay instead of a logic signal is provided for failure indication.

### OUTPUT

Option “dd” (decoupling diode): For redundant operation the outputs of two or more units are paralleled behind de-coupling diodes so that an internal fault of one module does not affect the operation of the others. These diodes cause power losses.

Option “cs” (active current sharing): An additional control circuit provides active current sharing via an interconnecting wire between converters that operate in parallel. Active current sharing should be used for multi-output units operating in parallel.

Option “csi” (current sharing interrupt): Option “csi” will effect the removal of the “cs” signal. Should there be an instance where a unit is not supplying the load, then the effect of its “cs” signal is removed, and the load voltage is unaffected by this condition.

Option “h1” (inhibit): A terminal connected to the negative input line also shuts off the converter. This can also be used in conjunction with a thermal trip which shuts the unit down.

Option “h2” (inhibit): Operation of the unit is inhibited if a voltage signal (5V/10mA) is applied in reference to the negative line of the (main) output.

Option “rco” (reducing current limiting at over temperature) A circuit reduces the current limiting level at higher temperature (to be specified).

Option “d” (DC-ok, one output): A logic signal is given if the output voltage (main output in multi-output systems) is below the specified limit.

Option “m” (DC-ok, all outputs): In multi-output systems a logic signal is provided if the voltage of any output is below the specified limit.

Option “ac” (AC ok) A logic signal connected to relay contacts is given if the output voltage of an inverter is below the specified limit.

Option “y” (sys-reset): This logic signal is a combination of power fail and DC-ok as specified for VME systems.

Option “r” (relay): A relay instead of a logic signal is provided for failure indication.

### PROGRAMMING & MONITORING

PROGRAMMING SERIES 200-5800, 6600		
	By external signal, 0-10Vdc	<b>eu1</b>
Of output voltage from 0 to 100%	By external signal, 4-20mA	<b>eu2</b>
	By 270° potentiometer	<b>eu3</b>
	By 10 turn potentiometer	<b>eu4</b>
	By external signal, 0-10Vdc	<b>ei1</b>
Of output current from 0 to 100%	By external signal, 4-20mA	<b>ei2</b>
	By 270° potentiometer	<b>ei3</b>
	By 10 turn potentiometer	<b>ei4</b>
Isolating amplifier for programming		<b>iso</b>
Programming via interface RS232 or IEEE488		

MONITORING SERIES 200-5800, 6600		
Of output voltage from 0 to 100%	By external signal, 0-10Vdc	<b>mu1</b>
	By external signal, 4-20mA	<b>mu2</b>
Of output current from 0 to 100%	By external signal, 0-10Vdc	<b>mi1</b>
	By external signal, 4-20mA	<b>mi2</b>
Isolating amplifier for programming		<b>iso</b>
Programming via interface RS232 or IEEE488		

CHARGER PROGRAMMING (ALL SERIES)		
Temperature compensated charging voltage(sensor not included)		<b>tc</b>
Temperature sensor	Not interchangeable due to fixed resistor values	<b>ts1</b>
	Interchangeable, IC controlled	<b>ts2</b>
Automatic selection of charging characteristic (float / equalize charge) with timer		<b>ch1</b>
Additionally: Manual selection of charging characteristic		<b>ch2</b>
Additionally: Boost charge operation (manually activated with time delayed return to normal operation)		<b>ch3</b>

# Euro Series

## EURO OPTION SPECIFICATIONS

PROGRAMMING / MONITORING- SERIES 6400		
Programming of output voltage and current from 0-100% including isolation	By external signal, 0-10Vdc	<b>e1</b>
	By external signal, 4-20mA	<b>e2</b>
Programming of output voltage from 0-100%	By 270° potentiometer	<b>eu3</b>
	By 10 turn potentiometer	<b>eu4</b>
Programming of output current from 0-100%	By 270° potentiometer	<b>ei3</b>
	By 10 turn potentiometer	<b>ei4</b>
Monitoring of output voltage and current from 0-100% including isolation	By external signal, 0-10Vdc	<b>m1</b>
	By external signal, 4-20mA	<b>m2</b>
Remote on/off programming and monitoring of output voltage and current from 0-100% including isolation	By external signal, 0-10Vdc	<b>em1</b>
	By external signal, 4-20mA	<b>em2</b>
	Via RS232 and IEEE488	<b>em3</b>
Improved tolerance	Between reference (external signal) and measured value / between measured value and displayed signal: voltage 0.2% and current 0.5%.	<b>tol</b>

### ENVIRONMENT

Option “**t**” (tropical protection):The unit is given additional protection by a heavy coat of varnish on the printed circuit board(s) and components.

Option “**c**” (extended temperature range):The circuit is designed and tested for operation at an ambient temperature as low as -40 °C.

Option “**ms**” (increased mechanical strength): Screws are secured by Locktite and heavy components are fastened by ties and/or glue. Modules with the “ms” option meet the standard EN61373 regarding shock and vibration.

### MECHANICS

Standard mounting “**Eurocassette**” pluggable module for 19” sub-racks 84TE

Option “**w**” (wall mounting): Module is screwed against a mounting plate for installation in a cabinet. The load connections are typically a terminal block.

Option “**cha**” (chassis mount) Module is designed for installation to a structure or within cabinet. Screw type connectors are supplied with the module.

Option “**din**” (DIN rail mount) Module is designed for DIN rail mounting to a structure or within Cabinet. Screw type connectors are supplied with the module.