

## General Description

The EC8812 series of fixed output ultra low dropout linear regulators are designed for portable battery powered applications, which require low power consumption and low dropout voltage. Each device contains a bandgap voltage reference, an error amplifier, a PMOS power transistor, and current limit and temperature limit protection circuits.

The EC8812 is designed to work with low cost electrolytic and ceramic capacitors and requires a minimum output capacitor of 10 $\mu$ F.

## Features

- Typical 150mV Dropout Voltage at 500mA.
- Output Voltages: 0.8V to 3.9V (0.1V Step)
- Excellent Line and Load Regulation.
- High Accuracy Output Voltage of 2%.
- Ultra-Low Ground Current at 150 $\mu$ A (Typ.)
- Thermal and Over-Current Protection.
- Short Circuit Protection
- Standard SOT-223 and TO-252 Package.

## Applications

- USB removable devices
- MPEG4 devices
- Wireless LAN's
- Hand-Held Instrumentation.
- Portable DVD players
- Digital camera

## Typical Application

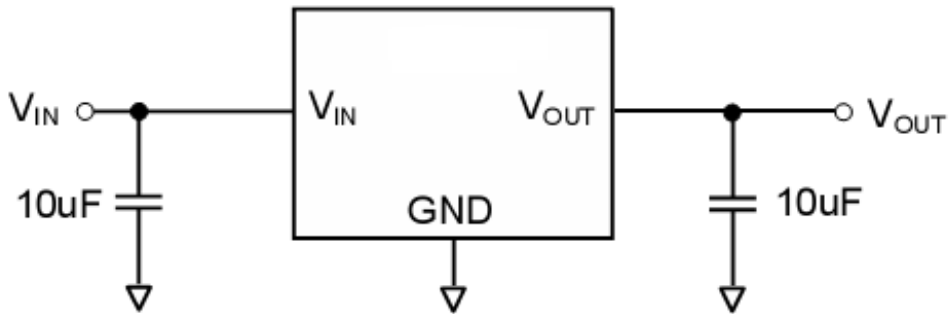

## Pin Configurations

**SOT-223 (Top View)**

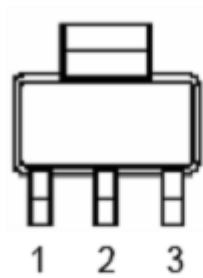

**Pin Type A :** 1:IN, 2:GND, 3:OUT

**SOT -223 (Top View)**

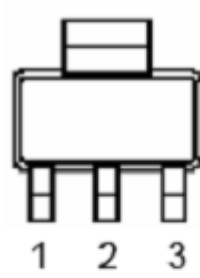

**Pin Type B :** 1:GND, 2:OUT, 3:IN

**TO-252 (Top View)**

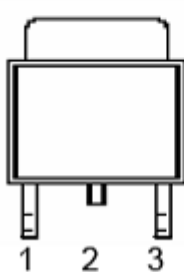

**Pin type T :** 1:GND, 2:OUT, 3:IN

**TO-252 (Top View)**

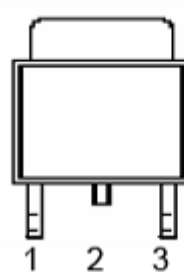

**Pin Type G :** 1:IN, 2:GND, 3:OUT

## Pin Description

Pin Name	Pin Function Description
GND	Ground
OUT	Output Voltage
IN	Input Voltage

## Functional Block Diagram

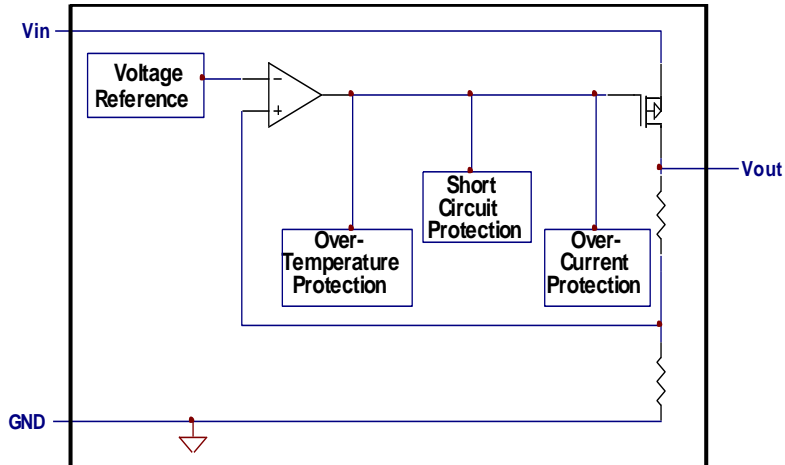

## Ordering Information

### 1. SOT223 Package

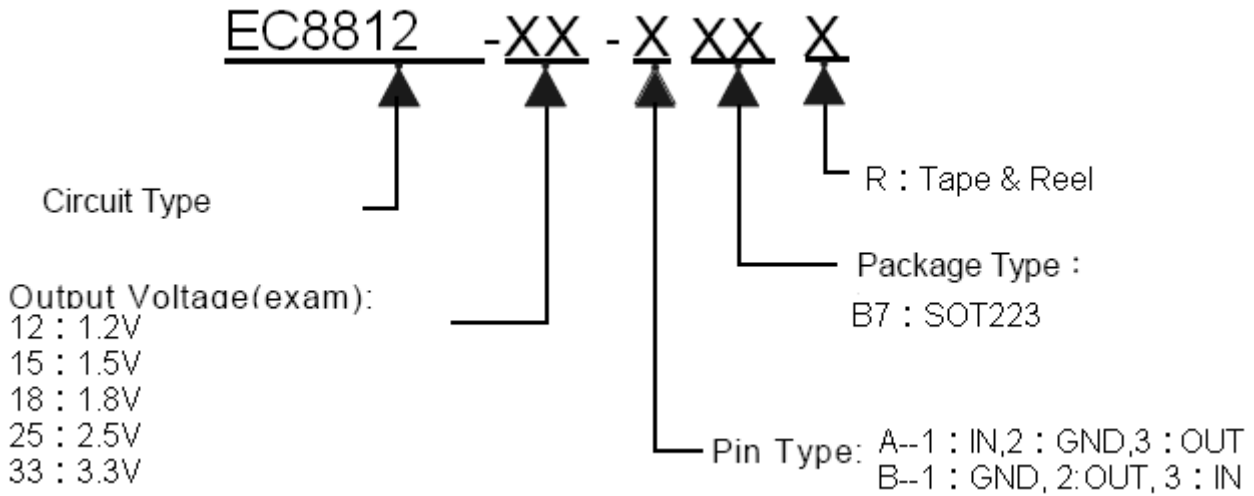

### 2. TO252-3L Package

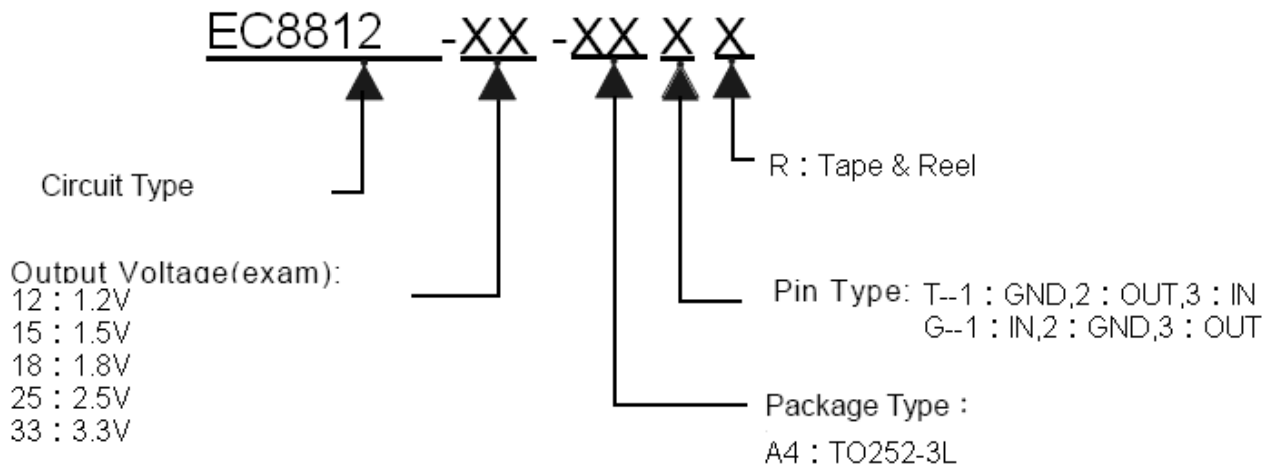

**Marking Information :****1. SOT223 :**

Device	Marking Information	Package Type (Pin Type)	Remarks
EC8812NNAB7R	12NNA LLLLLL	SOT223 (Pin Type : A Type)	NN is Output Voltage(Ex : 33=3.3V) LLLLLL : Date Code
EC8812NNBB7R	12NNB LLLLLL	SOT223 (Pin Type : A Type)	NN is Output Voltage(Ex : 33=3.3V) LLLLLL : Date Code

**2. TO252-3L :**

Device	Marking Information	Package Type (Pin Type)	Remarks
EC881212A4TR	8812 12TYW	TO252-3L (T Type)	1. Y : Year code(D=2013;E=2014; F=2015...) 2. W : Week Code(The big character of A~Z is for the week of 1~26, and small a~z is for the week of 27~52.)
EC881215A4TR	8812 15TYW		
EC881218A4TR	8812 18TYW		
EC881225A4TR	8812 25TYW		
EC881233A4TR	8812 33TYW		
EC881212A4GR	8812 12GYW	TO252-3L (G Type)	
EC881215A4GR	8812 15GYW		
EC881218A4GR	8812 18GYW		
EC881225A4GR	8812 25GYW		
EC881233A4GR	8812 33GYW		

**Absolute Maximum Ratings**

Parameter	Symbol	Value	Units
Input Voltage	$V_{IN}$	6	V
Output Voltage Range	$V_{OUT}$	-0.3 to $V_{IN}$	V
Power Dissipation	$P_D$	Internally Limited <sup>(3)</sup>	
Output Short Circuit Duration		Infinite	
Thermal Resistance, Junction-to-Ambient	$\Theta_{JA}$	155(SOT-223)	°C/W
		90(TO-252)	
Lead Temperature (Soldering, 5 sec.)		260	°C
Junction Temperature Range	$T_J$	-40 to +150	°C
Storage Temperature Range	$T_S$	-40 to +150	°C

**Recommended Operating Conditions**

Parameter	Symbol	Value	Units
Supply Input Voltage Range	$V_{IN}$	5	V
Junction Temperature Range	$T_J$	-40 to +125	°C



## Electrical Characteristics

( $V_{IN} = 5V$ ;  $C_{IN} = 10\mu F$ ;  $C_{OUT} = 10\mu F$ ;  $I_{OUT} = 10mA$ ;  $T_J = 25^\circ C$ ; unless otherwise noted)

Symbol	Parameter	Test Conditions	Min	Typ	Max	Unit
$V_{OUT}$	Output Voltage Accuracy	$V_{out}=1.2V$	1.176	1.2	1.224	V
		$V_{out}=1.5V$	1.47	1.5	1.53	
		$V_{out}=1.8V$	1.764	1.8	1.836	
		$V_{out}=2.5V$	2.45	2.5	2.55	
		$V_{out}=3.3V$	3.234	3.3	3.366	
$\Delta V_{OUT}/V_{OUT}$	Line Regulation	$V_{IN} = (V_{OUT} + 0.7)V$ to 5.5V	--	0.1	--	%/V
$\Delta V_{OUT}/V_{OUT}$	Load Regulation <sup>(5)</sup>	$V_{IN} = (V_{OUT} + 0.7)V$ $I_{OUT} = 10mA$ to 1500mA	--	2	--	%
$\Delta V_{OUT}/\Delta T$	Output Voltage Temperature Coefficient	Note 4	--	0.1	--	mV/ $^\circ C$
$V_{IN} - V_{OUT}$	Dropout Voltage <sup>(6)</sup>	$I_{OUT} = 150mA$	--	40	--	mV
		$I_{OUT} = 500mA$	--	150	--	mV
		$I_{OUT} = 1000mA$	--	300	--	mV
$T_{PROTECTION}$	Thermal Protection	Thermal Protection Temperature	--	150	--	$^\circ C$
		Protection Hysterisys	--	30	--	$^\circ C$
$I_Q$	Quiescent Current	$I_{OUT} = 0mA$	--	150	--	$\mu A$
$I_{LIMIT}$	Current Limit		--	2.5	--	A
$I_{short}$	Short Circuit Current	$V_{in}=V_{out}+1V$ ; $V_{out}< 0.4V$	--	0.55	--	A

**Note 1:** Exceeding the absolute maximum rating may damage the device.

**Note 2:** The device is not guaranteed to function outside its operating rating.

**Note 3:** The maximum allowable power dissipation at any  $T_A$  (ambient temperature) is calculated using:  $P_{D(MAX)} = (T_{J(MAX)} - T_A)/\theta_{JA}$ . Exceeding the maximum allowable power dissipation will result in excessive die temperature, and the regulator will go into thermal shutdown. See "Thermal Consideration" section for details

**Note 4:** Output voltage temperature coefficient is the worst case voltage change divided by the total temperature range.

**Note 5:** Regulation is measured at constant junction temperature using low duty cycle pulse testing. Parts are tested for load regulation in the load range from 0.1mA to 1200mA. Changes in output voltage due to heating effects are covered by the thermal regulation specification.

**Note 6:** Dropout voltage is defined as the input to output differential at which the output voltage drops 2% below its nominal value measured at 1V differential.



## Typical Performance Characteristics

Reference Voltage vs. Temperature

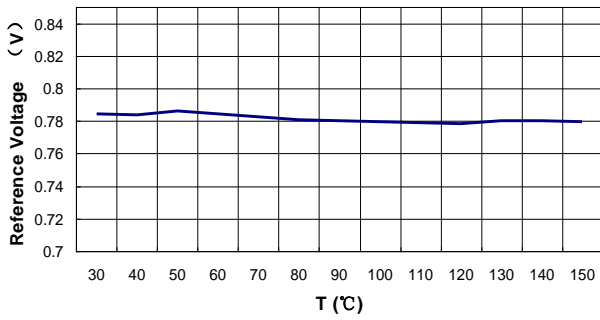

Output Voltage vs. Load Current

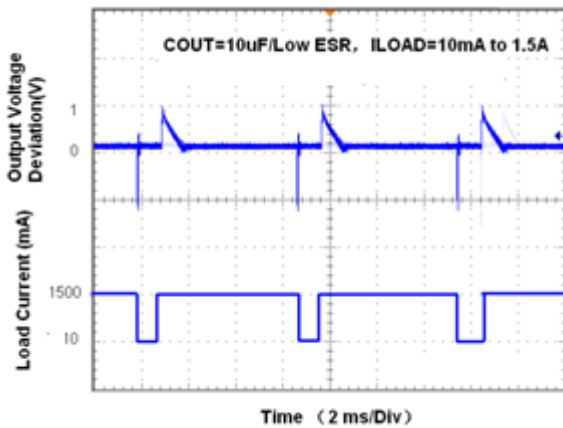
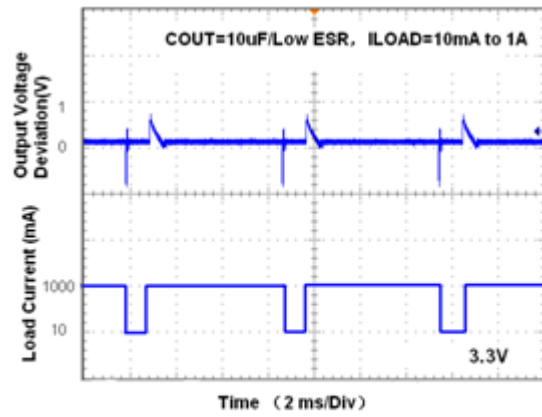
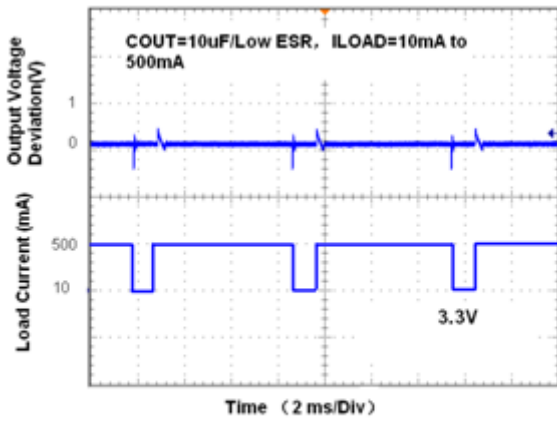
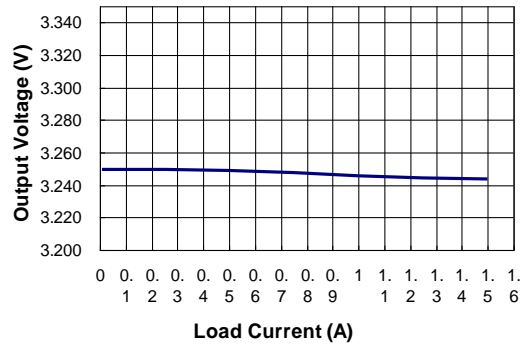

Output Voltage vs. Input Voltage

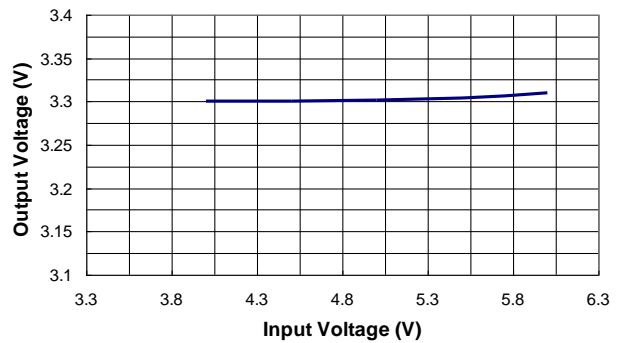

---

## Applications Information

### Application Hints

Like any low dropout regulator, EC8812 requires external capacitors to ensure stability. The external capacitors must be carefully selected to ensure performance.

### Input Capacitor

An input capacitor of at least 10 $\mu$ F is required. Ceramic or Tantalum can be used. The value can be increased without upper limit.

### Output Capacitor

An output capacitor is required for stability. It must be placed no more than 1 cm away from the V<sub>OUT</sub> pin, and connected directly between V<sub>OUT</sub> and GND pins. The minimum value is 10 $\mu$ F but may be increased without limit.

### Thermal Considerations

It is important that the thermal limit of the package is not exceeded. The EC8812 has built-in thermal protection. When the thermal limit is exceeded, the IC will enter protection, and V<sub>OUT</sub> will be pulled to ground. The power dissipation for a given application can be calculated as following:

The power dissipation (P<sub>D</sub>) is

$$P_D = I_{OUT} * [V_{IN} - V_{OUT}]$$

The thermal limit of the package is then limited to  $P_{D(MAX)} = [T_J - T_A]/\Theta_{JA}$  where T<sub>J</sub> is the junction temperature, T<sub>A</sub> is the ambient temperature, and  $\Theta_{JA}$  is around 155°C/W (SOT-223) for EC8812. The EC8812 is designed to enter thermal protection at 170°C. For example, if T<sub>A</sub> is 25°C then the maximum P<sub>D</sub> is limited to about 0.94W. In other words, if I<sub>OUT(MAX)</sub> = 1200mA, then [V<sub>IN</sub> - V<sub>OUT</sub>] cannot exceed 780mV.

## Outline Drawing For SOT-223

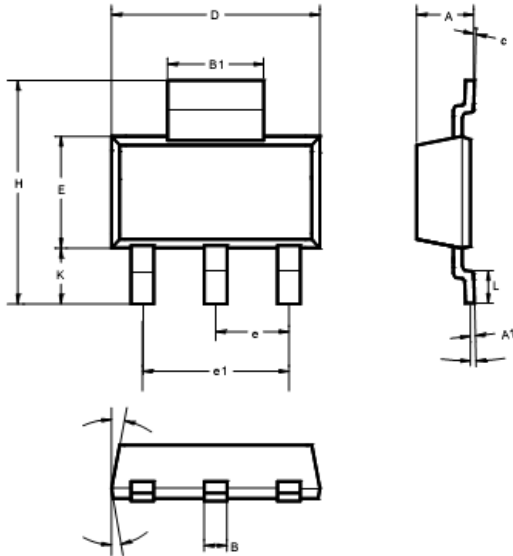

	MILLIMETERS		
	MIN	TYP	MAX
A	1.50	1.65	1.80
A1	0.02	0.05	0.08
B	0.60	0.70	0.80
B1	2.90	-	3.15
c	0.28	0.30	0.32
D	6.30	6.50	6.70
E	3.30	3.50	3.70
e	2.3 BSC		
e1	4.6 BSC		
H	6.70	7.00	7.30
L	0.91	1.00	1.10
K	1.50	1.75	2.00
$\alpha$	0°	5°	10°
$\beta$		3°	

## Outline Drawing For TO252-3L

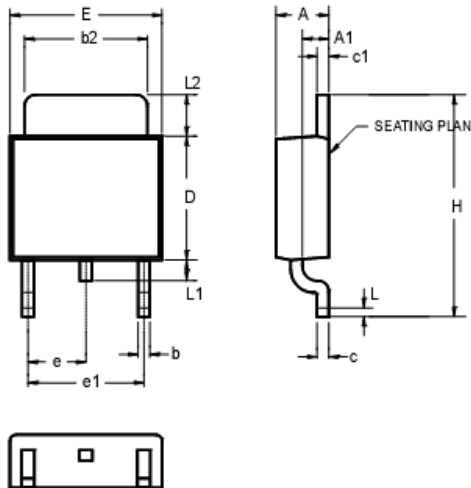

	INCHES			MILLIMETERS		
	MIN	TYP	MAX	MIN	TYP	MAX
A	0.086	-	0.094	2.18	-	2.39
A1	0.040	-	0.050	1.02	-	1.27
b	-	0.024	-	-	0.61	-
b2	0.205	-	0.215	5.21	-	5.46
c	0.018	-	0.023	0.46	-	0.58
c1	0.018	-	0.023	0.46	-	0.58
D	0.210	-	0.220	5.33	-	5.59
E	0.250	-	0.265	6.35	-	6.73
e	0.090 BSC			2.29 BSC		
e1	0.180 BSC			4.58 BSC		
H	0.370	-	0.410	9.40	-	10.41
L	0.020	-	-	0.51	-	-
L1	0.025	-	0.040	0.64	-	1.02
L2	0.060	-	0.080	1.52	-	2.03