

HF3000C-XZ Series (RoHS Compliant)

3-phase 3-line 500VAC

Small footprint & Compact



UL1283 (file No.E102708)
EN60939-2 (file No.R50031226)

Applications

IGBT Inverter, AC Servo, NC Machinery

Specifications

Part No.	Rated Current	Weight	Dimensions [mm]												
			A	B	C	D	E	F	G	H	J	K	L		M
HF3010C-XZ	10A	1.5Kg	270	258	243	228	110	85	32	50	26	M4	M4	5.5x7	fig1
HF3030C-XZ	30A	2.0Kg	270	258	243	228	110	85	32	50	26	M4	M4	5.5x7	
HF3050C-XZ	50A	4.5Kg	390	370	320	160	135	44	40	70	M6	M6	6.5x8	fig2	
HF3100C-XZ	100A	8.5Kg	480	450	410	170	135	57	45	80	M8	M8	6.5x8		
HF3150C-XZ	150A	13Kg	510	490	440	190	160	57	55	90	M8	M8	6.5x8		
HF3200C-XZ	200A	20Kg	620	590	520	200	160	12	93	140	M10	M10	6.5x8	fig3	
HF3250C-XZ	250A	20Kg	620	590	520	200	160	12	93	140	M10	M10	6.5x8		
HF3300C-XZ	300A	20Kg	620	590	520	200	160	12	93	140	M10	M10	6.5x8		
Rated Voltage	500VAC														
Leakage Current	5.0mA														
Ambient temp.	-20 up to 50 Deg.C														

fig.1 (10, 30,A)

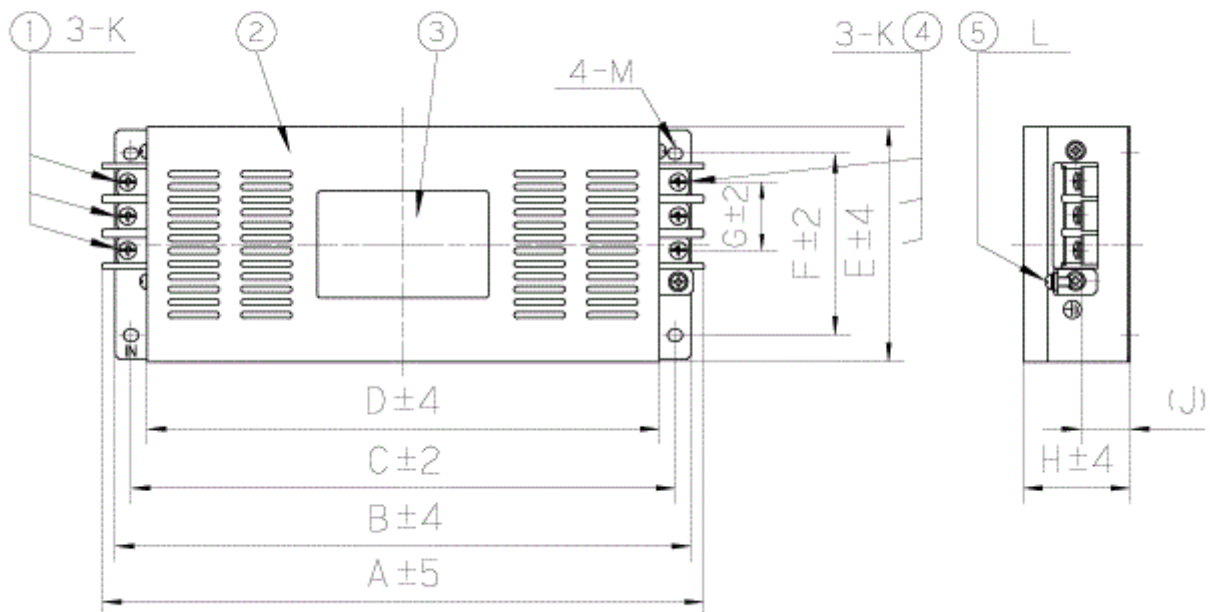

fig.2 (50, 100, 150A)

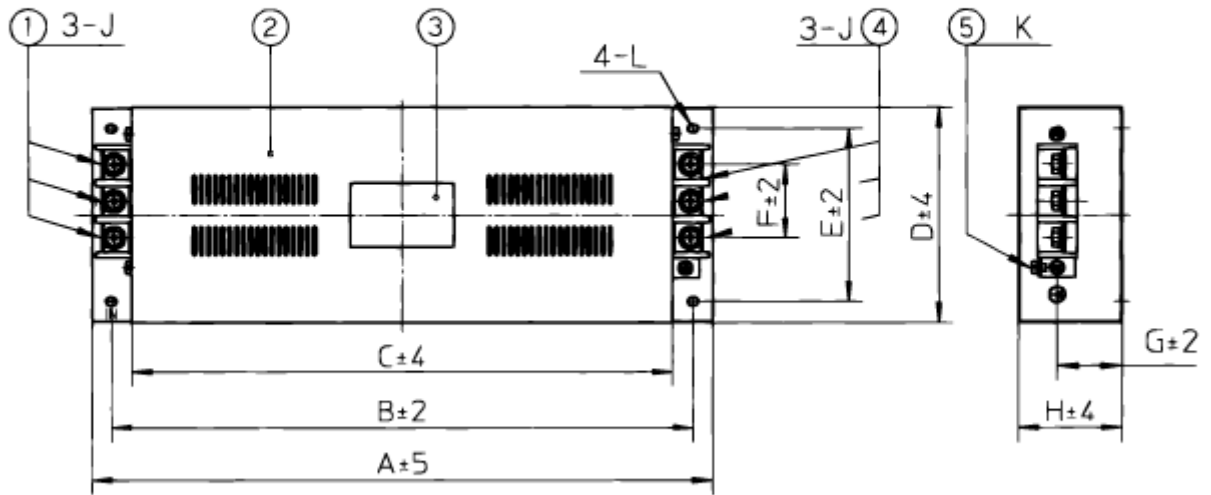
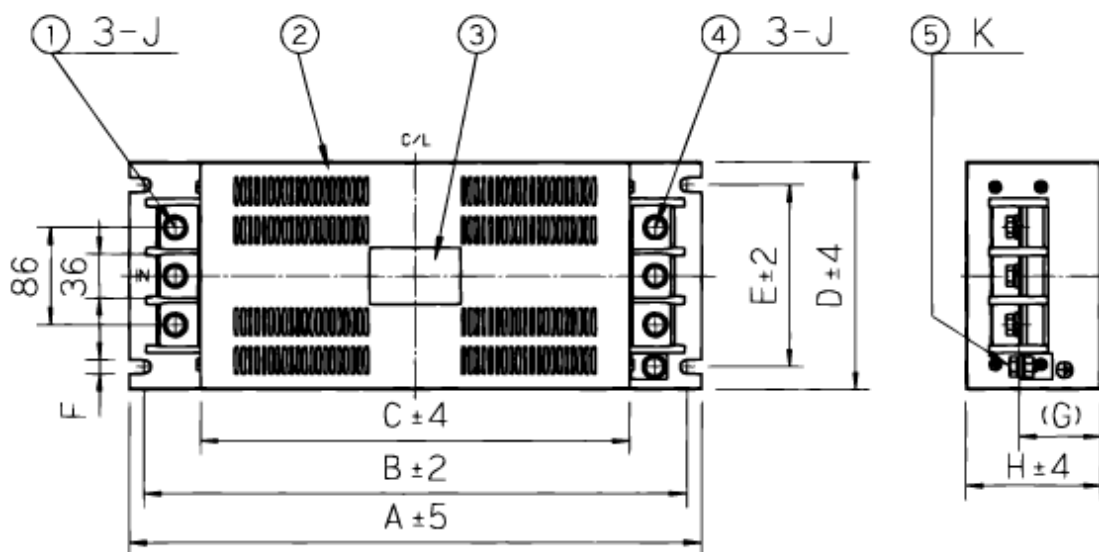
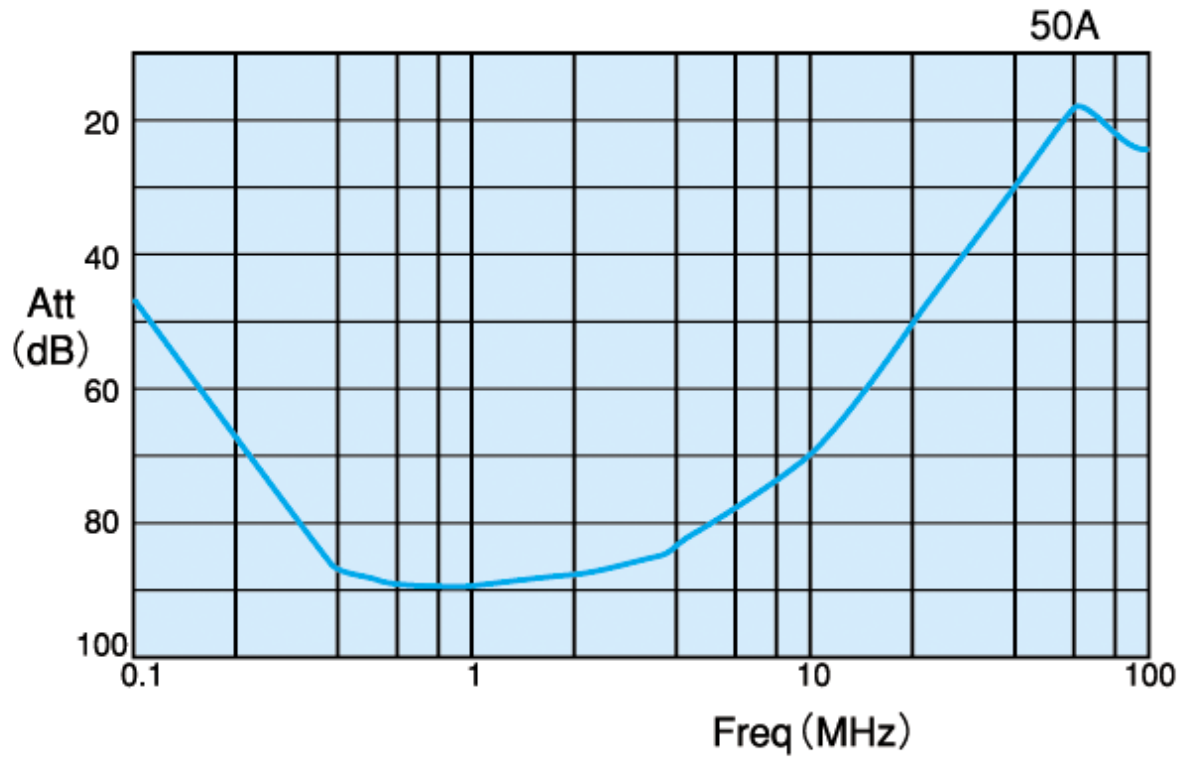

fig. 3 (200, 250, 300A)



Characteristics (Typical)



Circuit Diagram (10, 30A)

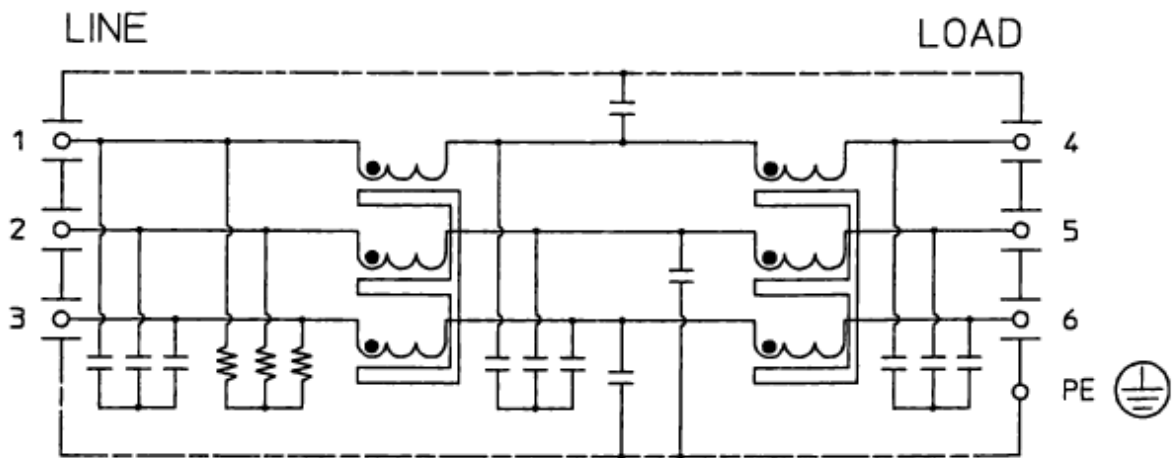

Circuit Diagram (50-300A)

