

RoHS

SPECIFICATIONS

Rated Current:3.0AMP
 Contact Resistance:20mΩ Max
 Withstand Voltage:1000V AC/DC
 Insulation Resistance:1000MΩ Min
 Operation Temperature:-40°C to +105°C

Contact Material:Brass
 Contact Plating:Au or Sn Over Ni
 Insulator Material:Polyester(UL94V-0)
 Standard: PA6T
 Max.Processing Temp: 230°C for 30-60 seconds
 (260°C for 10 seconds)

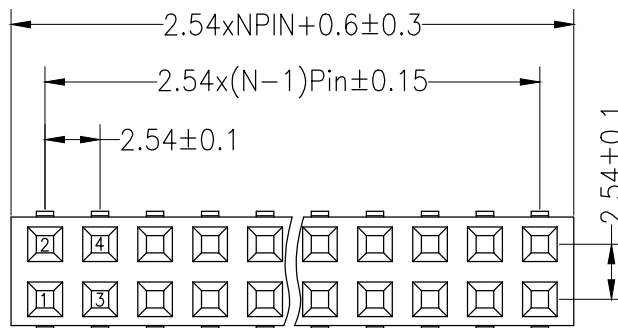

Recommended P.C.B Layout(Top Side)
 (PCB BOARD TOLERANCE±0.05)

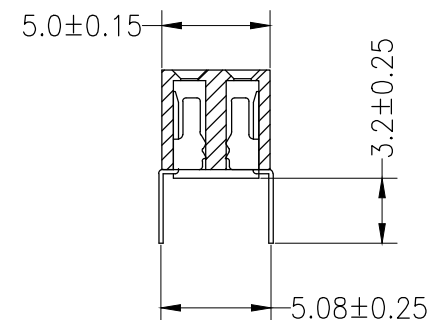
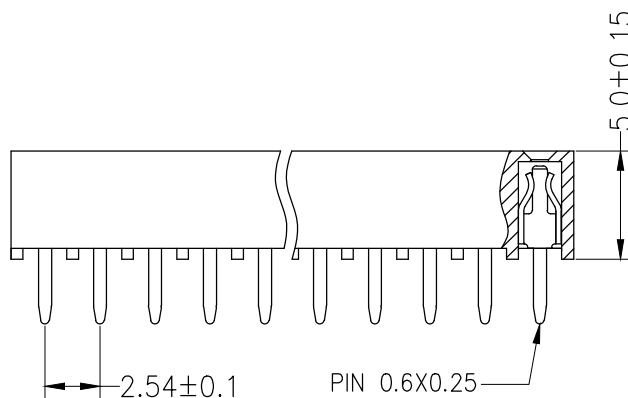
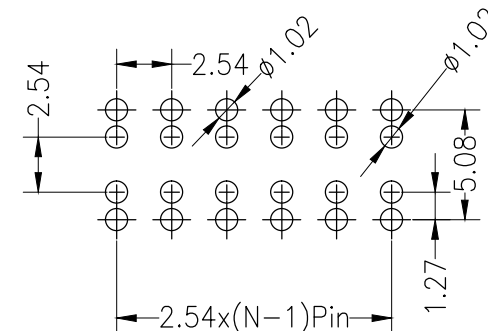

OPERATION

X.X	±0.30
X.XX	±0.20
X.XXX	±0.10
Angle	±3°
DIM	TOL

DRAW

CHECK

APPROVE

SCALE

UNIT

SIZE

SHEET

PROJ.

FIT

mm

A4

1/1

Φ

深圳市连盛精密连接器有限公司

PART NO.

FH-00089

TITLE:

2.54FH H5.0mm 2xNpin W5.00
 Bottom Entry

REV	DATE	MODIFICATION DESCRIPTION	CHANGE
A0	2012.08.06	NEW DRAWING	