



Features

- Available in E6 series
- Unit height of 1.8 mm
- Current up to 2.8 A
- RoHS compliant*

Applications

- Input/output of DC/DC converters
- Power supplies for:
 - Portable communication equipment
 - Camcorders
 - LCD TVs
 - Car radios

SRU5018 Series - Shielded SMD Power Inductors

Electrical Specifications

Bourns Part Number	Inductance @ 100 KHz		Q Ref.	Test Freq. (MHz)	SRF Min. (MHz)	RDC (.mΩ)	I rms Max. (A)	I sat Typ. (A)	**K-Factor
	L (μH)	Tol. (%)							
SRU5018-1R0Y	1.0	±30	9	7.96	200	12.5	2.80	2.85	1105
SRU5018-1R5Y	1.5	±30	9	7.96	160	15.5	2.50	2.40	904
SRU5018-2R2Y	2.2	±30	10	7.96	130	20.5	2.30	2.10	765
SRU5018-3R5Y	3.5	±30	9	7.96	90	32.0	2.10	1.70	585
SRU5018-4R7Y	4.7	±30	8.5	7.96	80	36.0	2.00	1.55	524
SRU5018-6R8Y	6.8	±30	7.5	7.96	60	50.0	1.45	1.20	432
SRU5018-100Y	10.0	±30	12	2.52	50	65.0	1.25	1.05	368
SRU5018-150Y	15.0	±30	12	2.52	40	100.0	0.95	0.80	301
SRU5018-220Y	22.0	±30	12	2.52	28	160.0	0.68	0.65	243
SRU5018-330Y	33.0	±30	13	2.52	23	220.0	0.66	0.56	195
SRU5018-470Y	47.0	±30	13	2.52	18	330.0	0.54	0.45	163
SRU5018-680Y	68.0	±30	12	2.52	16	480.0	0.37	0.36	140
SRU5018-101Y	100.0	±30	15	0.796	15	620.0	0.32	0.31	117

**K-Factor: To calculate core flux density, Bp-p (gauss) = K x L(μH) x Δ I (peak-to-peak ripple current, A), determine core loss from Core Loss vs. Flux Density plot.

Core Loss vs. Flux Density

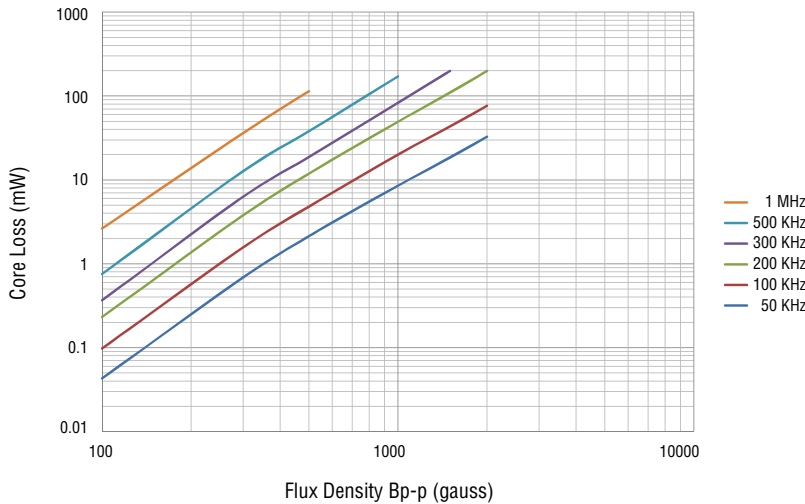

Electrical Schematic

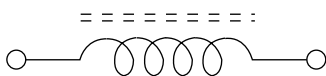

Inductor Connection

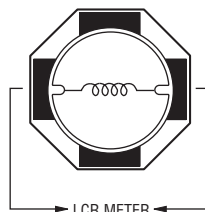

* RoHS Directive 2002/95/EC Jan. 27, 2003 including annex and RoHS Recast 2011/65/EU June 8, 2011. Specifications are subject to change without notice. The device characteristics and parameters in this data sheet can and do vary in different applications and actual device performance may vary over time. Users should verify actual device performance in their specific applications.

General Specifications

Test Voltage 0.1 V
 Reflow Soldering .. 230 °C, 50 sec. max.
 Operating Temp. -40 °C to +125 °C
 (Temperature rise included)
 Storage Temperature... -40 °C to +125 °C
 Resistance to Soldering Heat
 +260 °C for 10 sec.

Materials

Core Ferrite DR and RI core
 Wire Enameled copper
 Terminal Ag/Ni/Sn
 Rated Current.. Ind. drop 35 % typ. at Isat
 Temperature Rise
 30 °C max. at rated I rms
 Packaging 1000 pcs. per reel

Product Dimensions

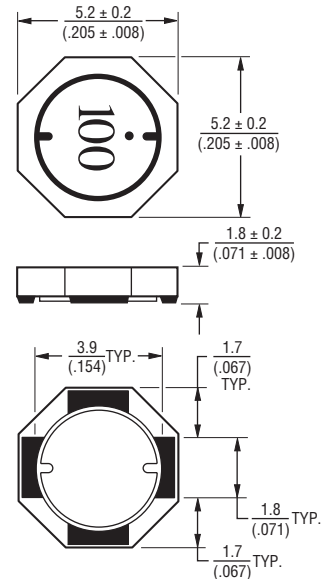

Recommended Layout

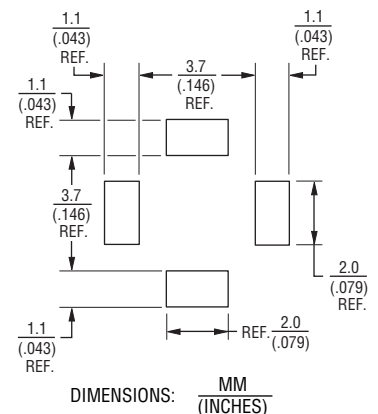

SRU5018 Series - Shielded SMD Power Inductors

BOURNS®

Packaging Specifications

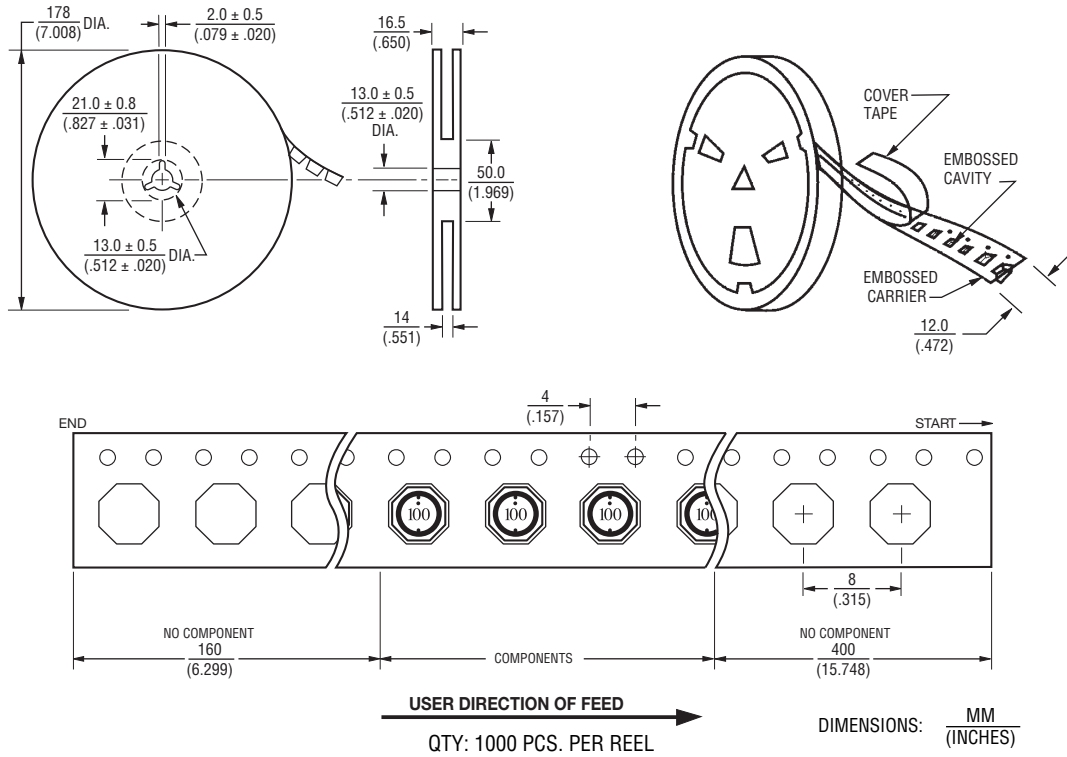

REV. 11/13

Specifications are subject to change without notice.
 The device characteristics and parameters in this data sheet can and do vary in different applications and actual device performance may vary over time.
 Users should verify actual device performance in their specific applications.