

Reducing adapter - REDUC-K-KV-M40/M25 BK - 1410741

Please be informed that the data shown in this PDF Document is generated from our Online Catalog. Please find the complete data in the user's documentation. Our General Terms of Use for Downloads are valid (<http://phoenixcontact.com/download>)



Reducing adapter, material: Polyamide fiberglass reinforced, connecting thread: M40 x 1.5, color: black, with flat gasket

Product Description

Reduced M40 to M25



Key Commercial Data

| | |
|--------------|---|
| Packing unit | 10 pc |
| GTIN |  4 046356 873222 |
| GTIN | 4046356873222 |

Technical data

Dimensions

| | |
|----------------------------------|---------|
| Length | 16 mm |
| Length without connecting thread | 6 mm |
| Connecting thread diameter | 40 mm |
| Wrench size, union nut | 46 mm |
| Hexagon angular dimension | 50.5 mm |
| Length of the connecting thread | 10 mm |

Ambient conditions

| | |
|---------------------------------|---|
| Degree of protection (IP) | IP65 (Depends on the screw connection used) |
| Ambient temperature (operation) | -30 °C ... 100 °C |

General

| | |
|--|---------------------------------|
| Material | Polyamide fiberglass reinforced |
| Outer thread | M40 |
| Internal thread | M25 |
| Torque | 5 Nm ... 7.5 Nm |
| Flammability rating according to UL 94 | HB |

Reducing adapter - REDUC-K-KV-M40/M25 BK - 1410741

Technical data

General

| | |
|-------|-------|
| Color | black |
|-------|-------|

Standards and Regulations

| | |
|--|----|
| Halogen-free | no |
| Flammability rating according to UL 94 | HB |

Environmental Product Compliance

| | |
|------------|---|
| China RoHS | Environmentally friendly use period: unlimited = EFUP-e |
| | No hazardous substances above threshold values |

Drawings

Dimensional drawing

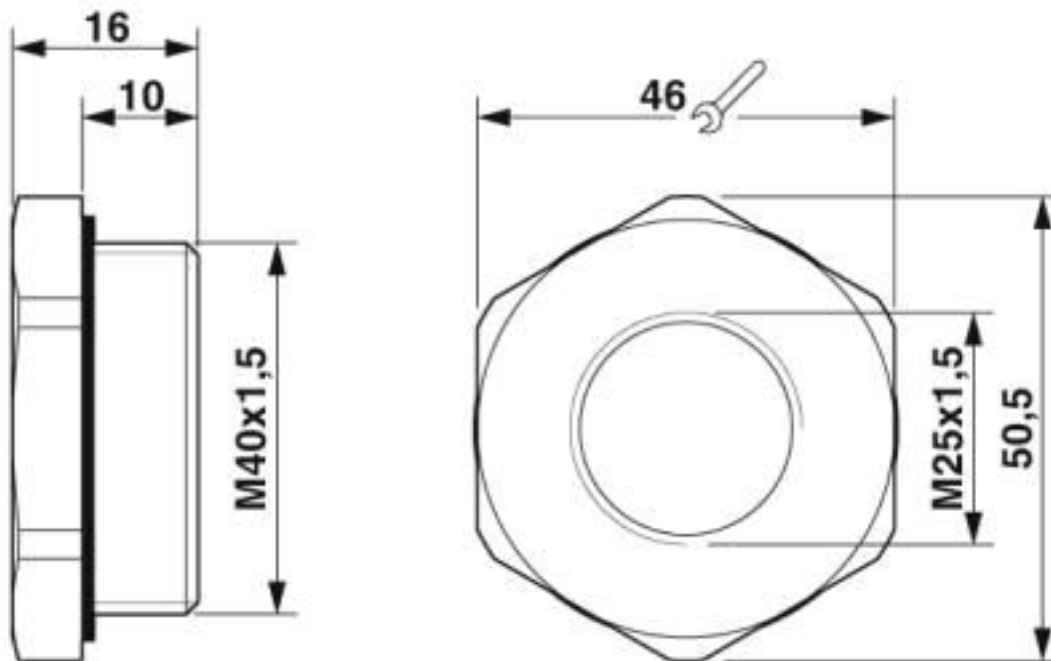

Dimensional drawing

Classifications

eCl@ss

| | |
|---------------|----------|
| eCl@ss 10.0.1 | 27440201 |
| eCl@ss 4.0 | 27141200 |
| eCl@ss 4.1 | 27141200 |
| eCl@ss 5.0 | 27149100 |
| eCl@ss 5.1 | 27149100 |
| eCl@ss 6.0 | 27149100 |

Reducing adapter - REDUC-K-KV-M40/M25 BK - 1410741

Classifications

eCl@ss

| | |
|------------|----------|
| eCl@ss 7.0 | 27149109 |
| eCl@ss 8.0 | 27149109 |
| eCl@ss 9.0 | 27440201 |

ETIM

| | |
|----------|----------|
| ETIM 4.0 | EC000441 |
| ETIM 5.0 | EC000441 |
| ETIM 6.0 | EC002309 |
| ETIM 7.0 | EC002309 |

UNSPSC

| | |
|---------------|----------|
| UNSPSC 6.01 | 30211808 |
| UNSPSC 7.0901 | 39121408 |
| UNSPSC 11 | 39121408 |
| UNSPSC 12.01 | 39121408 |
| UNSPSC 13.2 | 39121311 |
| UNSPSC 18.0 | 31261501 |
| UNSPSC 19.0 | 31261501 |
| UNSPSC 20.0 | 31261501 |
| UNSPSC 21.0 | 31261501 |

Phoenix Contact 2020 © - all rights reserved
<http://www.phoenixcontact.com>

PHOENIX CONTACT GmbH & Co. KG
Flachsmarktstr. 8
32825 Blomberg
Germany
Tel. +49 5235 300
Fax +49 5235 3 41200
<http://www.phoenixcontact.com>