

REV.	ECN. NO.	APPD.
A	BC100059083	Yihsin Chen
B	BC-11-0027885	Yihsin Chen

NOTES:

1. DIMENSIONS SHALL BE INTERPRETED PER ASME Y14.5-2009
 2. ALL DIMENSIONS ARE MILLIMETERS.
 3. SPECIFICATIONS OF PRODUCT ARE SHOWN ON DRAWING "303-0300-2715".
 4. MATERIALS OF PARTS ARE SHOWN ON DRAWING "303-0500-2715".
 5. DATE CODE: "****" REFER TO FOXCONN'S DOC "SQ-3B0-070"
 6. HARMFUL MATERIAL CONTROL PLEASE FOLLOW FOXCONN'S "EPI12".
 7. PLEASE CONTACT FOXCONN SALES REPRESENTATIVE TO VERIFY PRODUCT DETAILS & AVAILABILITY.
 8. THE CONCENTRATIONS OF BR&CL CAN SATISY THE REQUIREMENTS OF HALOGEN FREE IN DOCUMENT "EPI12".
- △ THE " FOXCONN " LOGO IS LOCATED APPROX.AS SHOW.

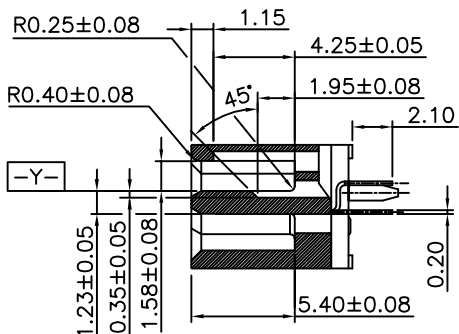
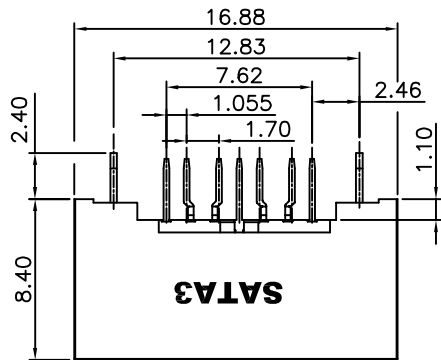

SECTION A-A

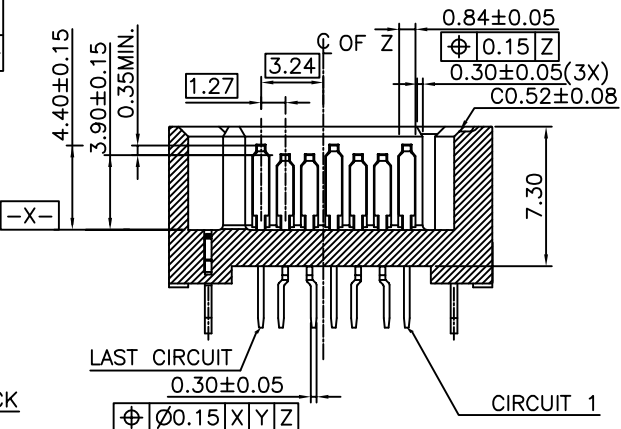
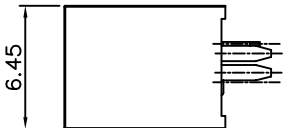
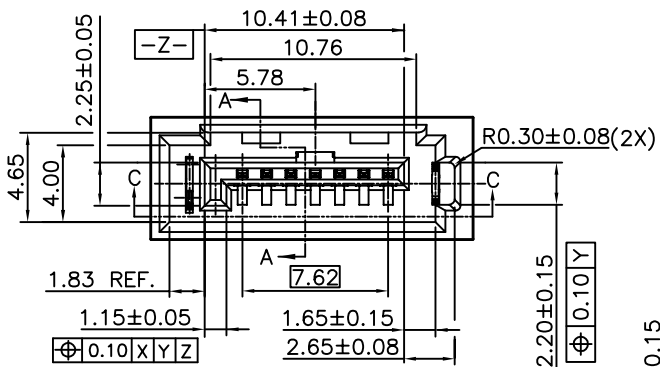

SECTION C-C

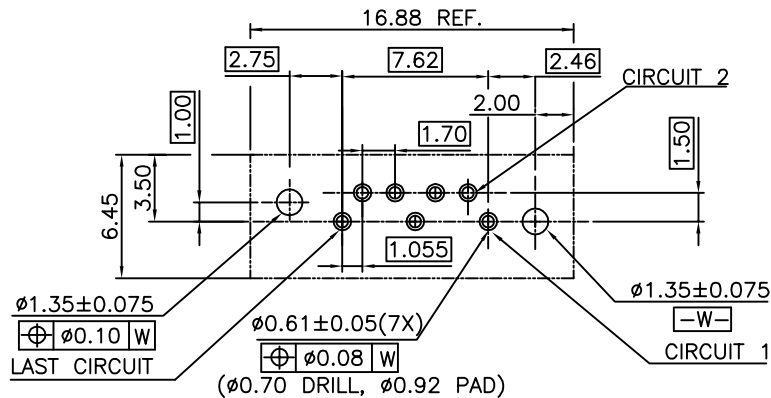
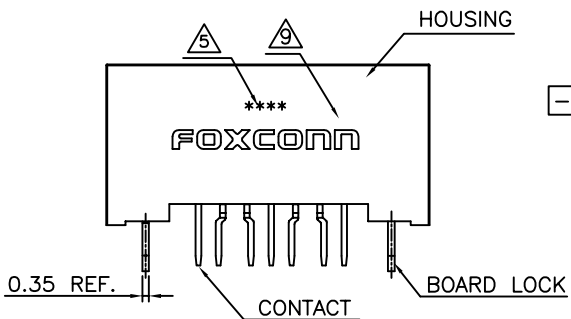

RECOMMENDED P.C.B. LAYOUT

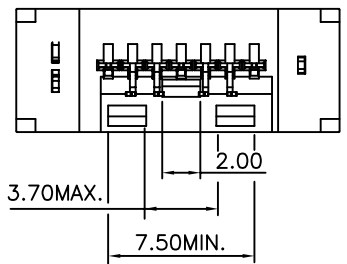

X.±	X'± 1*	UNITS	mm	NAME(INTENDED USE)
.x± 0.25	.x'±	MAT'L		SERIAL ATA
.xx± 0.20	.xx'±			PART NO.(INTENDED USE)
.xxx± 0.15	.xxx'±	FINISH		LE18 SERIAL
THESE DRAWINGS AND SPECIFICATIONS ARE THE PROPERTY OF HON HAI PRECISION IND. CO., LTD. AND SHALL NOT BE REPRODUCED, COPIED OR USED IN ANY MANNER WITHOUT THE PRIOR WRITTEN CONSENT OF HON HAI PRECISION IND. CO., LTD.				APPD: Yusan Hsiao
				CHKD: Wolfe Liu
				DR: Dongmei Zhao _{6/26'12}
Q'TY				

P/N	LE1807*~**0*~**
FOXCONN	
HON HAI PRECISION IND. CO.,LTD. TAIPEI, TAIWAN, R.O.C.	
TITLE: CUSTOMER DRAWING, 7 POS. VERTICAL T/H, SHROUDED PLUG	
DWG NO.: 303-0000-2659	
SCALE	SHEET
N/A	1/4
REV.	BOX2

REV.	ECN. NO.	NO.	APPD.

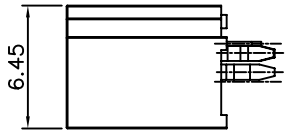
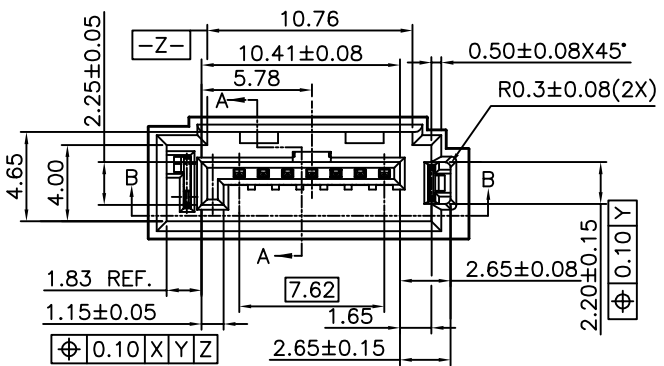
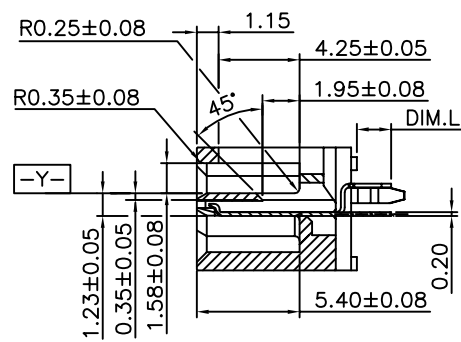
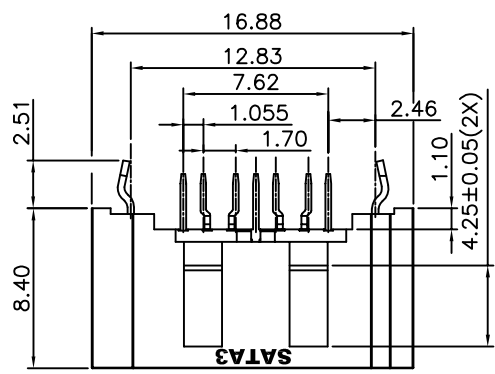

SECTION A-A

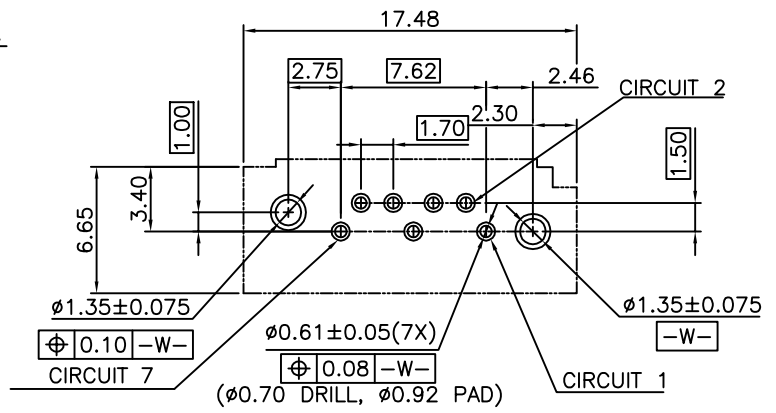

RECOMMENDED P.C.B. LAYOUT

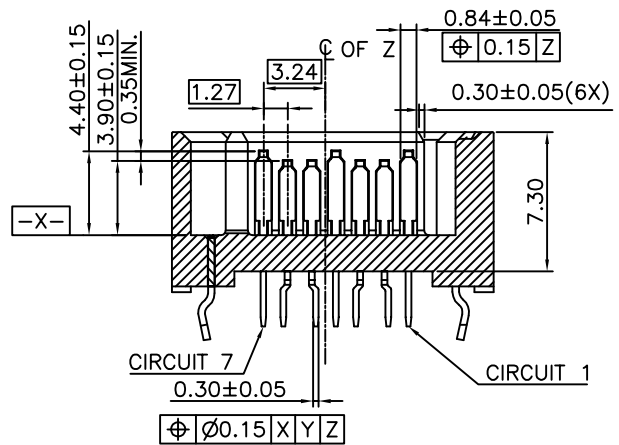

SECTION B-B

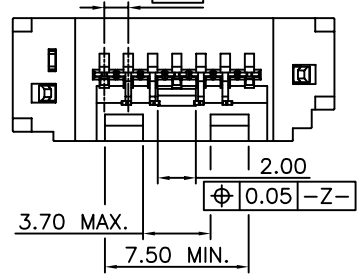
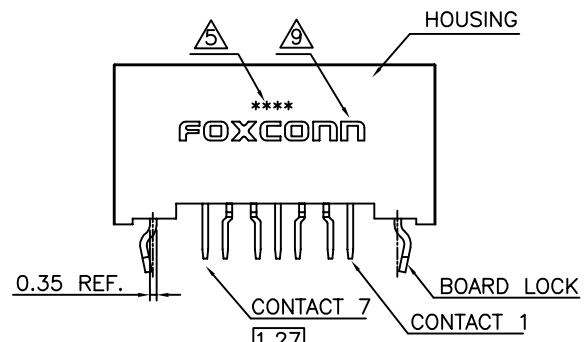

x.±	x'.± 1*	UNITS	mm	NAME(INTENDED USE)
.x± 0.25	.x'±	MAT'L		SERIAL ATA
.xx± 0.20	.xx'±			PART NO.(INTENDED USE)
.xxx± 0.15	.xxx'±	FINISH		LE18 SERIAL
<small>THESE DRAWINGS AND SPECIFICATIONS ARE THE PROPERTY OF HON HAI PRECISION IND. CO., LTD. AND SHALL NOT BE REPRODUCED, COPIED OR USED IN ANY MANNER WITHOUT THE PRIOR WRITTEN CONSENT OF HON HAI PRECISION IND. CO., LTD.</small>				APPD: Yusan Hsiao
				CHKD: Wolfe Liu
				DR: Dongmei Zhao _{8/28*12}
Q'TY				

P/N	LE1807*_*2*_*		
FOXCONN			
HON HAI PRECISION IND. CO.,LTD. TAIPEI, TAIWAN, R.O.C.			
TITLE:		CUSTOMER DRAWING, 7 POS. VERTICAL T/H, SHROUDED PLUG	
APPD:		Yusan Hsiao	
CHKD:		Wolfe Liu	
DR:		Dongmei Zhao _{8/28*12}	
DWG NO.: 303-0000-2659			
	SCALE	SHEET	REV.
	1:1	2/4	BX2

REV.	ECN.	NO.	APPD.

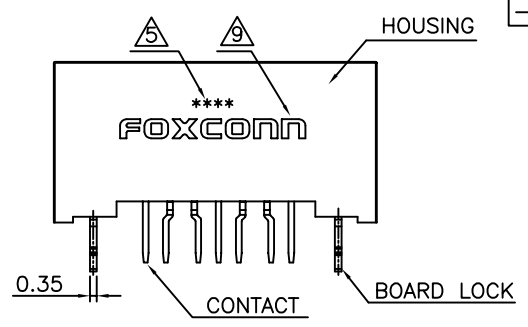
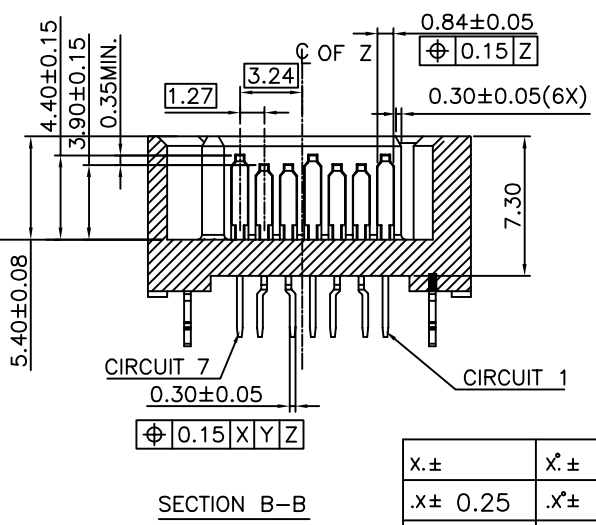
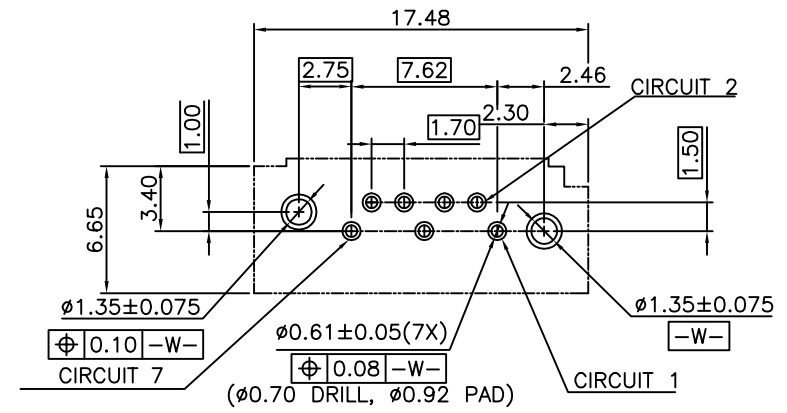
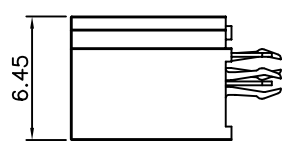
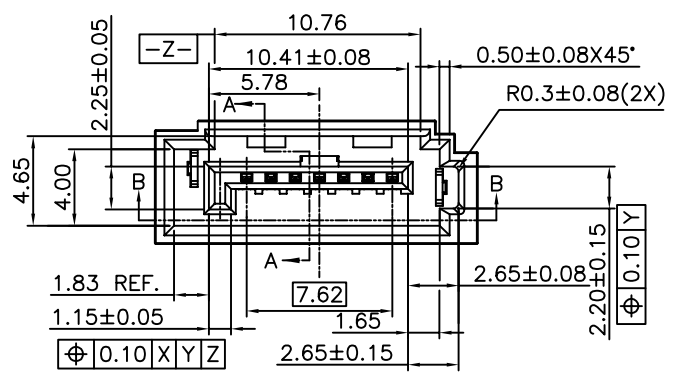
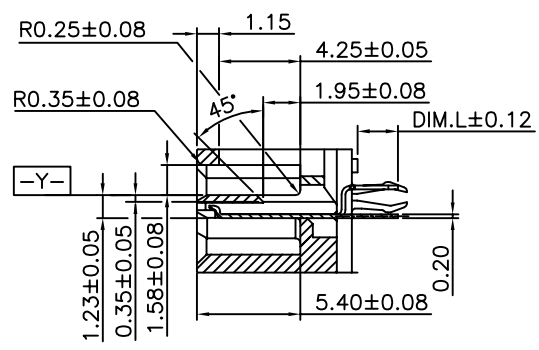
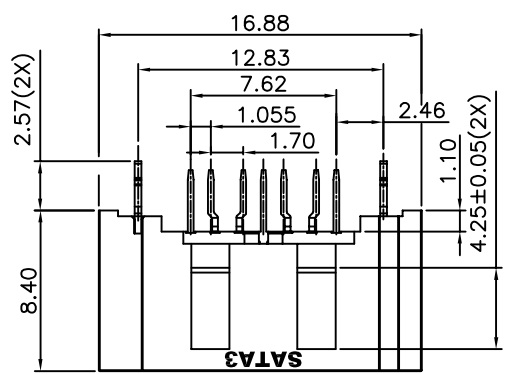

X.±	X'.± 1°	UNITS	mm	NAME(INTENDED USE)	P/N	LE1807*-**3*-**	
.x± 0.25	.x'±	MAT'L		SERIAL ATA	FOXCONN HON HAI PRECISION IND. CO.,LTD. TAIPEI, TAIWAN, R.O.C.		
.xx± 0.20	.xx'±	FINISH		PART NO.(INTENDED USE)		TITLE:	
.xxx± 0.15	.xxx'±			LE1807*-****-**		CUSTOMER DRAWING, 7 POS.	
THESE DRAWINGS AND SPECIFICATIONS ARE THE PROPERTY OF HON HAI PRECISION IND. CO., LTD. AND SHALL NOT BE REPRODUCED, COPIED OR USED IN ANY MANNER WITHOUT THE PRIOR WRITTEN CONSENT OF HON HAI PRECISION IND. CO., LTD.				APPD: Yusan Hsiao	DWG NO.:	303-0000-2659	
				Q'TY	CHKD: Wolfe Liu	SCALE	SHEET
				DR: Dongmei Zhao _{6/26'12}	1:1	3/4	BX2

REV.	ECN.	NO.	APPD.

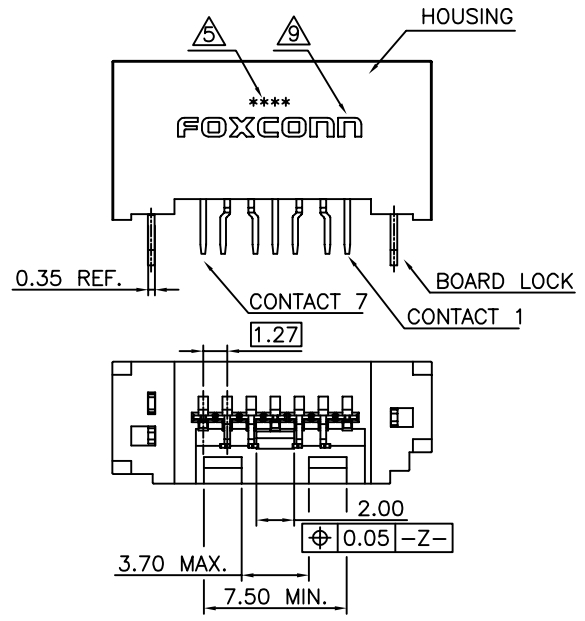
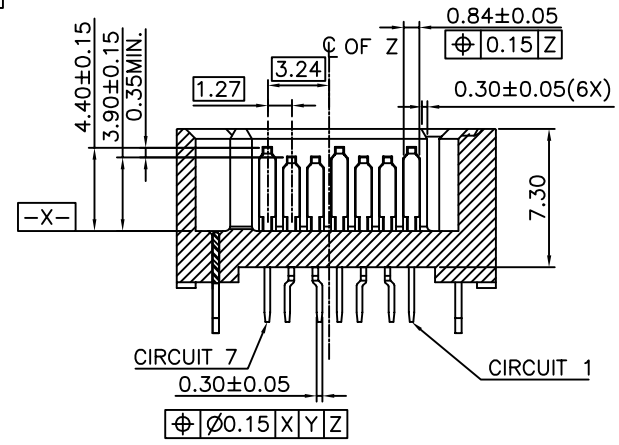
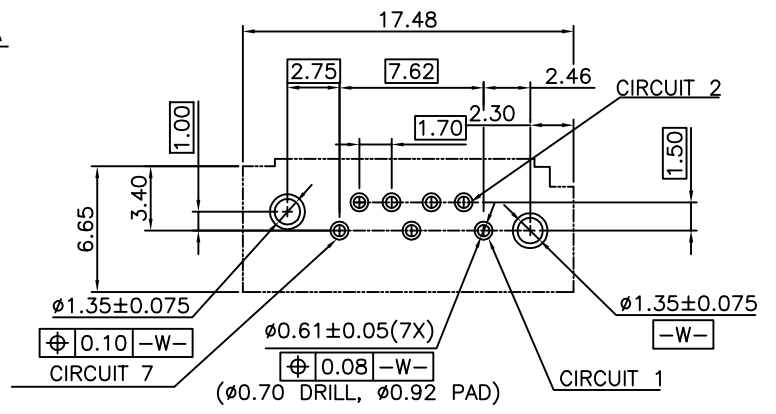
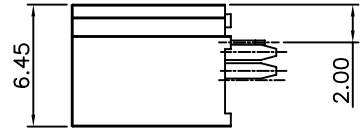
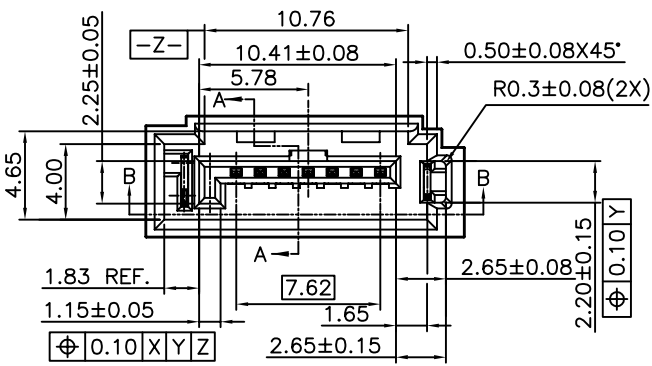
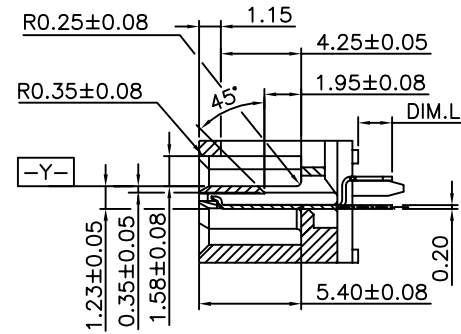
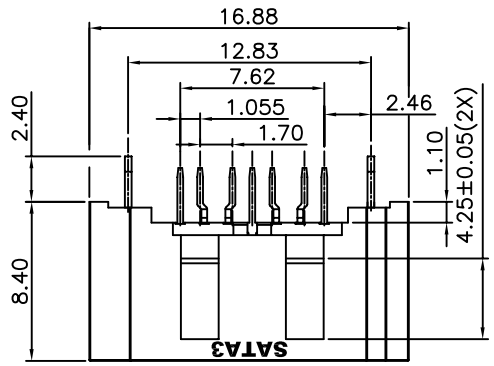

x.±	x'.± 1°	UNITS	mm
.x± 0.25	.x'±	MAT'L	
.xx± 0.20	.xx'±	FINISH	
.xxx± 0.15	.xxx'±	Q'TY	

THESE DRAWINGS AND SPECIFICATIONS ARE THE PROPERTY OF HON HAI PRECISION IND. CO., LTD. AND SHALL NOT BE REPRODUCED, COPIED OR USED IN ANY MANNER WITHOUT THE PRIOR WRITTEN CONSENT OF HON HAI PRECISION IND. CO., LTD.

NAME(INTENDED USE)	SERIAL ATA
PART NO.(INTENDED USE)	LE18 SERIAL
APPD:	Yusan Hsiao
CHKD:	Wolfe Liu
DR:	Dongmei Zhao _{6/26'12}

P/N	LE1807*-***4*-**	
FOXCONN	HON HAI PRECISION IND. CO.,LTD. TAIPEI, TAIWAN, R.O.C.	
TITLE:	CUSTOMER DRAWING, 7 POS. VERTICAL T/H, SHROUDED PLUG	
DWG NO.:	303-0000-2659	
SCALE	SHEET	REV.
1:1	4/4	BX2

ITEM	DESC.	Q'TY	MATERIAL	TREATMENT	REMARK
1	HOUSING	1	THERMOPLASTIC UL 94V-0		
2	CONTACT	SEE NOTE BELOW	COPPER ALLOY	A) NICKEL UNDER PLATING OVER ALL THICKNESS : 50 u" MIN. . B) MATTE TIN PLATING OVER NICKEL THICKNESS : 100 u" MIN. . ON SOLDER AREA. C) GOLD PLATING OVER NICKEL ON CONTACT AREA(SEE NOTES BELOW)	
3	BOARD LOCK	2	MEDIUM CARBON STEEL	A) NICKEL PLATING OVER ALL THICKNESS : 50 u" MIN. . B) MATTE TIN PLATING OVER NICKEL. THICKNESS : 100 u" MIN. .	

NOTE : 1.HARMFUL MATERIAL CONTROL PLEASE FOLLOW FOXCONN'S DOC. "EPI12".
2.PLEASE CONTACT FOXCONN SALES REPRESENTATIVE TO VERIFY PRODUCT
DETAILS & AVAILABILITY.
3.PRODUCT NO. MATRIX:

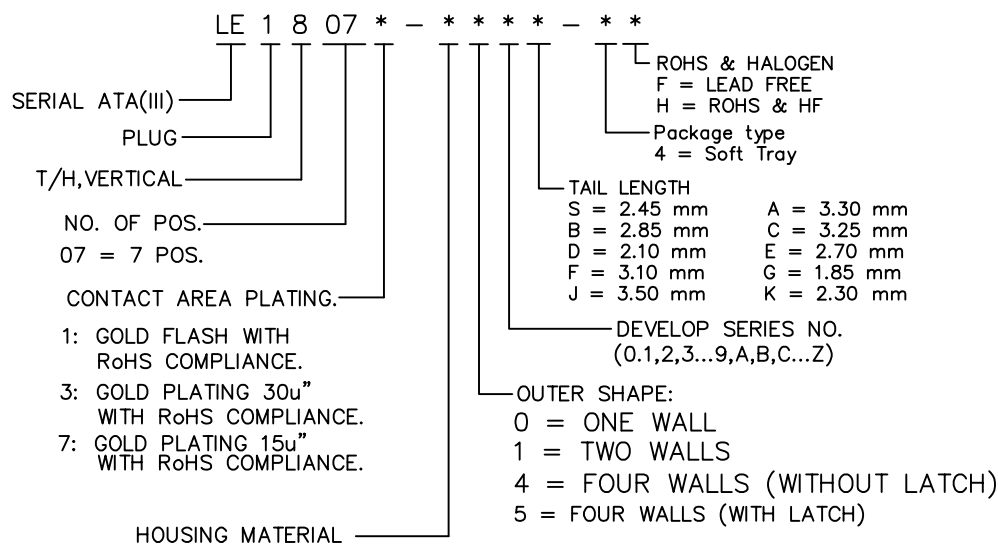

A = THERMAL PLASTIC, COLOR:BLACK	P = THERMAL PLASTIC,COLOR:WHITE	4 = THERMAL PLASTIC,COLOR:BLUE
C = THERMAL PLASTIC, COLOR:YELLOW	Q = THERMAL PLASTIC,COLOR:ORANGE	5 = THERMAL PLASTIC,COLOR:RED
D = HIGH TEMP. PLASTIC, COLOR:IVORY	R = HIGH TEMP. PLASTIC, COLOR RED	7 = THERMAL PLASTIC,COLOR:ORANGE
E = HIGH TEMP. PLASTIC, COLOR:BLUE	S = THERMAL PLASTIC,COLOR:ORANGE	8 = THERMAL PLASTIC,COLOR:GRAY
G = THERMAL PLASTIC,COLOR:BLUE	T = HIGH TEMP. PLASTIC,COLOR:BLACK	9 = LCP,COLOR: WHITE
H = HIGH TEMP.PLASTIC,COLOR:YELLOW	U = HIGH TEMP. PLASTIC,COLOR:BLUE	
K = HIGH TEMP.PLASTIC,COLOR: WHITE	W = THERMAL PLASTIC,COLOR:NATURE	
L = LCP,COLOR:BLACK	Y = THERMAL PLASTIC,COLOR:BEIGE	
M = THERMAL PLASTIC,COLOR:CHARCOAL	Z = THERMAL PLASTIC,COLOR:BLUE	
N = THERMAL PLASTIC,,COLOR:BLUE	3 = THERMAL PLASTIC,COLOR:GRAY	

4. THE CONCENTRATIONS OF BR&CL CAN SATISY THE REQUIREMENTS
OF HALOGEN FREE IN DOCUMENT "EPI12".

FOXCONN HON HAI PRECISION IND. CO.,LTD.
TAIPEI, TAIWAN, R.O.C.

APPD. :	TITLE : MATERIAL SHEET T/H, VERTICAL,7 POS., PLUG
CHKD. :	PROD. SERIES: LE1807*-****-***
DR. :	DWG. NO : 303-0500-2659
	REV. : AX1 SHEET : 1/1

A	BC100060390	Yihsin Chen
REV.	ECN NO.	APPD.

SPECIFICATIONS :

1. MATERIAL AND FINISH :

1-1. HOUSING :

THERMOPLASTIC , UL94V-0

1-2. CONTACT :

COPPER ALLOY, NICKEL UNDER PLATING OVER ALL, THICKNESS 50u" MIN. ,
 MATTE TIN PLATING OVER NICKEL, THICKNESS 100u"MIN. ON SOLDER AREA,
 GOLD PLATING OVER NICKEL ON CONTACT AREA,

1-3. BOARD LOCK :

MEDIUM CARBON STEEL, NICKEL UNDER PLATING OVER ALL, THICKNESS 50u" MIN. ,
 MATTE TIN PLATING OVER ALL, THICKNESS 100u"MIN. .

1-4. HARMFUL MATERIAL CONTROL PLEASE FOLLOW DOC. EPI12.

2. PERFORMANCE :

2-1. CURRENT RATING : 1.5 Amps MAX. PER PIN.

2-2. OPERATING TEMPERATURE : -55°C TO +85°C.

3. ELECTRICAL :

3-1. LOW LEVEL CONTACT RESISTANCE(DRY CIRCUIT) : 30 MILLIOHMS MAX. INITIAL.

3-2. DIELECTRIC WITHSTANDING VOLTAGE : 500 VAC. AT SEA LEVEL.

3-3. INSULATION RESISTANCE : 1000 MEGAOHMS MIN. INITIAL.

4. MECHANICAL :

4-1. INSERTION FORCE: EIA-364-13, 45N MAX. .

4-2. REMOVAL FORCE: EIA-364-13, 10N MIN. .

4-3. DURABILITY: 50 CYCLES

5. ENVIRONMENTAL :

5-1. PHYSICAL SHOCK: PASS EIA-364-27, CONDITION H.

5-2. VIBRATION: PASS EIA-364-28, CONDITION V TEST LETTER A.

5-3. HUMIDITY: PASS EIA-364-31, METHOD II TEST CONDITION A.

6. PLEASE CONTACT FOXCONN SALES REPRESENTATIVE TO VERIFY
 PRODUCT DETAILS & AVAILABILITY.

7. THE CONCENTRATIONS OF BR&CL CAN SATISY THE REQUIREMENTS
 OF HALOGEN FREE IN DOCUMENT "EPI12".

FOXCONN HON HAI PRECISION IND. CO.,LTD.
 TAIPEI, TAIWAN, R.O.C.

APPD. : Yihsin Chen	TITLE : SPECIFICATION, 7 POS. VERTICAL T/H, HOST PLUG, SATA
CHKD. : Wolfe Liu	PROD. SERIES : LE1807*-****-**
DR. : Ben.Luo 6/01'10	DWG. No : 303-0300-2659
	REV. : A SHEET : 1/1

A	BC100060375	Yihsin Chen
REV.	ECN No.	APPD.