

797-204
Series 79 Micro-Crimp Hermetic Receptacle
Pre-Wired Pin Contacts
Shell Size G-33

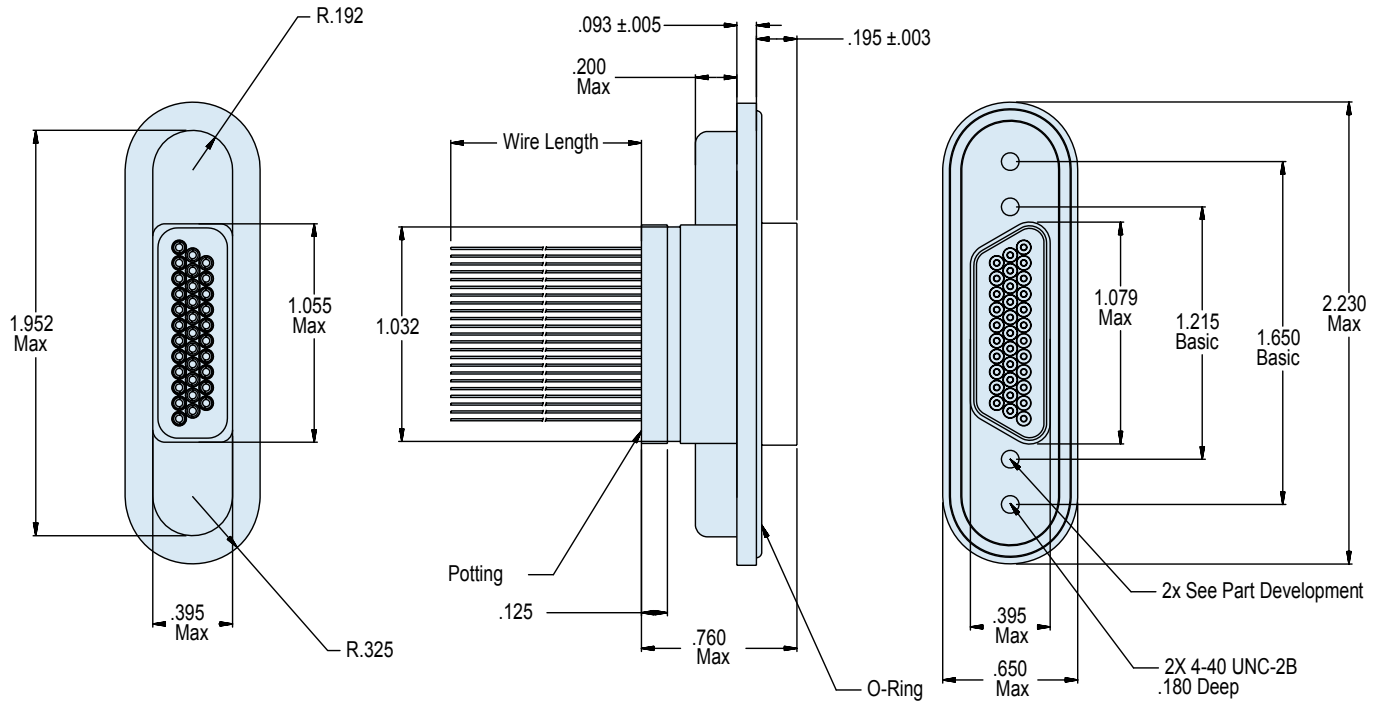

Series 79
Micro-Crimp

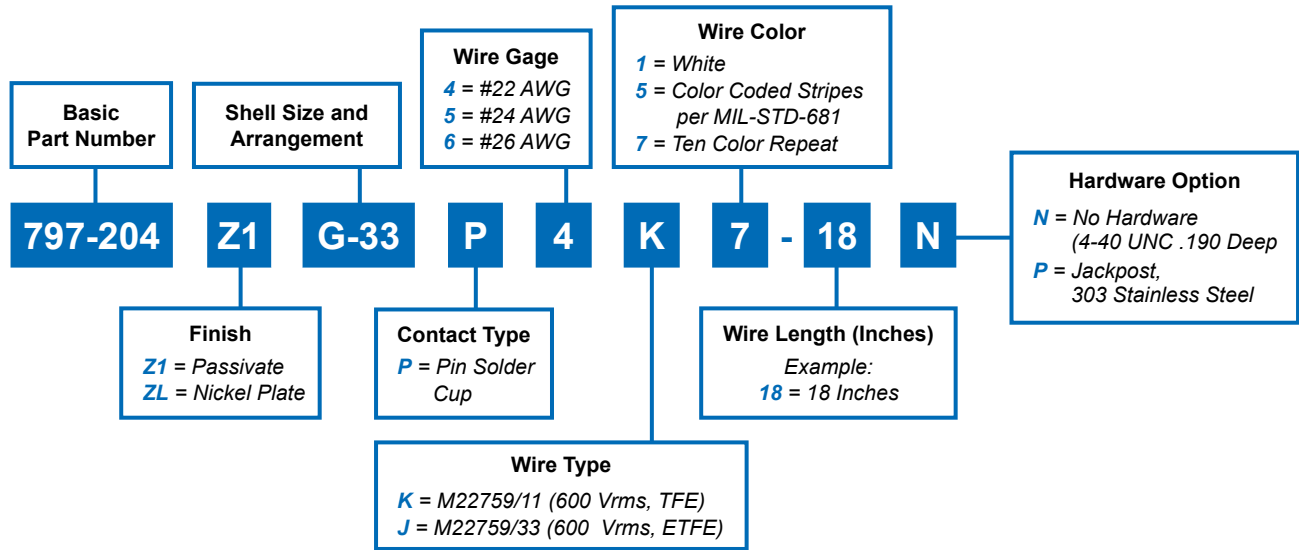

L

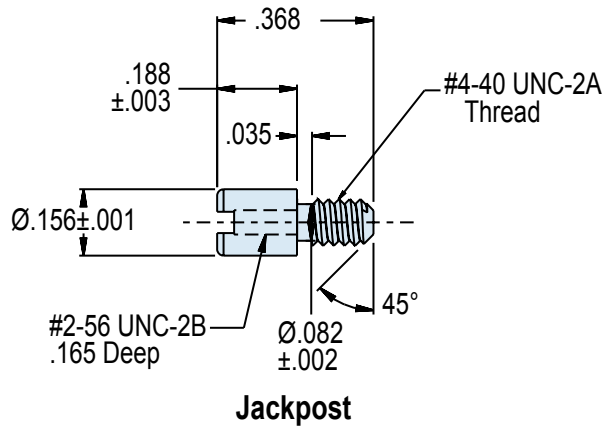
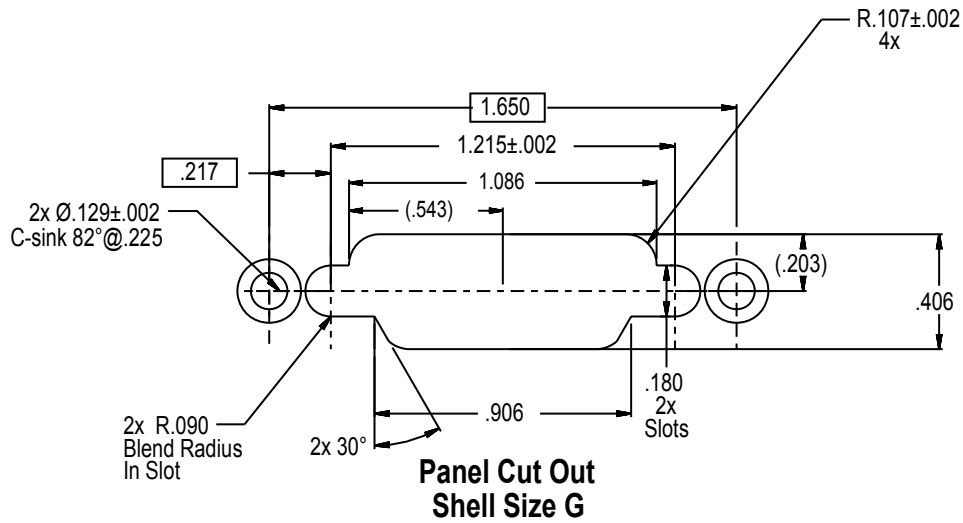

APPLICATION NOTES

- Material/Finish:
 Shell* - 300 Series CRES/passivate or 300 Series CRES/Nickel Plate
 Contacts - Nickel iron alloy/gold plate
 Insulators - Glass bead/N.A.
 Interfacial Seal - Fluorosilicone elastomer/N.A.
 O-Ring - Butyl/N.A.
 Potting - Stycast 2651 epoxy/N.A.
 *Consult factory for other shell finishes and O-Ring materials.
- Metric dimensions (mm) are indicated in parentheses.
- Performance:
 Hermeticity - $<1 \times 10^{-7}$ scc He/sec @1 ATM Delta
 DWV - 500 VAC pin-to-shell
 I.R. - 5,000 megohms minimum @500 VDC
 Temperature - -55°C to +155°C
- Glenair 797-204 receptacle will mate with series 79 series plug having a G-33 insert.