

**QR-50AF SPST, .25 Amp, 115 VAC**

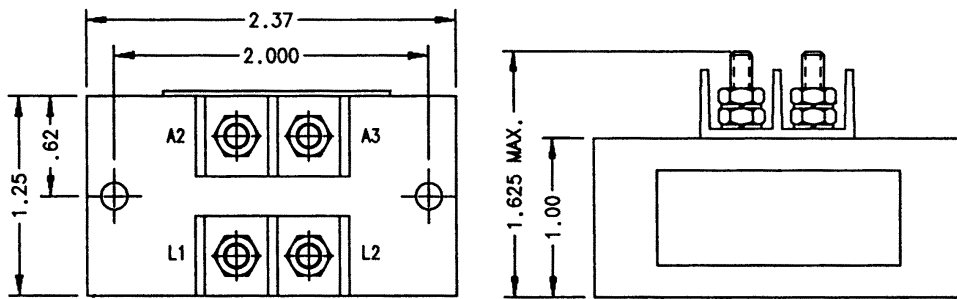

**Features:**

- SPST Main Contacts
- Current Indicator
- Epoxy Encapsulated
- 115 VAC
- .25 Amp
- High Reliability
- Meets many requirements of MIL-R-6106
- Light Weight Construction



**CONTACTOR CONFIGURATION**

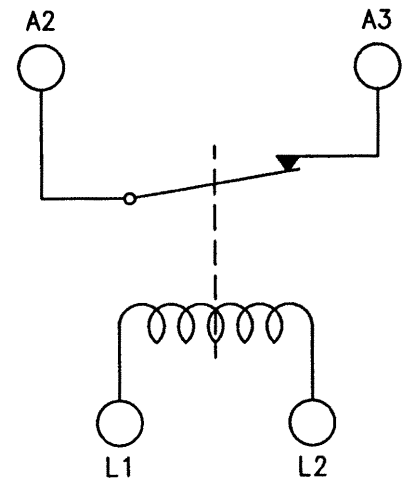

Dimensions for this product are expressed in inches. Multiply values by 25.4 for millimeters.

**PRODUCT SPECIFICATIONS**

Operating Characteristics	
Pick-Up	.5 Amp AC Maximum
Drop-Out	.1 Amp AC Minimum
Continuous	15 Amps AC Maximum
Weight Maximum	4 Oz.
Temperature	-55°C to +71°C
Vibration	10 G'S to 500 Hz
Altitude	50,000 Feet Maximum
Contact Rating	.25 Amp 28 VDC
Lamp Load	.080 Amp 28 VDC

**Notes:**

For factory-direct application assistance, contact the HARTMAN product team at (419) 521-9500, Fax (419) 526-2749.

© 2004 by Tyco Electronics Corporation. All Rights Reserved. HARTMAN and TYCO are trademarks.