

Ansaughaube
hood

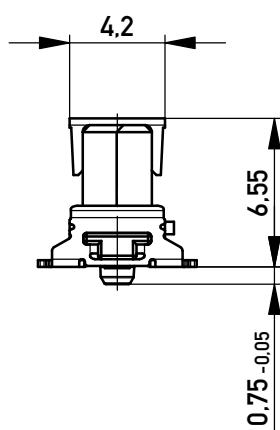

ohne Ansaughaube - without hood

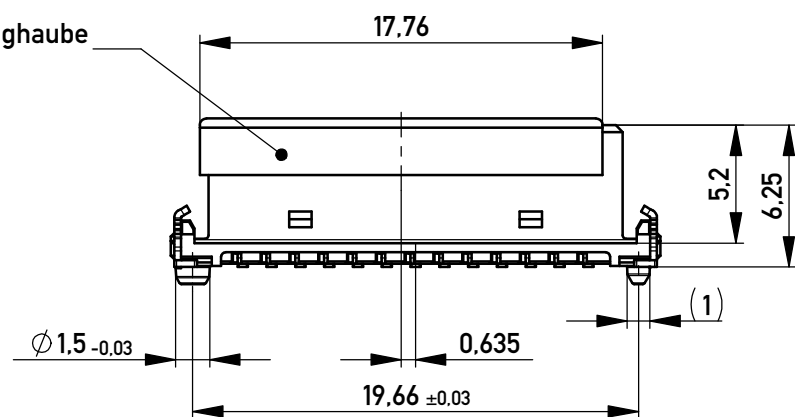
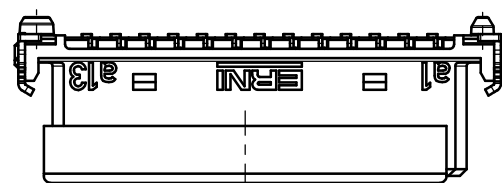
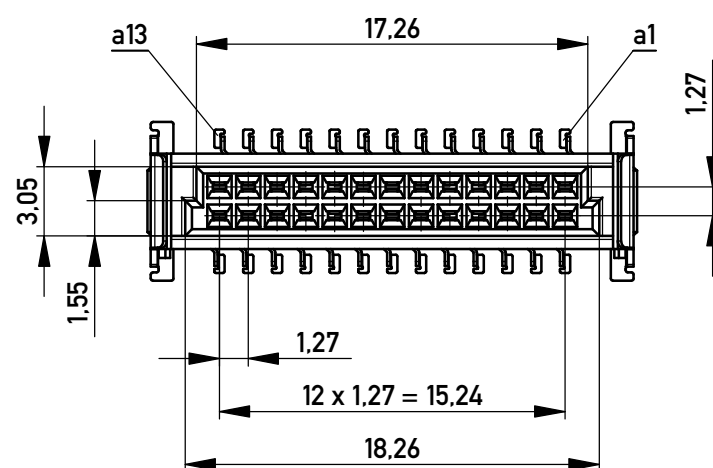
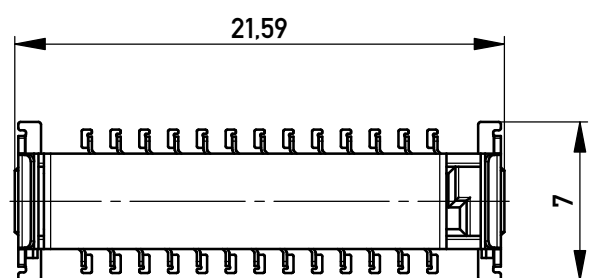

Leiterplatten-Layout Vorschlag für SMT
PCB-Layout Proposal for SMT

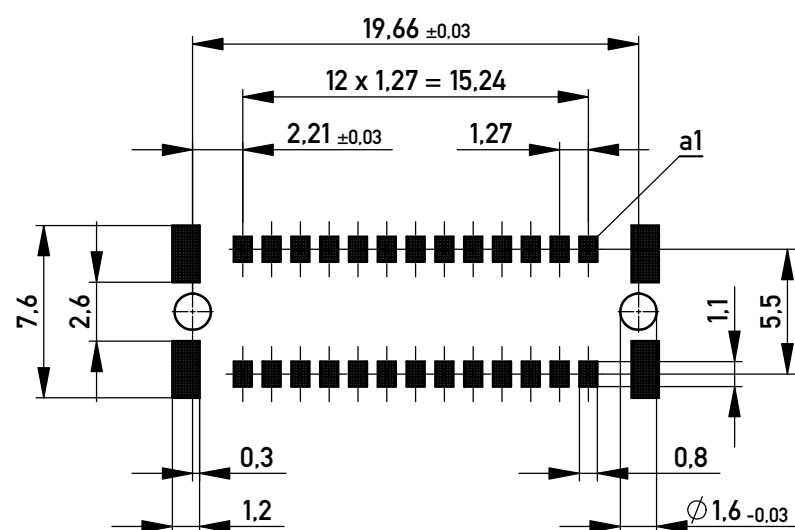

Anforderungsstufe 1
Performance Level 1

Kontaktbereich vergoldet
Mating Area gold plating

Anschlussbereich verzinkt 4-6 µm
Terminal Area 4-6 µm tin plating

Koplanarität der Anschlüsse ≤ 0,1 mm
Coplanarity Area of Termination ≤ 0,1 mm

Verpackt im Gurt nach DIN IEC 60286-3
Tape on Reel Packaging according to DIN IEC 60286-3
Verpackungseinheit: 280 Stück
Packaging unit: 280 pcs

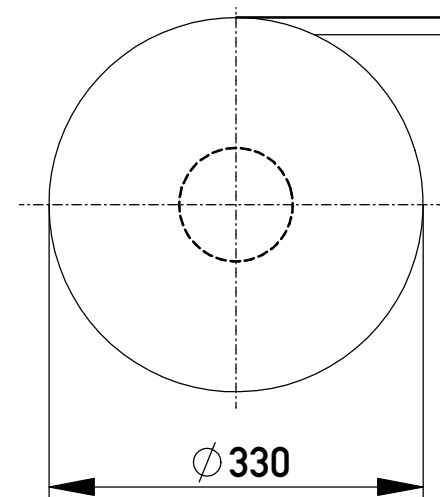

Abspulrichtung - Reel off Direction

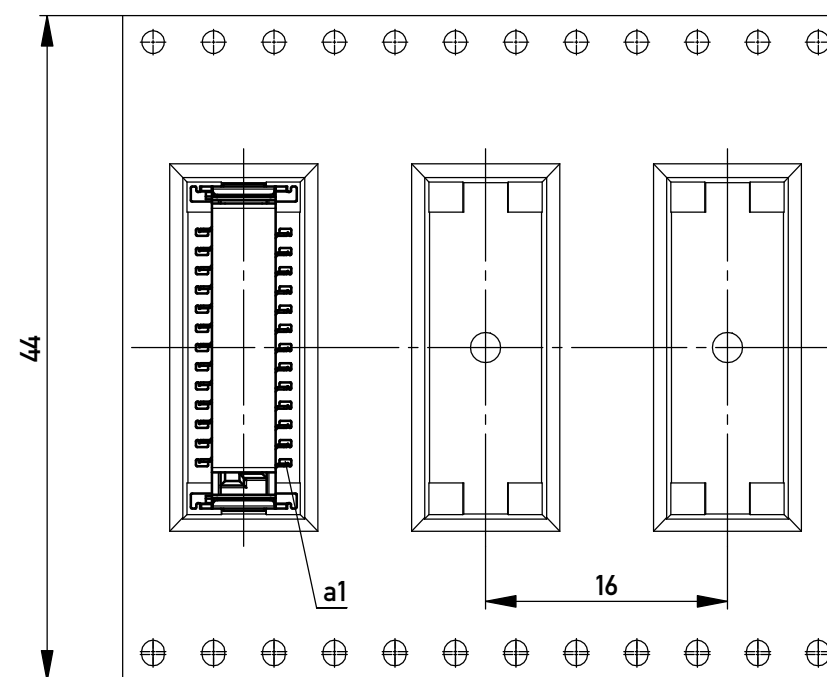

BA 7-13 - 8mm Bauhöhe

type7-13 - Low Profile

Copyright by ERNI GmbH
Proprietary notice pursuant to ISO 16016 to be observed.

Information:		Tolerances	Scale 3:1	All Dimensions in mm	
All rights reserved. Only for Information. To ensure that this is the latest version of this drawing, please contact one of the ERNI companies before using.		Subject to modification without prior notice. Drawing will not be updated.	Designation Federl. SMC-B 26-SMD-BA7-13 Female SMC-B 26-SMD-type7-13		
www.ERNI.com		100404120001		K	
Date 11.06.2015		Class SMCB		A3	