

250-009 Shorting Plug for MIL-DTL-38999 Series I Type Connectors

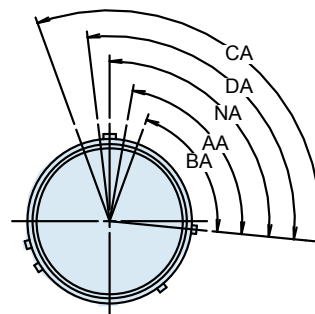
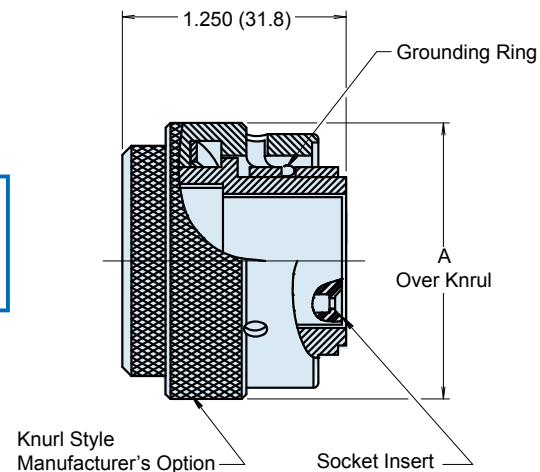
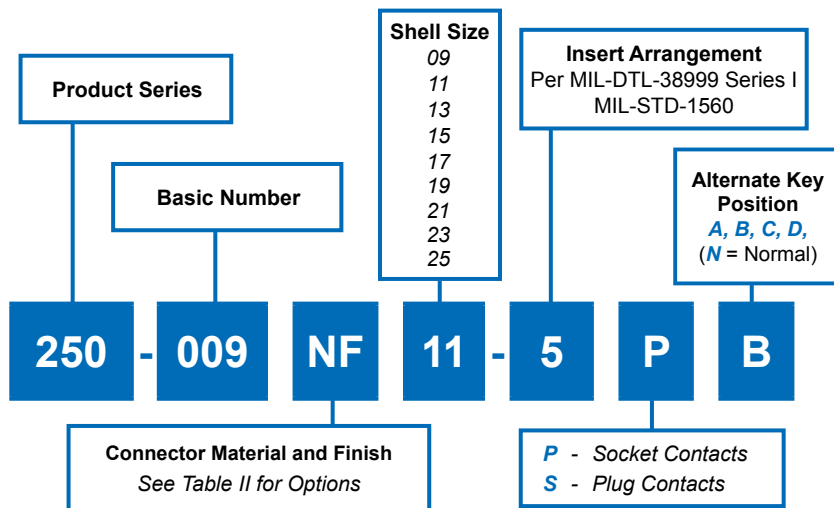

Figure I
Master Keyway Position
Face View Shown
Insert Arrangement Does
Not Rotate with Master Keyway

TABLE I: CONNECTOR DIMENSIONS AND ALTERNATE KEYWAY POSITIONS						
SHELL SIZE	A MAX	ALTERNATE KEYWAY POSITIONS				
		NA	AA	BA	CA	DA
09	.900 (22.9)	95A	77A	-	-	113A
11	1.030 (26.2)	95A	81A	67A	123A	109A
13	1.205 (30.6)	95A	75A	63A	127A	115A
15	1.325 (33.7)	95A	74A	61A	129A	116A
17	1.450 (36.8)	95A	77A	65A	125A	113A
19	1.565 (39.8)	95A	77A	65A	125A	113A
21	1.690 (42.9)	95A	77A	65A	125A	113A
23	1.795 (45.6)	95A	80A	69A	121A	110A
25	1.920 (48.8)	95A	80A	69A	121A	110A

TABLE II: FINISH	
SYM	FINISH
B	Cadmium Plate/Olive Drab
M	Electroless Nickel
N	Cadmium O.D. Over Nickel Plate I
NF	Cadmium O.D. Over Electroless Nickel (500 Hr. Salt Spray)
MT	Ni-PTFE 1000 Hour Grey™ (Nickel Fluorocarbon Polymer)

APPLICATION NOTES

- Assembly identified with manufacturer's name and part number, space permitting.
- All contacts are shorted to each other and to the shell, maximum resistance between contacts and shell shall be 2.5 milliohms.
- Material/finish:
Barrel, coupling nut, cover—aluminum alloy/See Table II.
- Contacts, grounding ring—copper alloy/gold plate
Grounding wafer—copper/tin plate
Wave washer—CRES/passivate
Insulators—high grade dielectric/N.A.
Compression disc, o-ring—silicone/N.A.
- Metric Dimensions (mm) are indicated in parentheses.