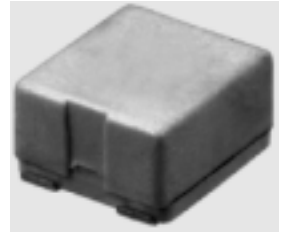
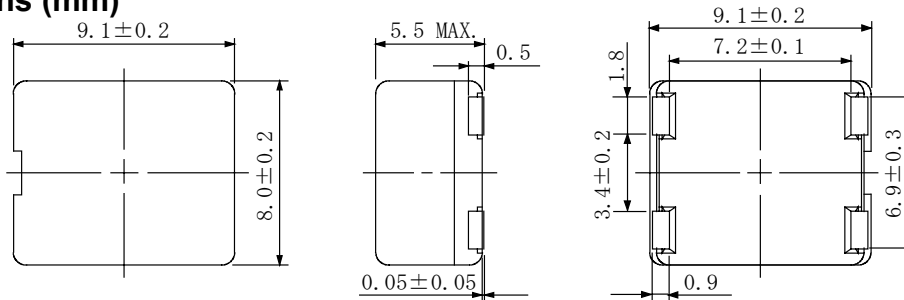
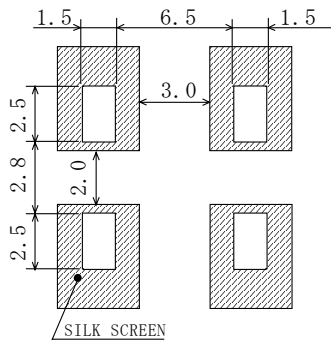
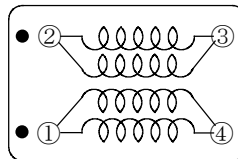

**Type: CPFC85**
**◆ Product Description**

- 9.3 × 8.2mm Max.(L × W), 5.5mm Max. Height .

**◆ Feature**

- Ideally used as EMC common mode choke and xDSL CO transformer.
- RoHS Compliance.

**◆ Dimensions (mm)**

**◆ Land Pattern (mm)**

**◆ Schematics (Bottom)**

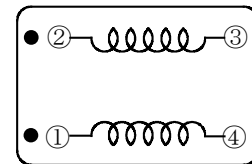
● MARK OF POLARITY

For partname: CPFC85NP-100M03  
CPFC85NP-100M10



● Mark of polarity

For partname: CPFC85-1M15NP

**◆ Specification (For xDSL CO Transformer Use)**

Part Name	Core Material	Stamp	Impedance (K $\Omega$ ) <Min.> <REF.> (1-4),(2-3)	D.C.R. (m $\Omega$ ) <Max.> (1-4),(2-3)	Rated current (1-2)(A) ※1 (3-4) shorted
CPFC85NP-100M03	Ni-Zn	0M03	0.3(@100MHz)	20	5.0
CPFC85NP-100M10	Ni-Zn	0M10	1.0(@100MHz)	25	3.0

※ 1. Rated current: The DC current at which the temperature rise is  $\Delta t = 40^\circ\text{C}$ . ( $T_a = 20^\circ\text{C}$ ).

**◆ Specification (For EMC Common Mode Choke Use)**

Part Name	Core Material	Stamp	Inductance (1-4),(2-3) @ 100kHz	Common mode attenuation(1-4,2-3)	D.C.R. (1-2) ※2 (3-4) shorted	Isolation voltage (3-4), 1 minute
CPFC85-1M15NP	Mn-Zn	1M15	4.7mH $\pm$ 30% Within	30dB(Typ.)@100kHz 43dB(Typ.)@1MHz 34dB(Typ.)@10MHz	2.0 $\Omega$ Max. at 20 $^\circ\text{C}$	500Vrms AC

※2. D.C.R. is measured by 2 lines as series because impedance will be deteriorated when D.C.R. is measured by 1 line.