

### Applications

- Wireless Infrastructure
- CATV / SATV / MoCA
- Point to Point
- Defense & Aerospace
- Test & Measurement Equipment
- General Purpose Wireless

### Product Features

- DC – 6 GHz
- +24 dBm P1dB at 1 GHz
- +39 dBm OIP3 at 1 GHz
- 20 dB Gain at 1 GHz
- 3.6 dB Noise Figure
- Internally Matched to 50  $\Omega$
- Lead-free / green / RoHS-Compliant SOT-89 Package

### General Description

The ECG003B-G is a general-purpose buffer amplifier that offers high dynamic range in a low-cost surface-mount package. At 1000 MHz, the ECG003B-G typically provides 20 dB of gain, +39 dBm Output IP3, and +24 dBm P1dB.

The ECG003B-G consists of Darlington pair amplifiers using the high reliability InGaP/GaAs HBT process technology and only requires DC-blocking capacitors, a bias resistor, and an inductive RF choke for operation. The device is ideal for wireless applications and is available in a low-cost, surface-mount lead-free/green/RoHS-compliant SOT-89 package. All devices are 100% RF and DC tested.

This broadband MMIC amplifier can be directly applied to various current and next generation wireless technologies. In addition, the ECG003B-G will satisfy general amplification requirements in the DC to 6 GHz frequency range such as CATV and mobile wireless.



SOT-89 Package Style

### Functional Block Diagram

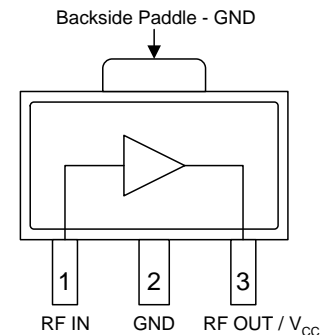

### Pin Configuration

Pin No.	Label
1	RF IN
2	GND
3	RF OUT / V <sub>CC</sub>
Backside Paddle	GND

### Ordering Information

Part No.	Description
ECG003B-G	InGaP HBT Gain Block
ECG003B-PCB	500 – 6000 MHz Evaluation Board

Standard T/R size = 1000 pieces on a 7" reel

### Absolute Maximum Ratings

Parameter	Rating
Storage Temperature	-65 to 150 °C
RF Input Power (Continuous)	+10 dBm
Device Current (I <sub>D</sub> )	160 mA

Operation of this device outside the parameter ranges given above may cause permanent damage.

### Recommended Operating Conditions

Parameter	Min	Typ	Max	Units
T <sub>CASE</sub>	-40		+85	°C
Junction Temperature			+160	°C

Electrical specifications are measured at specified test conditions. Specifications are not guaranteed over all recommended operating conditions.

### Electrical Specifications

Test conditions unless otherwise noted: V<sub>SUPPLY</sub> = +9 V, R<sub>BIAS</sub> = 16 Ω, 50 Ω System

Parameter	Conditions	Min	Typ	Max	Units
Operational Bandwidth		DC		6000	MHz
Gain	Freq.=1000 MHz OIP3 Pout=+11 dBm / Tone, Δf= 1 MHz		20		dB
Output P1dB			+24		dBm
Output IP3			+39		dBm
Noise Figure			3.5		dB
Gain	Freq.=2000 MHz OIP3 Pout=+11 dBm / Tone, Δf= 1 MHz	18	19		dB
Input Return Loss			15		dB
Output Return Loss			10		dB
Output P1dB			+23		dBm
Output IP3		+34	+36		dBm
Noise Figure			3.6		dB
Device Voltage		+6.7	+7.2	+7.6	V
Device Current			110		mA
Output Mismatch w/o Spurs			10:1		VSWR
Thermal Resistance			86		°C / W

### Typical Device RF Performance<sup>(1)</sup>

Test conditions unless otherwise noted: V<sub>SUPPLY</sub> = +9 V, R<sub>BIAS</sub> = 16 Ω, I<sub>CC</sub> = 110 mA (typ.), 50 Ω System

Parameter	Typical								Units
Frequency	100	500	900	1900	2140	2400	3500	5800	MHz
Gain	21	21	20.4	19	18.7	18.2	17.4	14	dB
Input Return Loss	20	19	18	16	15	13	12	6	dB
Output Return Loss	15	14	13	10	10	8	7	3	dB
Output P1dB	+24.4	+24.4	+24	+23	+22.5	+20.5	+18.7	+12	dBm
Output IP3 <sup>(2)</sup>	+38	+39	+39	+36	+35	+34	+31		dBm
Noise Figure	3.9	3.6	3.5	3.6	3.7	3.7	4.2		dB

Notes:

- Gain and return loss values presented above, and in the plots of the following section, are measured at the device level. Application specific performance values will differ in accordance with external components selected for the desired frequency band of operation. P1dB, OIP3 and NF data is measured using the application circuit shown on page 4.
- Pout= +11 dBm / tone, 1 MHz tone spacing.

### Typical Device RF Performance

Test conditions unless otherwise noted:  $V_{SUPPLY} = +9\text{ V}$ ,  $R_{BIAS} = 16\ \Omega$ ,  $I_{CC} = 110\text{ mA}$  (typ.),  $50\ \Omega$  System

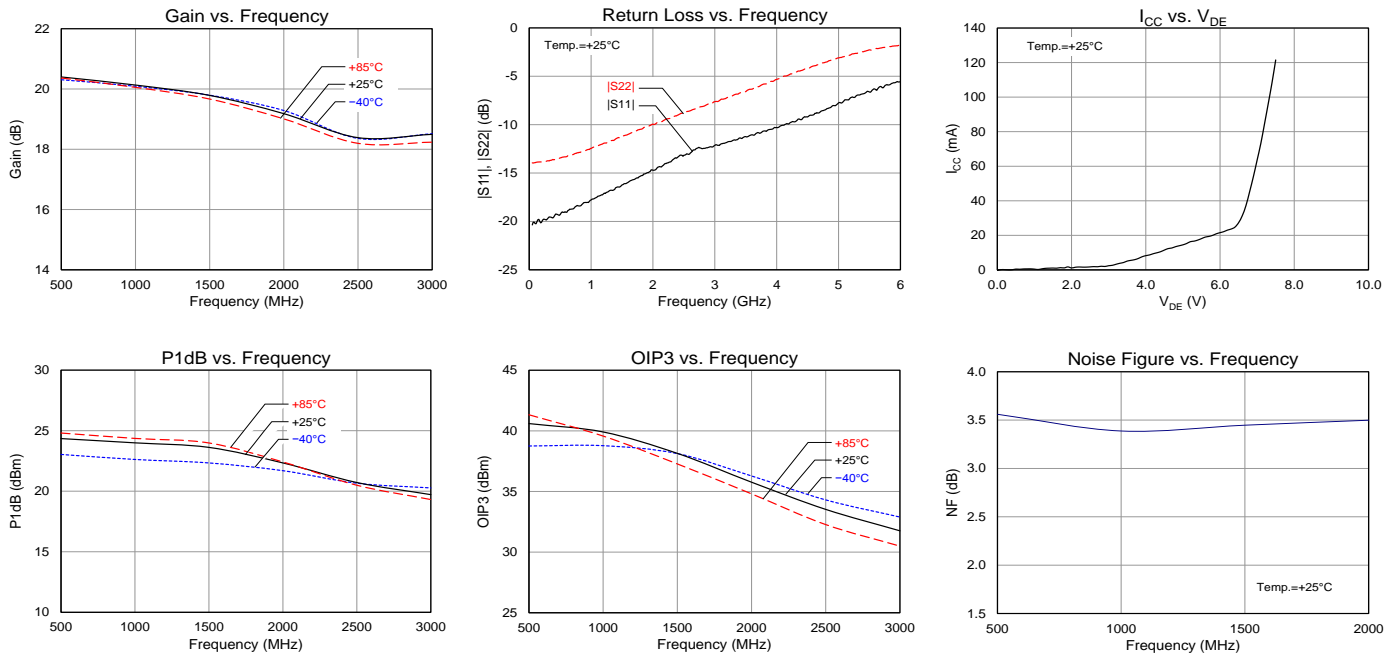

### S-Parameters

Test Conditions:  $V_{DEVICE} = +7.2\text{ V}$ ,  $I_{CC} = 110\text{ mA}$ ,  $T = 25\ ^\circ\text{C}$ , Calibrated to device leads

Freq (MHz)	S11 (dB)	S11 (ang)	S21 (dB)	S21 (ang)	S12 (dB)	S12 (ang)	S22 (dB)	S22 (ang)
50	-20.36	-0.18	20.46	177.69	-23.19	-0.38	-13.95	-2.86
500	-19.29	-24.13	20.19	157.68	-23.08	-2.33	-13.44	-35.26
1000	-17.78	-51.50	19.84	136.88	-22.93	-4.52	-12.45	-68.47
1500	-16.23	-75.63	19.40	117.06	-22.61	-7.13	-11.26	-97.26
2000	-14.71	-98.28	19.06	97.71	-22.16	-9.76	-9.96	-123.04
2500	-13.16	-118.71	18.65	78.13	-21.61	-13.40	-8.82	-145.90
3000	-12.14	-139.91	18.23	59.26	-20.91	-17.67	-7.63	-167.85
3500	-11.24	-161.53	17.77	40.27	-20.11	-23.92	-6.59	171.00
4000	-10.30	174.59	17.32	20.70	-19.35	-31.44	-5.32	150.44
4500	-9.20	147.71	16.71	0.41	-18.62	-41.28	-4.19	128.81
5000	-7.76	120.30	15.97	-19.87	-18.16	-52.98	-3.10	107.78
5500	-6.63	92.76	14.85	-40.81	-18.05	-66.03	-2.28	87.09
6000	-5.54	70.28	13.49	-59.45	-18.34	-79.15	-1.78	67.70

Notes:

1. Device S-parameters are available for download off of the website at: [www.triquint.com](http://www.triquint.com)

## ECG003B-PCB Evaluation Board

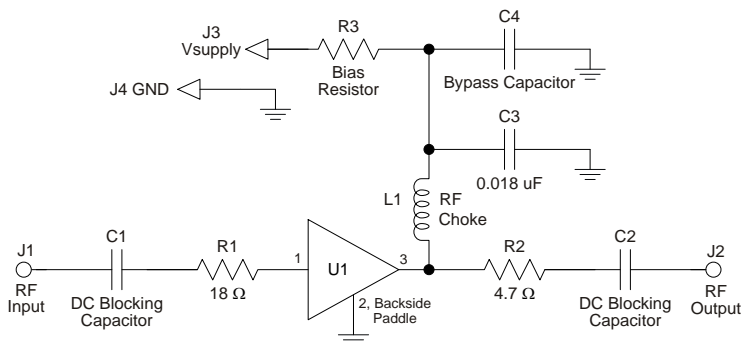
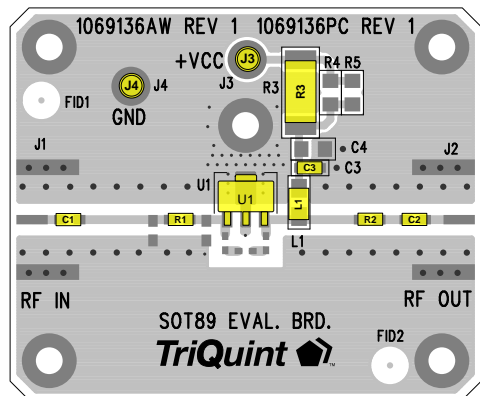

Notes:

1. See Evaluation Board PCB Information section for material and stack-up.

### Bill of Material: ECG003B-PCB

Ref. Des.	Value	Description
U1	n/a	ECG003B-G
L1	39 nH	Wirewound Inductor, 0603
C1, C2	56 pF	Chip Capacitor, 0603
C3	0.018 μF	Chip Capacitor, 0603
C4	Do Not Place	
R1	18 Ω	Chip Resistor, 0603
R2	4.7 Ω	Chip Resistor, 0603
R3	16 Ω	1% Tolerance, 2010

### R<sub>BIAS</sub> Values for Various V<sub>SUPPLY</sub>

V <sub>SUPPLY</sub> (V <sub>CC</sub> )	9	10	12
R3 (Ω)	16	25	44
Component Size	2010	2512	2512

### Component Values for Specific Frequencies

Frequency (MHz)	50	500	900	1900	2200	2500	3500
L1	820 nH	220 nH	68 nH	27 nH	22 nH	18 nH	15 nH
C1, C2, C3	.018 μF	1000 pF	100 pF	68 pF	68 pF	56 pF	39 pF

### Performance Plots – ECG003B-PCB

Test conditions unless otherwise noted: V<sub>SUPPLY</sub> = +9 V, R<sub>BIAS</sub> = 16 Ω, I<sub>CC</sub> = 110 mA (typ.), 50 Ω System

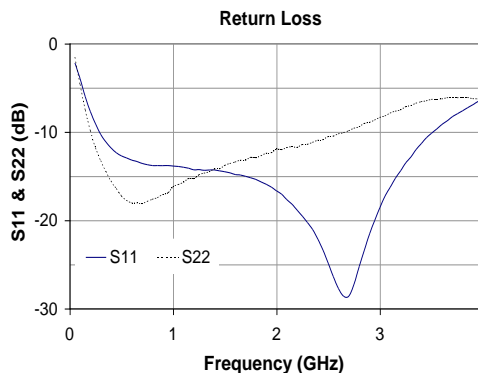
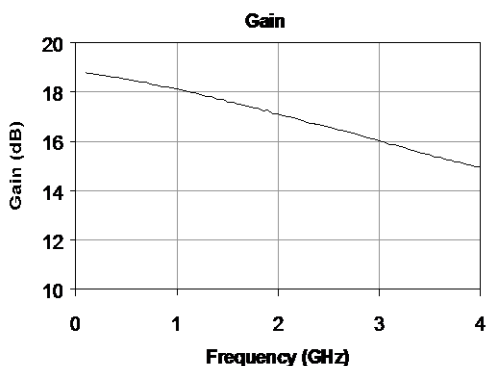

## Pin Configuration and Description

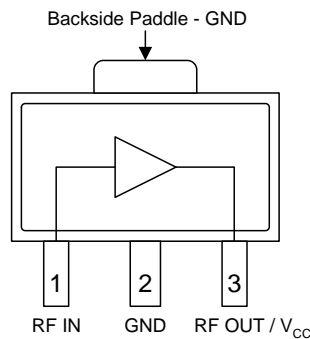

Pin No.	Label	Description
1	RF IN	RF input, matched to 50 ohms. External DC Block is required.
3	RF OUT / V <sub>CC</sub>	RF output / DC supply, matched to 50 ohms. External DC Block, bias choke, and dropping resistor is required.
2, Backside Paddle	GND Paddle	RF/DC ground. Use recommended via pattern to minimize inductance and thermal resistance. See PCB Mounting Pattern for suggested footprint.

## Evaluation Board PCB Information

### TriQuint PCB 1069136 Material and Stack-up

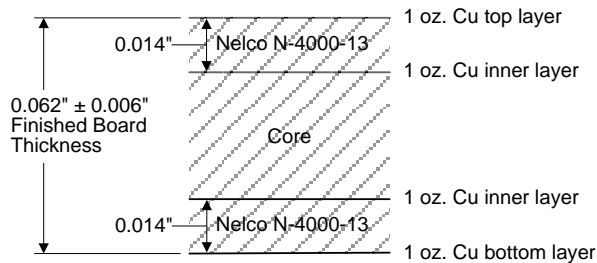

50 Ohm Line Dimensions: Width=0.028"  
Spacing=0.036"

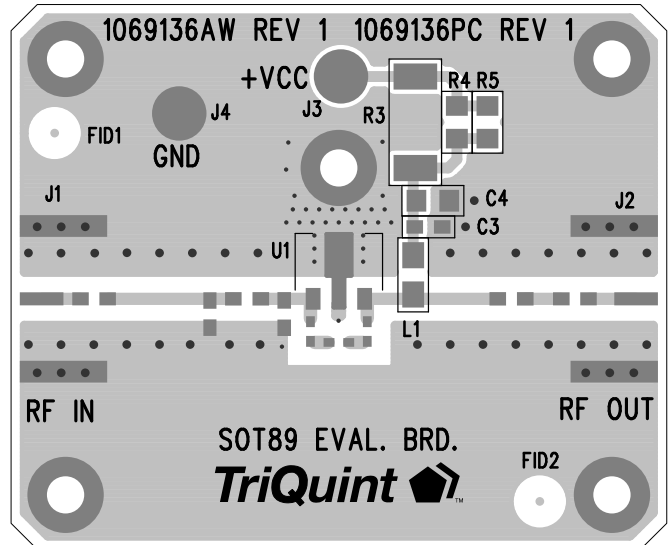

## Package Marking and Dimensions

Marking: Product Identifier – E003G  
 Lot Code – YXXX

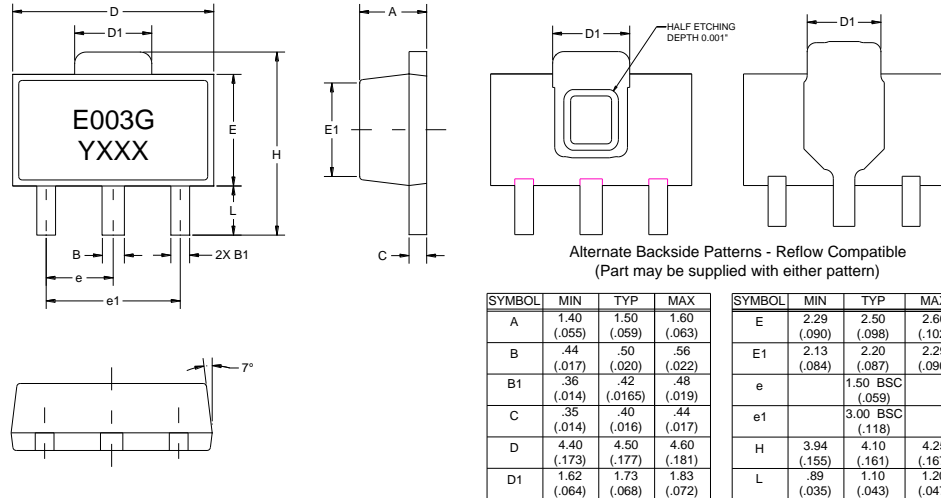

**Notes:**

1. All dimensions are in millimeters. Angles are in degrees.
2. Dimension and tolerance formats conform to ASME Y14.4M-1994.
3. The terminal #1 identifier and terminal numbering conform to JESD 95-1 SPP-012.
4. Contact plating: NiPdAu

## PCB Mounting Pattern

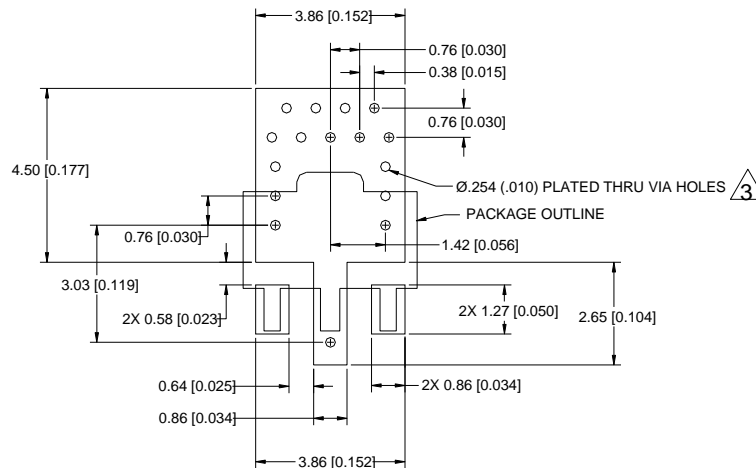

**Notes:**

1. All dimensions are in millimeters. Angles are in degrees.
2. Use 1 oz. copper minimum for top and bottom layer metal.
3. Vias are required under the backside paddle of this device for proper RF/DC grounding and thermal dissipation.
4. Do not remove or minimize via hole structure in the PCB. Thermal and RF grounding is critical.
5. We recommend a 0.35mm (#80/.0135") diameter bit for drilling via holes and a final plated thru diameter of 0.25 mm (0.10").
6. Ensure good package backside paddle solder attach for reliable operation and best electrical performance.

## Product Compliance Information

### ESD Sensitivity Ratings



Caution! ESD-Sensitive Device

ESD Rating: Class 1A  
Value:  $\geq 250$  V to  $< 500$  V  
Test: Human Body Model (HBM)  
Standard: ESDA/JEDEC Standard JS-001-2012

### MSL Rating

MSL Rating: Level 3  
Test: 260 °C convection reflow  
Standard: JEDEC Standard IPC/JEDEC J-STD-020

### Solderability

Compatible with both lead-free (260 °C maximum reflow temperature) and tin/lead (245 °C maximum reflow temperature) soldering processes.

Contact plating: NiPdAu

### RoHS Compliance

This part is compliant with EU 2002/95/EC RoHS directive (Restrictions on the Use of Certain Hazardous Substances in Electrical and Electronic Equipment).

This product also has the following attributes:

- Lead Free
- Halogen Free (Chlorine, Bromine)
- Antimony Free
- TBBP-A (C<sub>15</sub>H<sub>12</sub>Br<sub>4</sub>O<sub>2</sub>) Free
- PFOS Free
- SVHC Free

## Contact Information

For the latest specifications, additional product information, worldwide sales and distribution locations, and information about TriQuint:

**Web:** [www.triquint.com](http://www.triquint.com)      **Tel:** +1.503.615.9000  
**Email:** [info-sales@triquint.com](mailto:info-sales@triquint.com)      **Fax:** +1.503.615.8902

For technical questions and application information:

**Email:** [sjcapplcations.engineering@triquint.com](mailto:sjcapplcations.engineering@triquint.com)

## Important Notice

The information contained herein is believed to be reliable. TriQuint makes no warranties regarding the information contained herein. TriQuint assumes no responsibility or liability whatsoever for any of the information contained herein. TriQuint assumes no responsibility or liability whatsoever for the use of the information contained herein. The information contained herein is provided "AS IS, WHERE IS" and with all faults, and the entire risk associated with such information is entirely with the user. All information contained herein is subject to change without notice. Customers should obtain and verify the latest relevant information before placing orders for TriQuint products. The information contained herein or any use of such information does not grant, explicitly or implicitly, to any party any patent rights, licenses, or any other intellectual property rights, whether with regard to such information itself or anything described by such information.

TriQuint products are not warranted or authorized for use as critical components in medical, life-saving, or life-sustaining applications, or other applications where a failure would reasonably be expected to cause severe personal injury or death.