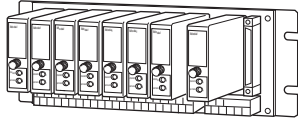

Super-mini Signal Conditioners Mini-M Series**INSTALLATION BASE (8 positions)****Functions & Features**

- Receiving at the maximum of 8 modules of Mini-M series signal conditioners
- Connector output
- Power supplied through printed wiring on the base

**MODEL: M2BS-8[1][2]****ORDERING INFORMATION**

- Code number: M2BS-8[1][2]
- Specify a code from below for each of [1] and [2].
(e.g. M2BS-8U2/D/UL)

[1] FUNCTION

- U1:** Fujitsu FCN type I/O connector (UL not available)
U2: Omron I/O connector

[2] OPTIONS (multiple selections)**Mounting**

- blank:** Surface
/D: DIN rail mounting adaptor

Standards & Approvals

- blank:** Without UL
/UL: UL approval

RELATED PRODUCTS

- Connector terminal block (model: CNT)
- Special cable with 40-pin connector (model: FCN)

GENERAL SPECIFICATIONS

- Capacity:** 8 positions
Connection
Power input: M3 screw terminals (torque 0.8 N·m)
Input and output: M3 screw terminals (torque 0.8 N·m)
Screw terminal: Nickel-plated steel

INSTALLATION

- Power input:** Refer to signal conditioner data sheet. Choose the same power input specification for all units.
Operating temperature: -5 to +55°C (23 to 131°F)
Operating humidity: 30 to 90 %RH (non-condensing)
Mounting: wall; optional DIN rail mounting available (in horizontal direction only)
Weight: 780 g (1.72 lb)

PERFORMANCE

- Insulation resistance:** $\geq 100 \text{ M}\Omega$ with 500 V DC (input to output to power to FG)
Dielectric strength: 2000 V AC @1 minute (input to output to power to FG)

STANDARDS & APPROVALS**EU conformity:**

- EMC Directive
EMI EN 61000-6-4
EMS EN 61000-6-2
Low Voltage Directive
EN 61010-1
Installation Category II
Pollution Degree 2
Input or output to power: Reinforced insulation (300 V)
Input to output: Basic insulation (300 V)
RoHS Directive
EN 50581

Approval:

- UL/C-UL nonincendive Class I, Division 2, Groups A, B, C, and D
(ANSI/ISA-12.12.01, CAN/CSA-C22.2 No.213)
UL/C-UL general safety requirements
(UL 3111-1, CAN/CSA-C22.2 No.1010-1)
Voltage at the field I/O terminals (except power input terminals) limited within 30 V DC for UL.

CONNECTION DIAGRAM

■ MODEL: M2BS-8U1 (Fujitsu FCN type I/O connector FCN364P040-AU)

- Connector Pin Assignment

CN1: output

PIN NO.	ASSIGNMENT	PIN NO.	ASSIGNMENT
A1	ch.1 +	B1	ch.1 -
A2	ch.2 +	B2	ch.2 -
A3	ch.3 +	B3	ch.3 -
A4	ch.4 +	B4	ch.4 -
A5	ch.5 +	B5	ch.5 -
A6	ch.6 +	B6	ch.6 -
A7	ch.7 +	B7	ch.7 -
A8	ch.8 +	B8	ch.8 -

A9 – A20, B9 – B20: Unused

■ CONNECTION DIAGRAM

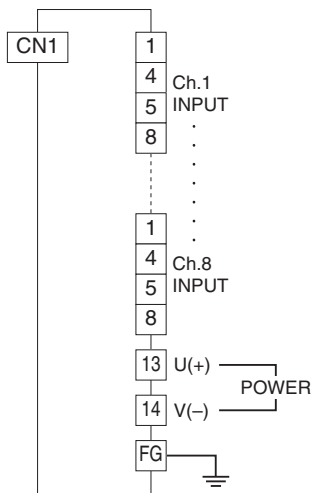

■ MODEL: M2BS-8U2 (Omron I/O connector XG4A-3431)

- Connector Pin Assignment

CN1: output

PIN NO.	ASSIGNMENT	PIN NO.	ASSIGNMENT
1	ch.1 +	2	ch.1 -
3	ch.2 +	4	ch.2 -
5	ch.3 +	6	ch.3 -
7	ch.4 +	8	ch.4 -
9	ch.5 +	10	ch.5 -
11	ch.6 +	12	ch.6 -
13	ch.7 +	14	ch.7 -
15	ch.8 +	16	ch.8 -

17 – 34: Unused

■ CONNECTION DIAGRAM

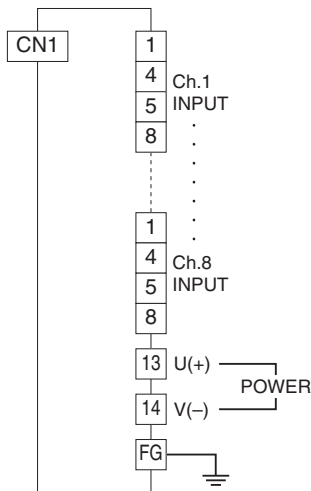

EXTERNAL DIMENSIONS & TERMINAL ASSIGNMENTS unit: mm (inch)

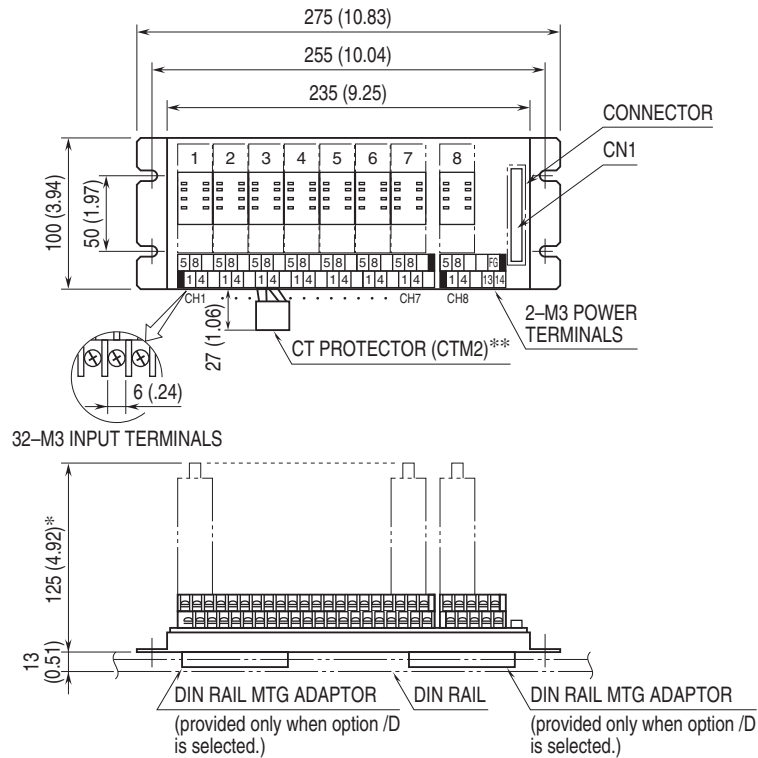

*165 (6.50) required for pneumatic tubing for M2PV.

**Attached to M2CA and M2CE.

MOUNTING REQUIREMENTS unit: mm (inch)

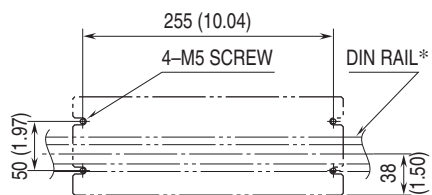

*Installed in horizontal direction only.



Specifications are subject to change without notice.