

## bq2408x-Q1 1-A, Single Chip, Li-Ion and Li-Pol Automotive Charger

### 1 Features

- Integrated Power FET and Current Sensor for Up to 1-A Charge Applications From AC Adapter
- Precharge Conditioning With Safety Timer
- Charge and Power-Good Status Output
- Automatic Sleep Mode for Low Power Consumption
- Integrated Charge-Current Monitor
- Fixed 7-Hour Fast Charge Safety Timer
- Ideal for Low-Dropout Charger Designs for Single-Cell Li-Ion or Li-Pol Packs in Space-Limited Portable Applications
- Small 3-mm x 3-mm SON Package

### 2 Applications

- Linear Chargers for Automotive
- E-Call/ Back Up Call battery
- Automotive Infotainment
- Key FOB in Automotive

### 3 Description

The bq24080-Q1 and bq24081-Q1 are highly integrated and flexible Li-Ion linear charge devices targeted at space-limited charger applications. They offer an integrated power FET and current sensor, high-accuracy current and voltage regulation, charge status, and charge termination, in a single monolithic device. An external resistor sets the magnitude of the charge current.

The device charges the battery in three phases: conditioning, constant current, and constant voltage. Charge is terminated based on minimum current. An internal charge timer provides a backup safety for charge termination. The device automatically restarts the charge if the battery voltage falls below an internal threshold. The device automatically enters sleep mode when the ac adapter is removed.

#### Device Information<sup>(1)</sup>

PART NUMBER	PACKAGE	BODY SIZE (NOM)
bq24080-Q1 <sup>(2)</sup>	VSON (10)	3.00 mm x 3.00 mm
bq24081-Q1		

(1) For all available packages, see the orderable addendum at the end of the datasheet.

(2) Product Preview

### 4 Simplified Schematic

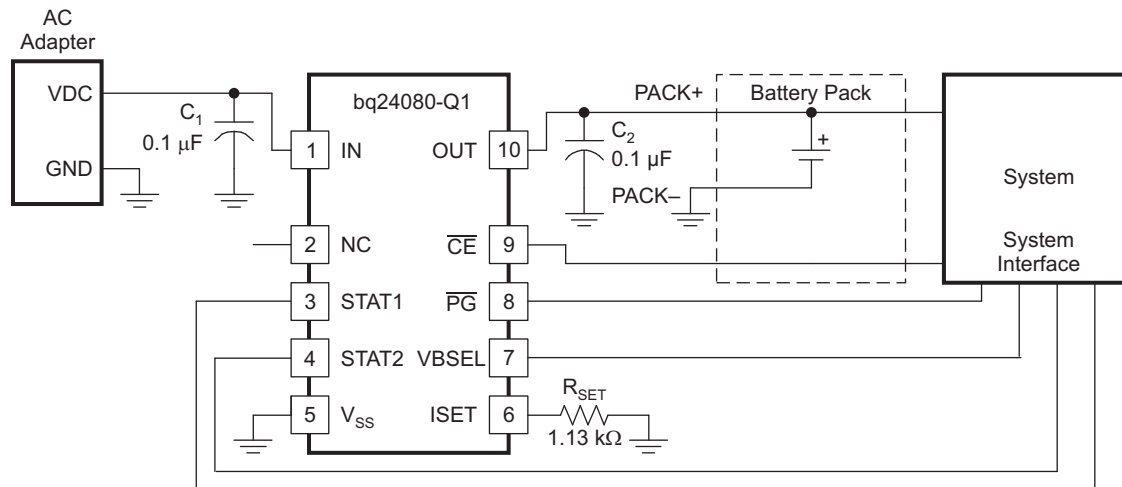

## Table of Contents

<b>1 Features</b> .....	<b>1</b>	8.4 Device Functional Modes.....	<b>14</b>
<b>2 Applications</b> .....	<b>1</b>	<b>9 Application and Implementation</b> .....	<b>15</b>
<b>3 Description</b> .....	<b>1</b>	9.1 Application Information.....	<b>15</b>
<b>4 Simplified Schematic</b> .....	<b>1</b>	9.2 Typical Application .....	<b>15</b>
<b>5 Revision History</b> .....	<b>2</b>	<b>10 Power Supply Recommendations</b> .....	<b>17</b>
<b>6 Pin Configuration and Functions</b> .....	<b>3</b>	<b>11 Layout</b> .....	<b>18</b>
<b>7 Specifications</b> .....	<b>4</b>	11.1 Layout Guidelines .....	<b>18</b>
7.1 Absolute Maximum Ratings .....	<b>4</b>	11.2 Layout Example .....	<b>18</b>
7.2 ESD Ratings.....	<b>4</b>	11.3 Thermal Considerations .....	<b>19</b>
7.3 Recommended Operating Conditions .....	<b>4</b>	<b>12 Device and Documentation Support</b> .....	<b>20</b>
7.4 Thermal Information .....	<b>4</b>	12.1 Device Support.....	<b>20</b>
7.5 Electrical Characteristics.....	<b>5</b>	12.2 Documentation Support .....	<b>20</b>
7.6 Timing Requirements .....	<b>6</b>	12.3 Related Links .....	<b>20</b>
7.7 Typical Characteristics .....	<b>7</b>	12.4 Community Resources.....	<b>20</b>
<b>8 Detailed Description</b> .....	<b>8</b>	12.5 Trademarks .....	<b>20</b>
8.1 Overview .....	<b>8</b>	12.6 Electrostatic Discharge Caution.....	<b>20</b>
8.2 Functional Block Diagram .....	<b>10</b>	12.7 Glossary .....	<b>20</b>
8.3 Feature Description.....	<b>11</b>	<b>13 Mechanical, Packaging, and Orderable Information</b> .....	<b>20</b>

## 5 Revision History

DATE	REVISION	NOTES
May 2015	*	Initial release.

## 6 Pin Configuration and Functions

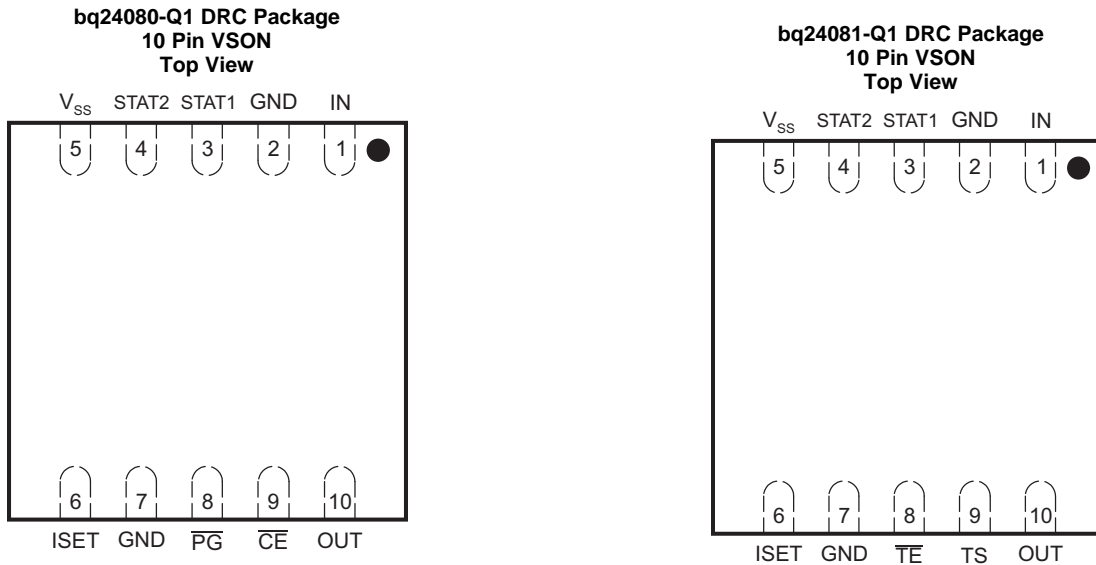

### Pin Functions

NAME	PIN		I/O	DESCRIPTION
	NO.			
	bq24080-Q1	bq24081-Q1		
$\overline{\text{CE}}$	9	–	I	Charge enable input (active-low)
GND	2, 7	2, 7	–	Ground
IN	1	1	I	Adapter dc voltage. Connect minimum 0.1- $\mu\text{F}$ capacitor to $V_{\text{SS}}$ .
ISET	6	6	I	Charge current. External resistor to $V_{\text{SS}}$ sets precharge and fast-charge current, and also the termination current value. Can be used to monitor the charge current.
OUT	10	10	O	Charge current output. Connect minimum 0.1- $\mu\text{F}$ capacitor to $V_{\text{SS}}$ .
$\overline{\text{PG}}$	8	–	O	Power-good status output (open-drain)
STAT1	3	3	O	Charge status outputs (open-drain)
STAT2	4	4	O	
$\overline{\text{TE}}$	–	8	I	Timer-enable input (active-low)
TS	–	9	I/O	Temperature sense; connect to NTC in battery pack.
$V_{\text{SS}}$	5	5	–	Ground
Thermal pad	–	–	–	There is an internal electrical connection between the exposed thermal pad and the VSS pin of the device. The exposed thermal pad must be connected to the same potential as the $V_{\text{SS}}$ pin on the printed-circuit board. <b>Do not use the thermal pad as the primary ground input for the device.</b> The $V_{\text{SS}}$ pin must be connected to ground at all times.

## 7 Specifications

### 7.1 Absolute Maximum Ratings

over operating free-air temperature range (unless otherwise noted)<sup>(1)</sup>

		bq24080-Q1, bq24081-Q1		UNIT
		MIN	MAX	
Input voltage <sup>(2)</sup>	IN, $\overline{CE}$ , ISET, OUT, $\overline{PG}$ , STAT1, STAT2, $\overline{TE}$ , TS	-0.3	7	V
Output sink/source current	STAT1, STAT2, $\overline{PG}$		15	mA
Output current	OUT		1.5	A
Operating free-air temperature range, T <sub>A</sub>		-40	125	°C
Junction temperature range, T <sub>J</sub>				°C
Storage temperature, T <sub>stg</sub>		-65	150	°C

(1) Stresses beyond those listed under *Absolute Maximum Ratings* may cause permanent damage to the device. These are stress ratings only, which do not imply functional operation of the device at these or any other conditions beyond those indicated under *Recommended Operating Conditions*. Exposure to absolute-maximum-rated conditions for extended periods may affect device reliability.

(2) All voltages are with respect to V<sub>SS</sub>.

### 7.2 ESD Ratings

		VALUE	UNIT
V <sub>(ESD)</sub>	Electrostatic discharge	Human-body model (HBM), per AEC Q100-002 <sup>(1)</sup>	±2000
		Charged-device model (CDM), per AEC Q100-011	±500
			V

(1) AEC Q100-002 indicates that HBM stressing shall be in accordance with the ANSI/ESDA/JEDEC JS-001 specification.

### 7.3 Recommended Operating Conditions

over operating free-air temperature range (unless otherwise noted)

		MIN	MAX	UNIT
V <sub>CC</sub>	Supply voltage	4.5	6.5	V
T <sub>J</sub>	Operating junction temperature range	0	125	°C

### 7.4 Thermal Information

THERMAL METRIC <sup>(1)</sup>		bq24080-Q1, bq24081-Q1		UNIT
		DRC		
		10 PINS		
R <sub>θJA</sub>	Junction-to-ambient thermal resistance	44.3		°C/W
R <sub>θJC(top)</sub>	Junction-to-case (top) thermal resistance	5034		°C/W
R <sub>θJB</sub>	Junction-to-board thermal resistance	19.7		°C/W
Ψ <sub>JT</sub>	Junction-to-top characterization parameter	0.7		°C/W
Ψ <sub>JB</sub>	Junction-to-board characterization parameter	19.9		°C/W
R <sub>θJC(bot)</sub>	Junction-to-case (bottom) thermal resistance	4.5		°C/W

(1) For more information about traditional and new thermal metrics, see the *Semiconductor and IC Package Thermal Metrics* application report, [SPRA953](#).

## 7.5 Electrical Characteristics

over  $0^{\circ}\text{C} \leq T_J \leq 125^{\circ}\text{C}$  and recommended supply voltage (unless otherwise noted)

PARAMETER		TEST CONDITIONS	MIN	TYP	MAX	UNIT
<b>INPUT CURRENT</b>						
$I_{CC(VCC)}$	$V_{CC}$ current	$V_{CC} > V_{CC(\text{min})}$		1.2	2	mA
$I_{CC(\text{SLP})}$	Sleep current	Sum of currents into OUT pin, $V_{CC} < V_{(\text{SLP})}$		2	5	$\mu\text{A}$
$I_{CC(\text{STBY})}$	Standby current	$\overline{\text{CE}} = \text{High}$ , $0^{\circ}\text{C} \leq T_J \leq 85^{\circ}\text{C}$			150	
$I_{\text{IB(OUT)}}$	Input current on OUT pin	Charge DONE, $V_{CC} > V_{CC(\text{MIN})}$		1	5	
<b>VOLTAGE REGULATION</b> $V_{O(\text{REG})} + V_{(\text{DO-MAX})} \leq V_{CC}$ , $I_{(\text{TERM})} < I_{O(\text{OUT})} \leq 1 \text{ A}$						
$V_{O(\text{REG})}$	Output voltage			4.2		V
	Voltage regulation accuracy	$T_A = 25^{\circ}\text{C}$	-0.35%		0.35%	
			-1%		1%	
$V_{(\text{DO})}$	Dropout voltage ( $V_{(\text{IN})} - V_{(\text{OUT})}$ )	$V_{O(\text{OUT})} = V_{O(\text{REG})}$ , $I_{O(\text{OUT})} = 1 \text{ A}$ $V_{O(\text{REG})} + V_{(\text{DO})} \leq V_{CC}$		350	500	mV
<b>CURRENT REGULATION</b>						
$I_{O(\text{OUT})}$	Output current range <sup>(1)</sup>	$V_{\text{I(OUT)}} > V_{(\text{LOWV})}$ , $V_{\text{I(IN)}} - V_{\text{I(OUT)}} > V_{(\text{DO})}$ , $V_{CC} \geq 4.5 \text{ V}$	20		1000	mA
$V_{(\text{SET})}$	Output current set voltage	Voltage on ISET pin, $V_{CC} \geq 4.5 \text{ V}$ , $V_{\text{I}} \geq 4.5 \text{ V}$ , $V_{\text{I(OUT)}} > V_{(\text{LOWV})}$ , $V_{\text{I}} - V_{\text{I(OUT)}} > V_{(\text{DO})}$	2.463	2.5	2.538	V
$K_{(\text{SET})}$	Output current set factor	$50 \text{ mA} \leq I_{O(\text{OUT})} \leq 1 \text{ A}$	307	322	337	
		$10 \text{ mA} \leq I_{O(\text{OUT})} < 50 \text{ mA}$	296	320	346	
		$1 \text{ mA} \leq I_{O(\text{OUT})} < 10 \text{ mA}$	246	320	416	
<b>PRECHARGE AND SHORT-CIRCUIT CURRENT REGULATION</b>						
$V_{(\text{LOWV})}$	Precharge to fast-charge transition threshold	Voltage on OUT pin	2.8	3	3.2	V
$I_{O(\text{PRECHG})}$	Precharge range <sup>(2)</sup>	$0 \text{ V} < V_{\text{I(OUT)}} < V_{(\text{LOWV})}$ , $t < t_{(\text{PRECHG})}$	2		100	mA
$V_{(\text{PRECHG})}$	Precharge set voltage	Voltage on ISET pin, $V_{O(\text{REG})} = 4.2 \text{ V}$ , $0 \text{ V} < V_{\text{I(OUT)}} > V_{(\text{LOWV})}$ , $t < t_{(\text{PRECHG})}$	240	255	270	mV
<b>TERMINATION DETECTION</b>						
$I_{(\text{TERM})}$	Charge termination detection range <sup>(3)</sup>	$V_{\text{I(OUT)}} > V_{(\text{RCH})}$ , $t < t_{(\text{TRMDET})}$	2		100	mA
$V_{(\text{TERM})}$	Charge termination detection set voltage	Voltage on ISET pin, $V_{O(\text{REG})} = 4.2 \text{ V}$ , $V_{\text{I(OUT)}} > V_{(\text{RCH})}$ , $t < t_{(\text{TRMDET})}$	235	250	265	mV
<b>BATTERY RECHARGE THRESHOLD</b>						
$V_{(\text{RCH})}$	Recharge threshold		$V_{O(\text{REG})}$ -0.115	$V_{O(\text{REG})}$ -0.10	$V_{O(\text{REG})}$ -0.085	V
<b>STAT1, STAT2, and PG OUTPUTS</b>						
$V_{\text{OL}}$	Low-level output saturation voltage	$I_{\text{O}} = 5 \text{ mA}$			0.25	V
<b><math>\overline{\text{CE}}</math> and <math>\overline{\text{TE}}</math> INPUTS</b>						
$V_{\text{IL}}$	Low-level input voltage		0		0.4	V
$V_{\text{IH}}$	High-level input voltage		1.4			
$I_{\text{IL}}$	Low-level input current		-1			$\mu\text{A}$
$I_{\text{IH}}$	High-level input current				1	
<b>TIMERS</b>						
$I_{(\text{FAULT})}$	Timer fault recovery current			200		$\mu\text{A}$

(1) See Equation 2.

(2) See Equation 1.

(3) See Equation 4.

## Electrical Characteristics (continued)

 over  $0^{\circ}\text{C} \leq T_J \leq 125^{\circ}\text{C}$  and recommended supply voltage (unless otherwise noted)

PARAMETER		TEST CONDITIONS	MIN	TYP	MAX	UNIT
<b>SLEEP COMPARATOR</b>						
$V_{(SLP)}$	Sleep-mode entry threshold voltage	$2.3\text{ V} \leq V_{I(OUT)} \leq V_{O(REG)}$	$V_{CC} \leq V_{I(OUT)} + 80\text{ mV}$			V
$V_{(SLPEXIT)}$	Sleep-mode exit threshold voltage		$V_{CC} \geq V_{I(OUT)} + 190$			
<b>THERMAL SHUTDOWN THRESHOLDS</b>						
$T_{(SHTDWN)}$	Thermal trip threshold	$T_J$ increasing	165			$^{\circ}\text{C}$
	Thermal hysteresis		15			
<b>UNDERVOLTAGE LOCKOUT</b>						
$UVLO$	Undervoltage lockout	Decreasing $V_{CC}$	2.4	2.5	2.6	V
	Hysteresis		27			mV
<b>TEMPERATURE SENSE COMPARATOR (bq24081-Q1)</b>						
$V_{(TS1)}$	High-voltage threshold		2.475	2.5	2.525	V
$V_{(TS2)}$	Low-voltage threshold		0.485	0.5	0.515	
$I_{(TS)}$	TS pin current source		96	102	108	$\mu\text{A}$

## 7.6 Timing Requirements

			MIN	NOM	MAX	UNIT
<b>PRECHARGE AND SHORT-CIRCUIT CURRENT REGULATION</b>						
	Deglitch time for fast-charge to precharge transition	$V_{CC(MIN)} \geq 4.5\text{ V}$ , $t_{FALL} = 100\text{ ns}$ , 10-mV overdrive, $V_{I(OUT)}$ decreasing below threshold	250	375	500	ms
<b>TERMINATION DETECTION</b>						
$t_{TRMDET}$	Deglitch time for termination detection	$V_{CC(MIN)} \geq 4.5\text{ V}$ , $t_{FALL} = 100\text{ ns}$ charging current decreasing below 10-mV overdrive	250	375	500	ms
<b>BATTERY RECHARGE THRESHOLD</b>						
$t_{(DEGL)}$	Deglitch time for recharge detect	$V_{CC(MIN)} \geq 4.5\text{ V}$ , $t_{FALL} = 100\text{ ns}$ decreasing below or increasing above threshold, 10-mV overdrive	250	375	500	ms
<b>TIMERS</b>						
$t_{(PRECHG)}$	Precharge time		1,584	1,800	2,016	s
$t_{(CHG)}$	Charge time		22,176	25,200	28,224	s
<b>SLEEP COMPARATOR</b>						
	Sleep-mode entry deglitch time	$V_{(IN)}$ decreasing below threshold, $t_{FALL} = 100\text{ ns}$ , 10-mV overdrive	250	375	500	ms
<b>TEMPERATURE SENSE COMPARATOR (bq24081-Q1)</b>						
$t_{(DEGL)}$	Deglitch time for temperature fault		250	375	500	ms

## 7.7 Typical Characteristics

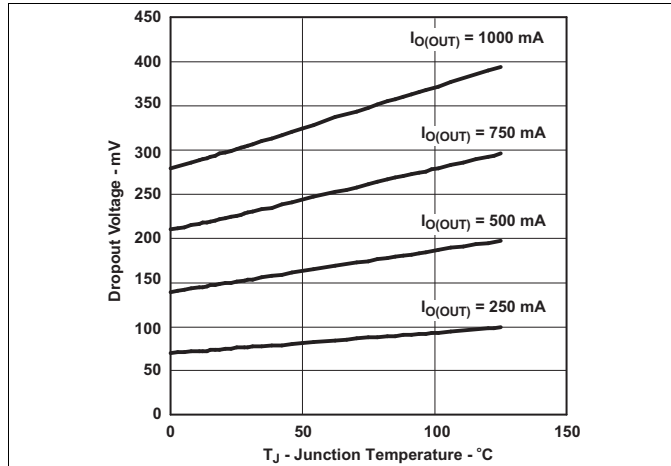

Figure 1. Dropout Voltage vs Junction Temperature

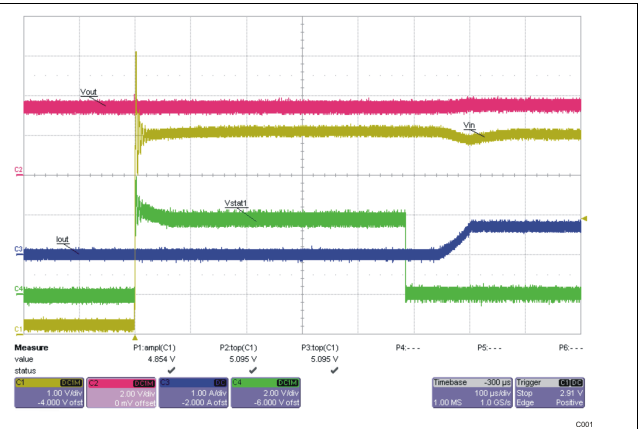

Figure 2. V<sub>IN</sub> Hot-Plug Power-Up Sequence

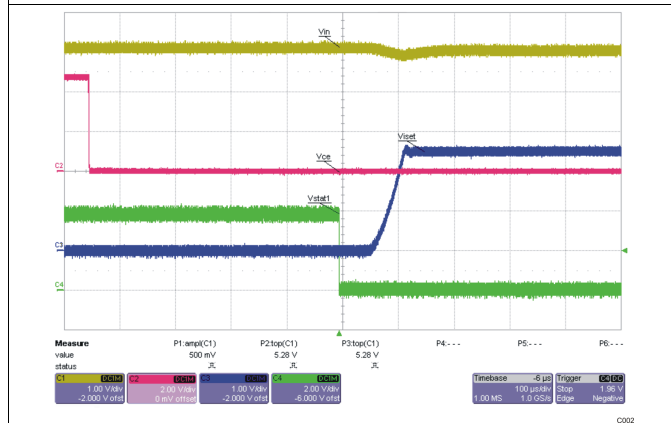

Figure 3. Charge Enable Power-Up Sequence (CE = High-to-Low)

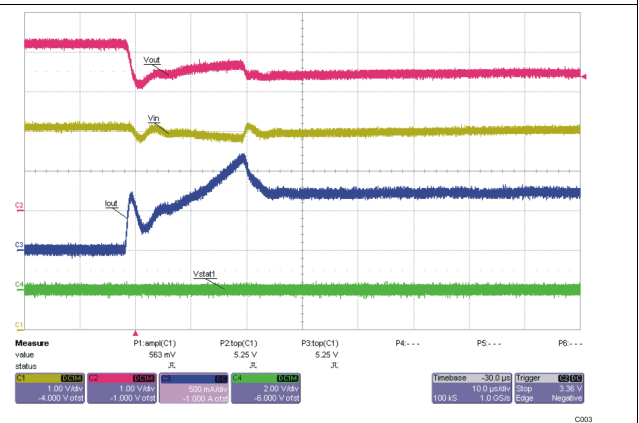
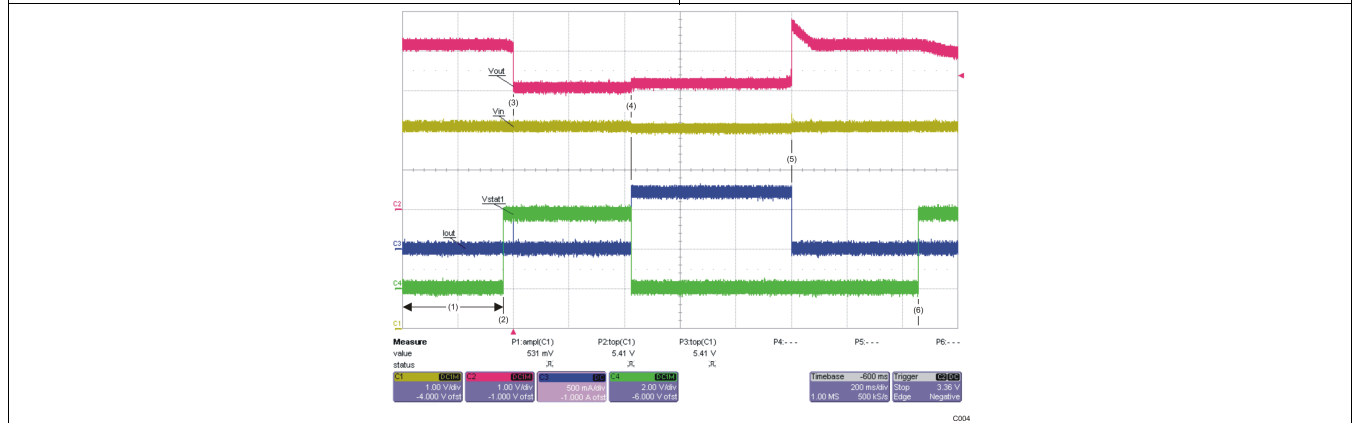

Figure 4. Battery Hot-Plug During Charging Phase



No battery – In termination deglitch prior to STAT1 going high. V<sub>OUT</sub> (V<sub>BAT</sub>) cycling between *charge* and *done* prior to screen capture  
 Stat1 goes high – In *done* state  
 2-V battery is inserted during the *charge done* state.  
 Charging is initiated – STAT1 goes low and charge current is applied.  
 Battery is removed – V<sub>OUT</sub> goes into regulation, I<sub>OUT</sub> goes to zero, and termination deglitch timer starts running (same as state 1).  
 Deglitch timer expires – *charge done* is declared.

Figure 5. Battery Hot-Plug and Removal Power Sequence

## 8 Detailed Description

### 8.1 Overview

The device supports a precision Li-Ion, Li-Pol charging system suitable for single cells. [Figure 6](#) shows a typical charge profile, and [Figure 7](#) shows an operational flow chart.

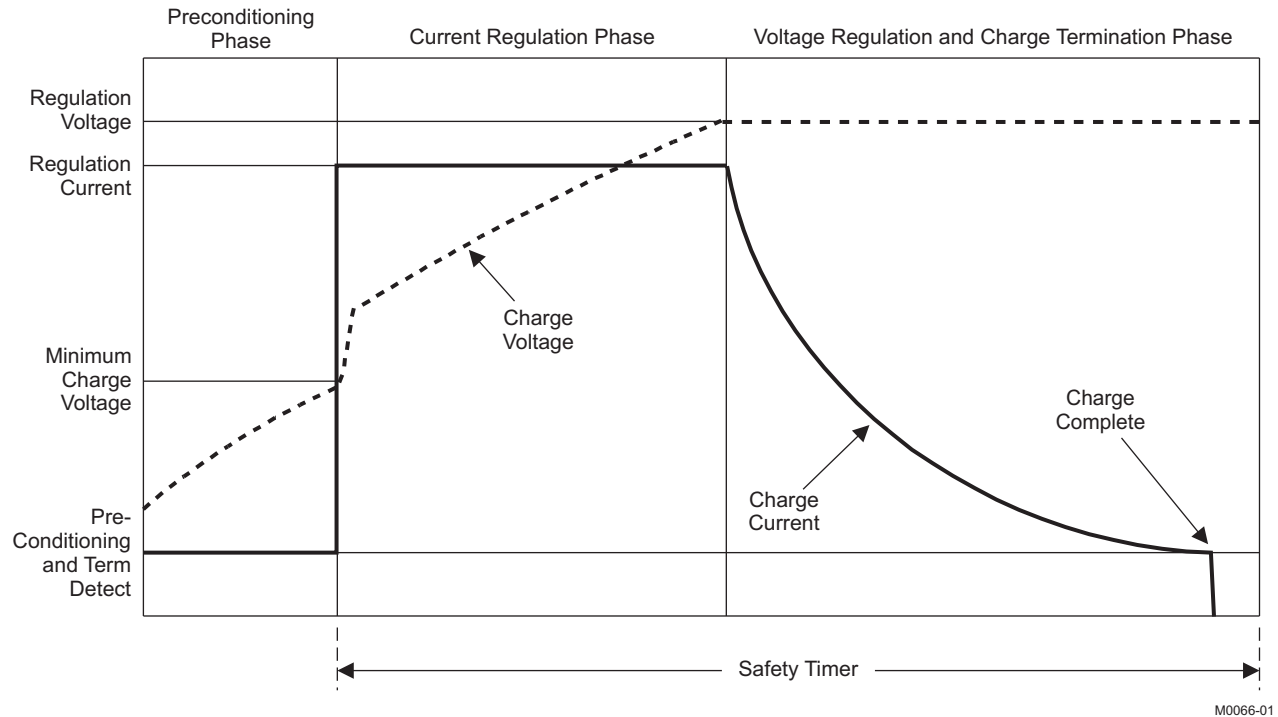

**Figure 6. Typical Charging Profile**



Overview (continued)

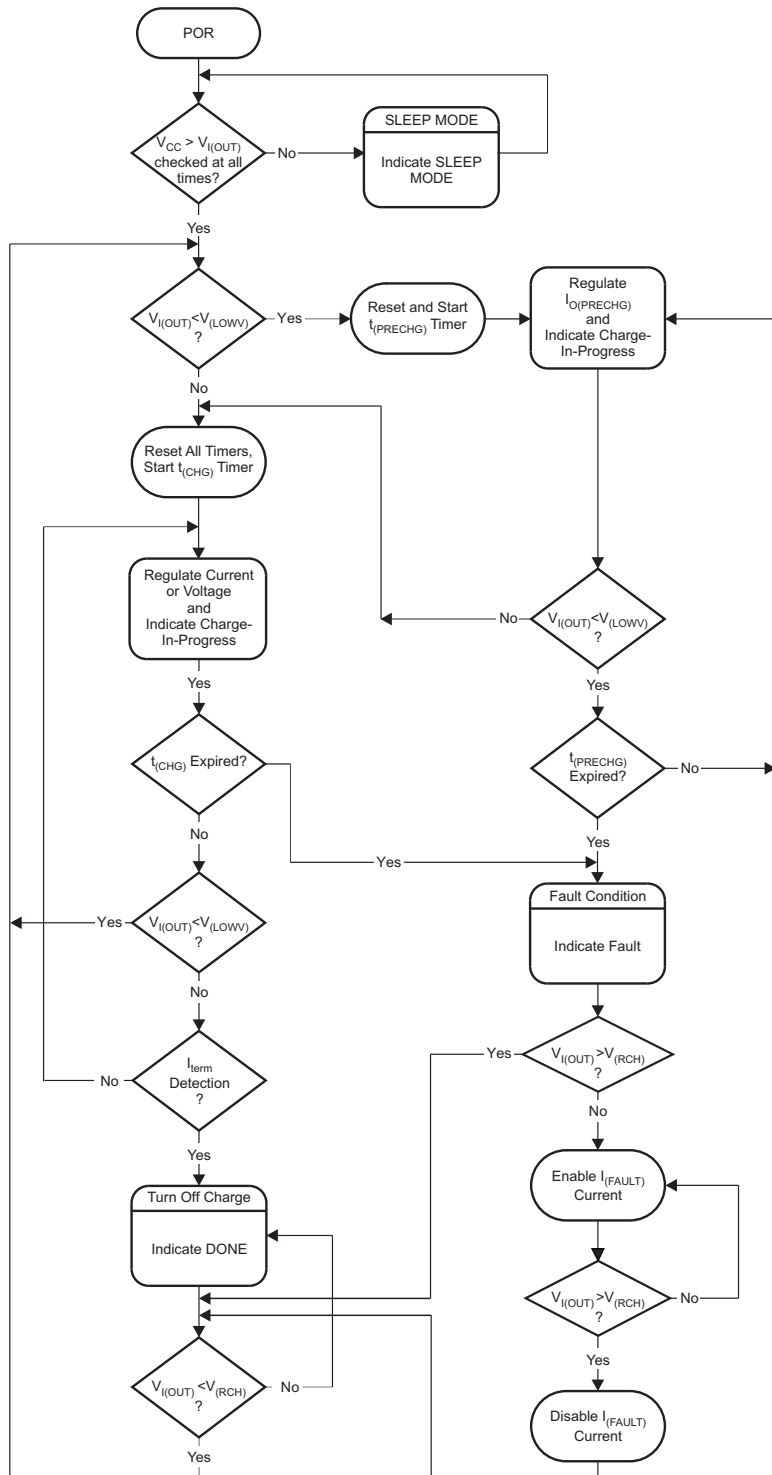

F0018-01

Figure 7. Operational Flow Chart

## 8.2 Functional Block Diagram

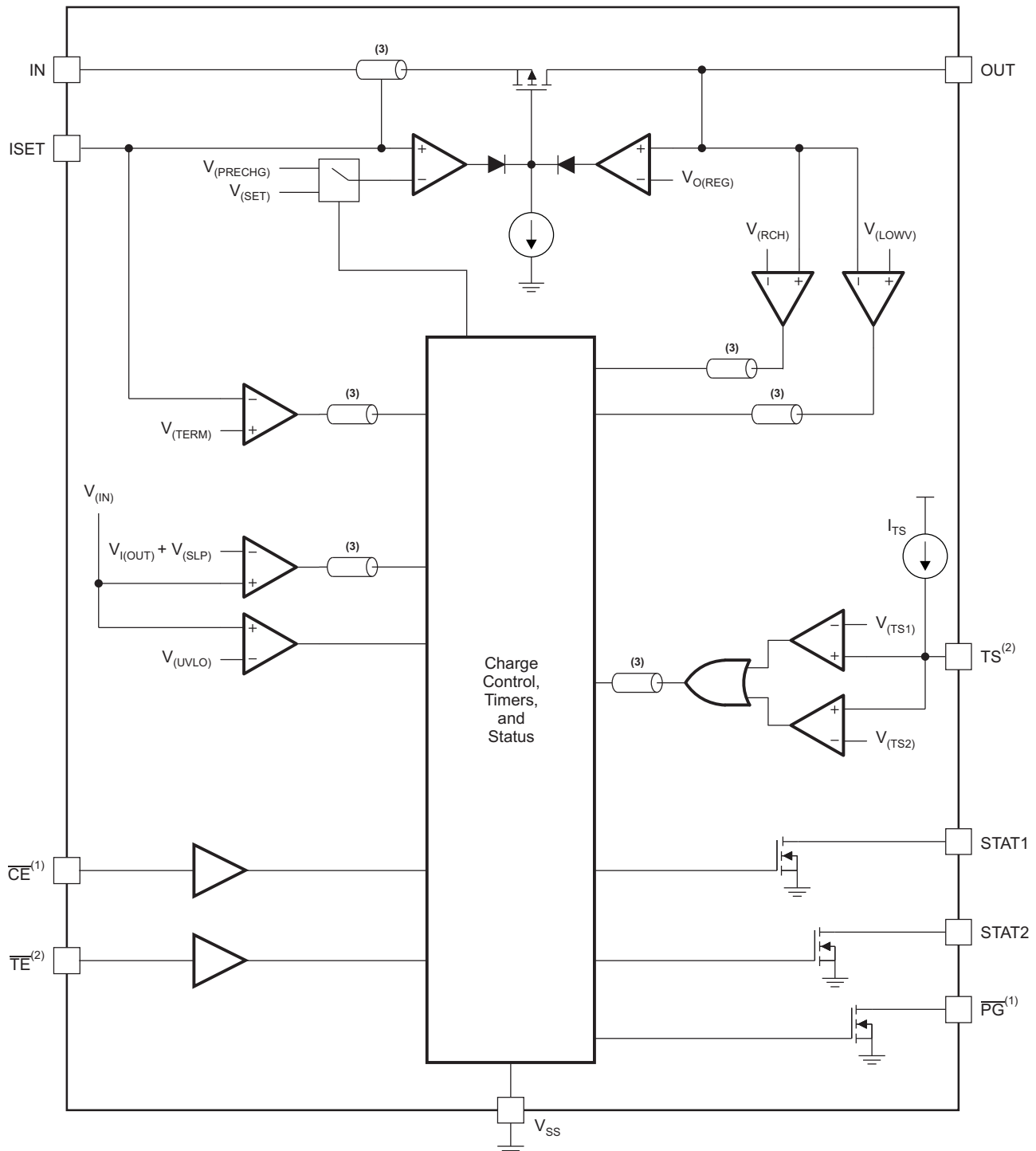

B0193-01

(1) bq24080-Q1 only

(2) bq24081-Q1 only

(3) Signal deglitched

## 8.3 Feature Description

### 8.3.1 Battery Preconditioning

During a charge cycle, if the battery voltage is below the  $V_{(LOWV)}$  threshold, the device applies a precharge current,  $I_{O(PRECHG)}$ , to the battery. This feature revives deeply discharged cells. Resistor  $R_{SET}$ , connected between the ISET and  $V_{SS}$ , determines the precharge rate. The  $V_{(PRECHG)}$  and  $K_{(SET)}$  parameters are specified in the [Electrical Characteristics](#) table.

$$I_{O(PRECHG)} = \frac{K_{(SET)} \times V_{(PRECHG)}}{R_{SET}} \quad (1)$$

The device activates a safety timer,  $t_{(PRECHG)}$ , during the conditioning phase. If the  $V_{(LOWV)}$  threshold is not reached within the timer period, the device turns off the charger and enunciates FAULT on the STATx pins. See the [Timer Fault and Recovery](#) section for additional details.

### 8.3.2 Battery Fast-Charge Constant Current

The device offers on-chip current regulation with programmable set point. Resistor  $R_{SET}$ , connected between the ISET and  $V_{SS}$ , determines the charge rate. The  $V_{(SET)}$  and  $K_{(SET)}$  parameters are specified in the specifications table.

$$I_{O(OUT)} = \frac{K_{(SET)} \times V_{(SET)}}{R_{SET}} \quad (2)$$

### 8.3.3 Charge-Current Monitor

When the charge function is enabled internal circuits generate a current proportional to the charge current at the ISET pin. This current, when applied to the external charge current programming resistor  $R_{ISET}$  generates an analog voltage that can be monitored by an external host to calculate the current sourced from the OUT pin.

$$V_{(ISET)} = I_{(OUT)} \times \frac{R_{(ISET)}}{K_{(ISET)}} \quad (3)$$

### 8.3.4 Battery Fast-Charge Voltage Regulation

The voltage regulation feedback is through the OUT pin. This input is tied directly to the positive side of the battery pack. The device monitors the battery-pack voltage between the OUT and  $V_{SS}$  pins. When the battery voltage rises to the  $V_{O(REG)}$  threshold, the voltage regulation phase begins and the charging current begins to taper down.

As a safety backup, the device also monitors the charge time in the charge mode. If charge is not terminated within this time period,  $t_{(CHG)}$ , the charger is turned off and FAULT is set on the STATx pins. See the [Timer Fault and Recovery](#) section for additional details.

### 8.3.5 Charge Termination Detection and Recharge

The device monitors the charging current during the voltage regulation phase. Once the termination threshold,  $I_{(TERM)}$ , is detected, charge is terminated. The  $V_{(TERM)}$  and  $K_{(SET)}$  parameters are specified in the [Electrical Characteristics](#) table.

$$I_{O(TERM)} = \frac{K_{(SET)} \times V_{(TERM)}}{R_{SET}} \quad (4)$$

After charge termination, the device restarts the charge once the voltage on the OUT pin falls below the  $V_{(RCH)}$  threshold. This feature keeps the battery at full capacity at all times.

The device monitors the charging current during the voltage regulation phase. Once the termination threshold,  $I_{(TERM)}$ , is detected, the charge is terminated immediately.

Resistor  $R_{SET}$ , connected between the ISET and  $V_{SS}$ , determines the current level at the termination threshold.

## Feature Description (continued)

### 8.3.6 Charge Status Outputs

The open-drain STAT1 and STAT2 outputs indicate various charger operations as shown in [Table 1](#). These status pins can be used to drive LEDs or communicate to the host processor. Note that *OFF* indicates the open-drain transistor is turned off.

**Table 1. Status Pin Summary**

CHANGE STATE	STAT1	STAT2
Precharge in progress	ON	ON
Fast charge in progress	ON	OFF
Charge done	OFF	ON
Charge suspend (temperature)	OFF	OFF
Timer fault		
Sleep mode		

### 8.3.7 $\overline{\text{PG}}$ Output (bq24080-Q1)

The open-drain power-good ( $\overline{\text{PG}}$ ) output pulls low when a valid input voltage is present. This output is turned off (high-impedance) in sleep mode. The  $\overline{\text{PG}}$  pin can be used to drive an LED or communicate to the host processor.

### 8.3.8 Charge-Enabled ( $\overline{\text{CE}}$ ) Input (bq24080-Q1)

The  $\overline{\text{CE}}$  digital input is used to disable or enable the charge process. A low-level signal on this pin enables the charge and a high-level signal disables the charge and places the device in a low-power mode. A high-to-low transition on this pin also resets all timers and timer fault conditions.

### 8.3.9 Timer Enabled ( $\overline{\text{TE}}$ ) Input (bq24081-Q1)

The  $\overline{\text{TE}}$  digital input is used to disable or enable the fast-charge timer. A low-level signal on this pin enables the fast-charge timer, and a high-level signal disables this feature.

### 8.3.10 Temperature Qualification (bq24081-Q1)

The bq24081-Q1 continuously monitors battery temperature by measuring the voltage between the TS and  $V_{\text{SS}}$  pins. An internal current source provides the bias for common 10-k $\Omega$  negative-temperature-coefficient thermistors (NTC) (see the functional block diagram). The device compares the voltage on the TS pin with the internal  $V_{(\text{TS}1)}$  and  $V_{(\text{TS}2)}$  thresholds to determine if charging is allowed. If a temperature outside the  $V_{(\text{TS}1)}$  and  $V_{(\text{TS}2)}$  thresholds is detected, the device immediately suspends the charge by turning off the power FET and holding the timer value (i.e., timers are not reset). Charge is resumed when the temperature returns within the normal range.

The allowed temperature range with a 103AT-type thermistor is 0°C to 45°C. However, the user may modify these thresholds by adding external resistors (see [Figure 8](#) and [Figure 9](#)).

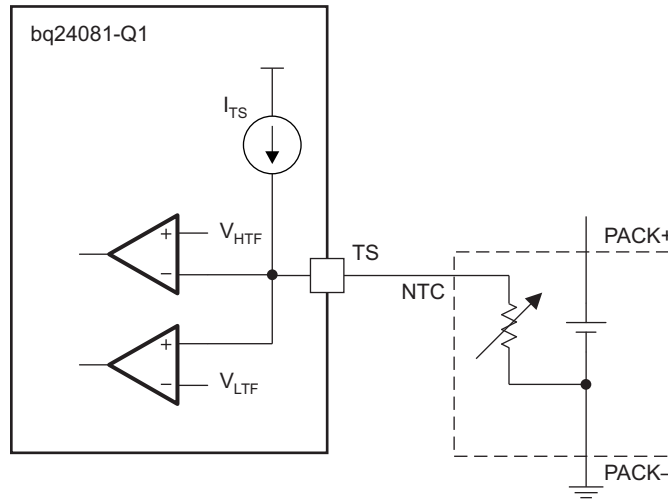

**Figure 8. Default Temperature Thresholds**

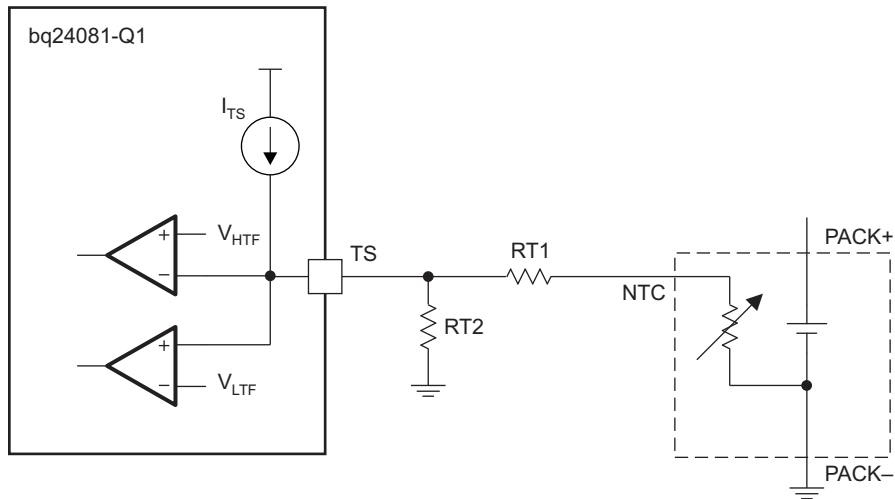

**Figure 9. Temperature Thresholds Modified by External Resistors**

### 8.3.11 Timer Fault and Recovery

As shown in [Figure 7](#), the device provides a recovery method to deal with timer fault conditions. The following summarizes this method:

#### 8.3.11.1 Condition Number 1

OUT pin voltage is above the recharge threshold ( $V_{(RCH)}$ ), and a timeout fault occurs.

Recovery method: the device waits for the OUT pin voltage to fall below the recharge threshold. This could happen as a result of a load on the battery, self-discharge, or battery removal. Once the OUT pin voltage falls below the recharge threshold, the device clears the fault and starts a new charge cycle. A POR,  $\overline{TE}$ , or  $\overline{CE}$  toggle also clears the fault.

#### 8.3.11.2 Condition Number 2

OUT pin voltage is below the recharge threshold ( $V_{(RCH)}$ ), and a timeout fault occurs

Recovery method: Under this scenario, the device applies the  $I_{(FAULT)}$  current. This small current is used to detect a battery removal condition and remains on as long as the battery voltage stays below the recharge threshold. If the OUT pin voltage goes above the recharge threshold, then the device disables the  $I_{(FAULT)}$  current and executes the recovery method described for condition number 1. Once the OUT pin voltage falls below the recharge threshold, the bq24080-Q1 clears the fault and starts a new charge cycle. A POR,  $\overline{TE}$ , or  $\overline{CE}$  toggle also clears the fault.

## 8.4 Device Functional Modes

### 8.4.1 Sleep Mode

The device enters the low-power sleep mode if the input power (IN) is removed from the circuit. This feature prevents draining the battery during the absence of input supply.

## 9 Application and Implementation

### NOTE

Information in the following applications sections is not part of the TI component specification, and TI does not warrant its accuracy or completeness. TI's customers are responsible for determining suitability of components for their purposes. Customers should validate and test their design implementation to confirm system functionality.

### 9.1 Application Information

The bq2408X-Q1 device is Lithium chemistry (Lithium Ion and Lithium Polymer) charger that is intended for automotive applications. The allows the designer to pick an automotive qualified charger for applications where the Li chemistry is needed. Such applications may involve E-Call (back up safety call) or infotainment systems within the automotive space. The device comes completely ready with an integrated charge current monitor and safety timers. The LDO based charger design allows for a cost optimized safe charging algorithm.

### 9.2 Typical Application

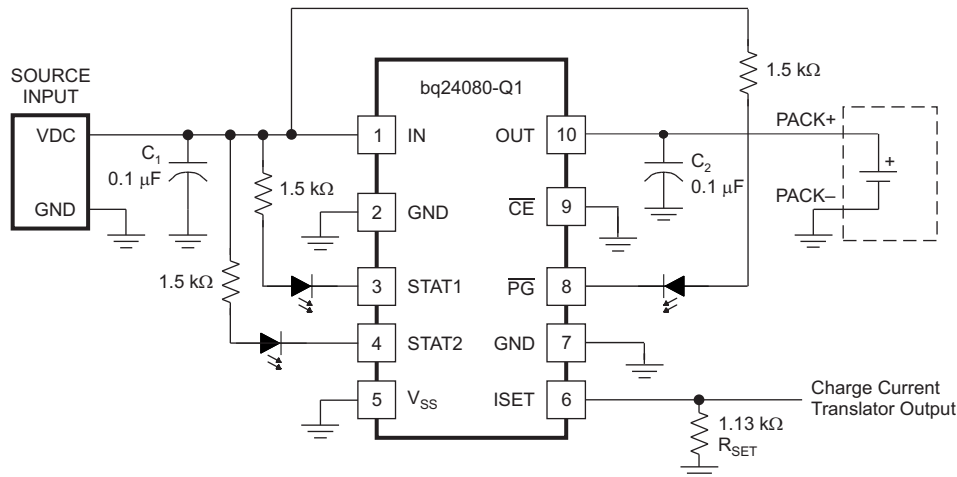

Figure 10. Typical Application Circuit

#### 9.2.1 Design Requirements

For this design example, use the parameters shown in [Table 2](#).

Table 2. Design Parameters

PARAMETER	VALUE
Supply voltage	5 V
Fast-charge current	≈ 750 mA
Battery-Temperature sense (bq24081-Q1)	-2°C to 44.5°C (default setting)

## 9.2.2 Detailed Design Procedure

### 9.2.2.1 Calculations

Program the charge current for 750 mA:

$$R_{\text{ISET}} = [V_{(\text{SET})} \times K_{(\text{SET})} / I_{(\text{OUT})}] \quad (5)$$

From [Electrical Characteristics](#) table,  $V_{(\text{SET})} = 2.5 \text{ V}$ .

From [Electrical Characteristics](#) table,  $K_{(\text{SET})} = 322$ .

$$R_{\text{ISET}} = [2.5 \text{ V} \times 322 / 0.75 \text{ A}] = 1.073 \text{ k}\Omega \quad (6)$$

Selecting the closest standard value, use a 1.07-k $\Omega$  resistor connected between ISET (pin 6) and ground.

### 9.2.2.2 Battery Temperature Sense (bq24081-Q1):

Use a Semitec 103AT-4 NTC thermistor connected between TS (pin 9) and ground.

$$R_{\text{THERM-cold}} = [V_{(\text{TS1})} / I_{(\text{TS})}] = 2.5 \text{ V} / 100 \mu\text{A} = 25 \text{ k}\Omega \quad (7)$$

$$R_{\text{THERM-hot}} = [V_{(\text{TS2})} / I_{(\text{TS})}] = 0.5 \text{ V} / 100 \mu\text{A} = 5 \text{ k}\Omega \quad (8)$$

Look up the corresponding temperature value in the manufacturer's resistance-temperature table for the thermistor selected. For a 103AT-4 Semitec thermistor:

$$5 \text{ k}\Omega = 44.5^\circ\text{C}$$

$$25 \text{ k}\Omega = 2^\circ\text{C}$$

### 9.2.2.3 STAT Pins (All Devices) and PG Pin (bq24080-Q1):

Status pins Monitored by Processor:

Select a pullup resistor that can source more than the input bias (leakage) current of both the processor and status pins and still provide a logic high.

$$R_{\text{PULLUP}} \leq [V_{(\text{CC-pullup})} - V_{(\text{logic hi-min})} / (I_{(\mu\text{P-monitor})} + I_{(\text{STAT-OpenDrain})})] = (3.3 \text{ V} - 1.9 \text{ V}) / (1 \mu\text{A} + 1 \mu\text{A}) \leq 700 \text{ k}\Omega; \quad (9)$$

Connect a 100-k $\Omega$  pullup between each status pin and the  $V_{\text{CC}}$  of the processor. Connect each status pin to a  $\mu\text{P}$  monitor pin.

Status viewed by LED:

Select an LED with a current rating less than 10 mA and select a resistor to place in series with the LED to limit the current to the desired current value (brightness).

$$R_{\text{LED}} = [(V_{(\text{IN})} - V_{(\text{LED-on})}) / I_{(\text{LED})}] = (5 \text{ V} - 2 \text{ V}) / 1.5 \text{ mA} = 2 \text{ k}\Omega. \quad (10)$$

Place an LED and resistor in series between the input and each status pin.

### 9.2.2.4 Selecting Input and Output Capacitors

In most applications, all that is needed is a high-frequency decoupling capacitor on the input power pin. A 0.1- $\mu\text{F}$  ceramic capacitor, placed in close proximity to the IN pin and GND pad works well. In some applications, it may be necessary to protect against a hot plug input voltage overshoot. This is done in three ways:

1. The best way is to add an input zener, 6.2 V, between the IN pin and  $V_{\text{SS}}$ .
2. A low-power zener is adequate for the single event transient. Increasing the input capacitance lowers the characteristic impedance which makes the input resistance more effective at damping the overshoot, but risks damaging the input contacts by the high inrush current.
3. Placing a resistor in series with the input dampens the overshoot, but causes excess power dissipation.

The device only requires a small capacitor for loop stability. A 0.1- $\mu\text{F}$  ceramic capacitor placed between the OUT and GND pad is typically sufficient.



### 9.2.3 Application Curves

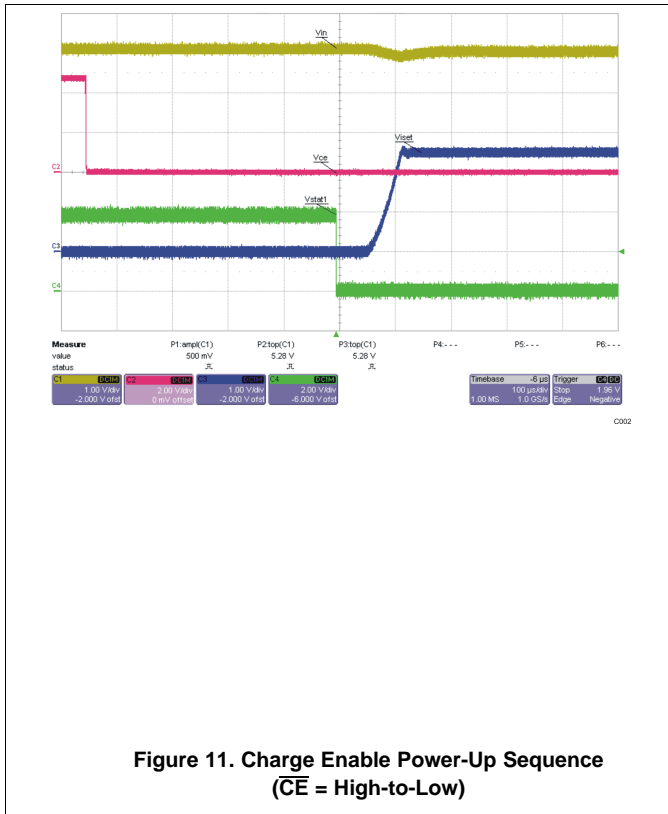

Figure 11. Charge Enable Power-Up Sequence (CE = High-to-Low)

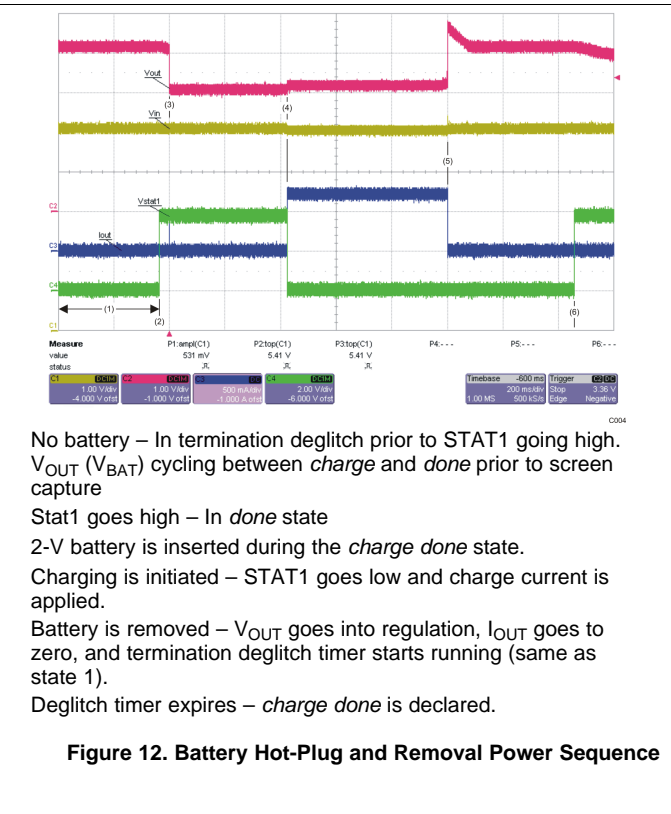

Figure 12. Battery Hot-Plug and Removal Power Sequence

No battery – In termination deglitch prior to STAT1 going high.  $V_{OUT}$  ( $V_{BAT}$ ) cycling between *charge* and *done* prior to screen capture  
 Stat1 goes high – In *done* state  
 2-V battery is inserted during the *charge done* state.  
 Charging is initiated – STAT1 goes low and charge current is applied.  
 Battery is removed –  $V_{OUT}$  goes into regulation,  $I_{OUT}$  goes to zero, and termination deglitch timer starts running (same as state 1).  
 Deglitch timer expires – *charge done* is declared.

## 10 Power Supply Recommendations

The devices are intended to operate within the ranges shown in Recommended Operating Conditions. Because the input of the device on pin IN is subject to a power source that is external, care must be taken to not exercise the pin above the Absolute Maximum Rating of the Pin shown in the [Absolute Maximum Ratings](#) table.

## 11 Layout

### 11.1 Layout Guidelines

It is important to pay special attention to the PCB layout. The following provides some guidelines:

- To obtain optimal performance, the decoupling capacitor from  $V_{CC}$  to  $V_{(IN)}$  and the output filter capacitors from OUT to  $V_{SS}$  should be placed as close as possible to the device, with short trace runs to both signal and  $V_{SS}$  pins. The  $V_{SS}$  pin should have short trace runs to the GND pin.
- All low-current  $V_{SS}$  connections should be kept separate from the high-current charge or discharge paths from the battery. Use a single-point ground technique incorporating both the small-signal ground path and the power ground path.
- The high-current charge paths into IN and from the OUT pins must be sized appropriately for the maximum charge current in order to avoid voltage drops in these traces.
- The device is packaged in a thermally enhanced MLP package. The package includes a thermal pad to provide an effective thermal contact between the device and the printed circuit board (PCB). Full PCB design guidelines for this package are provided in the application report entitled, *QFN/SON PCB Attachment* (TI Literature Number [SLUA271](#)).

### 11.2 Layout Example

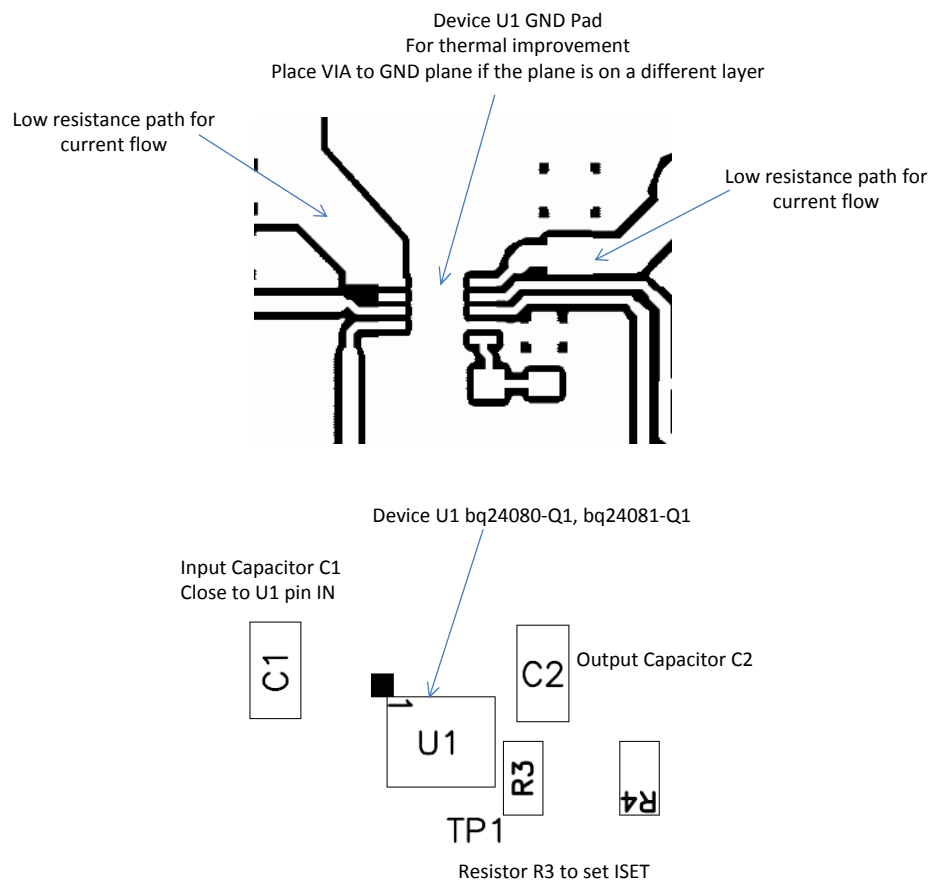

**Figure 13. Board Layout**

### 11.3 Thermal Considerations

The bq24080-Q1 and bq24081-Q1 are packaged in a thermally enhanced MLP package. The package includes a thermal pad to provide an effective thermal contact between the device and the printed-circuit board (PCB). Full PCB design guidelines for this package are provided in the application report entitled, *QFN/SON PCB Attachment* (TI Literature Number [SLUA271](#)).

The most common measure of package thermal performance is thermal impedance ( $R_{\theta JA}$ ) measured (or modeled) from the device junction to the air surrounding the package surface (ambient). The mathematical expression for  $R_{\theta JA}$  is:

$$R_{\theta JA} = \frac{T_J - T_A}{P} \quad (11)$$

Where:

- $T_J$  = device junction temperature
- $T_A$  = ambient temperature
- $P$  = device power dissipation

Factors that can greatly influence the measurement and calculation of  $R_{\theta JA}$  include:

- Orientation of the device (horizontal or vertical)
- Volume of the ambient air surrounding the device under test and airflow
- Whether other surfaces are in close proximity to the device being tested
- Use multiple 10–13 mil vias in the PowerPAD™ to copper ground plane.
- Avoid cutting the ground plane with a signal trace near the power IC.
- The PCB must be sized to have adequate surface area for heat dissipation.
- FR4 (figerglass) thickness should be minimized.

The device power dissipation,  $P$ , is a function of the charge rate and the voltage drop across the internal Power FET. It can be calculated from the following equation:

$$P = (V_{(IN)} - V_{(OUT)}) \times I_{O(OUT)} \quad (12)$$

Due to the charge profile of Li-xx batteries, the maximum power dissipation is typically seen at the beginning of the charge cycle when the battery voltage is at its lowest. See [Figure 6](#).

## 12 Device and Documentation Support

### 12.1 Device Support

### 12.2 Documentation Support

*QFN/SON PCB Attachment*, ([SLUA271](#)).

### 12.3 Related Links

The table below lists quick access links. Categories include technical documents, support and community resources, tools and software, and quick access to sample or buy.

**Table 3. Related Links**

PARTS	PRODUCT FOLDER	SAMPLE & BUY	TECHNICAL DOCUMENTS	TOOLS & SOFTWARE	SUPPORT & COMMUNITY
bq24080-Q1	<a href="#">Click here</a>	<a href="#">Click here</a>	<a href="#">Click here</a>	<a href="#">Click here</a>	<a href="#">Click here</a>
bq24081-Q1	<a href="#">Click here</a>	<a href="#">Click here</a>	<a href="#">Click here</a>	<a href="#">Click here</a>	<a href="#">Click here</a>

### 12.4 Community Resources

The following links connect to TI community resources. Linked contents are provided "AS IS" by the respective contributors. They do not constitute TI specifications and do not necessarily reflect TI's views; see TI's [Terms of Use](#).

**TI E2E™ Online Community** *TI's Engineer-to-Engineer (E2E) Community*. Created to foster collaboration among engineers. At [e2e.ti.com](http://e2e.ti.com), you can ask questions, share knowledge, explore ideas and help solve problems with fellow engineers.

**Design Support** *TI's Design Support* Quickly find helpful E2E forums along with design support tools and contact information for technical support.

### 12.5 Trademarks

PowerPAD, E2E are trademarks of Texas Instruments.  
All other trademarks are the property of their respective owners.

### 12.6 Electrostatic Discharge Caution



These devices have limited built-in ESD protection. The leads should be shorted together or the device placed in conductive foam during storage or handling to prevent electrostatic damage to the MOS gates.

### 12.7 Glossary

[SLYZ022](#) — *TI Glossary*.

This glossary lists and explains terms, acronyms, and definitions.

## 13 Mechanical, Packaging, and Orderable Information

The following pages include mechanical, packaging, and orderable information. This information is the most current data available for the designated devices. This data is subject to change without notice and revision of this document. For browser-based versions of this data sheet, refer to the left-hand navigation.

**PACKAGING INFORMATION**

Orderable Device	Status (1)	Package Type	Package Drawing	Pins	Package Qty	Eco Plan (2)	Lead/Ball Finish (6)	MSL Peak Temp (3)	Op Temp (°C)	Device Marking (4/5)	Samples
BQ24081QDRCRQ1	ACTIVE	VSON	DRC	10	3000	Green (RoHS & no Sb/Br)	CU NIPDAU	Level-3-260C-168 HR	-40 to 125	ZACQ	Samples
BQ24081QDRCTQ1	PREVIEW	VSON	DRC	10	250	TBD	Call TI	Call TI	-40 to 125		

(1) The marketing status values are defined as follows:

**ACTIVE:** Product device recommended for new designs.

**LIFEBUY:** TI has announced that the device will be discontinued, and a lifetime-buy period is in effect.

**NRND:** Not recommended for new designs. Device is in production to support existing customers, but TI does not recommend using this part in a new design.

**PREVIEW:** Device has been announced but is not in production. Samples may or may not be available.

**OBSOLETE:** TI has discontinued the production of the device.

(2) Eco Plan - The planned eco-friendly classification: Pb-Free (RoHS), Pb-Free (RoHS Exempt), or Green (RoHS & no Sb/Br) - please check <http://www.ti.com/productcontent> for the latest availability information and additional product content details.

**TBD:** The Pb-Free/Green conversion plan has not been defined.

**Pb-Free (RoHS):** TI's terms "Lead-Free" or "Pb-Free" mean semiconductor products that are compatible with the current RoHS requirements for all 6 substances, including the requirement that lead not exceed 0.1% by weight in homogeneous materials. Where designed to be soldered at high temperatures, TI Pb-Free products are suitable for use in specified lead-free processes.

**Pb-Free (RoHS Exempt):** This component has a RoHS exemption for either 1) lead-based flip-chip solder bumps used between the die and package, or 2) lead-based die adhesive used between the die and leadframe. The component is otherwise considered Pb-Free (RoHS compatible) as defined above.

**Green (RoHS & no Sb/Br):** TI defines "Green" to mean Pb-Free (RoHS compatible), and free of Bromine (Br) and Antimony (Sb) based flame retardants (Br or Sb do not exceed 0.1% by weight in homogeneous material)

(3) MSL, Peak Temp. - The Moisture Sensitivity Level rating according to the JEDEC industry standard classifications, and peak solder temperature.

(4) There may be additional marking, which relates to the logo, the lot trace code information, or the environmental category on the device.

(5) Multiple Device Markings will be inside parentheses. Only one Device Marking contained in parentheses and separated by a "~" will appear on a device. If a line is indented then it is a continuation of the previous line and the two combined represent the entire Device Marking for that device.

(6) Lead/Ball Finish - Orderable Devices may have multiple material finish options. Finish options are separated by a vertical ruled line. Lead/Ball Finish values may wrap to two lines if the finish value exceeds the maximum column width.

**Important Information and Disclaimer:** The information provided on this page represents TI's knowledge and belief as of the date that it is provided. TI bases its knowledge and belief on information provided by third parties, and makes no representation or warranty as to the accuracy of such information. Efforts are underway to better integrate information from third parties. TI has taken and continues to take reasonable steps to provide representative and accurate information but may not have conducted destructive testing or chemical analysis on incoming materials and chemicals. TI and TI suppliers consider certain information to be proprietary, and thus CAS numbers and other limited information may not be available for release.

In no event shall TI's liability arising out of such information exceed the total purchase price of the TI part(s) at issue in this document sold by TI to Customer on an annual basis.

**OTHER QUALIFIED VERSIONS OF BQ24081-Q1 :**

- Catalog: [BQ24081](#)

NOTE: Qualified Version Definitions:

- Catalog - TI's standard catalog product

## TAPE AND REEL INFORMATION

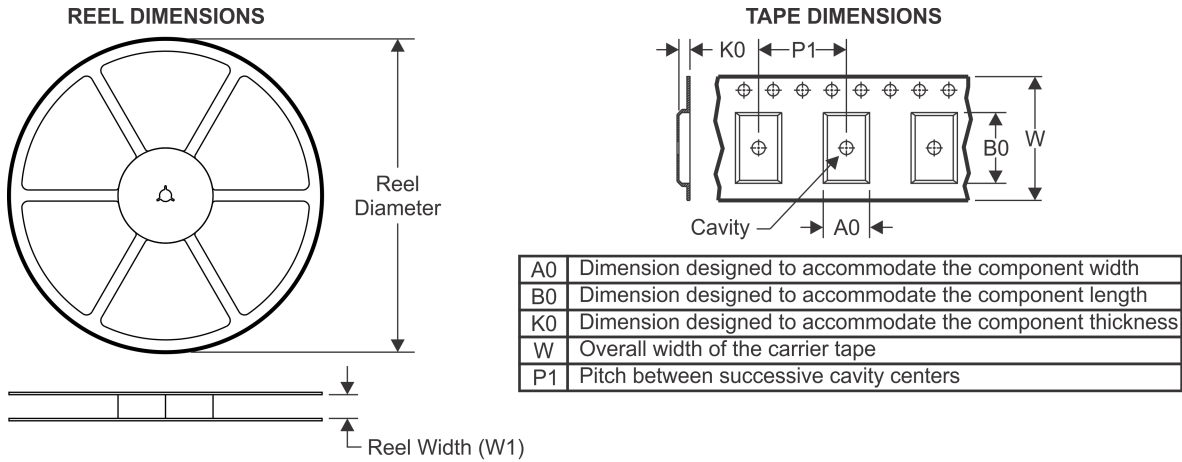

### QUADRANT ASSIGNMENTS FOR PIN 1 ORIENTATION IN TAPE

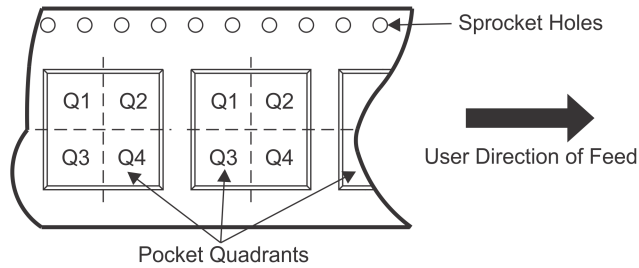

\*All dimensions are nominal

Device	Package Type	Package Drawing	Pins	SPQ	Reel Diameter (mm)	Reel Width W1 (mm)	A0 (mm)	B0 (mm)	K0 (mm)	P1 (mm)	W (mm)	Pin1 Quadrant
BQ24081QDRCRQ1	VSON	DRC	10	3000	330.0	12.4	3.3	3.3	1.1	8.0	12.0	Q2

TAPE AND REEL BOX DIMENSIONS



\*All dimensions are nominal

Device	Package Type	Package Drawing	Pins	SPQ	Length (mm)	Width (mm)	Height (mm)
BQ24081QDRCRQ1	VSON	DRC	10	3000	367.0	367.0	35.0



DRC (S-PVSON-N10)

PLASTIC SMALL OUTLINE NO-LEAD

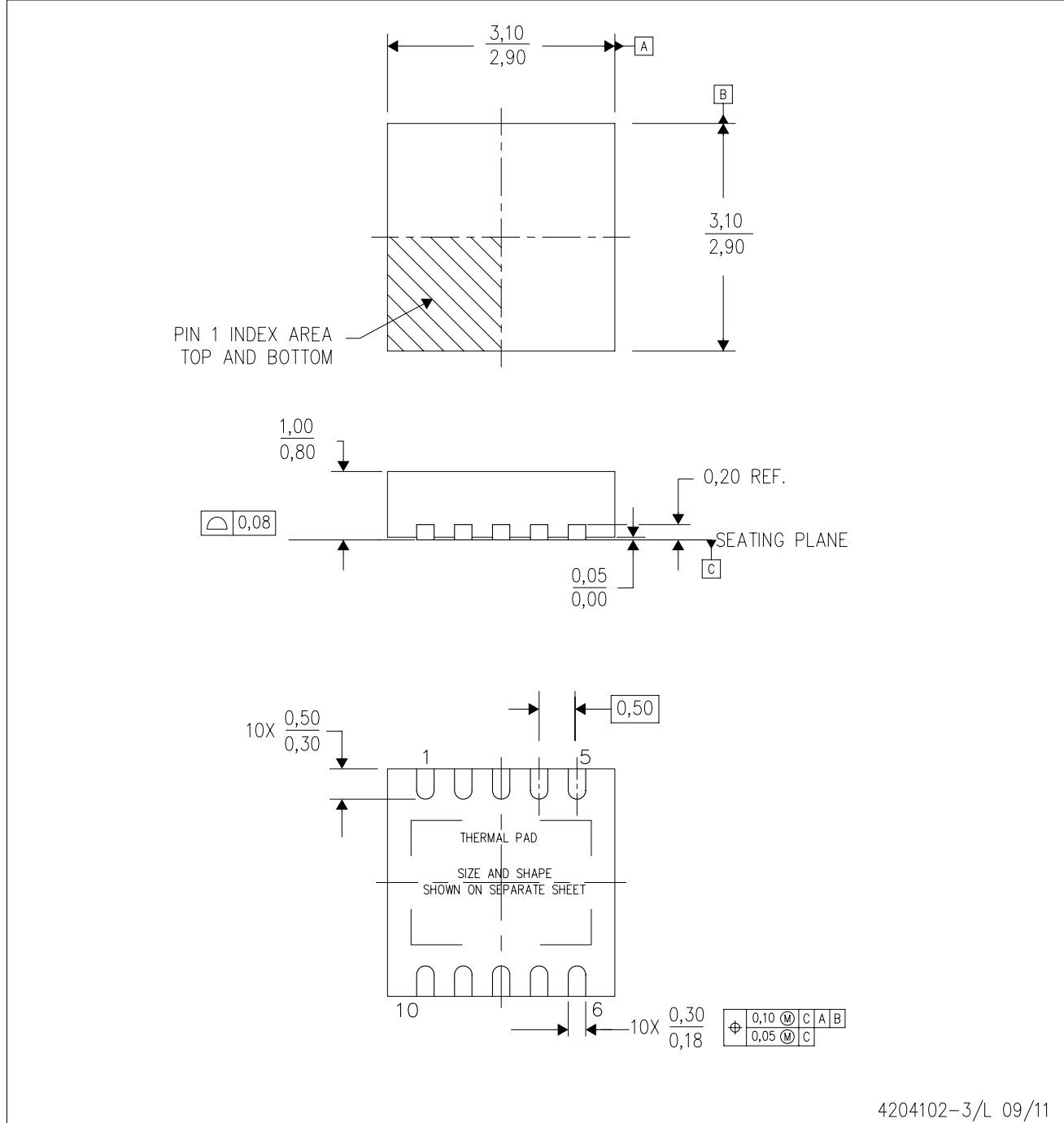

- NOTES:
- All linear dimensions are in millimeters. Dimensioning and tolerancing per ASME Y14.5M-1994.
  - This drawing is subject to change without notice.
  - Small Outline No-Lead (SON) package configuration.
  - The package thermal pad must be soldered to the board for thermal and mechanical performance, if present.
  - See the additional figure in the Product Data Sheet for details regarding the exposed thermal pad features and dimensions, if present

# THERMAL PAD MECHANICAL DATA

DRC (S-PVSON-N10)

PLASTIC SMALL OUTLINE NO-LEAD

## THERMAL INFORMATION

This package incorporates an exposed thermal pad that is designed to be attached directly to an external heatsink. The thermal pad must be soldered directly to the printed circuit board (PCB). After soldering, the PCB can be used as a heatsink. In addition, through the use of thermal vias, the thermal pad can be attached directly to the appropriate copper plane shown in the electrical schematic for the device, or alternatively, can be attached to a special heatsink structure designed into the PCB. This design optimizes the heat transfer from the integrated circuit (IC).

For information on the Quad Flatpack No-Lead (QFN) package and its advantages, refer to Application Report, QFN/SON PCB Attachment, Texas Instruments Literature No. SLUA271. This document is available at [www.ti.com](http://www.ti.com).

The exposed thermal pad dimensions for this package are shown in the following illustration.

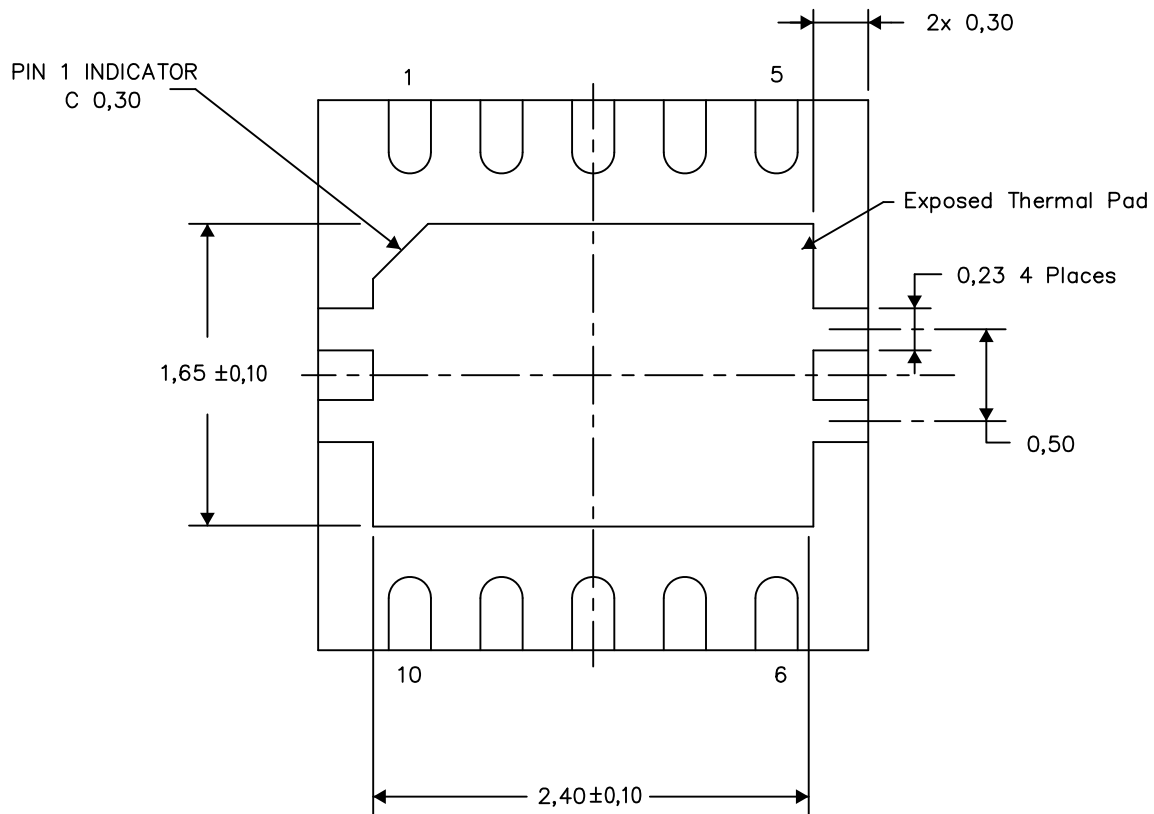

Bottom View

Exposed Thermal Pad Dimensions

4206565-3/W 04/15

NOTE: A. All linear dimensions are in millimeters

DRC (S-PVSON-N10)

PLASTIC SMALL OUTLINE NO-LEAD

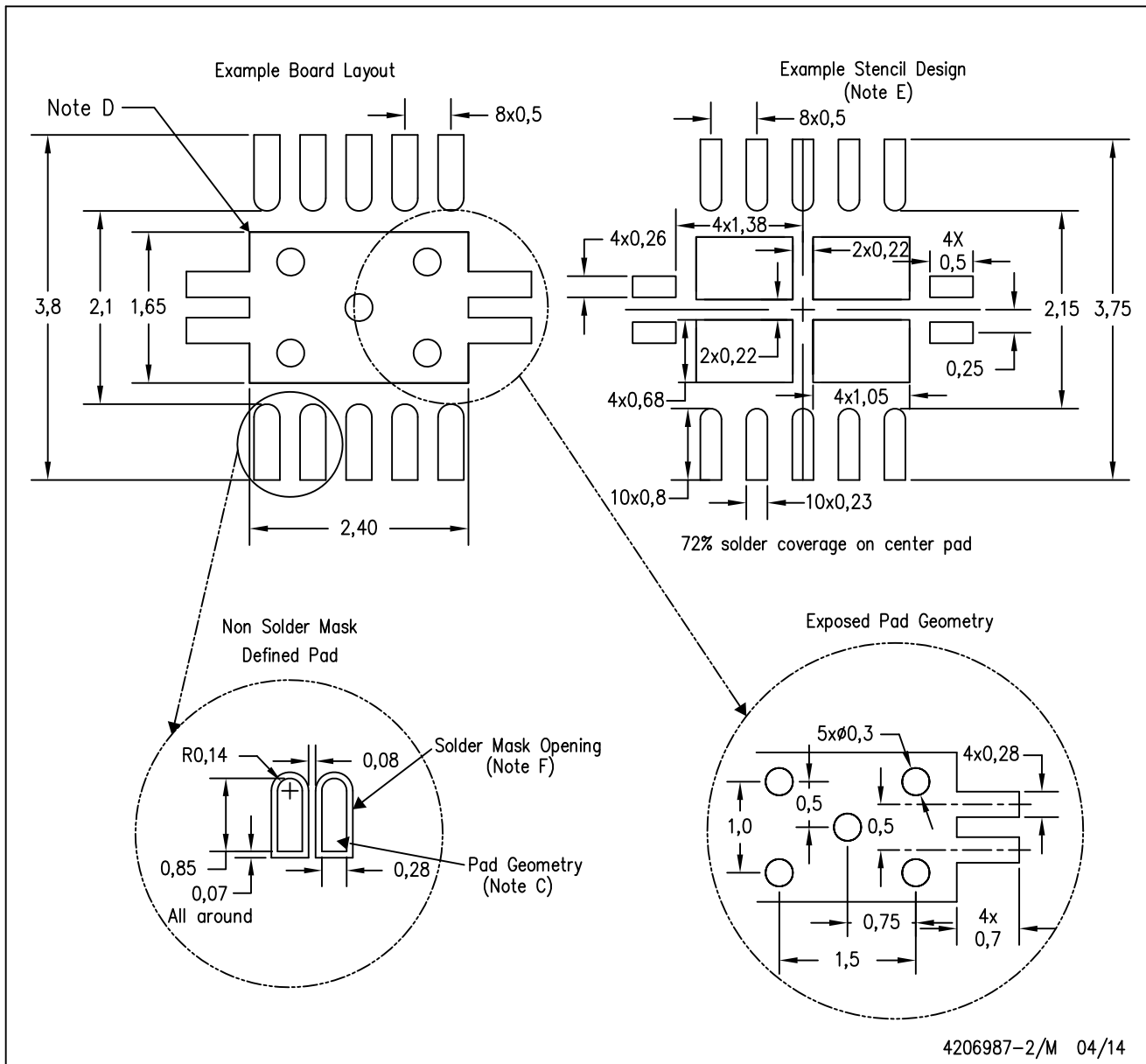

- NOTES:
- All linear dimensions are in millimeters.
  - This drawing is subject to change without notice.
  - Publication IPC-7351 is recommended for alternate designs.
  - This package is designed to be soldered to a thermal pad on the board. Refer to Application Note, Quad Flat-Pack Packages, Texas Instruments Literature No. SLUA271, and also the Product Data Sheets for specific thermal information, via requirements, and recommended board layout. These documents are available at [www.ti.com](http://www.ti.com) <<http://www.ti.com>>.
  - Laser cutting apertures with trapezoidal walls and also rounding corners will offer better paste release. Customers should contact their board assembly site for stencil design recommendations. Refer to IPC 7525 for stencil design considerations.
  - Customers should contact their board fabrication site for minimum solder mask web tolerances between signal pads.

## IMPORTANT NOTICE

Texas Instruments Incorporated and its subsidiaries (TI) reserve the right to make corrections, enhancements, improvements and other changes to its semiconductor products and services per JESD46, latest issue, and to discontinue any product or service per JESD48, latest issue. Buyers should obtain the latest relevant information before placing orders and should verify that such information is current and complete. All semiconductor products (also referred to herein as "components") are sold subject to TI's terms and conditions of sale supplied at the time of order acknowledgment.

TI warrants performance of its components to the specifications applicable at the time of sale, in accordance with the warranty in TI's terms and conditions of sale of semiconductor products. Testing and other quality control techniques are used to the extent TI deems necessary to support this warranty. Except where mandated by applicable law, testing of all parameters of each component is not necessarily performed.

TI assumes no liability for applications assistance or the design of Buyers' products. Buyers are responsible for their products and applications using TI components. To minimize the risks associated with Buyers' products and applications, Buyers should provide adequate design and operating safeguards.

TI does not warrant or represent that any license, either express or implied, is granted under any patent right, copyright, mask work right, or other intellectual property right relating to any combination, machine, or process in which TI components or services are used. Information published by TI regarding third-party products or services does not constitute a license to use such products or services or a warranty or endorsement thereof. Use of such information may require a license from a third party under the patents or other intellectual property of the third party, or a license from TI under the patents or other intellectual property of TI.

Reproduction of significant portions of TI information in TI data books or data sheets is permissible only if reproduction is without alteration and is accompanied by all associated warranties, conditions, limitations, and notices. TI is not responsible or liable for such altered documentation. Information of third parties may be subject to additional restrictions.

Resale of TI components or services with statements different from or beyond the parameters stated by TI for that component or service voids all express and any implied warranties for the associated TI component or service and is an unfair and deceptive business practice. TI is not responsible or liable for any such statements.

Buyer acknowledges and agrees that it is solely responsible for compliance with all legal, regulatory and safety-related requirements concerning its products, and any use of TI components in its applications, notwithstanding any applications-related information or support that may be provided by TI. Buyer represents and agrees that it has all the necessary expertise to create and implement safeguards which anticipate dangerous consequences of failures, monitor failures and their consequences, lessen the likelihood of failures that might cause harm and take appropriate remedial actions. Buyer will fully indemnify TI and its representatives against any damages arising out of the use of any TI components in safety-critical applications.

In some cases, TI components may be promoted specifically to facilitate safety-related applications. With such components, TI's goal is to help enable customers to design and create their own end-product solutions that meet applicable functional safety standards and requirements. Nonetheless, such components are subject to these terms.

No TI components are authorized for use in FDA Class III (or similar life-critical medical equipment) unless authorized officers of the parties have executed a special agreement specifically governing such use.

Only those TI components which TI has specifically designated as military grade or "enhanced plastic" are designed and intended for use in military/aerospace applications or environments. Buyer acknowledges and agrees that any military or aerospace use of TI components which have **not** been so designated is solely at the Buyer's risk, and that Buyer is solely responsible for compliance with all legal and regulatory requirements in connection with such use.

TI has specifically designated certain components as meeting ISO/TS16949 requirements, mainly for automotive use. In any case of use of non-designated products, TI will not be responsible for any failure to meet ISO/TS16949.

### Products

Audio	<a href="http://www.ti.com/audio">www.ti.com/audio</a>
Amplifiers	<a href="http://amplifier.ti.com">amplifier.ti.com</a>
Data Converters	<a href="http://dataconverter.ti.com">dataconverter.ti.com</a>
DLP® Products	<a href="http://www.dlp.com">www.dlp.com</a>
DSP	<a href="http://dsp.ti.com">dsp.ti.com</a>
Clocks and Timers	<a href="http://www.ti.com/clocks">www.ti.com/clocks</a>
Interface	<a href="http://interface.ti.com">interface.ti.com</a>
Logic	<a href="http://logic.ti.com">logic.ti.com</a>
Power Mgmt	<a href="http://power.ti.com">power.ti.com</a>
Microcontrollers	<a href="http://microcontroller.ti.com">microcontroller.ti.com</a>
RFID	<a href="http://www.ti-rfid.com">www.ti-rfid.com</a>
OMAP Applications Processors	<a href="http://www.ti.com/omap">www.ti.com/omap</a>
Wireless Connectivity	<a href="http://www.ti.com/wirelessconnectivity">www.ti.com/wirelessconnectivity</a>

### Applications

Automotive and Transportation	<a href="http://www.ti.com/automotive">www.ti.com/automotive</a>
Communications and Telecom	<a href="http://www.ti.com/communications">www.ti.com/communications</a>
Computers and Peripherals	<a href="http://www.ti.com/computers">www.ti.com/computers</a>
Consumer Electronics	<a href="http://www.ti.com/consumer-apps">www.ti.com/consumer-apps</a>
Energy and Lighting	<a href="http://www.ti.com/energy">www.ti.com/energy</a>
Industrial	<a href="http://www.ti.com/industrial">www.ti.com/industrial</a>
Medical	<a href="http://www.ti.com/medical">www.ti.com/medical</a>
Security	<a href="http://www.ti.com/security">www.ti.com/security</a>
Space, Avionics and Defense	<a href="http://www.ti.com/space-avionics-defense">www.ti.com/space-avionics-defense</a>
Video and Imaging	<a href="http://www.ti.com/video">www.ti.com/video</a>

### TI E2E Community

[e2e.ti.com](http://e2e.ti.com)