

Housing - HC-STA-D07-HHFS-1SGM20-PL-BK



1419257

<https://www.phoenixcontact.com/us/products/1419257>

Please be informed that the data shown in this PDF document is generated from our Online Catalog. Please find the complete data in the user documentation. Our General Terms of Use for Downloads are valid.



Sleeve housing D7, for single locking latch, material: PA, cable outlets: 1, lateral, M20, height: 54.5 mm, cable gland: with, Standard

Commercial Data

Item number	1419257
Packing unit	1 pc
Minimum order quantity	1 pc
Sales Key	B10
Product Key	BF7APD
Catalog Page	Page 514 (C-2-2019)
GTIN	4055626159980
Weight per Piece (including packing)	26.825 g
Weight per Piece (excluding packing)	26 g
Customs tariff number	85389099
Country of origin	CN

1419257

<https://www.phoenixcontact.com/us/products/1419257>

Technical Data

Notes

General	for contact inserts HC-A03, A04, D07, D08, Q02, Q03, Q04, Q05, Q07, Q12
---------	---

Product properties

Type	D7
Product type	Housing with locking latch
Application	Standard
No. of cable outlets	1
Type of the screw connection	M20
Housing type	Sleeve housing
Locking type	for single locking latch
Shielded	no
Cable outlet	lateral
Pg screw connection	with

Dimensions

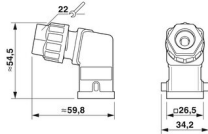
Dimensional drawing	
Width	26.5 mm
Height	54.5 mm
Length	26.5 mm

Material specifications

Color	black
Flammability rating according to UL 94	V0 (Housing)
Locking latch material	PA
Impact strength	IK06
Housing material	PA

Characteristics

External cable diameter	4 mm ... 10 mm
-------------------------	----------------

Mechanical properties

Mechanical data

Type of the screw connection	M20
Locking type	Pin

Ambient conditions

Housing - HC-STA-D07-HHFS-1SGM20-PL-BK



1419257

<https://www.phoenixcontact.com/us/products/1419257>

Degree of protection	IP66
Impact strength	IK06
Ambient temperature (operation)	-40 °C ... 125 °C

Housing - HC-STA-D07-HHFS-1SGM20-PL-BK



1419257

<https://www.phoenixcontact.com/us/products/1419257>

Drawings

Dimensional drawing

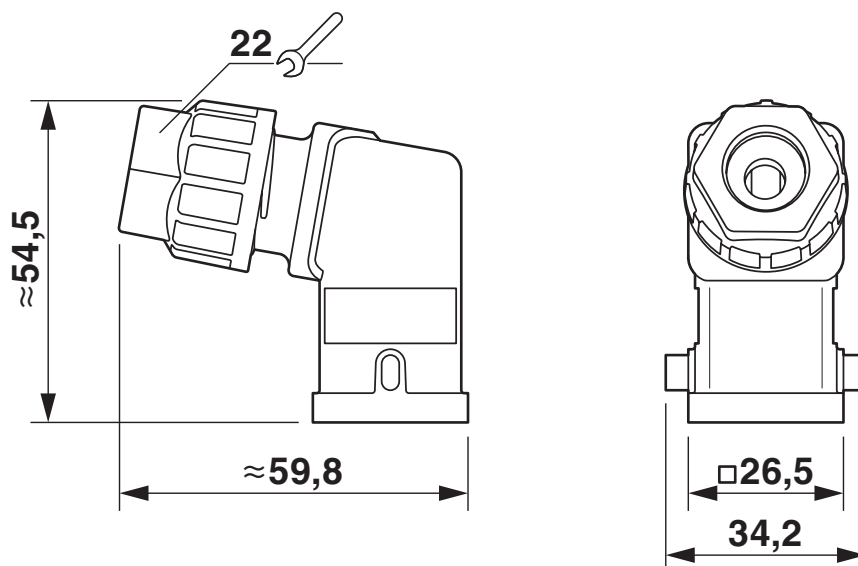

Dimensional drawing

Housing - HC-STA-D07-HHFS-1SGM20-PL-BK



1419257

<https://www.phoenixcontact.com/us/products/1419257>

Approvals

DNV

Approval ID: TAE000037S



EAC

Approval ID: RU C-DE.AI30.B.01102



EAC

Approval ID: RU C-DE.BL08.B.00511

1419257

<https://www.phoenixcontact.com/us/products/1419257>

Classifications

ECLASS

ECLASS-9.0	27440202
ECLASS-10.0.1	27440202
ECLASS-11.0	27440202

ETIM

ETIM 8.0	EC000437
----------	----------

UNSPSC

UNSPSC 21.0	31261500
-------------	----------

Housing - HC-STA-D07-HHFS-1SGM20-PL-BK



1419257

<https://www.phoenixcontact.com/us/products/1419257>

Environmental Product Compliance

China RoHS	Environmentally friendly use period: unlimited = EFUP-e
	No hazardous substances above threshold values

Housing - HC-STA-D07-HHFS-1SGM20-PL-BK



1419257

<https://www.phoenixcontact.com/us/products/1419257>

Accessories

Plastic label

Plastic label - US-EMLP (20X9) CUS - 0830085

<https://www.phoenixcontact.com/us/products/0830085>

Plastic label, can be ordered: by card, white, labeled according to customer specifications, mounting type: adhesive, lettering field size: 20 x 9 mm, Number of individual labels: 75



Phoenix Contact 2022 © - all rights reserved
<https://www.phoenixcontact.com>

Phoenix Contact USA
586 Fulling Mill Road
Middletown, PA 17057, United States
(+717) 944-1300
info@phoenixcon.com