

DWG NO. 36-00029-06 SH 1 REV C1

REVISIONS				
ECO	REV	DESCRIPTION	DATE	APPROVED
687	A	CHANGED MATERIAL	7-25-97	RBD
730	B	CHG: NOTE 2.1, WAS: L = 56 UH	12-18-97	RBD
1023	C	CHG: NOTES 2.1, & 3.3 PER ECO	05-15-00	RBD
---	C1	ADD PERMACORE 87-9040-26	11/10/00	RBD

PROPRIETARY DATA:  
 This document and information contained  
 hereon is not to be reproduced, used or disclosed  
 without prior written permission of WESTCOR  
 a division of VICOR Corporation.

NOTES: UNLESS OTHERWISE SPECIFIED

1. MATERIALS: UL RECOGNIZED 94V-2  
 FLAMMABILITY RATING CLASS B (130°C)  
 REQUIRED.

1.1 CORE: TOROID,  $\mu = 5000$

MAGNETICS: ZJ-43806-TC OR  
 PERMACOR: 87-9040-26

1.2 WIRE: U.L. RECOGNIZED 130°C RATING  
 MAGNET WIRE

1.3 OUTER WRAP: 3M #11 OR #69  
 OR PERMASIL #213 OR 286

2. SPECIFICATIONS:

- 2.1 L = 52  $\mu$ H MIN/COIL (1 KHZ, <1V<sub>rms</sub>)
- 2.2 DCR = .4 M $\Omega$  MAX/COIL
- 2.3 POWER LOSS = 5.2W MAX @ 80A/COIL
- 2.4 HI-POT TEST COIL TO COIL, 250VDC  
 TO INSURE INTEGRITY OF WINDING  
 INSULATION COVERING HAS NOT BEEN  
 BREACHED.



3. CONSTRUCTION:

3.1 WIND COILS EVENLY SPACED (NOTE  
 POLARITY)

3.2 REMOVE INSULATION AND TIN LEADS APPROX  
 FLUSH WITH THE COIL, AS SHOWN (I.E. COIL  
 MUST REST FLAT ON PCB). LEADS MUST BE  
 TANGENT TO THE CORE.

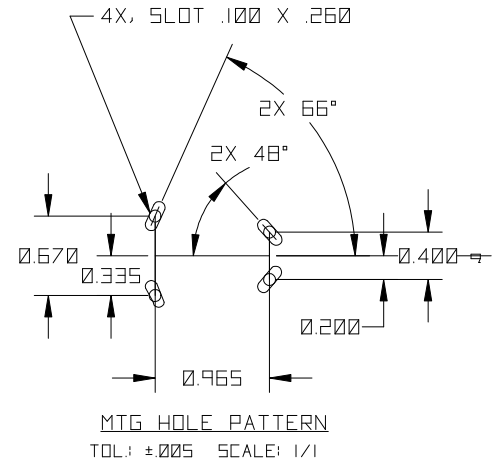
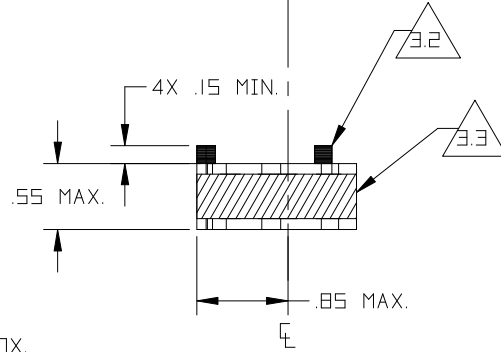
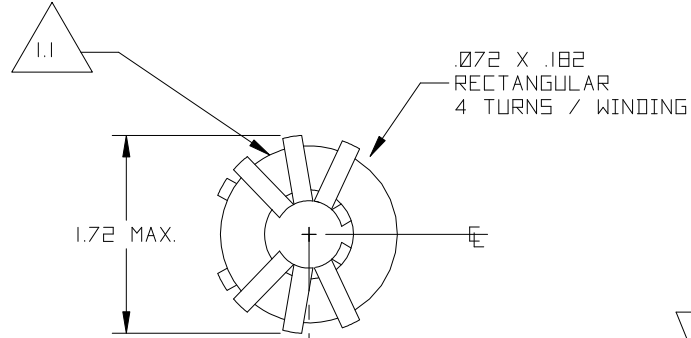
3.3 WRAP INDUCTOR WITH TAPE, (PER NOTE 1.3).  
 MARK PART NUMBER AND REVISION IN (BLACK) APPROX.  
 WHERE SHOWN, USING A PERMANENT MARKING METHOD.



		UNLESS OTHERWISE SPECIFIED DIMENSIONS ARE IN INCHES TOLERANCES ARE:	CONTRACT NO. ---		 WESTCOR a division of  VICOR Corp.
		FRACTIONS DECIMALS ANGLES ± --- ± .05 ± 3'	APPROVALS DATE		
		MATERIAL SEE NOTES	DRAWN M.E. ITURRALDE	12/26/96	IND COMMON MODE 70 $\mu$ H 80A
		FINISH ---	CHECKED L.KING	7/25/97	
---	SEE MIS		APPROVED R.B. DRABING	7/25/97	SIZE B
NEXT ASSY	USED ON		DESIGNED R.CABALLERO	12/03/96	CAGE CODE ---
APPLICATION		DO NOT SCALE DRAWING	DWG NO. 36-00029-06		REV C1
			SCALE NTS	FILENAME 36-00029-06.DWG	SHEET 1 OF 1