



POSEICO SPA
Power SEMiconductors Italian Corporation

POSEICO SPA
Via Pillea 42-44, 16153 Genova - ITALY
Tel. + 39 010 8599400 - Fax + 39 010 8682006
Sales Office:
Tel. + 39 010 8599400 - Fax + 39 010 8681180

FAST SWITCHING THYRISTOR

ATF527

Repetitive voltage up to **1400 V**
Mean on-state current **1230 A**
Surge current **15 kA**
Turn-off time **25 µs**

FINAL SPECIFICATION

apr 07 - ISSUE : 0

Symbol	Characteristic	Conditions	T _j [°C]	Value	Unit				
BLOCKING									
V _{RRM}	Repetitive peak reverse voltage		125	1400	V				
V _{RSM}	Non-repetitive peak reverse voltage		125	1500	V				
V _{DRM}	Repetitive peak off-state voltage		125	1400	V				
I _{RRM}	Repetitive peak reverse current	V=VRRM	125	65	mA				
I _{DRM}	Repetitive peak off-state current	V=VDRM	125	65	mA				
CONDUCTING									
I _{T(AV)}	Mean on-state current	180° sin, 50 Hz, Th=55°C, double side cooled		1230	A				
I _{T(AV)}	Mean on-state current	180° sin, 1 kHz, Th=55°C, double side cooled		1110	A				
I _{TSM}	Surge on-state current, non repetitive	sine wave, 10 ms	125	14,6	kA				
I ² t	I ² t	without reverse voltage		1066 x1E3	A ² s				
V _T	On-state voltage	On-state current = 2000 A	125	1,92	V				
V _{T(TO)}	Threshold voltage		125	1,40	V				
r _T	On-state slope resistance		125	0,260	mohm				
SWITCHING									
di/dt	Critical rate of rise of on-state current, min	From 75% VDRM up to 2000 A, gate 20V 10 ohm	125	800	A/µs				
dv/dt	Critical rate of rise of off-state voltage, min	Linear ramp up to 70% of VDRM	125	500	V/µs				
t _d	Gate controlled delay time, typical	VD=100V, gate source 20V, 10 ohm, tr=1 µs	25	1,5	µs				
t _q	Circuit commutated turn-off time	di/dt = 20 A/µs, I = 800 A dV/dt = 200 V/µs, up to 75% VDRM	125	25	µs				
Q _{rr}	Reverse recovery charge	di/dt = 60 A/µs, I = 1000 A	125	650	µC				
I _{rr}	Peak reverse recovery current	VR = 50 V		230	A				
I _H	Holding current, typical	VD=5V, gate open circuit	25	80	mA				
I _L	Latching current, typical	VD=5V, tp=30µs	25	230	mA				
GATE									
V _{GT}	Gate trigger voltage	VD=5V	25	3,5	V				
I _{GT}	Gate trigger current	VD=5V	25	350	mA				
V _{GD}	Non-trigger gate voltage, min.	VD=VDRM	125	0,25	V				
V _{FGM}	Peak gate voltage (forward)		25	30	V				
I _{FGM}	Peak gate current		25	10	A				
V _{RGM}	Peak gate voltage (reverse)		25	5	V				
P _{GM}	Peak gate power dissipation	Pulse width 100 µs	25	150	W				
P _{G(AV)}	Average gate power dissipation		25	3	W				
MOUNTING									
R _{th(j-h)}	Thermal impedance, DC	Junction to heatsink, double side cooled		26	°C/kW				
T _j	Operating junction temperature			-30 / 125	°C				
F	Mounting force			14.0 / 17.0	kN				
	Mass			500	g				
ORDERING INFORMATION : ATF527 S 14 M _____ tq code									
standard specification _____ VDRM&VRRM/100									
			tq code	D 10 µs	C 12 µs	B 15 µs	A 20 µs	L 25 µs	
				M 30 µs	N 35 µs	P 40 µs	R 45 µs	S 50 µs	
				T 60 µs	U 70 µs	W 80 µs	X 100µs	Y 150µs	

SWITCHING CHARACTERISTICS

REVERSE RECOVERY CHARGE
 $T_j = 125\text{ }^\circ\text{C}$

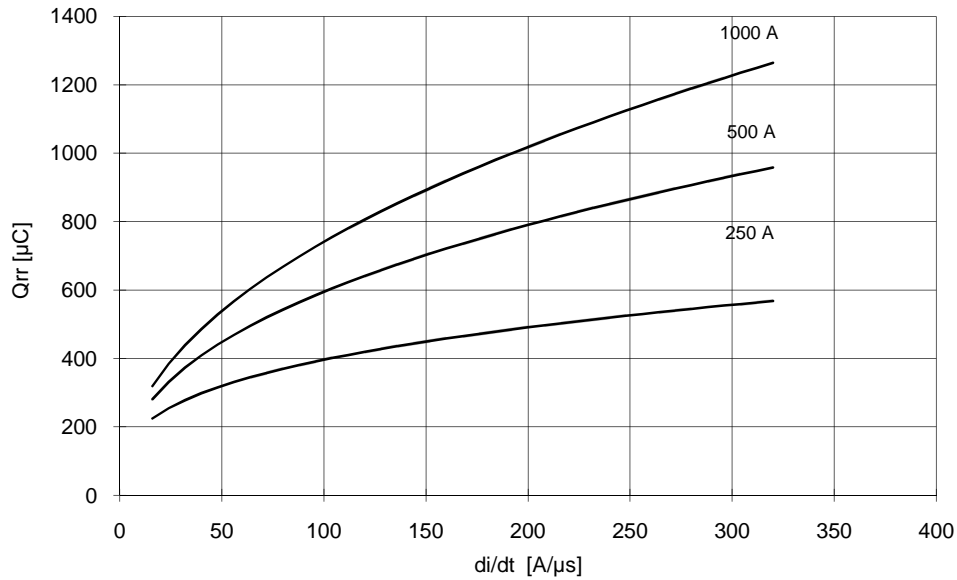

REVERSE RECOVERY CURRENT
 $T_j = 125\text{ }^\circ\text{C}$

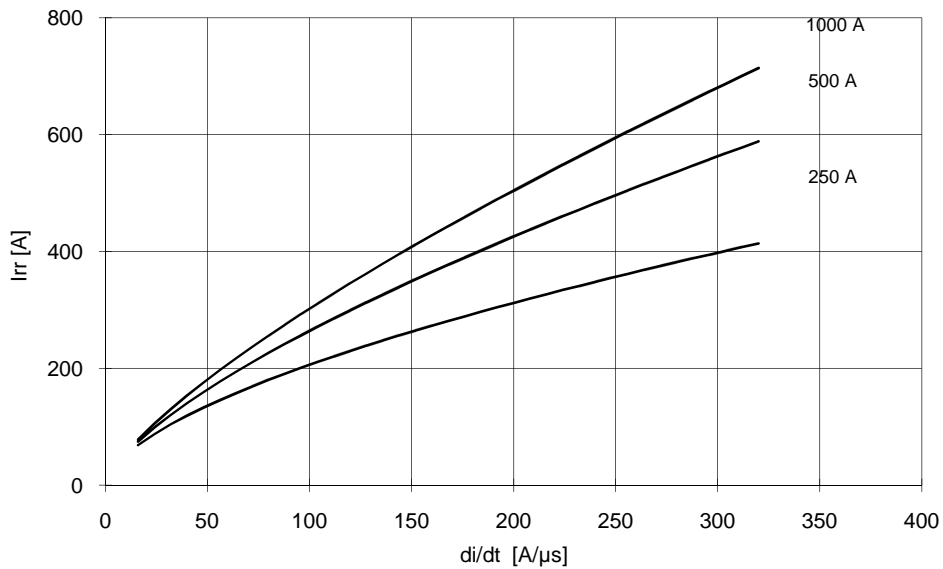

$$t_a = I_{rr} / (di/dt) \quad t_b = t_{rr} - t_a$$

$$\text{Softness (s factor)} \quad s = t_b / t_a$$

$$\text{Energy dissipation during recovery } E_r = V_r \cdot (Q_{rr} - I_{rr} \cdot t_a / 2)$$

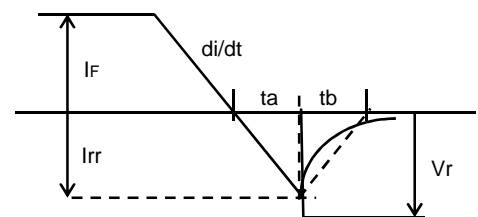

ATF527 FAST SWITCHING THYRISTOR

FINAL SPECIFICATION apr 07 - ISSUE : 0

ON-STATE CHARACTERISTIC
 $T_j = 125\text{ }^\circ\text{C}$

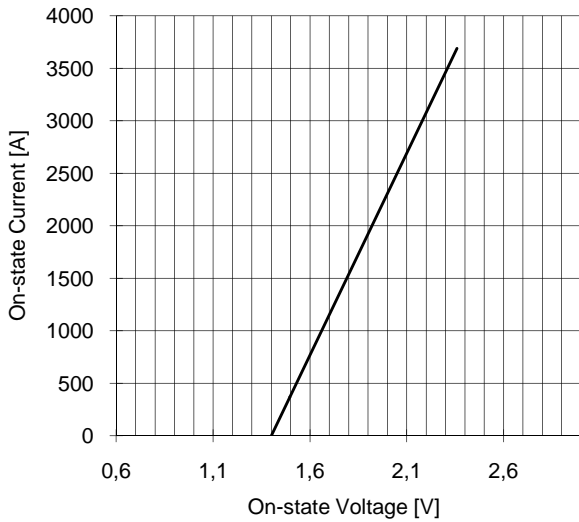

SURGE CHARACTERISTIC
 $T_j = 125\text{ }^\circ\text{C}$

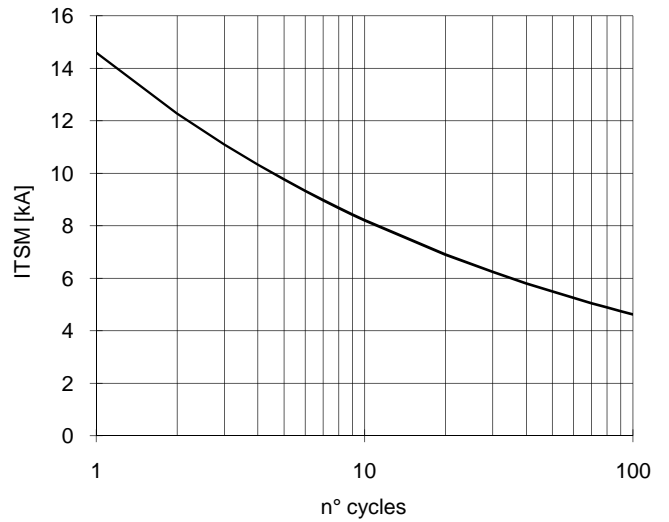

TRANSIENT THERMAL IMPEDANCE
 DOUBLE SIDE COOLED

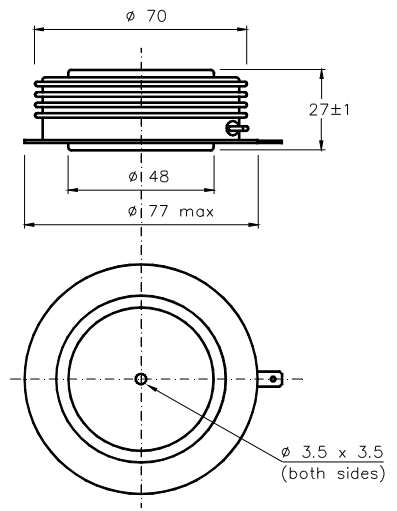
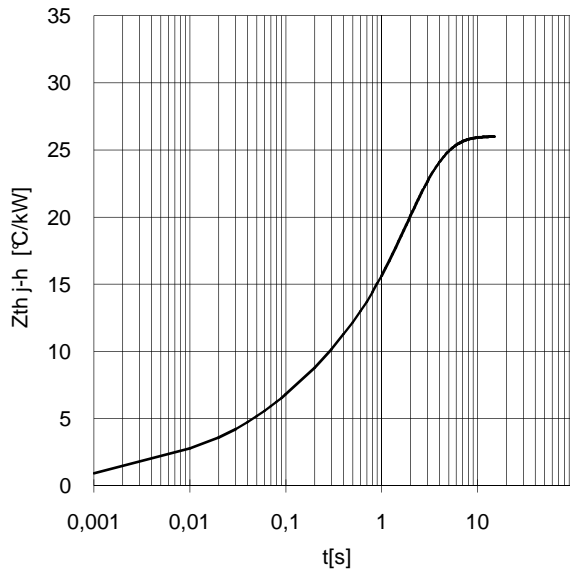

Cathode terminal type DIN 46244 - A 4.8 - 0.8
 Gate terminal type AMP 60598 - 1

All the characteristics given in this data sheet are guaranteed only with uniform clamping force, cleaned and lubricated heatsink, surfaces with flatness < .03 mm and roughness < 2 μm .
 In the interest of product improvement POSEICO S.p.A reserves the right to change any data given in this data sheet at any time without previous notice.
 If not stated otherwise the maximum value of ratings (symbols over shaded background) and characteristics is reported.

Distributed by

