

备注：
拧螺母，套垫圈。

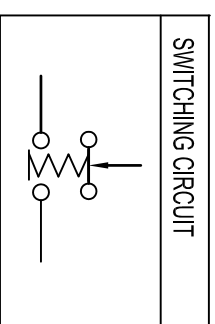

Nut Torque:5~14Nm
 Operating Pressure:350gf ±80gf
 Operating Stroke:3.0mm±0.3
 Protection Grade:IP65
 Function:ON-OFF
 Base:PA66
 Shell:SUS
 Button:SUS
 Rating:0.3A 12V DC/0.2A 24V DC
 0.1A 36V DC

Contact Resistance:50mΩ Max
 Insulation Resistance:100MΩ Min
 Dielectric Strength:1000V AC 1 minute
 Electrical life:50,000 cycles
 Mechanical life:100,000 cycles
 Operating Temperature:-20°C~80°C
 Relative Air Humidity:45%~85%
 Safety Approval: **RoHS**

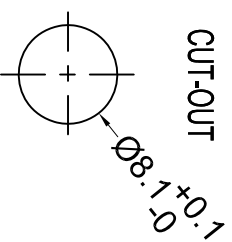
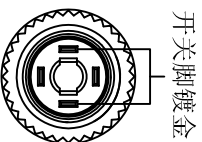
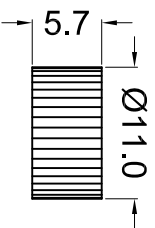
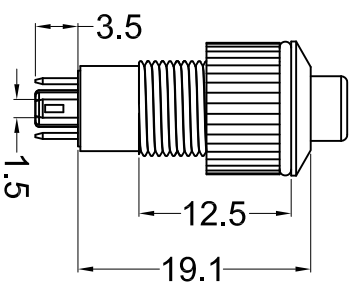
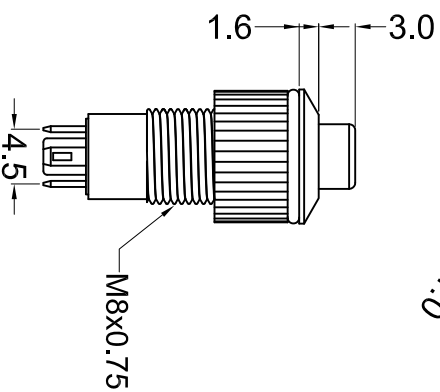

公差 TOLERANCES .X±0.5 .XX±0.3 角度 ANGLE ±1° 单位 DIMENSION UNIT mm.

版本 VER	变更说明 CHANGE DESCRIPTION	日期 DATE	ECON NO.	核准 APPROVED BY	核对 CHECKED BY	绘图 DRAWN BY	品名 TITLE	图号 DRAWING NO
				A0		孙成	PBM-8Z12-HT-N-NN-S7S-0005	1012896