

DS80EP100 5 to 12.5 Gbps, Power-Saver Equalizer for Backplanes and Cables

Check for Samples: [DS80EP100](#)

FEATURES

- 5 to 12.5 Gbps Operation
- No Power or Ground Required
- Equalization effective anywhere in data path
- Equalizes CML, LV-PECL, LVDS signals
- Symmetric I/O structures provide equal boost for bi-directional operation
- 7 dB Maximum Boost
- Code independent, 8b/10b or Scrambled
- Supports both bi-level and multi-level signaling
- Extends reach over backplanes and cables
- Compatible with PCI-Express Gen1 and Gen2
- Compatible with XAU1
- Will operate in series with existing active Equalizer
- Easy to handle 6 pin LLP

DESCRIPTION

National's Power-saver equalizer compensates for transmission medium losses and minimizes medium-induced deterministic jitter. Performance is guaranteed over the full range of 5 to 12.5 Gbps. The DS80EP100 requires no power to operate. The equalizer operates anywhere in the data path to minimize media-induced deterministic jitter in both FR4 traces and cable applications. Symmetric I/O structures support full duplex or half duplex applications. Linear compensation is provided independent of line coding or protocol. The device is ideal for both bi-level and multi-level signaling.

The equalizer is available in a 6 pin leadless LLP package with a space saving 2.2 mm X 2.5 mm footprint. This tiny package provides maximum flexibility in placement and routing of the Power-saver equalizer.

Simplified Application Diagram

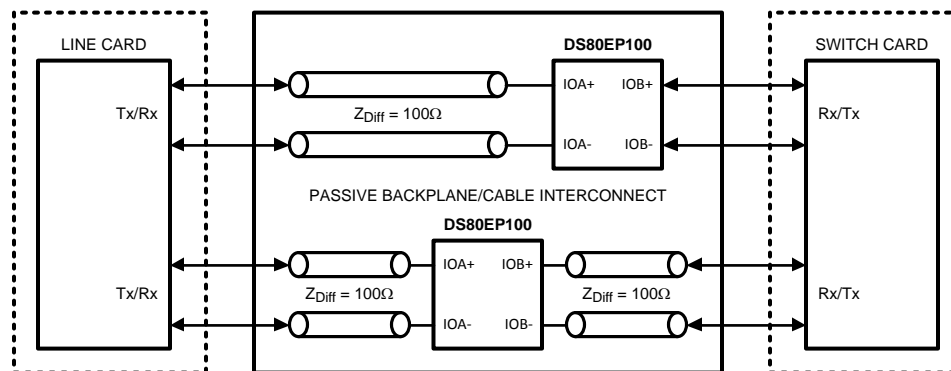

The DS80EP100 provides the flexibility of passing the data from either side of the device. It can be placed anywhere in the data path.

Pin Functions

Pin Descriptions

Pin Name	Pin Number	I/O Type	Description
High speed differential I/O			
IOA-	3	I/O	Symmetric differential I/O
IOA+	1		



Please be aware that an important notice concerning availability, standard warranty, and use in critical applications of Texas Instruments semiconductor products and disclaimers thereto appears at the end of this data sheet.

All trademarks are the property of their respective owners.

Pin Descriptions (continued)

Pin Name	Pin Number	I/O Type	Description
High speed differential I/O			
IOB- IOB+	4 6	I/O	Symmetric differential I/O
NC Exposed Pad	2, 5 DAP	N/A	Reserved. Do not connect.

Connection Diagram

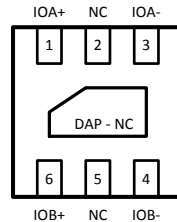

**Figure 1. Bottom View
2.2mm x 2.5mm 6-Pin LLP Package
Package Number SDA14A**



These devices have limited built-in ESD protection. The leads should be shorted together or the device placed in conductive foam during storage or handling to prevent electrostatic damage to the MOS gates.

Absolute Maximum Ratings ⁽¹⁾

INPUT/OUTPUT	
(IOA+ and IOB+) or (IOA- and IOB-)	+2V
(IOA+ and IOA-) or (IOB+ and IOB-)	+4V
(IOA+ and IOB-) or (IOA- and IOB+)	+4V
Junction Temperature	+150°C
Storage Temperature	-65°C to +150°C
Lead Temperature Soldering, 4 sec	+260°C
ESD Rating	
HBM, 1.5 kΩ, 100 pF	1.3kV

- (1) "Absolute Maximum Ratings" indicate limits beyond which damage to the device may occur, including inoperability and degradation of device reliability and/or performance. Functional operation of the device and/or non-degradation at the Absolute Maximum Ratings or other conditions beyond those indicated in the Recommended Operating Conditions is not implied. The Recommended Operating Conditions indicate conditions at which the device is functional and the device should not be operated beyond such conditions.

Recommended Operating Conditions

	Min	Typ	Max	Units
Ambient Temperature	-40	25	+85	°C
Bit Rate	5		12.5	Gbps

Electrical Characteristics ⁽¹⁾

Over recommended operating conditions unless other specified. All parameters are guaranteed by test, statistical analysis or design.

- (1) The Electrical Characteristics tables list guaranteed specifications under the listed Recommended Operating Conditions except as otherwise modified or specified by the Electrical Characteristics Conditions and/or Notes. Typical specifications are estimations only and are not guaranteed.

Electrical Characteristics ⁽¹⁾ (continued)

Over recommended operating conditions unless other specified. All parameters are guaranteed by test, statistical analysis or design.

Symbol	Parameter	Conditions	Min	Typ ⁽²⁾	Max	Units
V _{IN}	Input voltage swing	⁽³⁾		1000	3600	mVp-p
	Equalization	6.25 GHz relative to 100MHz		6		dB
R _{LI}	Differential input return loss	100 MHz – 6.25 GHz, with fixture's effect de-embedded		15		dB
R _{LO}	Differential output return loss	100 MHz – 6.25 GHz, with fixture's effect de-embedded IOA+, or IOB+ = static high.		15		dB
R _{IN}	Input Impedance	Differential across IOA+ and IOA-, or IOB+ and IOB-, ZLOAD = 100Ω		100		Ω
R _O	Output Impedance	Differential across IOA+ and IOA-, or IOB+ and IOB-, ZSOURCE = 100Ω		100		Ω
	Through Response	Relative to ideal load, see Figure 2 for setup	See Figure 3 and Table 1 for limits			
R1	Resistance IOA+ to IOA- and IOB+ to IOB-	No load, high impedance on all ports		150		Ω
R2	Resistance IOA+ to IOB+ and IOA- to IOB-	No load, high impedance on all ports		50		Ω
R3	Resistance IOA+ to IOB- and IOA- to IOB+	No load, high impedance on all ports		150		Ω
	DC Gain (IOA/IOB or IOB/IOA)	Z _{LOAD} = 100Ω		0.4		
DJ1	Residual deterministic jitter	5 Gbps, 20 in of 6mil microstrip FR4		0.15		Ulp-p
		See ⁽⁴⁾				
DJ2	Residual deterministic jitter	6.25 Gbps, 20 in of 6mil microstrip FR4		0.15	0.20	Ulp-p
		See ⁽⁴⁾ ⁽⁵⁾				
DJ3	Residual deterministic jitter	8 Gbps, 20 in of 6mil microstrip FR4		0.15	0.20	Ulp-p
		See ⁽⁴⁾ ⁽⁵⁾				
DJ4	Residual deterministic jitter	10 Gbps, 20 in of 6mil microstrip FR4 See ⁽⁴⁾		0.15		Ulp-p
DJ5	Residual deterministic jitter	12.5 Gbps, 14 in of 6mil microstrip FR4 See ⁽⁴⁾		0.15		Ulp-p

- (2) Typical values represent most likely parametric norms, TA = +25 degC, and at the Recommended Operation Conditions at the time of product characterization and are not guaranteed.
- (3) Differential signal to Equalizer, measured at the input to a transmission line, see point A of [Figure 2](#). The transmission line is Z₀ = 100Ω, 6-mil, microstrip in FR4 material.
- (4) Deterministic jitter is measured at the differential outputs (point C of [Figure 2](#)), minus the deterministic jitter before the test channel (point A of [Figure 2](#)). Test pattern: PRBS- 7 .
- (5) Specification is guaranteed by characterization and is not tested in production.

Test Setup Diagrams

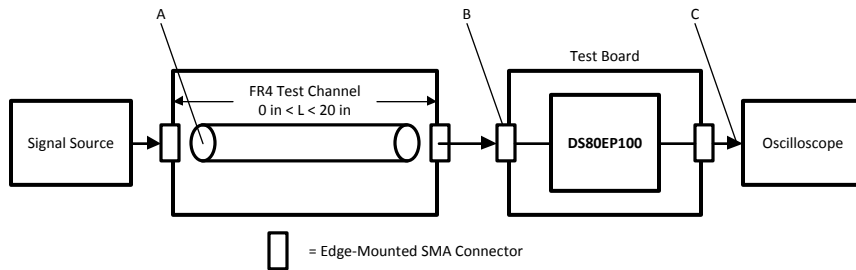

Figure 2. Transient Test Setup Diagram

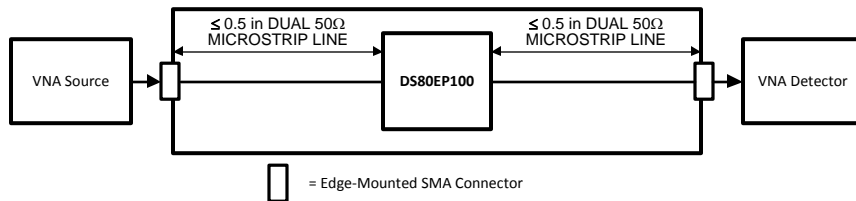

Figure 3. Frequency Response Test Circuit

Typical Equalizer Transfer Function

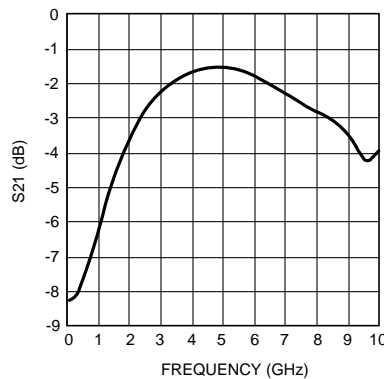

Figure 4. Typical Equalizer Transfer Function

Table 1. Table 1. Typical Through Response

Frequency (GHz)	DS80EP100 Attenuation Typ (dB)
0.1	-8.25
0.5	-7.64
1	-6.12
1.5	-4.68
2	-3.57
3	-2.22
4	-1.66
5	-1.53
6	-1.77
7	-2.28
8	-2.8
9	-3.47
10	-3.91

Block Diagram

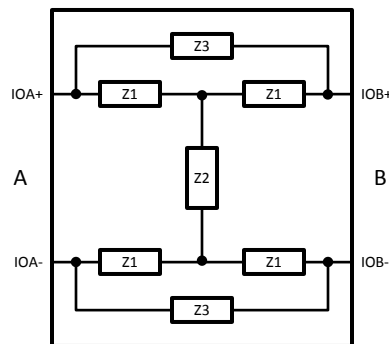

Figure 5. Simplified Block Diagram

Application Information

DS80EP100 DEVICE DESCRIPTION

The DS80EP100 Power-Saver equalizer is a passive network circuit composed of resistive, capacitive, and inductive components (See [Figure 5](#)). A Differential bridged T-network compensates for the transmission medium losses and minimizes medium-induced deterministic jitter with FR4 and cables. The equalizer attenuates low frequency signals and is a bandpass filter at the resonant frequency. The response is linear and symmetric.

I/O TERMINATIONS

The DS80EP100 I/O impedance is 100Ω differential. The equalizer is designed for 100Ω-balanced differential signals and is not intended for single-ended transmission.

LINEAR COMPENSATION

The unique linear compensation feature of the DS80EP100 combined with the tiny package allows maximum flexibility in placement. The equalizer can be placed anywhere in the data path and will provide the same compensation at the receiving circuit. (See Simplified Application Diagram)

SYMMETRIC I/O STRUCTURES

The symmetry of the passive equalization network allows bi-directional operation. Signals receive equal compensation regardless of the direction of data flow. (See Simplified Block Diagram).

PCB LAYOUT CONSIDERATIONS FOR DIFFERENTIAL PAIRS AND NO CONNECT PADS

The differential I/Os must have a controlled differential impedance of 100Ω . It is preferable to route all differential lines exclusively on one layer of the board. The use of vias should be avoided if possible. If vias must be used, they should be used sparingly and must be placed symmetrically for each side of a given differential pair. Differential signals should be routed away from other signals and noise sources on the printed circuit board. Pin 2, Pin 5, and the center DAP have to be left as no connect. Therefore, do not connect the landing pads of these pins to the power or ground plane. See AN-1187 for additional information on the LLP package.

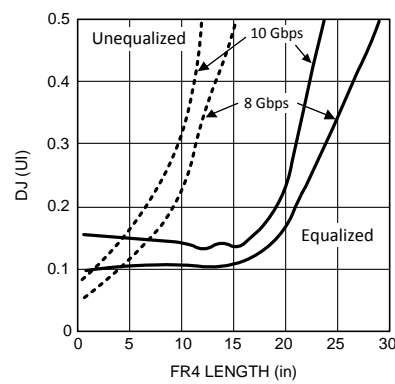

Figure 6. Residual Deterministic Jitter vs. FR4 Length

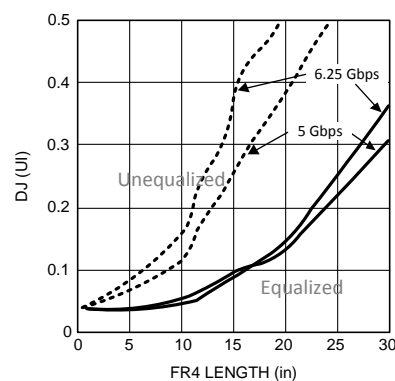

Figure 7. Residual Deterministic Jitter vs. FR4 Length

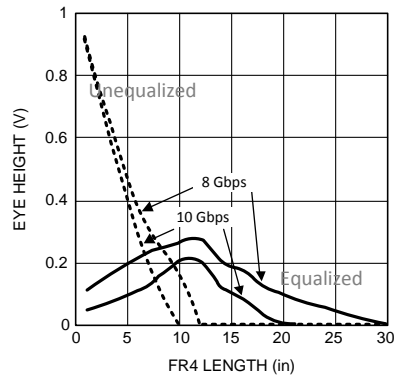

Figure 8. Eye Height vs. FR4 Length

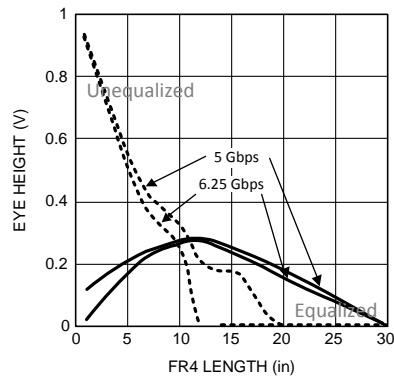
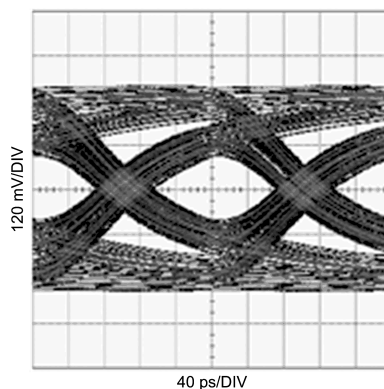
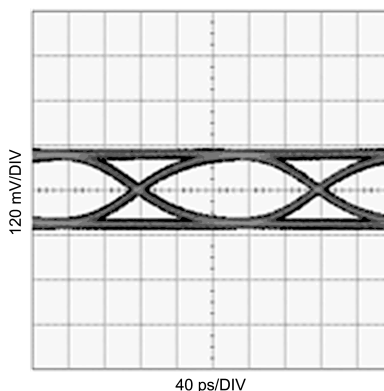
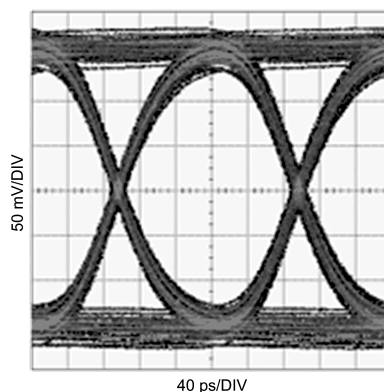

Figure 9. Eye Height vs. FR4 Length

Typical Eye Diagrams — Includes Transmitter Setup, Interconnect, and Device Total Jitter**Figure 10. Unequalized Signal (20in FR4, 5Gbps, PRBS7)****Figure 11. Equalized Signal (20in FR4, 5Gbps, PRBS7)****Figure 12. Equalized Signal (Zoom) (20in FR4, 5Gbps, PRBS7)**

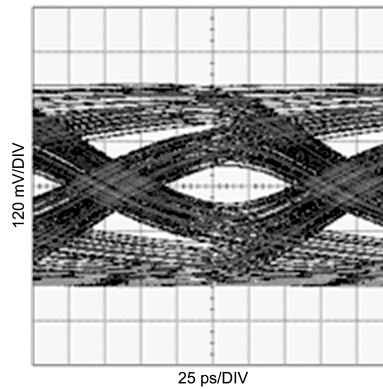

Figure 13. Unequalized Signal (20in FR4, 6.25Gbps, PRBS7)

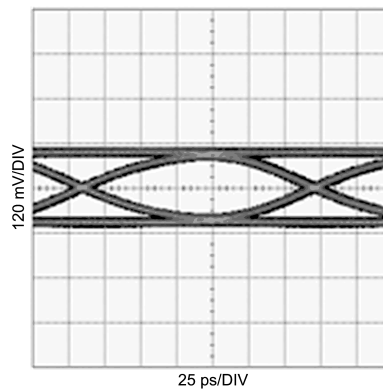

Figure 14. Equalized Signal (20in FR4, 6.25Gbps, PRBS7)

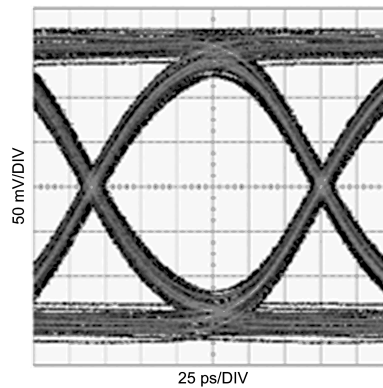

Figure 15. Equalized Signal (Zoom) (20in FR4, 6.26Gbps, PRBS7)

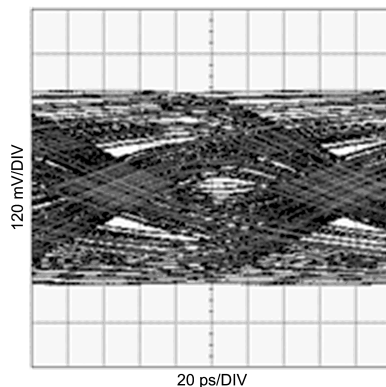

Figure 16. Unequalized Signal (20in FR4, 8Gbps, PRBS7)

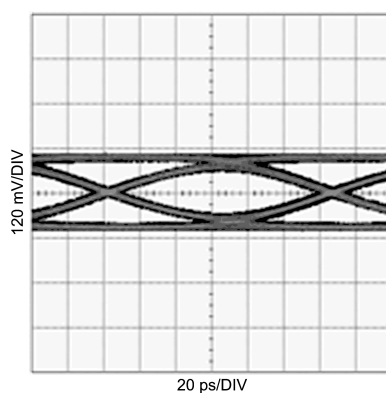

Figure 17. Equalized Signal (20in FR4, 8Gbps, PRBS7)

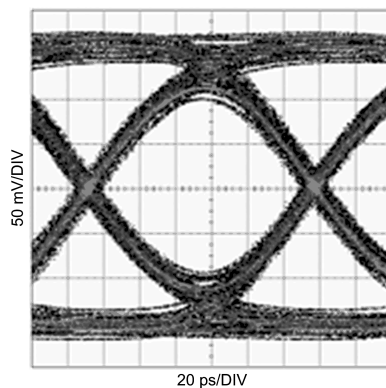

Figure 18. Equalized Signal (Zoom) (20in FR4, 8Gbps, PRBS7)

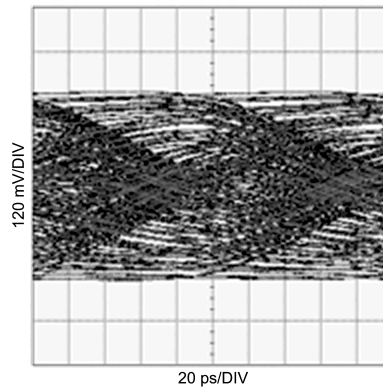

Figure 19. Unequalized Signal (20in FR4, 10Gbps, PRBS7)

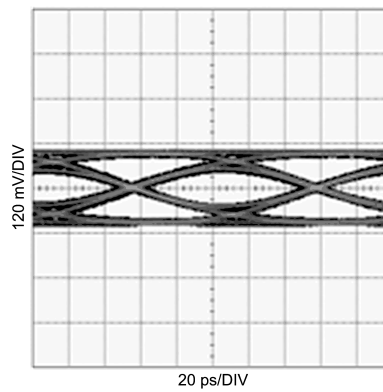

Figure 20. Equalized Signal (20in FR4, 10Gbps, PRBS7)

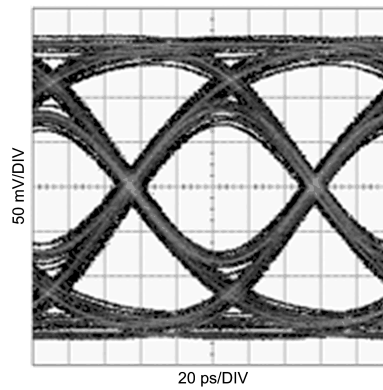

Figure 21. Equalized Signal (Zoom) (20in FR4, 10Gbps, PRBS7)

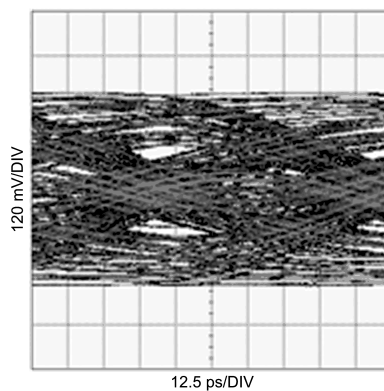

Figure 22. Unequalized Signal (14in FR4, 12.5Gbps, PRBS7)

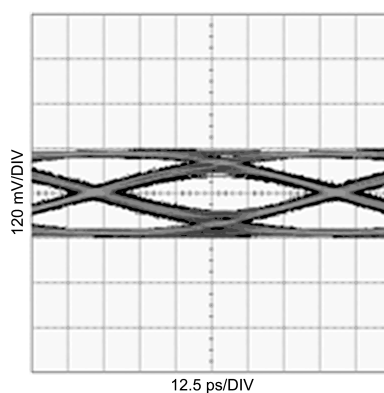

Figure 23. Equalized Signal (14in FR4, 12.5Gbps, PRBS7)

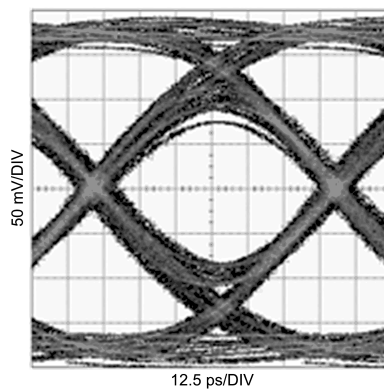

Figure 24. Equalized Signal (Zoom) (14in FR4, 12.5Gbps, PRBS7)

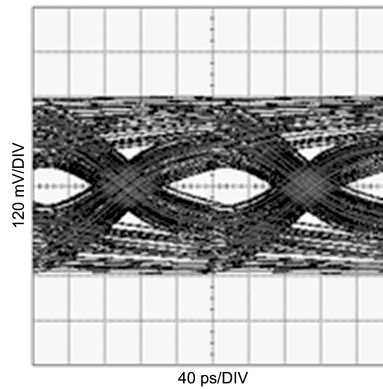

Figure 25. Unequalized Signal (5m 26AWG Twin-AX Cable, 5Gbps, PRBS7)

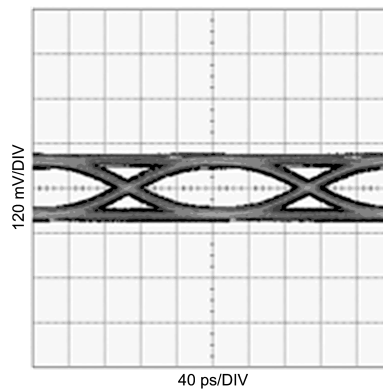

Figure 26. Equalized Signal (5m 26AWG Twin-AX Cable, 5Gbps, PRBS7)

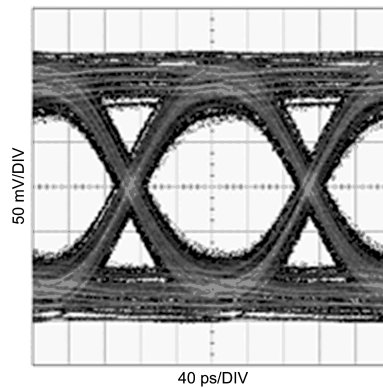

Figure 27. Equalized Signal (Zoom) (5m 26AWG Twin-AX Cable, 5Gbps, PRBS7)

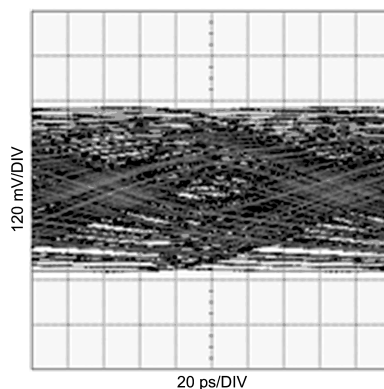

Figure 28. Unequalized Signal (5m 26AWG Twin-AX Cable, 8Gbps, PRBS7)

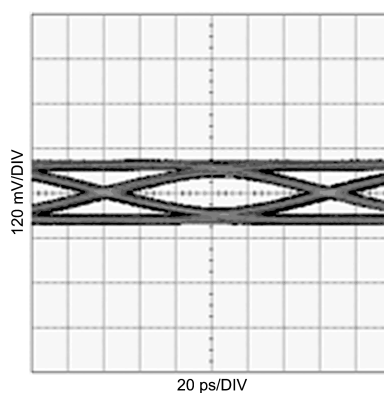

Figure 29. Equalized Signal (5m 26AWG Twin-AX Cable, 8Gbps, PRBS7)

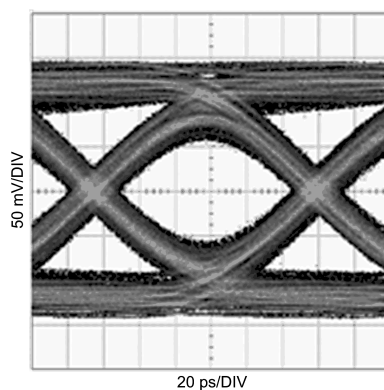

Figure 30. Equalized Signal (Zoom) (5m 26AWG Twin-AX Cable, 8Gbps, PRBS7)

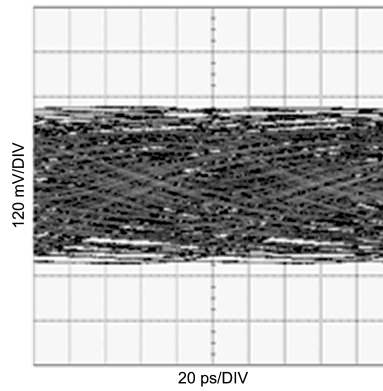

Figure 31. Unequalized Signal (5m 26AWG Twin-AX Cable, 10Gbps, PRBS7)

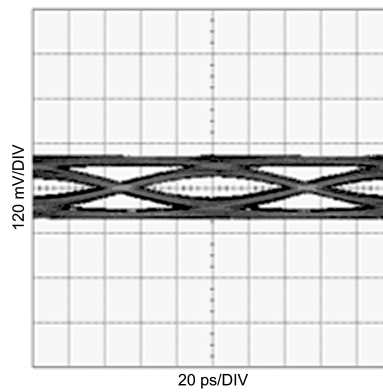

Figure 32. Equalized Signal (5m 26AWG Twin-AX Cable, 10Gbps, PRBS7)

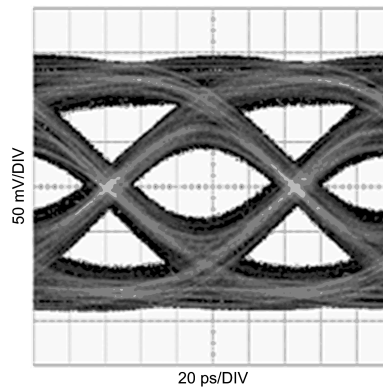

Figure 33. Equalized Signal (Zoom) (5m 26AWG Twin-AX Cable, 10Gbps, PRBS7)

PACKAGING INFORMATION

Orderable Device	Status (1)	Package Type	Package Drawing	Pins	Package Qty	Eco Plan (2)	Lead/Ball Finish	MSL Peak Temp (3)	Samples (Requires Login)
DS80EP100SD/NOPB	ACTIVE	WSON	NGF	6	1000	Green (RoHS & no Sb/Br)	CU SN	Level-1-260C-UNLIM	
DS80EP100SDX/NOPB	ACTIVE	WSON	NGF	6	4500	Green (RoHS & no Sb/Br)	CU SN	Level-1-260C-UNLIM	

(1) The marketing status values are defined as follows:

ACTIVE: Product device recommended for new designs.

LIFEBUY: TI has announced that the device will be discontinued, and a lifetime-buy period is in effect.

NRND: Not recommended for new designs. Device is in production to support existing customers, but TI does not recommend using this part in a new design.

PREVIEW: Device has been announced but is not in production. Samples may or may not be available.

OBSELETE: TI has discontinued the production of the device.

(2) Eco Plan - The planned eco-friendly classification: Pb-Free (RoHS), Pb-Free (RoHS Exempt), or Green (RoHS & no Sb/Br) - please check <http://www.ti.com/productcontent> for the latest availability information and additional product content details.

TBD: The Pb-Free/Green conversion plan has not been defined.

Pb-Free (RoHS): TI's terms "Lead-Free" or "Pb-Free" mean semiconductor products that are compatible with the current RoHS requirements for all 6 substances, including the requirement that lead not exceed 0.1% by weight in homogeneous materials. Where designed to be soldered at high temperatures, TI Pb-Free products are suitable for use in specified lead-free processes.

Pb-Free (RoHS Exempt): This component has a RoHS exemption for either 1) lead-based flip-chip solder bumps used between the die and package, or 2) lead-based die adhesive used between the die and leadframe. The component is otherwise considered Pb-Free (RoHS compatible) as defined above.

Green (RoHS & no Sb/Br): TI defines "Green" to mean Pb-Free (RoHS compatible), and free of Bromine (Br) and Antimony (Sb) based flame retardants (Br or Sb do not exceed 0.1% by weight in homogeneous material)

(3) MSL, Peak Temp. -- The Moisture Sensitivity Level rating according to the JEDEC industry standard classifications, and peak solder temperature.

Important Information and Disclaimer: The information provided on this page represents TI's knowledge and belief as of the date that it is provided. TI bases its knowledge and belief on information provided by third parties, and makes no representation or warranty as to the accuracy of such information. Efforts are underway to better integrate information from third parties. TI has taken and continues to take reasonable steps to provide representative and accurate information but may not have conducted destructive testing or chemical analysis on incoming materials and chemicals. TI and TI suppliers consider certain information to be proprietary, and thus CAS numbers and other limited information may not be available for release.

In no event shall TI's liability arising out of such information exceed the total purchase price of the TI part(s) at issue in this document sold by TI to Customer on an annual basis.

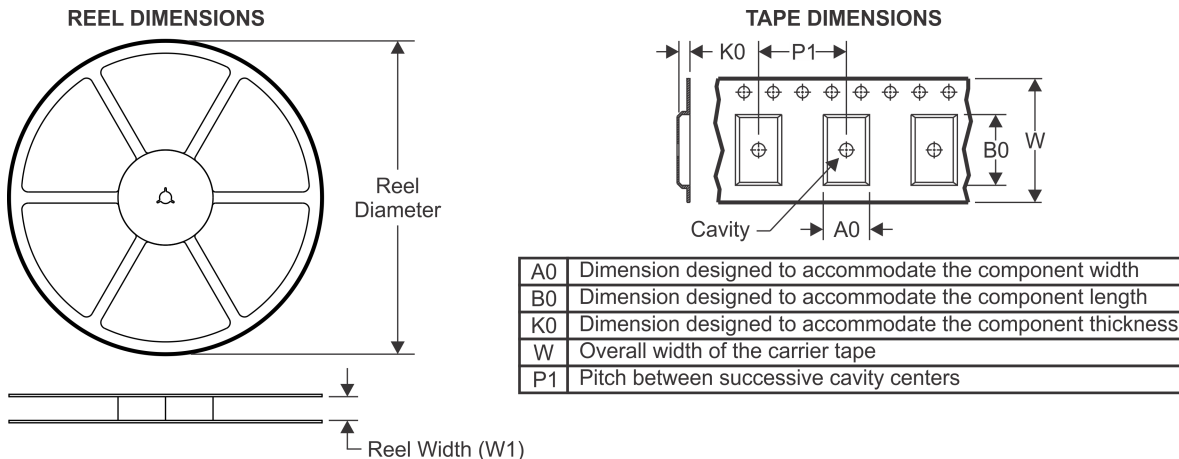
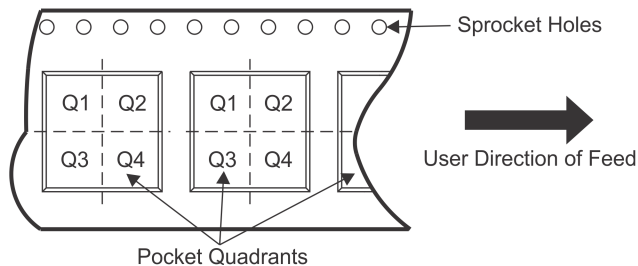
TAPE AND REEL INFORMATION

QUADRANT ASSIGNMENTS FOR PIN 1 ORIENTATION IN TAPE

*All dimensions are nominal

Device	Package Type	Package Drawing	Pins	SPQ	Reel Diameter (mm)	Reel Width W1 (mm)	A0 (mm)	B0 (mm)	K0 (mm)	P1 (mm)	W (mm)	Pin1 Quadrant
DS80EP100SD/NOPB	WSON	NGF	6	1000	178.0	12.4	2.8	2.5	1.0	8.0	12.0	Q1
DS80EP100SDX/NOPB	WSON	NGF	6	4500	330.0	12.4	2.8	2.5	1.0	8.0	12.0	Q1

TAPE AND REEL BOX DIMENSIONS



*All dimensions are nominal

Device	Package Type	Package Drawing	Pins	SPQ	Length (mm)	Width (mm)	Height (mm)
DS80EP100SD/NOPB	WSON	NGF	6	1000	203.0	190.0	41.0
DS80EP100SDX/NOPB	WSON	NGF	6	4500	349.0	337.0	45.0

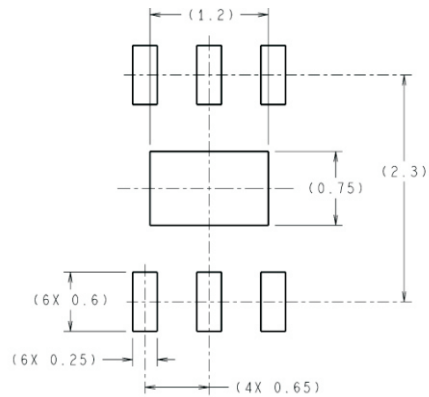
NGF0006A

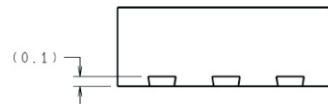

DIMENSIONS ARE IN MILLIMETERS
DIMENSIONS IN () FOR REFERENCE ONLY



RECOMMENDED LAND PATTERN

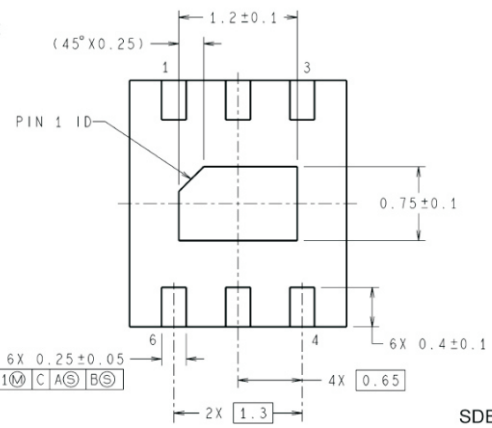
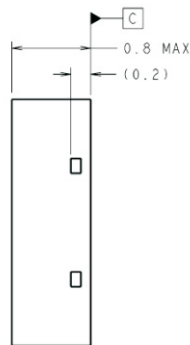
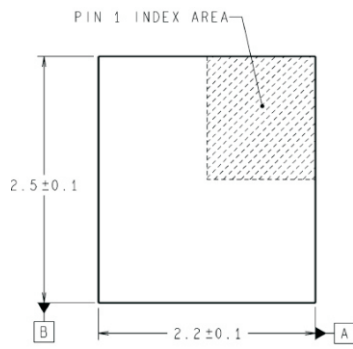

SDB06A (Rev A)

IMPORTANT NOTICE

Texas Instruments Incorporated and its subsidiaries (TI) reserve the right to make corrections, enhancements, improvements and other changes to its semiconductor products and services per JESD46, latest issue, and to discontinue any product or service per JESD48, latest issue. Buyers should obtain the latest relevant information before placing orders and should verify that such information is current and complete. All semiconductor products (also referred to herein as "components") are sold subject to TI's terms and conditions of sale supplied at the time of order acknowledgment.

TI warrants performance of its components to the specifications applicable at the time of sale, in accordance with the warranty in TI's terms and conditions of sale of semiconductor products. Testing and other quality control techniques are used to the extent TI deems necessary to support this warranty. Except where mandated by applicable law, testing of all parameters of each component is not necessarily performed.

TI assumes no liability for applications assistance or the design of Buyers' products. Buyers are responsible for their products and applications using TI components. To minimize the risks associated with Buyers' products and applications, Buyers should provide adequate design and operating safeguards.

TI does not warrant or represent that any license, either express or implied, is granted under any patent right, copyright, mask work right, or other intellectual property right relating to any combination, machine, or process in which TI components or services are used. Information published by TI regarding third-party products or services does not constitute a license to use such products or services or a warranty or endorsement thereof. Use of such information may require a license from a third party under the patents or other intellectual property of the third party, or a license from TI under the patents or other intellectual property of TI.

Reproduction of significant portions of TI information in TI data books or data sheets is permissible only if reproduction is without alteration and is accompanied by all associated warranties, conditions, limitations, and notices. TI is not responsible or liable for such altered documentation. Information of third parties may be subject to additional restrictions.

Resale of TI components or services with statements different from or beyond the parameters stated by TI for that component or service voids all express and any implied warranties for the associated TI component or service and is an unfair and deceptive business practice. TI is not responsible or liable for any such statements.

Buyer acknowledges and agrees that it is solely responsible for compliance with all legal, regulatory and safety-related requirements concerning its products, and any use of TI components in its applications, notwithstanding any applications-related information or support that may be provided by TI. Buyer represents and agrees that it has all the necessary expertise to create and implement safeguards which anticipate dangerous consequences of failures, monitor failures and their consequences, lessen the likelihood of failures that might cause harm and take appropriate remedial actions. Buyer will fully indemnify TI and its representatives against any damages arising out of the use of any TI components in safety-critical applications.

In some cases, TI components may be promoted specifically to facilitate safety-related applications. With such components, TI's goal is to help enable customers to design and create their own end-product solutions that meet applicable functional safety standards and requirements. Nonetheless, such components are subject to these terms.

No TI components are authorized for use in FDA Class III (or similar life-critical medical equipment) unless authorized officers of the parties have executed a special agreement specifically governing such use.

Only those TI components which TI has specifically designated as military grade or "enhanced plastic" are designed and intended for use in military/aerospace applications or environments. Buyer acknowledges and agrees that any military or aerospace use of TI components which have **not** been so designated is solely at the Buyer's risk, and that Buyer is solely responsible for compliance with all legal and regulatory requirements in connection with such use.

TI has specifically designated certain components as meeting ISO/TS16949 requirements, mainly for automotive use. In any case of use of non-designated products, TI will not be responsible for any failure to meet ISO/TS16949.

Products

Audio	www.ti.com/audio
Amplifiers	amplifier.ti.com
Data Converters	dataconverter.ti.com
DLP® Products	www.dlp.com
DSP	dsp.ti.com
Clocks and Timers	www.ti.com/clocks
Interface	interface.ti.com
Logic	logic.ti.com
Power Mgmt	power.ti.com
Microcontrollers	microcontroller.ti.com
RFID	www.ti-rfid.com
OMAP Applications Processors	www.ti.com/omap
Wireless Connectivity	www.ti.com/wirelessconnectivity

Applications

Automotive and Transportation	www.ti.com/automotive
Communications and Telecom	www.ti.com/communications
Computers and Peripherals	www.ti.com/computers
Consumer Electronics	www.ti.com/consumer-apps
Energy and Lighting	www.ti.com/energy
Industrial	www.ti.com/industrial
Medical	www.ti.com/medical
Security	www.ti.com/security
Space, Avionics and Defense	www.ti.com/space-avionics-defense
Video and Imaging	www.ti.com/video

TI E2E Community

e2e.ti.com

Mouser Electronics

Authorized Distributor

Click to View Pricing, Inventory, Delivery & Lifecycle Information:

[Texas Instruments:](#)

[DS80EP100-EVK](#)