



MK NAND FLASH Product Datasheet

Product List

MKPV64G08CT-MLA
8GB NAND Flash

<http://www.mkfounder.com>



Revision History

Version	Date	Description
Rev 1.0	2021/4/24	Original version

MK FOUNFER CONFIDENTIAL

Notice :

The datasheet is prepared and approved by MK Founder semiconductor co., LTD.

MK Founder reserves the right to change products or specifications without notice.

©2021 MK Founder semiconductor co., LTD. All rights reserved.



Table Of Contents

1 Introduction	- 6 -
2 Features	- 6 -
3 Asynchronous and Synchronous Signal Descriptions	- 8 -
4 Signal Assignments	- 9 -
5 Package Dimensions	- 10 -
6 Architecture	- 11 -
7 Device and Array Organization	- 12 -
8 Bus Operation – Asynchronous Interface	- 14 -
8.1 Asynchronous Enable/Standby	- 14 -
8.2 Asynchronous Bus Idle	- 15 -
8.3 Asynchronous Commands	- 15 -
8.4 Asynchronous Addresses	- 15 -
8.5 Asynchronous Data Input	- 16 -
8.6 Asynchronous Data Output	- 17 -
9 Write Protect	- 18 -
10 Ready/Busy#	- 18 -
11 Bus Operation – Synchronous Interface	- 22 -
11.1 Synchronous Enable/Standby	- 24 -
11.2 Synchronous Bus Idle/Driving	- 24 -
11.3 Synchronous Commands	- 25 -
11.4 Synchronous Addresses	- 26 -
11.5 Synchronous DDR Data Input	- 28 -
11.6 Synchronous DDR Data Output	- 29 -
12 Device Initialization	- 31 -
13 Activating Interfaces	- 32 -
13.1 Activating the Asynchronous Interface	- 32 -
13.2 Activating the Synchronous Interface	- 32 -
14 Command Definitions	- 33 -
15 Reset Operations	- 36 -
15.1 RESET (FFh)	- 36 -
15.2 SYNCHRONOUS RESET (FCh)	- 37 -
15.3 RESET LUN (FAh)	- 37 -
16 Identification Operations	- 38 -
16.1 READ ID (90h)	- 38 -
16.2 READ ID Parameter Tables	- 40 -
16.3 READ PARAMETER PAGE (ECh)	- 41 -
16.4 READ UNIQUE ID (EDh)	- 51 -
17 Configuration Operations	- 52 -
17.1 SET FEATURES (EFh)	- 53 -



17.2 GET FEATURES (EEh).....	- 54 -
18 Status Operations	- 58 -
18.1 READ STATUS (70h).....	- 60 -
18.2 READ STATUS ENHANCED (78h).....	- 61 -
19 Column Address Operations	- 62 -
19.1 CHANGE READ COLUMN (05h-E0h).....	- 62 -
19.2 CHANGE READ COLUMN ENHANCED (06h-E0h).....	- 63 -
19.3 CHANGE WRITE COLUMN (85h).....	- 64 -
19.4 CHANGE ROW ADDRESS (85h).....	- 65 -
20 Read Operations	- 66 -
20.1 READ MODE (00h).....	- 68 -
20.2 READ PAGE (00h-30h).....	- 69 -
20.3 READ PAGE CACHE SEQUENTIAL (31h).....	- 70 -
20.4 READ PAGE CACHE RANDOM (00h-31h).....	- 71 -
20.5 READ PAGE CACHE LAST (3Fh).....	- 72 -
20.6 READ PAGE MULTI-PLANE (00h-32h).....	- 74 -
21 Read Retry Operations	- 75 -
22 Program Operations	- 77 -
22.1 PROGRAM PAGE (80h-10h).....	- 78 -
22.2 PROGRAM PAGE CACHE (80h-15h).....	- 79 -
22.3 PROGRAM PAGE MULTI-PLANE (80h-11h).....	- 81 -
23 Erase Operations	- 82 -
23.1 ERASE BLOCK (60h-D0h).....	- 82 -
23.2 ERASE BLOCK MULTI-PLANE (60h-D1h).....	- 83 -
23.3 ERASE BLOCK MULTI-PLANE (60h-60h-D0h).....	- 84 -
24 Copyback Operations	- 84 -
24.1 COPYBACK READ (00h-35h).....	- 85 -
24.2 COPYBACK PROGRAM (85h-10h).....	- 86 -
24.3 COPYBACK READ MULTI-PLANE (00h-32h).....	- 87 -
24.4 COPYBACK PROGRAM MULTI-PLANE (85h-11h).....	- 87 -
25 One-Time Programmable (OTP) Operations	- 88 -
25.1 PROGRAM OTP PAGE (80h-10h).....	- 89 -
25.2 PROTECT OTP AREA (80h-10h).....	- 90 -
25.3 READ OTP PAGE (00h-30h).....	- 91 -
26 Multi-Plane Operations	- 92 -
26.1 Multi-Plane Addressing	- 92 -
27 Interleaved Die (Multi-LUN) Operations	- 93 -
28 Error Management	- 94 -
29 Shared Pages	- 95 -
30 Output Drive Impedance	- 97 -
31 AC Overshoot/Undershoot Specifications	- 100 -
32 Synchronous Input Slew Rate	- 102 -
33 Output Slew Rate	- 103 -



34 Power Cycle Requirements - 103 -

35 Electrical Specifications - 105 -

36 Electrical Specifications - 107 -

(Asynchronous) - 107 -

37 Electrical Specifications - 107 -

38 Electrical Specifications - 108 -

(VCCQ) - 108 -

39 Electrical Specifications - 109 -

40 Electrical Specifications - 112 -

41 Electrical Specifications – Array Characteristics - 114 -

 41.1 Asynchronous Interface Timing Diagrams - 115 -

42 Synchronous Interface Timing Diagrams - 126 -

MK FOUNFER CONFIDENTIAL



1 Introduction

MK Founder NAND Flash devices include an asynchronous data interface for high-performance I/O operations. These devices use a highly multiplexed 8-bit bus (DQx) to transfer commands, address, and data. There are five control signals used to implement the asynchronous data interface: CE#, CLE, ALE, WE#, and RE#. Additional signals control hardware write protection (WP#) and monitor device status (R/B#).

This NAND Flash device additionally includes a synchronous data interface for high-performance I/O operations. When the synchronous interface is active, WE# becomes CLK and RE# becomes W/R#. Data transfers include a bidirectional data strobe (DQS).

This hardware interface creates a low pin-count device with a standard pinout that remains the same from one density to another, enabling future upgrades to higher densities with no board redesign.

A target is the unit of memory accessed by a chip enable signal. A NAND Flash die is the minimum unit that can independently execute commands and report status. A NAND Flash die, in the ONFI specification, is referred to as a logical unit (LUN).

2 Features

- Open NAND Flash Interface (ONFI) 2.3-compliant
- Multiple-level cell (MLC) technology
- Organization
 - Page size x8: 8936 bytes (8192 + 744 bytes)
 - Block size: 256 pages (2048K + 186K bytes)
 - Plane size: 2 planes x 2048 blocks per plane
 - Device size: 64Gb: 4096 blocks
- Synchronous I/O performance
 - Up to synchronous timing mode 52
 - Clock rate: 10ns (DDR)
 - Read/write throughput per pin: 200 MT/s
- Asynchronous I/O performance
 - Up to asynchronous timing mode 5
 - tRC/tWC: 20ns (MIN)
- Array performance
 - Read page: 75µs (MAX)
 - Program page: 1300µs (TYP)
 - Erase block: 3ms (TYP)
- Operating Voltage Range



- VCC: 2.7–3.6V
- VCCQ: 1.7–1.95V, 2.7–3.6V
- Command set: ONFI NAND Flash Protocol
- Advanced Command Set
 - Program cache
 - Read cache sequential
 - Read cache random
 - One-time programmable (OTP) mode
 - Multi-plane commands
 - Multi-LUN operations
 - Read unique ID
 - Copyback
- First block (block address 00h) is valid when shipped from factory. For minimum required ECC, see Error Management (page 110).
- RESET (FFh) required as first command after power on

- Operation status byte provides software method for detecting
 - Operation completion
 - Pass/fail condition
 - Write-protect status
- Data strobe (DQS) signals provide a hardware method for synchronizing data DQ in the synchronous interface
- Copyback operations supported within the plane from which data is read
- Quality and reliability
 - Data retention: JESD47G compliant; see qualification report
 - Endurance: 3000 PROGRAM/ERASE cycles
- Operating temperature:
 - Commercial: 0°C to +70°C
- Package
 - 48-pin TSOP



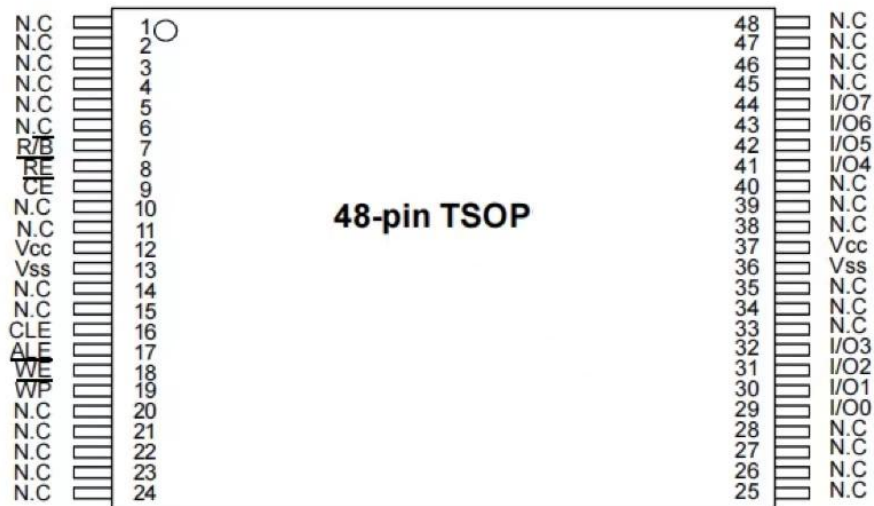
3 Asynchronous and Synchronous Signal Descriptions

Table 1: Asynchronous and Synchronous Signal Definitions

Signal	Type	Description
ALE	Input	Address latch enable: Loads an address from DQx into the address register.
CE#	Input	Chip enable: Enables or disables one or more die (LUNs) in a target1.
CLE	Input	Command latch enable: Loads a command from DQx into the command register.
RE#	Input	Read enable and write/read: RE# transfers serial data from the NAND Flash to the host system when the asynchronous interface is active. When the synchronous interface is active, W/R# controls the direction of DQx and DQS.
WE#	Input	Write enable and clock: WE# transfers commands, addresses, and serial data from the host system to the NAND Flash when the asynchronous interface is active. When the synchronous interface is active, CLK latches command and address cycles.
WP#	Input	Write protect: Enables or disables array PROGRAM and ERASE operations.
R/B#	Output	Ready/busy: An open-drain, active-low output that requires an external pull-up resistor. This signal indicates target array activity.
VCC	Supply	VCC: Core power supply
VSS	Supply	VSS: Core ground connection
NC	–	No connect: NCs are not internally connected. They can be driven or left unconnected.

4 Signal Assignments

Figure 2: 48-Pin TSOP

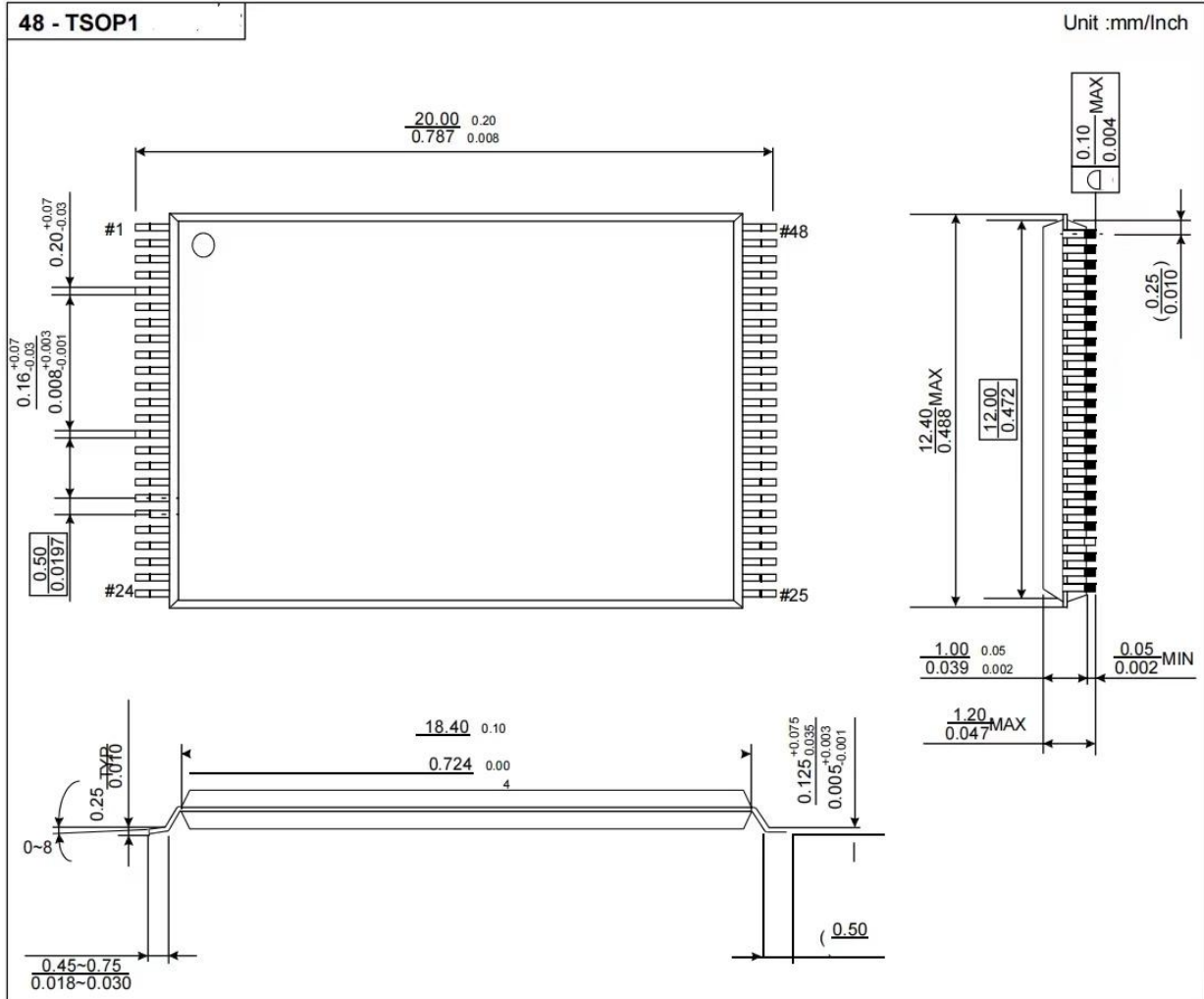


MK FOUNFER



5 Package Dimensions

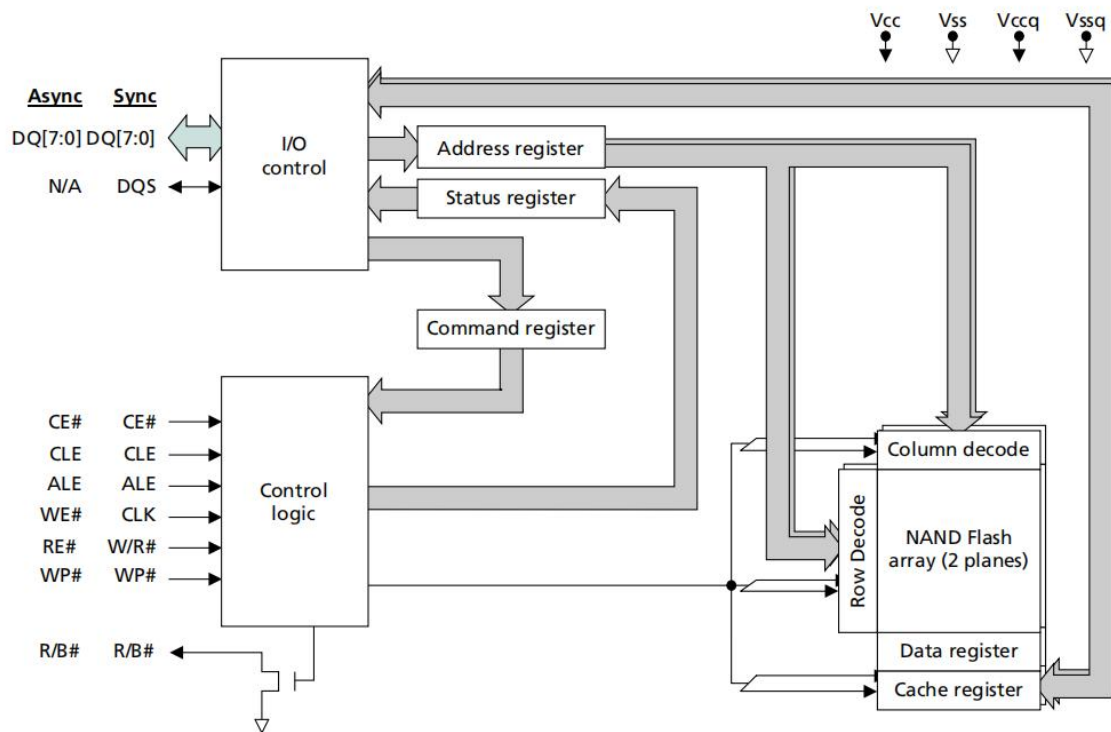
Figure 3: 48-Pin TSOP



6 Architecture

These devices use NAND Flash electrical and command interfaces. Data, commands, and addresses are multiplexed onto the same pins and received by I/O control circuits. The commands received at the I/O control circuits are latched by a command register and are transferred to control logic circuits for generating internal signals to control device operations. The addresses are latched by an address register and sent to a row decoder to select a row address, or to a column decoder to select a column address. Data is transferred to or from the NAND Flash memory array, byte by byte, through a data register and a cache register. The NAND Flash memory array is programmed and read using page-based operations and is erased using block-based operations. During normal page operations, the data and cache registers act as a single register. During cache operations, the data and cache registers operate independently to increase data throughput. The status register reports the status of die (LUN) operations.

Figure 4: NAND Flash Die (LUN) Functional Block Diagram



- Notes: 1. N/A: This signal is tri-stated when the asynchronous interface is active.
 2. Some devices do not include the synchronous interface.

7 Device and Array Organization

Figure 5: Device Organization for Single-Die Package (TSOP/BGA)

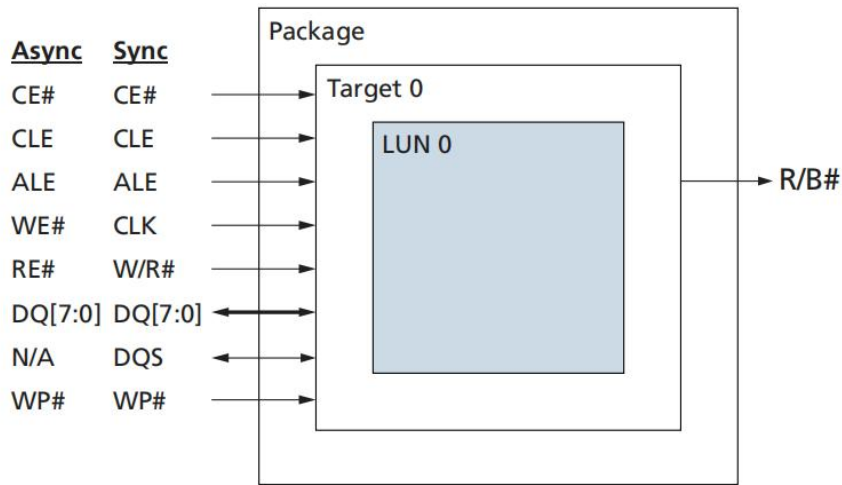


Figure 6: Array Organization per Logical Unit (LUN)

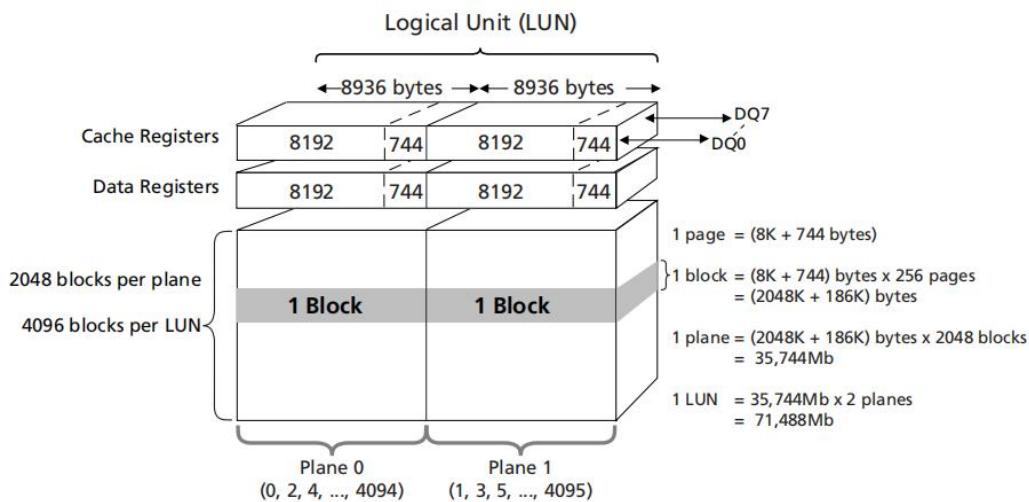


Table 2: Array Addressing for Logical Unit (LUN)



Cycle	DQ7	DQ6	DQ5	DQ4	DQ3	DQ2	DQ1	DQ0
First	CA7	CA6	CA5	CA4	CA3	CA2	CA1	CA0 ²
Second	LOW	LOW	CA13 ³	CA12	CA11	CA10	CA9	CA8
Third	PA7	PA6	PA5	PA4	PA3	PA2	PA1	PA0
Fourth	BA15	BA14	BA13	BA12	BA11	BA10	BA9	BA8 ⁴
Fifth	LOW	LOW	LOW	LA0 ⁵	BA19	BA18	BA17	BA16

Notes:

1. CAx = column address, PAx = page address, BAx = block address, LAx = LUN address; the page address, block address, and LUN address are collectively called the row address.
2. When using the synchronous interface, CA0 is forced to 0 internally; one data cycle always returns one even byte and one odd byte.
3. Column addresses 8936 (22E8h) through 16,383 (3FFFh) are invalid, out of bounds, do not exist in the device, and cannot be addressed.
4. BA[8] is the plane-select bit:
Plane 0: BA[8] = 0
Plane 1: BA[8] = 1
5. LA0 is the LUN-select bit. It is present only when two LUNs are shared on the target; otherwise, it should be held LOW.
LUN 0: LA0 = 0
LUN 1: LA0 = 1



8 Bus Operation – Asynchronous Interface

The asynchronous interface is active when the NAND Flash device powers on. The I/O bus, DQ[7:0], is multiplexed sharing data I/O, addresses, and commands. The DQS signal, if present, is tri-stated when the asynchronous interface is active. Asynchronous interface bus modes are summarized below.

Table 3: Asynchronous Interface Mode Selection

Mode	CE#	CLE	ALE	WE#	RE#	DQS	DQx	WP#	Notes
Standby	H	X	X	X	X	X	X	0V/V _{CCQ} ²	2
Bus idle	L	X	X	H	H	X	X	X	
Command input	L	H	L		H	X	input	H	
Address input	L	L	H		H	X	input	H	
Data input	L	L	L		H	X	input	H	
Data output	L	L	L	H		X	output	X	
Write protect	X	X	X	X	X	X	X	L	

Notes:

1. DQS is tri-stated when the asynchronous interface is active.
2. WP# should be biased to CMOS LOW or HIGH for standby.
3. Mode selection settings for this table: H = Logic level HIGH; L = Logic level LOW; X = V_{IH} or V_{IL}.

8.1 Asynchronous Enable/Standby

A chip enable (CE#) signal is used to enable or disable a target. When CE# is driven LOW, all of the signals for that target are enabled. With CE# LOW, the target can accept commands, addresses, and data I/O. There may be more than one target in a NAND Flash package. Each target is controlled by its own chip enable; the first target (Target 0) is controlled by CE#; the second target (if present) is controlled by CE2#, etc.

A target is disabled when CE# is driven HIGH, even when the target is busy. When disabled, all of the target's signals are disabled except CE#, WP#, and R/B#. This functionality is also known as CE# "Don't Care". While the target is disabled, other devices can utilize the disabled NAND signals that are shared with the NAND Flash.

A target enters low-power standby when it is disabled and is not busy. If the target is busy when it is disabled, the target enters standby after all of the die (LUNs) complete their operations. Standby helps reduce power consumption.

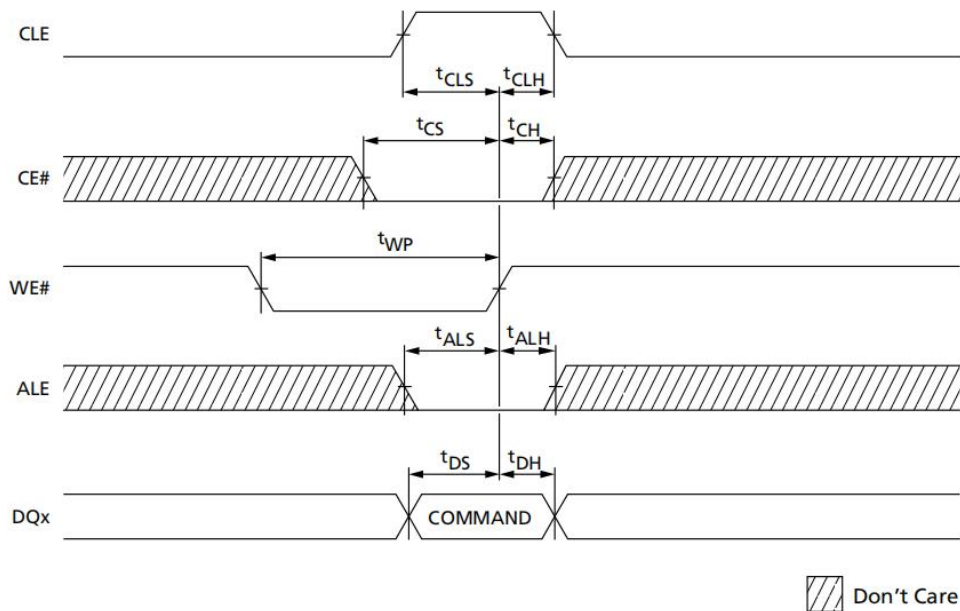
8.2 Asynchronous Bus Idle

A target's bus is idle when CE# is LOW, WE# is HIGH, and RE# is HIGH. During bus idle, all of the signals are enabled except DQS, which is not used when the asynchronous interface is active. No commands, addresses, and data are latched into the target; no data is output.

8.3 Asynchronous Commands

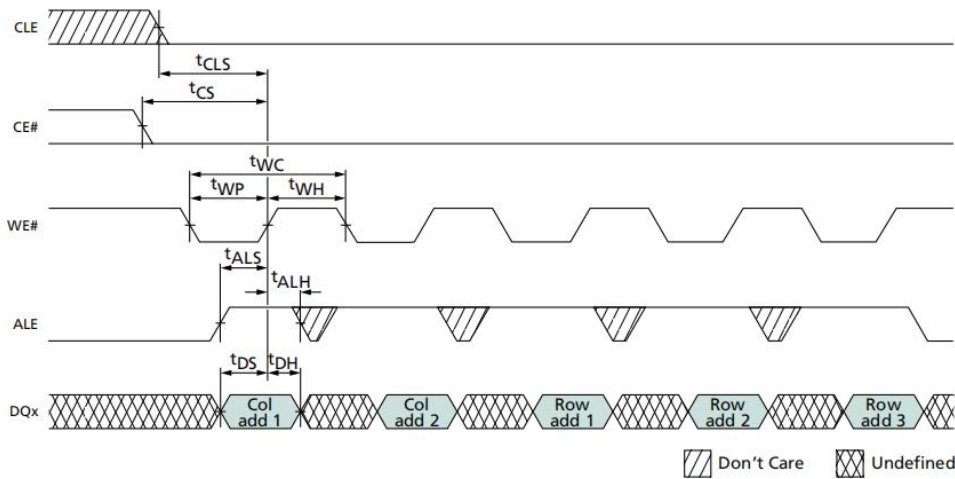
An asynchronous command is written from DQ[7:0] to the command register on the rising edge of WE# when CE# is LOW, ALE is LOW, CLE is HIGH, and RE# is HIGH. Commands are typically ignored by die (LUNs) that are busy (RDY = 0); however, some commands, including READ STATUS (70h) and READ STATUS ENHANCED (78h), are accepted by die (LUNs) even when they are busy.

Figure 7: Asynchronous Command Latch Cycle



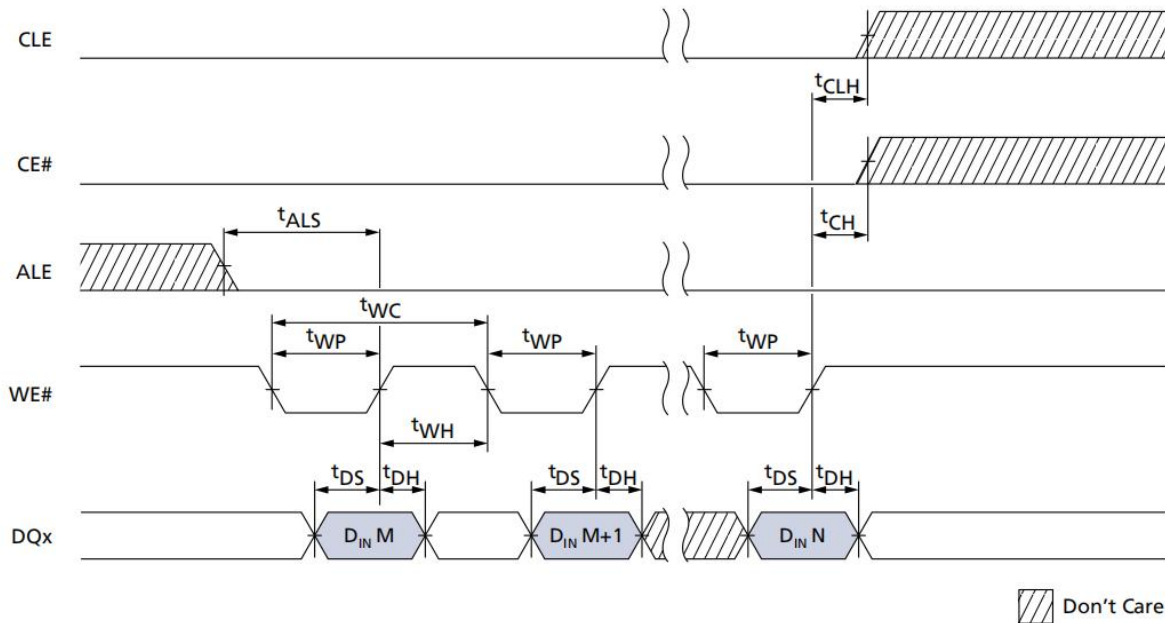
8.4 Asynchronous Addresses

An asynchronous address is written from DQ[7:0] to the address register on the rising edge of WE# when CE# is LOW, ALE is HIGH, CLE is LOW, and RE# is HIGH. Bits that are not part of the address space must be LOW (see Device and Array Organization). The number of cycles required for each command varies. Refer to the command descriptions to determine addressing requirements (see Command Definitions). Addresses are typically ignored by die (LUNs) that are busy (RDY = 0); however, some addresses are accepted by die (LUNs) even when they are busy; for example, address cycles that follow the READ STATUS ENHANCED (78h) command.

Figure 8: Asynchronous Address Latch Cycle


8.5 Asynchronous Data Input

Data is written from DQ[7:0] to the cache register of the selected die (LUN) on the rising edge of WE# when CE# is LOW, ALE is LOW, CLE is LOW, and RE# is HIGH. Data input is ignored by die (LUNs) that are not selected or are busy (RDY = 0).

Figure 9: Asynchronous Data Input Cycles


8.6 Asynchronous Data Output

Data can be output from a die (LUN) if it is in a READY state. Data output is supported following a READ operation from the NAND Flash array. Data is output from the cache register of the selected die (LUN) to DQ[7:0] on the falling edge of RE# when CE# is LOW, ALE is LOW, CLE is LOW, and WE# is HIGH.

If the host controller is using a t_{RC} of 30ns or greater, the host can latch the data on the rising edge of RE# (see Figure 20 for proper timing). If the host controller is using a t_{RC} of less than 30ns, the host can latch the data on the next falling edge of RE# (see Figure 21 (page 30) for extended data output (EDO) timing).

Using the READ STATUS ENHANCED (78h) command prevents data contention following an interleaved die (multi-LUN) operation. After issuing the READ STATUS ENHANCED (78h) command, to enable data output, issue the READ MODE (00h) command. Data output requests are typically ignored by a die (LUN) that is busy ($RDY = 0$); however, it is possible to output data from the status register even when a die (LUN) is busy by first issuing the READ STATUS (70h) or READ STATUS ENHANCED (78h) command.

Figure 10: Asynchronous Data Output Cycles

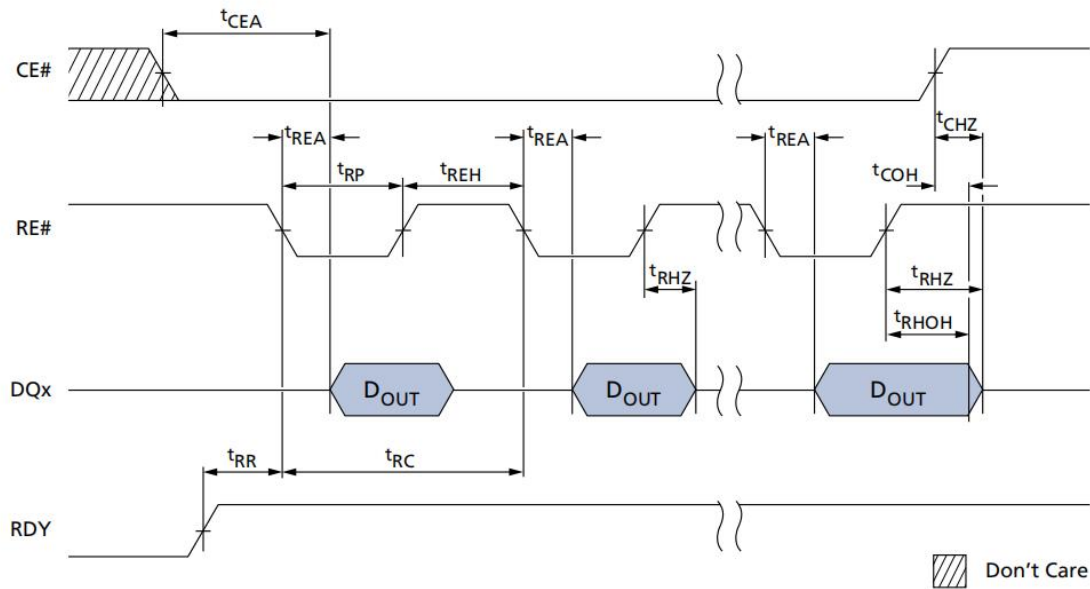
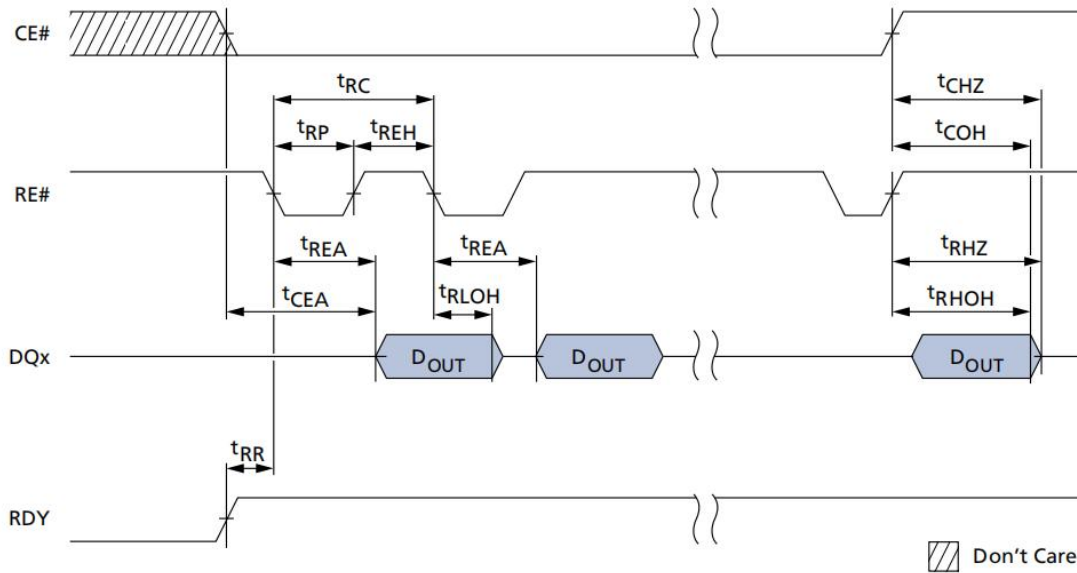


Figure 11: Asynchronous Data Output Cycles (EDO Mode)


9 Write Protect

The write protect# (WP#) signal enables or disables PROGRAM and ERASE operations to a target. When WP# is LOW, PROGRAM and ERASE operations are disabled. When WP# is HIGH, PROGRAM and ERASE operations are enabled.

It is recommended that the host drive WP# LOW during power-on until Vcc and Vccq are stable to prevent inadvertent PROGRAM and ERASE operations (see Device Initialization (page 43) for additional details). WP# must be transitioned only when the target is not busy and prior to beginning a command sequence. After a command sequence is complete and the target is ready, WP# can be transitioned. After WP# is transitioned, the host must wait tWW before issuing a new command.

The WP# signal is always an active input, even when CE# is HIGH. This signal should not be multiplexed with other signals.

10 Ready/Busy#

The ready/busy# (R/B#) signal provides a hardware method of indicating whether a target is ready or busy. A target is busy when one or more of its die (LUNs) are busy (RDY = 0). A target is ready when all of its die (LUNs) are ready (RDY = 1). Because each die (LUN) contains a status register, it is possible to determine the independent status of each die (LUN) by polling its status register instead of using the R/B# signal (see Status Operations for details regarding die (LUN) status).

This signal requires a pull-up resistor, Rp, for proper operation. R/B# is HIGH when the target is ready, and transitions LOW when the target is busy. The signal's open-drain driver enables multiple R/B# outputs to be OR-tied. Typically, R/B# is connected to an interrupt pin on the system controller (see Figure 22 (page 31)).

The combination of R_p and capacitive loading of the R/B# circuit determines the rise time of the R/B# signal. The actual value used for R_p depends on the system timing requirements. Large values of R_p cause R/B# to be delayed significantly. Between the 10- to 90-percent points on the R/B# waveform, the rise time is approximately two time constants (TC).

$$TC = R \times C$$

Where $R = R_p$ (resistance of pull-up resistor), and $C =$ total capacitive load.

The fall time of the R/B# signal is determined mainly by the output impedance of the R/B# signal and the total load capacitance. Approximate R_p values using a circuit load of 100pF are provided in Figure 27 (page 34).

The minimum value for R_p is determined by the output drive capability of the R/B# signal, the output voltage swing, and V_{ccq} .

$$R_p = \frac{V_{cc}(\text{MAX}) - V_{ol}(\text{MAX})}{I_{OL} + \sum i_l}$$

Where $\sum i_l$ is the sum of the input currents of all devices tied to the R/B# pin.

Figure 12: READ/BUSY# Open Drain

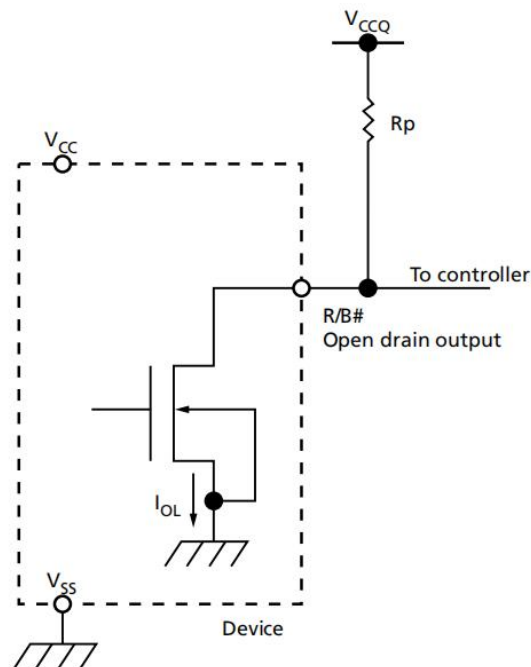
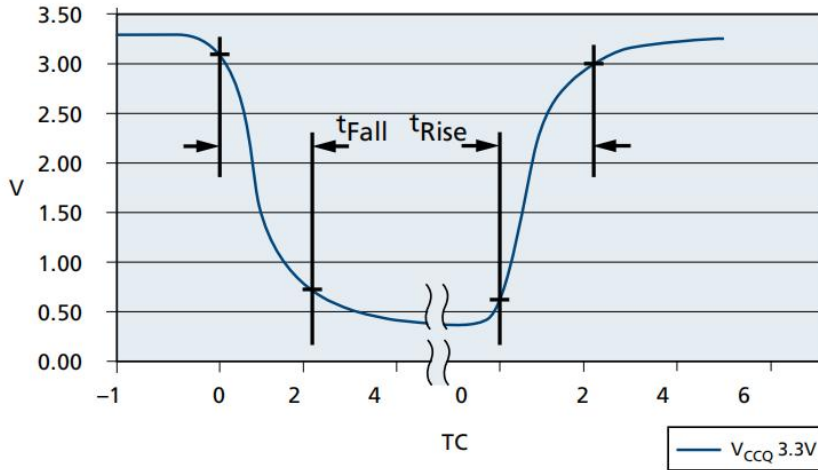
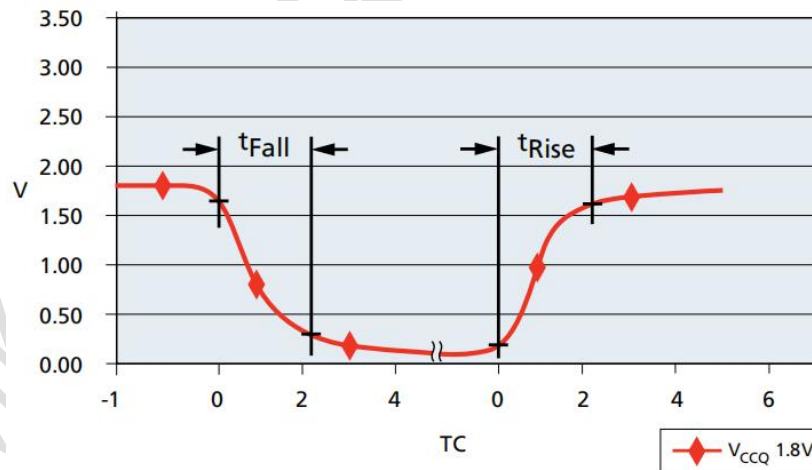


Figure 13: t_{Fall} and t_{Rise} ($V_{CCQ} = 2.7-3.6V$)


Notes:

1. t_{FALL} is $V_{OH(DC)}$ to $V_{OL(AC)}$ and t_{RISE} is $V_{OL(DC)}$ to $V_{OH(AC)}$.
2. t_{Rise} dependent on external capacitance and resistive loading and output transistor impedance.
3. t_{Rise} primarily dependent on external pull-up resistor and external capacitive loading.
4. $t_{Fall} = 10ns$ at 3.3V
5. See TC values in Figure 27 (page 34) for approximate R_p value and TC.

Figure 14: t_{Fall} and t_{Rise} ($V_{CCQ} = 1.7-1.95V$)


Notes:

1. t_{FALL} is $V_{OH(DC)}$ to $V_{OL(AC)}$ and t_{RISE} is $V_{OL(DC)}$ to $V_{OH(AC)}$.
2. t_{Rise} is primarily dependent on external pull-up resistor and external capacitive loading.
3. $t_{Fall} \approx 7ns$ at 1.8V.
4. See TC values in Figure 27 (page 34) for TC and approximate R_p value.



Figure 15: IOL vs Rp (Vccq = 2.7-3.6V)

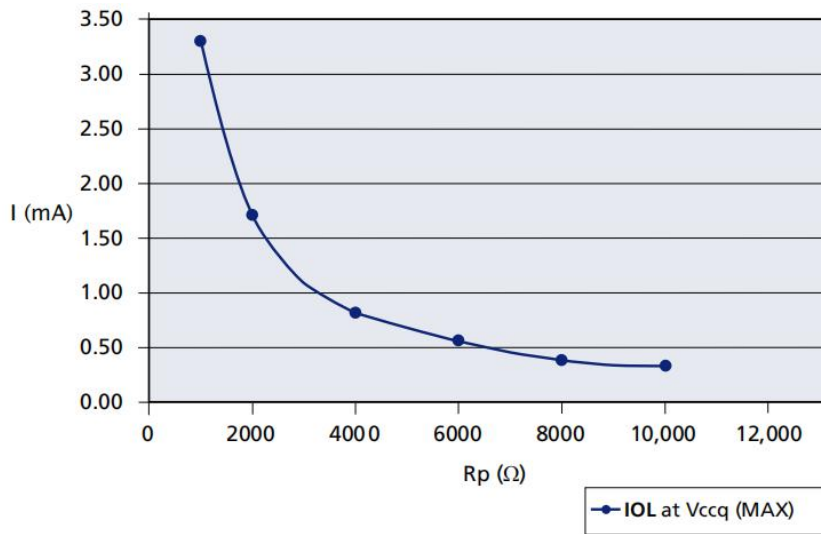


Figure 16: IOL vs Rp (Vccq = 1.7-1.95V)

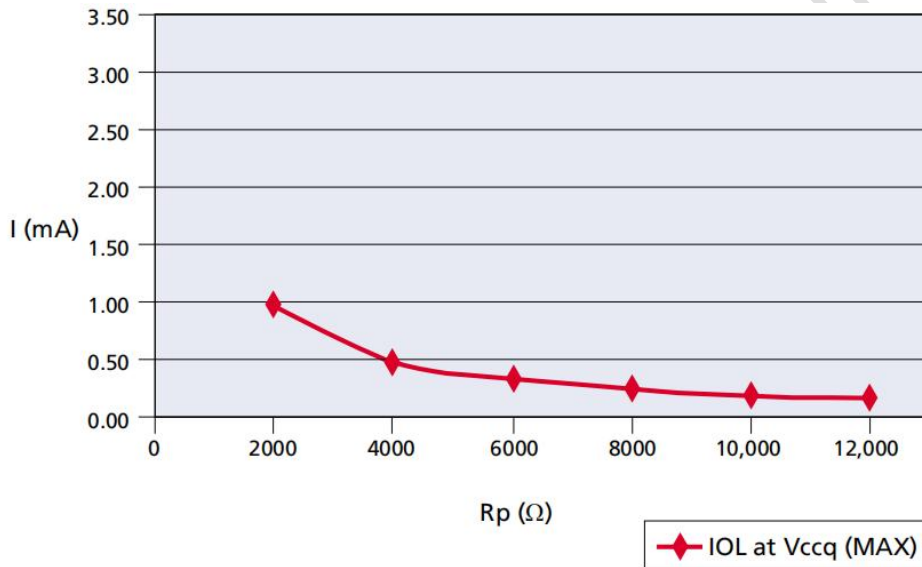
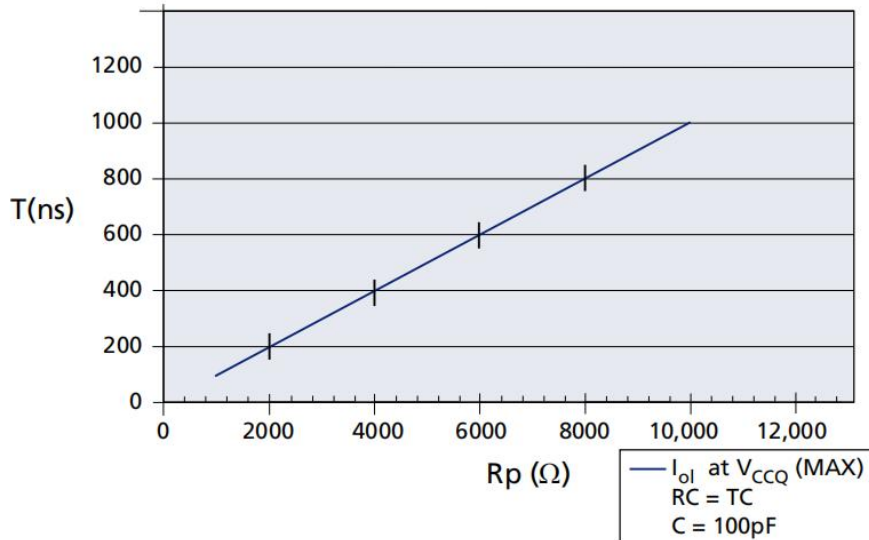




Figure 17: TC vs Rp



11 Bus Operation – Synchronous Interface

These NAND Flash devices have two interfaces—a synchronous interface for fast data I/O transfer and an asynchronous interface that is backward compatible with existing NAND Flash devices.

The NAND Flash command protocol for both the asynchronous and synchronous interfaces is identical. However, there are some differences between the asynchronous and synchronous interfaces when issuing command, address, and data I/O cycles using the NAND Flash signals.

When the synchronous interface is activated on a target (see Activating Interfaces), the target is capable of high-speed DDR data transfers. Existing signals are redefined for high speed DDR I/O. The WE# signal becomes CLK. DQS is enabled. The RE# signal becomes W/R#. CLK provides a clock reference to the NAND Flash device. DQS is a bidirectional data strobe. During data output, DQS is driven by the NAND Flash device. During data input, DQS is controlled by the host controller while inputting data on DQ[7:0]. The direction of DQS and DQ[7:0] is controlled by the W/R# signal. When the W/R# signal is latched HIGH, the controller is driving the DQ bus and DQS. When the W/R# is latched LOW, the NAND Flash is driving the DQ bus and DQS. The synchronous interface bus modes are summarized below.

**Table 4: Synchronous Interface Mode Selection**

Mode	CE#	CLE	ALE	CLK	W/R#	DQS	DQ[7:0]	WP#	Notes
Standby	H	X	X	X	X	X	X	0V/V _{CCQ}	1, 2
Bus idle	L	L	L		H	X	X	X	
Bus driving	L	L	L		L	output	output	X	
Command input	L	H	L		H	X	input	H	3
Address input	L	L	H		H	X	input	H	3
Data input	L	H	H		H		input	H	4
Data output	L	H	H		L	See Note	output	X	5
Write protect	X	X	X	X	X	X	X	L	
Undefined	L	L	H		L	output	output	X	
Undefined	L	H	L		L	output	output	X	

Notes:

1. CLK can be stopped when the target is disabled, even when R/B# is LOW.
2. WP# should be biased to CMOS LOW or HIGH for standby.
3. Commands and addresses are latched on the rising edge of CLK.
4. During data input to the device, DQS is the "clock" that latches the data in the cache register.
5. During data output from the NAND Flash device, DQS is an output generated from CLK after t_{DQSCK} delay.
6. Mode selection settings for this table: H = Logic level HIGH; L = Logic level LOW; X = V_{IH} or V_{IL}.

11.1 Synchronous Enable/Standby

In addition to the description found in Asynchronous Enable/Standby (page 25), the following requirements also apply when the synchronous interface is active.

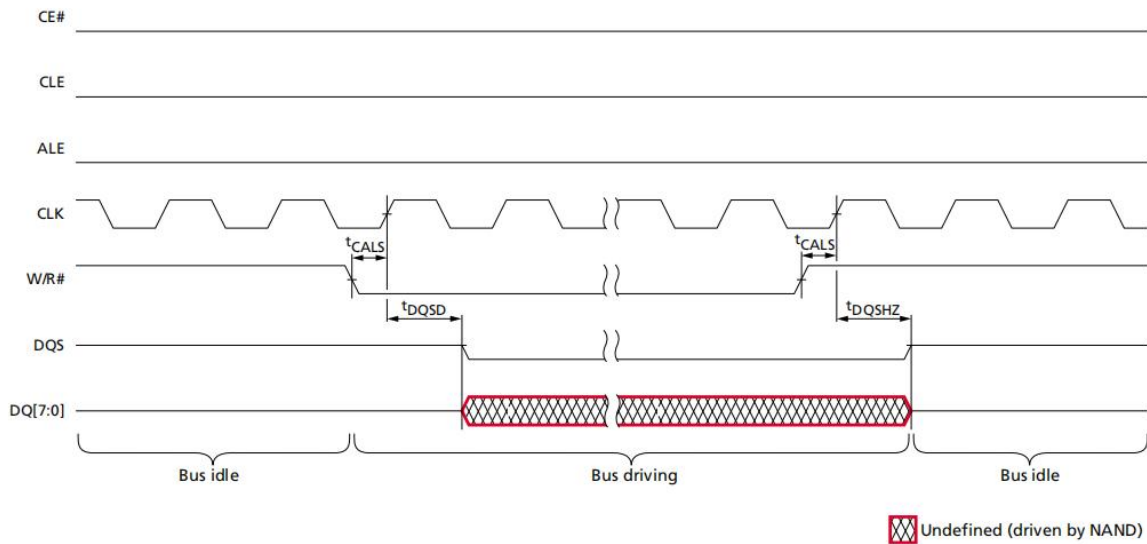
Before enabling a target, CLK must be running and ALE and CLE must be LOW. When CE# is driven LOW, all of the signals for the selected target are enabled. The target is not enabled until tCS completes; the target's bus is then idle. Prior to disabling a target, the target's bus must be idle. A target is disabled when CE# is driven HIGH, even when it is busy. All of the target's signals are disabled except CE#, WP#, and R/B#. After the target is disabled, CLK can be stopped. A target enters low-power standby when it is disabled and is not busy. If the target is busy when it is disabled, the target enters standby after all of the die (LUNs) complete their operations.

11.2 Synchronous Bus Idle/Driving

A target's bus is idle or driving when CLK is running, CE# is LOW, ALE is LOW, and CLE is LOW.

The bus is idle when W/R# transitions HIGH and is latched by CLK. During the bus idle mode, all signals are enabled; DQS and DQ[7:0] are inputs. No commands, addresses, or data are latched into the target; no data is output. When entering the bus idle mode, the host must wait a minimum of tCAD before changing the bus mode. In the bus idle mode, the only valid bus modes supported are: bus driving, command, address, and DDR data input.

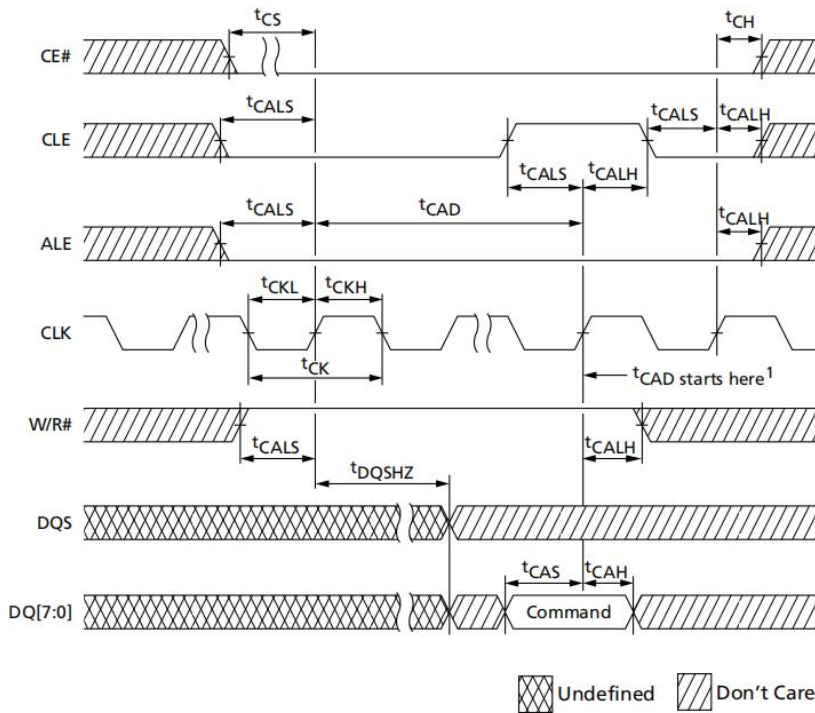
The bus is driving when W/R# transitions LOW and is latched by CLK. During the bus driving mode, all signals are enabled; DQS is LOW and DQ[7:0] is driven LOW or HIGH, but no valid data is output. Following the bus driving mode, the only valid bus modes supported are bus idle and DDR data output.

Figure 18: Synchronous Bus Idle/Driving Behavior

Note:

1. Only the selected die (LUN) drives DQS and DQ[7:0]. During an interleaved die (multi LUN) operation, the host must use the READ STATUS ENHANCED (78h) to prevent data output contention.

11.3 Synchronous Commands

A command is written from DQ[7:0] to the command register on the rising edge of CLK when CE# is LOW, ALE is LOW, CLE is HIGH, and W/R# is HIGH. After a command is latched—and prior to issuing the next command, address, or data I/O—the bus must go to bus idle mode on the next rising edge of CLK, except when the clock period, t_{CK} , is greater than t_{CAD} . Commands are typically ignored by die (LUNs) that are busy ($RDY = 0$); however, some commands, such as READ STATUS (70h) and READ STATUS ENHANCED (78h), are accepted by die (LUNs), even when they are busy.

Figure 19: Synchronous Command Cycle


Note:

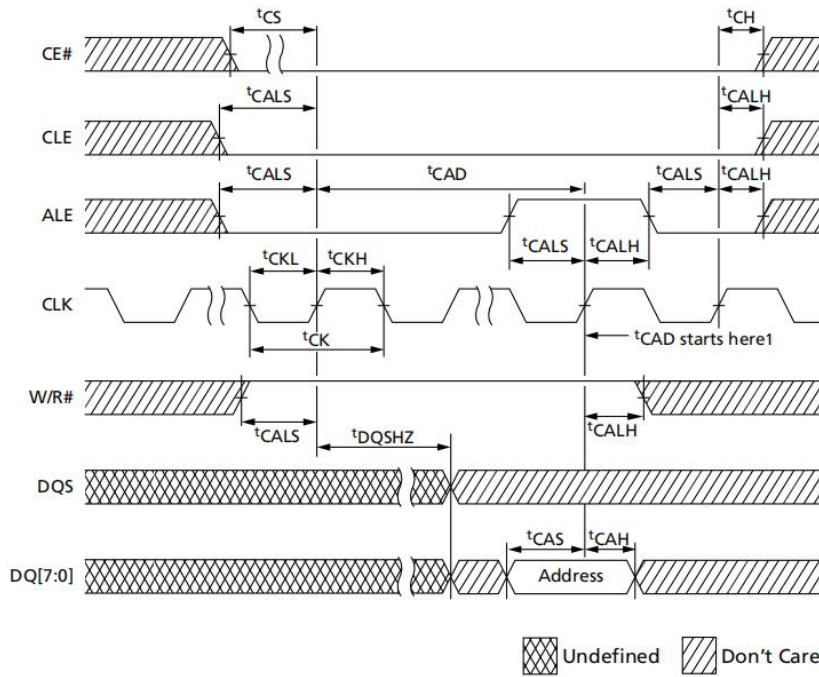
1. When CE# remains LOW, t_{CAD} begins at the rising edge of the clock from which the command cycle is latched for subsequent command, address, data input, or data output cycle(s).

11.4 Synchronous Addresses

A synchronous address is written from DQ[7:0] to the address register on the rising edge of CLK when CE# is LOW, ALE is HIGH, CLE is LOW, and W/R# is HIGH. After an address is latched—and prior to issuing the next command, address, or data I/O—the bus must go to bus idle mode on the next rising edge of CLK, except when the clock period, t_{CK} , is greater than t_{CAD} . Bits not part of the address space must be LOW (see Device and Array Organization).

The number of address cycles required for each command varies. Refer to the command descriptions to determine addressing requirements.

Addresses are typically ignored by die (LUNs) that are busy ($RDY = 0$); however, some addresses such as address cycles that follow the READ STATUS ENHANCED (78h) command, are accepted by die (LUNs), even when they are busy.

Figure 20: Synchronous Address Cycle

Note:

1. When CE# remains LOW, t_{CAD} begins at the rising edge of the clock from which the command cycle is latched for subsequent command, address, data input, or data output cycle(s).

11.5 Synchronous DDR Data Input

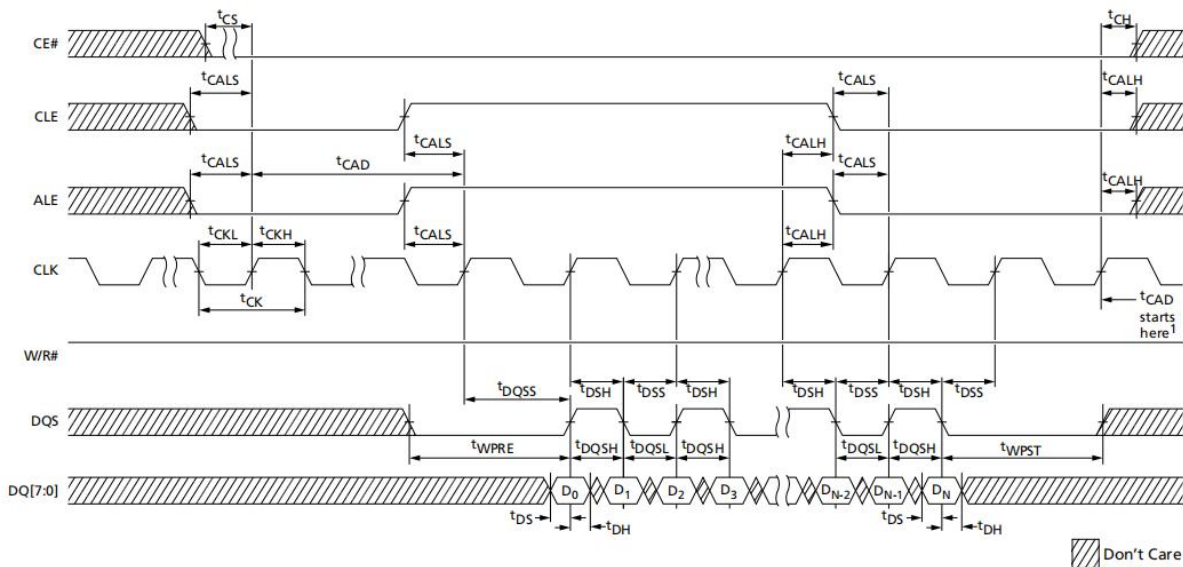
To enter the DDR data input mode, the following conditions must be met:

- CLK is running
- CE# is LOW
- W/R# is HIGH
- tCAD is met
- DQS is LOW
- ALE and CLE are HIGH on the rising edge of CLK

Upon entering the DDR data input mode after tDQSS, data is written from DQ[7:0] to the cache register on each and every rising and falling edge of DQS (center-aligned) when CLK is running and the DQS to CLK skew meets tDSH and tDSS, CE# is LOW, W/R# is HIGH, and ALE and CLE are HIGH on the rising edge of CLK. To exit DDR data input mode, the following conditions must be met:

- CLK is running and the DQS to CLK skew meets tDSH and tDSS
- CE# is LOW
- W/R# is HIGH
- ALE and CLE are latched LOW on the rising edge of CLK
- The final two data bytes of the data input sequence are written to DQ[7:0] to the cache register on the rising and falling edges of DQS after the last cycle in the data input sequence in which ALE and CLE are latched HIGH.
- DQS is held LOW for tWPST (after the final falling edge of DQS)

Following tWPST, the bus enters bus idle mode and tCAD begins on the next rising edge of CLK. After tCAD starts, the host can disable the target if desired. Data input is ignored by die (LUNs) that are not selected or are busy.

Figure 21: Synchronous DDR Data Input Cycles

Notes:

1. When CE# remains LOW, tCAD begins at the first rising edge of the clock after tWPST completes.
2. tDSH (MIN) generally occurs during tDQSS (MIN).
3. tDSS (MIN) generally occurs during tDQSS (MAX).

11.6 Synchronous DDR Data Output

Data can be output from a die (LUN) if it is ready. Data output is supported following a READ operation from the NAND Flash array.

To enter the DDR data output mode, the following conditions must be met:

- CLK is running
- CE# is LOW
- The host has released the DQ[7:0] bus and DQS
- W/R# is latched LOW on the rising edge of CLK to enable the selected die (LUN) to take ownership of the DQ[7:0] bus and DQS within tWRCK
- tCAD is met
- ALE and CLE are HIGH on the rising edge of CLK

Upon entering the DDR data output mode, DQS will toggle HIGH and LOW with a delay of tDQSC from the respective rising and falling edges of CLK. DQ[7:0] will output data edge-aligned to the rising and falling edges of DQS, with the first transition delayed by no more than tAC.

DDR data output mode continues as long as CLK is running, CE# is LOW, W/R# is LOW, and ALE and CLE are HIGH on the rising edge of CLK.

To exit DDR data output mode, the following conditions must be met:

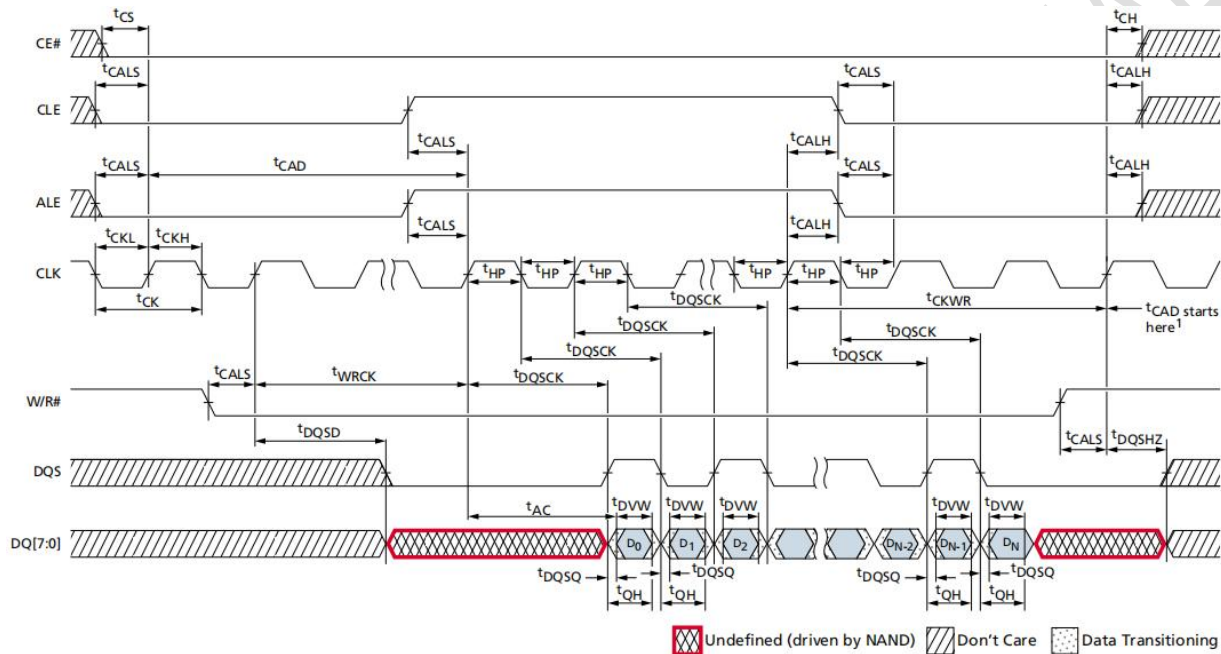
- CLK is running
- CE# is LOW
- W/R# is LOW

- ALE and CLE are latched LOW on the rising edge of CLK

The final two data bytes are output on DQ[7:0] on the final rising and falling edges of DQS. The final rising and falling edges of DQS occur t_{DQSCK} after the last cycle in the data output sequence in which ALE and CLE are latched HIGH. After t_{CKWR} , the bus enters bus idle mode and t_{CAD} begins on the next rising edge of CLK. Once t_{CAD} starts the host can disable the target if desired.

Data output requests are typically ignored by a die (LUN) that is busy ($RDY = 0$); however, it is possible to output data from the status register even when a die (LUN) is busy by issuing the READ STATUS (70h) or READ STATUS ENHANCED (78h) command.

Figure 22: Synchronous DDR Data Output Cycles



Notes:

1. When CE# remains LOW, t_{CAD} begins at the rising edge of the clock after t_{CKWR} for subsequent command or data output cycle(s).
2. See Figure 29 (page 38) for details of W/R# behavior.
3. t_{AC} is the DQ output window relative to CLK and is the long-term component of DQ skew.
4. For W/R# transitioning HIGH, DQ[7:0] and DQS go to tri-state.
5. For W/R# transitioning LOW, DQ[7:0] drives current state and DQS goes LOW.
6. After final data output, DQ[7:0] is driven until W/R# goes HIGH, but is not valid.

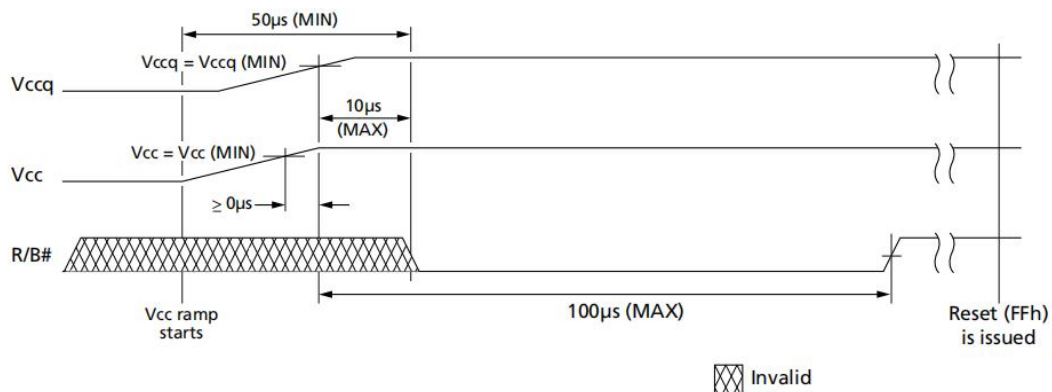
12 Device Initialization

Some NAND Flash devices do not support VCCQ. For these devices all references to VCCQ are replaced with VCC.

Micron NAND Flash devices are designed to prevent data corruption during power transitions. VCC is internally monitored. (The WP# signal supports additional hardware protection during power transitions.) When ramping VCC and VCCQ, use the following procedure to initialize the device:

1. Ramp VCC.
 2. Ramp VCCQ. VCCQ must not exceed VCC.
 3. The host must wait for R/B# to be valid and HIGH before issuing RESET (FFh) to any target (see Figure 33). The R/B# signal becomes valid when 50 μ s has elapsed since the beginning the VCC ramp, and 10 μ s has elapsed since VCCQ reaches VCCQ (MIN) and VCC reaches VCC (MIN).
 4. If not monitoring R/B#, the host must wait at least 100 μ s after VCCQ reaches VCCQ (MIN) and VCC reaches VCC (MIN). If monitoring R/B#, the host must wait until R/B# is HIGH.
 5. The asynchronous interface is active by default for each target. Each LUN draws less than an average of 10mA (IST) measured over intervals of 1ms until the RESET (FFh) command is issued.
 6. The RESET (FFh) command must be the first command issued to all targets (CE#s) after the NAND Flash device is powered on. Each target will be busy for tPOR after a RESET command is issued. The RESET busy time can be monitored by polling R/B# or issuing the READ STATUS (70h) command to poll the status register.
 7. The device is now initialized and ready for normal operation.
- At power-down, VCCQ must go LOW, either before, or simultaneously with, VCC going LOW.

Figure 23: R/B# Power-On Behavior



Note:

1. Disregard Vccq for devices that use only Vcc.



13 Activating Interfaces

After performing the steps under Device Initialization (page 43), the asynchronous interface is active for all targets on the device.

Each target's interface is independent of other targets, so the host is responsible for changing the interface for each target.

If the host and NAND Flash device, through error, are no longer using the same interface, then steps under Activating the Asynchronous Interface are performed to resynchronize the interfaces.

13.1 Activating the Asynchronous Interface

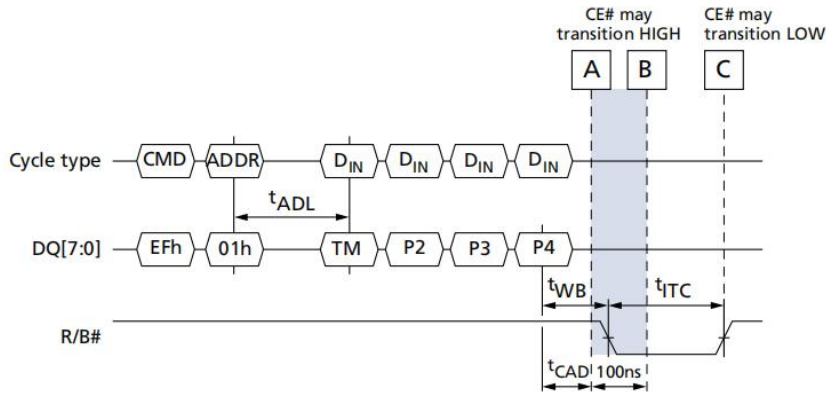
To activate the asynchronous NAND interface, once the synchronous interface is active, the following steps are repeated for each target:

1. The host pulls CE# HIGH, disables its input to CLK, and enables its asynchronous interface.
2. The host pulls CE# LOW and issues the RESET (FFh) command, using an asynchronous command cycle.
3. R/B# goes LOW for tRST.
4. After tITC, and during tRST, the device enters the asynchronous NAND interface. READ STATUS (70h) and READ STATUS ENHANCED (78h) are the only commands that can be issued.
5. After tRST, R/B# goes HIGH. Timing mode feature address (01h), subfeature parameter P1 is set to 00h, indicating that the asynchronous NAND interface is active and that the device is set to timing mode 0. For further details, see Reset Operations.

13.2 Activating the Synchronous Interface

To activate the synchronous NAND Flash interface, the following steps are repeated for each target:

1. Issue the SET FEATURES (EFh) command.
2. Write address 01h, which selects the timing mode.
3. Write P1 with 1Xh, where "X" is the timing mode used in the synchronous interface (see Configuration Operations).
4. Write P2–P4 as 00h-00h-00h.
5. R/B# goes LOW for tITC. The host should pull CE# HIGH. During tITC, the host should not issue any type of command, including status commands, to the NAND Flash device.
6. After tITC, R/B# goes HIGH and the synchronous interface is enabled. Before pulling CE# LOW, the host should enable the clock.

Figure 24: Activating the Synchronous Interface


Note: 1. TM = Timing mode.

14 Command Definitions

Table 5: Command Set

Command	Command Cycle #1	Number of Valid Address Cycles	Data Input Cycles	Command Cycle #2	Number of Valid Address Cycles #2	Command Cycle #3	Valid While Selected LUN is Busy ¹	Valid While Other LUNs are Busy ²	Notes
Reset Operations									
RESET	FFh	0	-	-	-	-	Yes	Yes	
SYNCHRONOUS RESET	FCh	0	-	-	-	-	Yes	Yes	
RESET LUN	FAh	3	-	-	-	-	Yes	Yes	
Identification Operations									
READ ID	90h	1	-	-	-	-			3
READ PARAMETER PAGE	ECh	1	-	-	-	-			
READ UNIQUE ID	EDh	1	-	-	-	-			
Configuration Operations									
GET FEATURES	EEh	1	-	-	-	-			3
SET FEATURES	EFh	1	4	-	-	-			4
Status Operations									
READ STATUS	70h	0	-	-	-	-	Yes		
READ STATUS ENHANCED	78h	3	-	-	-	-	Yes	Yes	
Column Address Operations									



CHANGE READ COLUMN	05h	2	-	E0h	-	-		Yes	
CHANGE READ COLUMN ENHANCED (ONFI)	06h	5	-	E0h	-	-		Yes	
CHANGE READ COLUMN ENHANCED (JEDEC)	00h	5	-	05h	2	E0h		Yes	
CHANGE WRITE COLUMN	85h	2	Optional	-	-	-		Yes	
CHANGE ROW ADDRESS	85h	5	Optional	11h (Optional)	-	-		Yes	5
Read Operations									
READ MODE	00h	0	-	-	-	-		Yes	
READ PAGE	00h	5	-	30h	-	-		Yes	6
READ PAGE MULTIPLE	00h	5	-	32h	-	-		Yes	
READ PAGE CACHE SEQUENTIAL	31h	0	-	-	-	-		Yes	7



Command	Command Cycle #1	Number of Valid Address Cycles	Data Input Cycles	Command Cycle #2	Number of Valid Address Cycles #2	Command Cycle #3	Valid While Selected LUN is Busy ¹	Valid While Other LUNs are Busy ²	Notes
READ PAGE CACHE RANDOM	00h	5	–	31h	–	–		Yes	6,7
READ PAGE CACHE LAST	3Fh	0	–	–	–	–		Yes	7
Program Operations									
PROGRAM PAGE	80h or 81h	5	Yes	10h	–	–		Yes	
PROGRAM PAGE MULTI-PLANE	80h or 81h	5	Yes	11h	–	–		Yes	
PROGRAM PAGE CACHE	80h or 81h	5	Yes	15h	–	–		Yes	8
Erase Operations									
ERASE BLOCK	60h	3	–	D0h	–	–		Yes	
ERASE BLOCK MULTI-PLANE (ONFI)	60h	3	–	D1h	–	–		Yes	
ERASE BLOCK MULTI-PLANE (JEDEC)	60h	3	–	60h	3	D0h		Yes	
Copyback Operations									
COPYBACK READ	00h	5	–	35h	–	–		Yes	6
COPYBACK PROGRAM	85h	5	Optional	10h	–	–		Yes	
COPYBACK PROGRAM MULTI-PLANE	85h	5	Optional	11h	–	–		Yes	

Notes:

1. Busy means RDY = 0.
2. These commands can be used for interleaved die (multi-LUN) operations.
3. The READ ID (90h) and GET FEATURES (EEh) output identical data on rising and falling DQS edges.
4. The SET FEATURES (EFh) command requires data transition prior to the rising edge of CLK, with identical data for the rising and falling edges.
5. Command cycle #2 of 11h is conditional. See CHANGE ROW ADDRESS (85h) (page 78) for more details.
6. This command can be preceded by READ PAGE MULTI-PLANE (00h-32h) command to accommodate a maximum simultaneous multi-plane array operation.
7. Issuing a READ PAGE CACHE-series (31h, 00h-31h, 00h-32h, 3Fh) command when the array is busy (RDY = 1, ARDY = 0) is supported if the previous command was a READ PAGE (00h-30h) or READ PAGE CACHE-series command; otherwise, it is prohibited.
8. Issuing a PROGRAM PAGE CACHE (80h-15h) command when the array is busy (RDY = 1, ARDY = 0) is supported if the previous command was a PROGRAM PAGE CACHE (80h-15h) command; otherwise, it is prohibited.

15 Reset Operations

15.1 RESET (FFh)

The RESET (FFh) command is used to put a target into a known condition and to abort command sequences in progress. This command is accepted by all die (LUNs), even when they are busy.

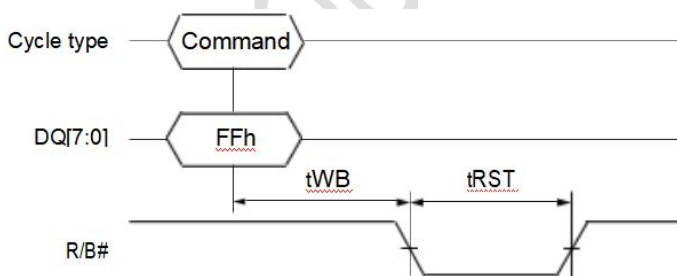
When FFh is written to the command register, the target goes busy for t_{RST} . During t_{RST} , the selected target (CE#) discontinues all array operations on all die (LUNs). All pending single- and multi-plane operations are cancelled. If this command is issued while a PROGRAM or ERASE operation is occurring on one or more die (LUNs), the data may be partially programmed or erased and is invalid. The command register is cleared and ready for the next command. The data register and cache register contents are invalid.

RESET must be issued as the first command to each target following power-up (see Device Initialization (page 43)). Use of the READ STATUS ENHANCED (78h) command is prohibited during the power-on RESET. To determine when the target is ready, use READ STATUS (70h).

If the RESET (FFh) command is issued when the synchronous interface is enabled, the target's interface is changed to the asynchronous interface and the timing mode is set to 0. The RESET (FFh) command can be issued asynchronously when the synchronous interface is active, meaning that CLK does not need to be continuously running when CE# is transitioned LOW and FFh is latched on the rising edge of CLK. After this command is latched, the host should not issue any commands during t_{ITC} . After t_{ITC} , and during or after t_{RST} , the host can poll each LUN's status register.

If the RESET (FFh) command is issued when the asynchronous interface is active, the target's asynchronous timing mode remains unchanged. During or after t_{RST} , the host can poll each LUN's status register.

Figure 25: RESET (FFh) Operation



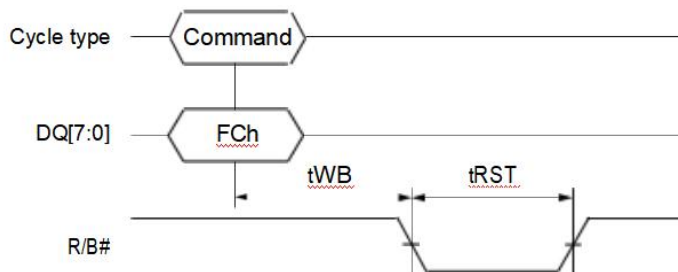
15.2 SYNCHRONOUS RESET (FCh)

When the synchronous interface is active, the SYNCHRONOUS RESET (FCh) command is used to put a target into a known condition and to abort command sequences in progress. This command is accepted by all die (LUNs), even when they are BUSY.

When FCh is written to the command register, the target goes busy for t_{RST} . During t_{RST} , the selected target (CE#) discontinues all array operations on all die (LUNs). All pending single and multi-plane operations are cancelled. If this command is issued while a PROGRAM or ERASE operation is occurring on one or more die (LUNs), the data may be partially programmed or erased and is invalid. The command register is cleared and ready for the next command. The data register and cache register contents are invalid and the synchronous interface remains active.

During or after t_{RST} , the host can poll each LUN's status register. SYNCHRONOUS RESET is only accepted while the synchronous interface is active. Its use is prohibited when the asynchronous interface is active.

Figure 26: SYNCHRONOUS RESET (FCh) Operation



15.3 RESET LUN (FAh)

The RESET LUN (FAh) command is used to put a particular LUN on a target into a known condition and to abort command sequences in progress. This command is accepted by only the LUN addressed by the RESET LUN (FAh) command, even when that LUN is busy.

When FAh is written to the command register, the addressed LUN goes busy for t_{RST} . During t_{RST} , the selected LUN discontinues all array operations. All pending single and multi-plane operations are canceled. If this command is issued while a PROGRAM or ERASE operation is occurring on the addressed LUN, the data may be partially programmed or erased and is invalid. The command register is cleared and ready for the next command. The data register and cache register contents are invalid.

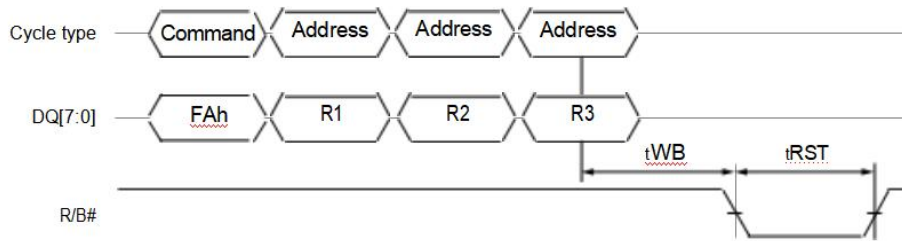
If the RESET LUN (FAh) command is issued when the synchronous interface is enabled, the target's interface remains in synchronous mode.

If the RESET LUN (FAh) command is issued when the asynchronous interface is enabled, the target's interface remains in asynchronous mode.

During or after t_{RST} , the host can poll each LUN's status register.

The RESET LUN (FAh) command is prohibited when not in the default array operation mode.

The RESET LUN (FAh) command can only be issued to a target (CE#) after the RESET (FFh) command has been issued as the first command to a target following power-up.

Figure 27: RESET LUN (FAh) Operation


16 Identification Operations

16.1 READ ID (90h)

The READ ID (90h) command is used to read identifier codes programmed into the target. This command is accepted by the target only when all die (LUNs) on the target are idle.

Writing 90h to the command register puts the target in read ID mode. The target stays in this mode until another valid command is issued.

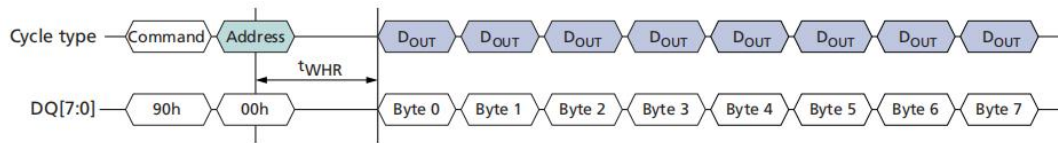
When the 90h command is followed by a 00h address cycle, the target returns a 5-byte identifier code that includes the manufacturer ID, device configuration, and part-specific information.

When the 90h command is followed by a 20h address cycle, the target returns the 4-byte ONFI identifier code.

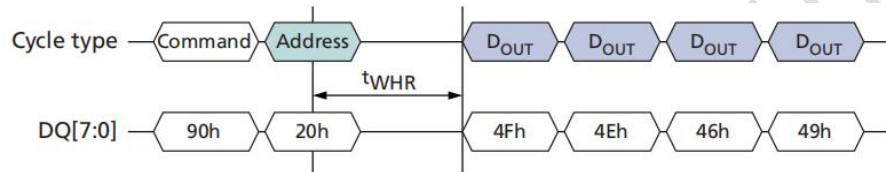
When the 90h command is followed by a 40h address cycle, the target returns the 5-byte JEDEC identifier code.

After the 90h and address cycle are written to the target, the host enables data output mode to read the identifier information. When the asynchronous interface is active, one data byte is output per RE# toggle.

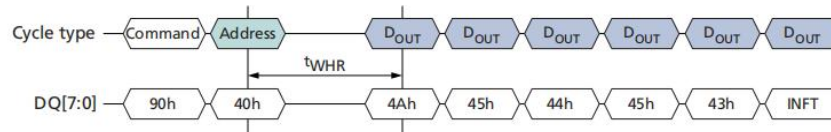
When the synchronous interface is active, one data byte is output per rising edge of DQS when ALE and CLE are HIGH; the data byte on the falling edge of DQS is identical to the data byte output on the previous rising edge of DQS.

Figure 28: READ ID (90h) with 00h Address Operation


Note: 1. See the READ ID Parameter tables for byte definitions.

Figure 29: READ ID (90h) with 20h Address Operation


Note: 1. See the READ ID Parameter tables for byte definitions.

Figure 30: READ ID (90h) with 40h Address Operation


Note: 1. See the READ ID Parameter tables for byte definitions.



16.2 READ ID Parameter Tables

Table 6: Read ID Parameters for Address 00h

Device	Byte 0	Byte 1	Byte 2	Byte 3	Byte 4	Byte 5	Byte 6	Byte 7
MT29F64G08CBABA	2Ch	64h	44h	4Bh	A9h	00h	00h	00h
MT29F64G08CBABB	2Ch	64h	44h	4Bh	A9h	00h	00h	00h
MT29F64G08CBCBB	2Ch	64h	44h	4Bh	A9h	00h	00h	00h
MT29F128G08CECBB	2Ch	64h	44h	4Bh	A9h	00h	00h	00h
MT29F128G08CFABA	2Ch	64h	44h	4Bh	A9h	00h	00h	00h
MT29F128G08CFABB	2Ch	64h	44h	4Bh	A9h	00h	00h	00h
MT29F256G08CJABB	2Ch	84h	C5h	4Bh	A9h	00h	00h	00h
MT29F256G08CKCBB	2Ch	84h	C5h	4Bh	A9h	00h	00h	00h
MT29F256G08CMCBB	2Ch	64h	44h	4Bh	A9h	00h	00h	00h
MT29F512G08CUCBB	2Ch	84h	C5h	4Bh	A9h	00h	00h	00h

Note: 1. h = hexadecimal.

Device	Byte 0	Byte 1	Byte 2	Byte 3	Byte 4
All	4Fh	4Eh	46h	49h	XXh

Table 7: Read ID Parameters for Address 20h

- Notes:
1. h = hexadecimal.
 2. XXh = Undefined.

Table 8: Read ID Parameters for Address 40h

Device	Byte 0	Byte 1	Byte 2	Byte 3	Byte 4	Byte 5
Asynchronous only	4Ah	45h	44h	45h	43h	01h
Asynchronous or Synchronous	4Ah	45h	44h	45h	43h	05h

Note: 1. h = hexadecimal.

16.3 READ PARAMETER PAGE (ECh)

The READ PARAMETER PAGE (ECh) command is used to read the ONFI or JEDEC parameter page programmed into the target. This command is accepted by the target only when all die (LUNs) on the target are idle.

Writing ECh to the command register puts the target in read parameter page mode. The target stays in this mode until another valid command is issued.

When the ECh command is followed by an 00h or 40h address cycle, the target goes busy for t_R . If the READ STATUS (70h) command is used to monitor for command completion, the READ MODE (00h) command must be used to re-enable data output mode. Use of the READ STATUS ENHANCED (78h) command is prohibited while the target is busy and during data output.

After t_R completes, the host enables data output mode to read the parameter page. When the asynchronous interface is active, one data byte is output per RE# toggle. When the synchronous interface is active, one data byte is output for each rising or falling edge of DQS.

A minimum of three copies of the parameter page are stored in the device. Each parameter page is 256 bytes. If desired, the CHANGE READ COLUMN (05h-E0h) command can be used to change the location of data output. Use of the CHANGE READ COLUMN ENHANCED (06h-E0h or 00h-05h-E0h) command is prohibited. The READ PARAMETER PAGE (ECh) output data can be used by the host to configure its internal settings to properly use the NAND Flash device. Parameter page data is static per part, however the value can be changed through the product cycle of NAND Flash. The host should interpret the data and configure itself accordingly.

Figure 31: READ PARAMETER (ECh) with 00h Address Operation for ONFI

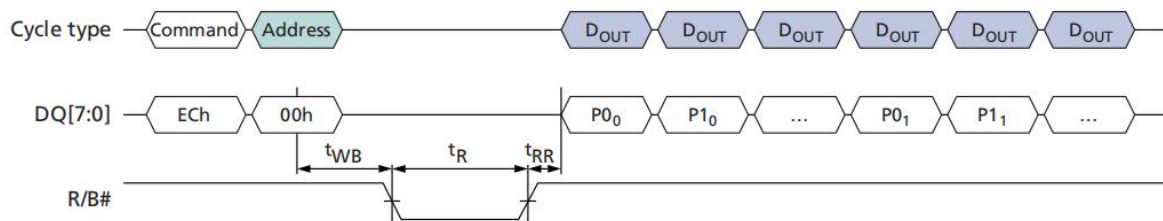
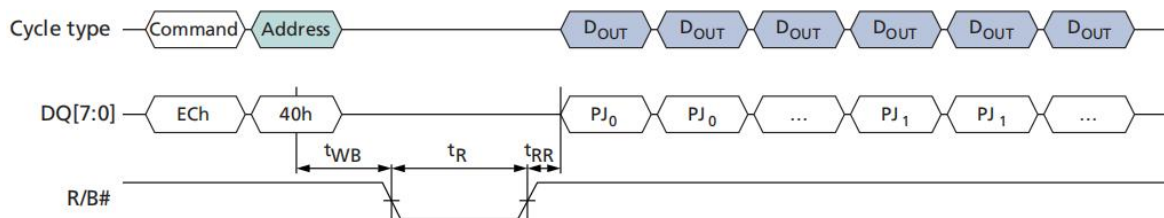


Figure 32: READ PARAMETER (ECh) with 40h Address Operation for JEDEC





Parameter Page Data Structure Tables

Table 9: Parameter Page Data Structure for ONFI

Byte	Description	Device	Values
Revision information and features block			
0-3	Parameter page signature Byte 0: 4Fh, "O" Byte 1: 4Eh, "N" Byte 2: 46h, "F" Byte 3: 49h, "I"	-	4Fh, 4Eh, 46h, 49h
4-5	Revision number Bit[15:6]: Reserved (0) Bit 5: 1 = supports ONFI version 2.3 Bit 4: 1 = supports ONFI version 2.2 Bit 3: 1 = supports ONFI version 2.1 Bit 2: 1 = supports ONFI version 2.0 Bit 1: 1 = supports ONFI version 1.0 Bit 0: Reserved (0)	-	3Eh, 00h
6-7	Features supported Bit[15:9]: Reserved (0) Bit 8: 1 = supports program page register clear enhancement Bit 7: 1 = supports extended parameter page Bit 6: 1 = supports multi-plane read operations Bit 5: 1 = supports synchronous interface Bit 4: 1 = supports odd-to-even page copyback Bit 3: 1 = supports multi-plane program and erase operations Bit 2: 1 = supports non-sequential page programming Bit 1: 1 = supports multiple LUN operations Bit 0: 1 = supports 16-bit data bus width	MT29F64G08CBABA	D8h, 01h
		MT29F128G08CFABA	
		MT29F256G08CJABA	DAh, 01h
		MT29F64G08CBABB	F8h, 01h
		MT29F64G08CBCBB	
		MT29F128G08CECBB	
		MT29F128G08CFABB	
		MT29F256G08CMCBB	FAh, 01h
		MT29F256G08CJABB	
		MT29F256G08CKCBB	
MT29F512G08CUCBB			
8-9	Optional commands supported Bit[15:10]: Reserved (0) Bit 9: 1 = supports Reset LUN command Bit 8: 1 = supports small data move Bit 7: 1 = supports CHANGE ROW ADDRESS Bit 6: 1 = supports CHANGE READ COLUMN ENHANCED Bit 5: 1 = supports READ UNIQUE ID Bit 4: 1 = supports COPYBACK Bit 3: 1 = supports READ STATUS ENHANCED Bit 2: 1 = supports GET FEATURES and SET FEATURES Bit 1: 1 = supports read cache commands Bit 0: 1 = supports PROGRAM PAGE CACHE	-	FFh, 03h
10-11	Reserved (0)	-	All 00h
12-13	Extended parameter page length	-	03h, 00h
14	Number of parameter pages	-	03h
15-31	Reserved (0)	-	All 00h



Table 9: Parameter Page Data Structure for ONFI (Continued)

Byte	Description	Device	Values
Manufacturer information block			
32–43	Device manufacturer (12 ASCII characters) Micron	–	4Dh, 49h, 43h, 52h, 4Fh, 4Eh, 20h, 20h, 20h, 20h, 20h, 20h
44–63	Device model (20 ASCII characters)	MT29F64G08CBABAWP	4Dh, 54h, 32h, 39h, 46h, 36h, 34h, 47h, 30h, 38h, 43h, 42h, 41h, 42h, 41h, 57h, 50h, 20h, 20h, 20h
		MT29F64G08CBABBWP	4Dh, 54h, 32h, 39h, 46h, 36h, 34h, 47h, 30h, 38h, 43h, 42h, 41h, 42h, 42h, 57h, 50h, 20h, 20h, 20h
		MT29F128G08CFABAWP	4Dh, 54h, 32h, 39h, 46h, 31h, 32h, 38h, 47h, 30h, 38h, 43h, 46h, 41h, 42h, 41h, 57h, 50h, 20h, 20h
		MT29F128G08CFABBWP	4Dh, 54h, 32h, 39h, 46h, 31h, 32h, 38h, 47h, 30h, 38h, 43h, 46h, 41h, 42h, 42h, 57h, 50h, 20h, 20h
		MT29F256G08CJABAWP	4Dh, 54h, 32h, 39h, 46h, 32h, 35h, 36h, 47h, 30h, 38h, 43h, 4Ah, 41h, 42h, 41h, 57h, 50h, 20h, 20h
		MT29F256G08CJABBWP	4Dh, 54h, 32h, 39h, 46h, 32h, 35h, 36h, 47h, 30h, 38h, 43h, 4Ah, 41h, 42h, 42h, 57h, 50h, 20h, 20h



Table 9: Parameter Page Data Structure for ONFI (Continued)

Byte	Description	Device	Values
44–63	Device model (20 ASCII characters)	MT29F64G08CBCBBH1	4Dh, 54h, 32h, 39h, 46h, 36h, 34h, 47h, 30h, 38h, 43h, 42h, 43h, 42h, 42h, 48h, 31h, 20h, 20h, 20h
		MT29F128G08CECBBH1	4Dh, 54h, 32h, 39h, 46h, 31h, 32h, 38h, 47h, 30h, 38h, 43h, 45h, 43h, 42h, 42h, 48h, 31h, 20h, 20h
		MT29F256G08CKCBBH2	4Dh, 54h, 32h, 39h, 46h, 32h, 35h, 36h, 47h, 30h, 38h, 43h, 4Bh, 43h, 42h, 42h, 48h, 32h, 20h, 20h
		MT29F256G08CMCBBH2	4Dh, 54h, 32h, 39h, 46h, 32h, 35h, 36h, 47h, 30h, 38h, 43h, 4Dh, 43h, 42h, 42h, 48h, 32h, 20h, 20h
		MT29F512G08CUCBBH3	4Dh, 54h, 32h, 39h, 46h, 35h, 31h, 32h, 47h, 30h, 38h, 43h, 55h, 43h, 42h, 42h, 48h, 33h, 20h, 20h
64	JEDEC manufacturer ID	–	2Ch
65–66	Date code	–	00h, 00h
67–79	Reserved (0)	–	All 00h
Memory organization block			
80–83	Number of data bytes per page	–	00h, 20h, 00h, 00h
84–85	Number of spare bytes per page	–	E8h, 02h
86–91	Reserved (0)	–	All 00h
92–95	Number of pages per block	–	00h, 01h, 00h, 00h
96–99	Number of blocks per LUN	–	00h, 10h, 00h, 00h



Table 9: Parameter Page Data Structure for ONFI (Continued)

Byte	Description	Device	Values
100	Number of LUNs per chip enable	MT29F64G08CBABA	01h
		MT29F64G08CBABB	
		MT29F64G08CBCBB	
		MT29F128G08CECBB	
		MT29F128G08CFABA	
		MT29F128G08CFABB	
		MT29F256G08CMCBB	
		MT29F256G08CJABA	02h
		MT29F256G08CJABB	
		MT29F256G08CKCBB	
		MT29F512G08CUCBB	
101	Number of address cycles Bit[7:4]: Column address cycles Bit[3:0]: Row address cycles	-	23h
102	Number of bits per cell	-	02h
103-104	Bad blocks maximum per LUN	-	64h, 00h
105-106	Block endurance	-	03h, 03h
107	Guaranteed valid blocks at beginning of target	-	01h
108-109	Block endurance for guaranteed valid blocks	-	00h, 00h
110	Number of programs per page	-	01h
111	Reserved (0)	-	00h
112	Number of bits ECC correctability	-	FFh
113	Number of plane address bits	-	01h
	Bit[7:4]: Reserved (0) Bit[3:0]: Number of interleaved address bits		
114	Multi-plane operation attributes	-	1Eh
	Bit[7:6]: Reserved (0)		
	Bit 5: Reserved		
	Bit 4: 1 = supports read cache		
	Bit 3: Address restrictions for cache operations		
	Bit 2: 1 = supports program cache Bit 1: 1 = no block address restrictions Bit 0: Overlapped/concurrent interleaving support		
115-127	Reserved (0)	-	All 00h
Electrical parameters block			



Table 9: Parameter Page Data Structure for ONFI (Continued)

Byte	Description	Device	Values
128	I/O pin capacitance per chip enable	MT29F64G08CBABAWP	06h
		MT29F64G08CBABBWP	
		MT29F128G08CFABAWP	05h
		MT29F128G08CFABBWP	
		MT29F256G08CJABAWP	09h
		MT29F256G08CJABBWP	
		MT29F64G08CBCBBH1	05h
		MT29F128G08CECBBH1	05h
		MT29F256G08CKCBBH2	0Ah
		MT29F256G08CMCBBH2	05h
		MT29F512G08CUCBBH3	09h
129–130	Timing mode support Bit[15:6]: Reserved (0) Bit 5: 1 = supports timing mode 5 Bit 4: 1 = supports timing mode 4 Bit 3: 1 = supports timing mode 3 Bit 2: 1 = supports timing mode 2 Bit 1: 1 = supports timing mode 1 Bit 0: 1 = supports timing mode 0, shall be 1	–	3Fh, 00h
131–132	Reserved (0)	–	All 00h
133–134	tPROG Maximum PROGRAM PAGE time (μ s)	–	C4h, 09h
135–136	tBERS Maximum BLOCK ERASE time (μ s)	–	10h, 27h
137–138	tR Maximum PAGE READ time (μ s)	–	4Bh, 00h
139–140	tCCS Minimum change column setup time (ns)	–	C8h, 00h
141–142	Source synchronous timing mode support Bit[15:6]: Reserved (0) Bit 5: 1 = supports timing mode 5 Bit 4: 1 = supports timing mode 4 Bit 3: 1 = supports timing mode 3 Bit 2: 1 = supports timing mode 2 Bit 1: 1 = supports timing mode 1 Bit 0: 1 = supports timing mode 0	MT29F64G08CBABAWP	00h, 00h
		MT29F128G08CFABAWP	
		MT29F256G08CJABAWP	
		MT29F64G08CBABBWP	1Fh, 00h
		MT29F128G08CFABBWP	
		MT29F256G08CJABBWP	
		MT29F64G08CBCBBH1	3Fh, 00h
		MT29F128G08CECBBH1	
		MT29F256G08CKCBBH2	
		MT29F256G08CMCBBH2	
		MT29F512G08CUCBBH3	



Table 9: Parameter Page Data Structure for ONFI (Continued)

Byte	Description	Device	Values
143	Source synchronous features Bit[7:3]: Reserved (0) Bit 2: 1 = devices support CLK stopped for data input Bit 1: 1 = typical capacitance values present Bit 0: 0 = use tCAD MIN value	MT29F64G08CBABAWP	00h
		MT29F128G08CFABAWP	
		MT29F256G08CJABAWP	
		02h	MT29F64G08CBABBWP
			MT29F128G08CFABBWP
			MT29F256G08CJABBWP
			MT29F64G08CBCBBH1
			MT29F128G08CECBBH1
			MT29F256G08CKCBBH2
			MT29F256G08CMCBBH2
			MT29F512G08CUCBBH3
144–145	CLK input pin capacitance, typical	MT29F64G08CBABAWP	00h, 00h
		MT29F128G08CFABAWP	
		MT29F256G08CJABAWP	
		27h, 00h	MT29F64G08CBABBWP
		21h, 00h	MT29F128G08CFABBWP
		38h, 00h	MT29F256G08CJABBWP
		28h, 00h	MT29F64G08CBCBBH1
			MT29F128G08CECBBH1
		3Eh, 00h	MT29F256G08CKCBBH2
		1Fh, 00h	MT29F256G08CMCBBH2
		35h, 00h	MT29F512G08CUCBBH3
146–147	I/O pin capacitance, typical	MT29F64G08CBABAWP	00h, 00h
		MT29F128G08CFABAWP	
		MT29F256G08CJABAWP	
		30h, 00h	MT29F64G08CBABBWP
		2Ah, 00h	MT29F128G08CFABBWP
		49h, 00h	MT29F256G08CJABBWP
		2Dh, 00h	MT29F64G08CBCBBH1
			MT29F128G08CECBBH1
		50h, 00h	MT29F256G08CKCBBH2
		28h, 00h	MT29F256G08CMCBBH2
		49h, 00h	MT29F512G08CUCBBH3



Table 9: Parameter Page Data Structure for ONFI (Continued)

Byte	Description	Device	Values
148–149	Input capacitance, typical	MT29F64G08CBABAWP	00h, 00h
		MT29F128G08CFABAWP	
		MT29F256G08CJABAWP	
		MT29F64G08CBABBWP	2Dh, 00h
		MT29F128G08CFABBWP	24h, 00h
		MT29F256G08CJABBWP	3Dh, 00h
		MT29F64G08CBCBBH1	28h, 00h
		MT29F128G08CECBBH1	
		MT29F256G08CKCBBH2	44h, 00h
		MT29F256G08CMCBBH2	22h, 00h
		MT29F512G08CUCBBH3	35h, 00h
150	Input pin capacitance, maximum	MT29F64G08CBABAWP	0Ah
		MT29F64G08CBABBWP	07h
		MT29F128G08CFABAWP	
		MT29F128G08CFABBWP	09h
		MT29F256G08CJABAWP	
		MT29F256G08CJABBWP	05h
		MT29F64G08CBCBBH1	
		MT29F128G08CECBBH1	08h
		MT29F256G08CKCBBH2	
		MT29F256G08CMCBBH2	04h
		MT29F512G08CUCBBH3	07h
151	Driver strength support Bit[7:3]: Reserved (0) Bit 2: 1 = Supports 18 Ohm drive strength Bit 1: 1 = Supports 25 Ohm drive strength Bit 0: 1 = Supports driver strength settings	–	07h
152–153	t _R maximum multi-plane page read time (μs)	–	4Bh, 00h
154-155	t _{ADL} program page register clear enhancement value (ns)	–	46h, 00h
156–163	Reserved (0)	–	All 00h
Vendor block			
164–165	Vendor-specific revision number	–	01h, 00h
166	TWO-PLANE PAGE READ support Bit[7:1]: Reserved (0) Bit 0: 1 = Support for TWO-PLANE PAGE READ	–	01h
167	Read cache support Bit[7:1]: Reserved (0) Bit 0: 0 = Does not support Micron-specific read cache function	–	00h



Table 9: Parameter Page Data Structure for ONFI (Continued)

Byte	Description	Device	Values
168	READ UNIQUE ID support Bit[7:1]: Reserved (0) Bit 0: 0 = Does not support Micron-specific READ UNIQUE ID	-	00h
169	Programmable DQ output impedance support Bit[7:1]: Reserved (0) Bit 0: 0 = No support for programmable DQ output impedance by B8h command	-	00h
170	Number of programmable DQ output impedance settings Bit[7:3]: Reserved (0) Bit [2:0] = Number of programmable DQ output impedance settings	-	04h
171	Programmable DQ output impedance feature address Bit[7:0] = Programmable DQ output impedance feature address	-	10h
172	Programmable R/B# pull-down strength support Bit[7:1]: Reserved (0) Bit 0: 1 = Support programmable R/B# pull-down strength	-	01h
173	Programmable R/B# pull-down strength feature address Bit[7:0] = Feature address used with programmable R/B# pull-down strength	-	81h
174	Number of programmable R/B# pull-down strength settings Bit[7:3]: Reserved (0) Bit[2:0] = Number of programmable R/B# pull-down strength settings	-	04h
175	OTP mode support Bit[7:2]: Reserved (0) Bit 1: 1 = Supports Get/Set Features command set Bit 0: 0 = Does not support A5h/A0h/AFh OTP command set	-	02h
176	OTP page start Bit[7:0] = Page where OTP page space begins	-	02h
177	OTP DATA PROTECT address Bit[7:0] = Page address to use when issuing OTP DATA PROTECT command	-	01h
178	Number of OTP pages Bit[15:5]: Reserved (0) Bit[4:0] = Number of OTP pages	-	1Eh
179	OTP Feature Address	-	90h
180-252	Reserved (0)	-	All 00h



Table 9: Parameter Page Data Structure for ONFI (Continued)

Byte	Description	Device	Values
253	Parameter page revision	MT29F64G08CBABAWP	01h
		MT29F64G08CBABBWP	
		MT29F128G08CFABAWP	
		MT29F128G08CFABBWP	
		MT29F256G08CJABAWP	
		MT29F256G08CJABBWP	
		MT29F64G08CBCBBH1	
		MT29F128G08CECBBH1	
		MT29F256G08CKCBBH2	
		MT29F256G08CMCBBH2	
		MT29F512G08CUCBBH3	
254–255	Integrity CRC	MT29F64G08CBABAWP	90h, ECh
		MT29F64G08CBABBWP	F2h, 4Fh
		MT29F128G08CFABAWP	D6h, B9h
		MT29F128G08CFABBWP	C1h, D6h
		MT29F256G08CJABAWP	D3h, C4h
		MT29F256G08CJABBWP	99h, 9Ah
		MT29F64G08CBCBBH1	1Dh, C0h
		MT29F128G08CECBBH1	BFh, 9Eh
		MT29F256G08CKCBBH2	88h, A0h
		MT29F256G08CMCBBH2	26h, E7h
		MT29F512G08CUCBBH3	98h, EAh
Redundant ONFI parameter pages			
256–511	Value of bytes 0–255	–	See bytes 0–255
512–767	Value of bytes 0–255	–	See bytes 0–255
Extended parameter pages			
768–769	Extended parameter page Integrity CRC	–	1Ch, D1h
770–773	Extended parameter page signature Byte 0: 45h, “E” Byte 1: 50h, “P” Byte 2: 50h, “P” Byte 3: 53h, “S”	–	45h, 50h, 50h, 53h
774–783	Reserved (0)	–	All 00h
784	Section 0 type	–	02h
785	Section 0 length	–	01h
786–799	Reserved (0)	–	All 00h
800	Number of bits ECC correctability	–	28h
801	ECC codeword size	–	0Ah
802–803	Bad blocks maximum per LUN	–	64h, 00h



Table 9: Parameter Page Data Structure for ONFI (Continued)

Byte	Description	Device	Values
804-805	Block endurance	–	03h, 03h
806-815	Reserved (0)	–	All 00h
816-863	Value of bytes 768-815	–	See bytes 768-815
864-911	Value of bytes 768-815	–	See bytes 768-815

Table 10: Parameter Page Data Structure for JEDEC

Byte	Description	Device	Values
Revision Information and Features Block			
0-511	JEDEC specific read parameter page information	–	TBD
Redundant JEDEC Parameter Pages			
512-767	Value of bytes 0-511	–	See bytes 0-511
768-911	Value of bytes 0-511	–	See bytes 0-511

16.4 READ UNIQUE ID (EDh)

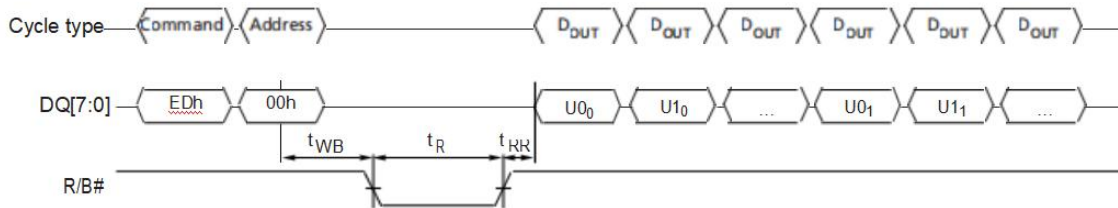
The READ UNIQUE ID (EDh) command is used to read a unique identifier programmed into the target. This command is accepted by the target only when all die (LUNs) on the target are idle.

Writing EDh to the command register puts the target in read unique ID mode. The target stays in this mode until another valid command is issued.

When the EDh command is followed by a 00h address cycle, the target goes busy for tR. If the READ STATUS (70h) command is used to monitor for command completion, the READ MODE (00h) command must be used to re-enable data output mode.

After tR completes, the host enables data output mode to read the unique ID. When the asynchronous interface is active, one data byte is output per RE# toggle. When the synchronous interface is active, two data bytes are output, one byte for each rising or falling edge of DQS.

Sixteen copies of the unique ID data are stored in the device. Each copy is 32 bytes. The first 16 bytes of a 32-byte copy are unique data, and the second 16 bytes are the complement of the first 16 bytes. The host should XOR the first 16 bytes with the second 16 bytes. If the result is 16 bytes of FFh, then that copy of the unique ID data is correct. In the event that a non FFh result is returned, the host can repeat the XOR operation on a subsequent copy of the unique ID data. If desired, the CHANGE READ COLUMN (05h- E0h) command can be used to change the data output location. Use of the CHANGE READ COLUMN ENHANCED (06h-E0h) command is prohibited.

Figure 33: READ UNIQUE ID (EDh) Operation


17 Configuration Operations

The SET FEATURES (EFh) and GET FEATURES (EEh) commands are used to modify the target's default power-on behavior. These commands use a one-byte feature address to determine which subfeature parameters will be read or modified. Each feature address (in the 00h to FFh range) is defined in . The SET FEATURES (EFh) command writes sub- feature parameters (P1-P4) to the specified feature address. The GET FEATURES command reads the subfeature parameters (P1-P4) at the specified feature address. Unless otherwise specified, the values of the feature addresses do not change when RESET (FFh, FCh) is issued by the host.

Table 11: Feature Address Definitions

Feature Address	Definition
00h	Reserved
01h	Timing mode
02h–0Fh	Reserved
10h	Programmable output drive strength
11h–7Fh	Reserved
80h	Programmable output drive strength
81h	Programmable RB# pull-down strength
82h–88h	Reserved
89h	Read Retry
8Ah–8Fh	Reserved
90h	Array operation mode
91h–FFh	Reserved

17.1 SET FEATURES (EFh)

The SET FEATURES (EFh) command writes the subfeature parameters (P1-P4) to the specified feature address to enable or disable target-specific features. This command is accepted by the target only when all die (LUNs) on the target are idle.

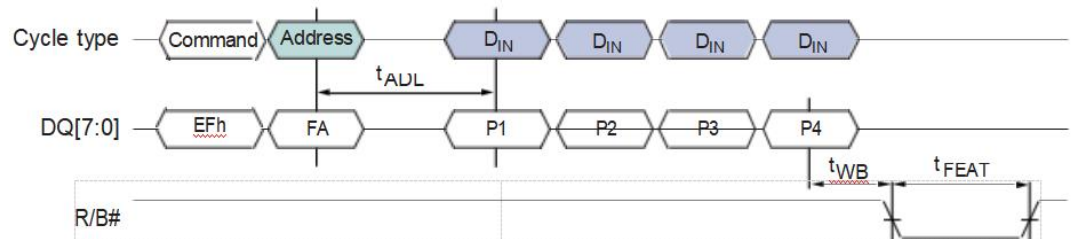
Writing EFh to the command register puts the target in the set features mode. The target stays in this mode until another command is issued.

The EFh command is followed by a valid feature address as specified in . The host waits for t_{ADL} before the subfeature parameters are input. When the asynchronous interface is active, one subfeature parameter is latched per rising edge of WE#. When the synchronous interface is active, one subfeature parameter is latched per rising edge of DQS. The data on the falling edge of DQS should be identical to the subfeature parameter input on the previous rising edge of DQS. The device is not required to wait for the repeated data byte before beginning internal actions.

After all four subfeature parameters are input, the target goes busy for t_{FEAT} . The READ STATUS (70h) command can be used to monitor for command completion.

Feature address 01h (timing mode) operation is unique. If SET FEATURES is used to modify the interface type, the target will be busy for t_{ITC} . See Activating Interfaces (page 44) for details.

Figure 34: SET FEATURES (EFh) Operation



17.2 GET FEATURES (EEh)

The GET FEATURES (EEh) command reads the subfeature parameters (P1-P4) from the specified feature address. This command is accepted by the target only when all die (LUNs) on the target are idle.

Writing EEh to the command register puts the target in get features mode. The target stays in this mode until another valid command is issued.

When the EEh command is followed by a feature address, the target goes busy for t_{FEAT} . If the READ STATUS (70h) command is used to monitor for command completion, the READ MODE (00h) command must be used to re-enable data output mode. During and prior to data output, use of the READ STATUS ENHANCED (78h) command is prohibited.

After t_{FEAT} completes, the host enables data output mode to read the subfeature parameters. When the asynchronous interface is active, one data byte is output per RE# toggle. When the synchronous interface is active, one subfeature parameter is output per DQS toggle on rising or falling edge of DQS.

Figure 35: GET FEATURES (EEh) Operation

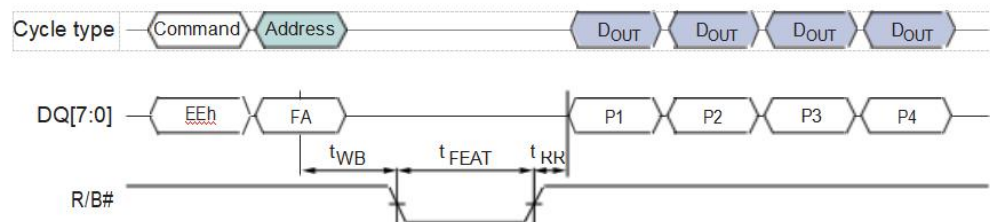




Table 12: Feature Address 01h: Timing Mode

Subfeature Parameter	Options	DQ7	DQ6	DQ5	DQ4	DQ3	DQ2	DQ1	DQ0	Value	Notes
P1											
Timing mode	Mode 0 (default)					0	0	0	0	x0h	1, 2
	Mode 1					0	0	0	1	x1h	
	Mode 2					0	0	1	0	x2h	
	Mode 3					0	0	1	1	x3h	
	Mode 4					0	1	0	0	x4h	
	Mode 5					0	1	0	1	x5h	
Data interface	Asynchronous (default)			0	0					0xh	1
	Synchronous DDR			0	1					1xh	
	Reserved			1	x					2xh	
Program clear	Program command clears all cache registers on a target (default)		0							0b	
	Program command clears only addressed LUN cache register on a target		1							1b	
Reserved		0								0b	
P2											
Reserved		0	0	0	0	0	0	0	0	00h	
P3											
Reserved		0	0	0	0	0	0	0	0	00h	
P4											
Reserved		0	0	0	0	0	0	0	0	00h	

Notes:

- Asynchronous timing mode 0 is the default, power-on value.
- If the synchronous interface is active, a RESET (FFh) command will change the timing mode and data interface bits of feature address 01h to their default values. If the asynchronous interface is active, a RESET (FFh) command will not change the values of the timing mode or data interface bits to their default values.



Table 13: Feature Addresses 10h and 80h: Programmable Output Drive Strength

Subfeature Parameter	Options	DQ7	DQ6	DQ5	DQ4	DQ3	DQ2	DQ1	DQ0	Value	Notes
P1											
Output drive strength	Overdrive 2							0	0	00h	1
	Overdrive 1							0	1	01h	
	Nominal (default)							1	0	02h	
	Underdrive							1	1	03h	
Reserved		0	0	0	0	0	0			00h	
P2											
Reserved		0	0	0	0	0	0	0	0	00h	
P3											
Reserved		0	0	0	0	0	0	0	0	00h	
P4											
Reserved		0	0	0	0	0	0	0	0	00h	

Note: 1. See Output Drive Strength Impedance Values ($V_{CCQ} = 2.7\text{--}3.6\text{V}$) table for details.

Table 14: Feature Addresses 81h: Programmable R/B# Pull-Down Strength

Subfeature Parameter	Options	DQ7	DQ6	DQ5	DQ4	DQ3	DQ2	DQ1	DQ0	Value	Notes
P1											
R/B# pull-down strength	Full (default)							0	0	00h	1
	Three-quarter							0	1	01h	
	One-half							1	0	02h	
	One-quarter							1	1	03h	
Reserved		0	0	0	0	0	0			00h	
P2											
Reserved		0	0	0	0	0	0	0	0	00h	
P3											
Reserved		0	0	0	0	0	0	0	0	00h	
P4											
Reserved		0	0	0	0	0	0	0	0	00h	

Note:

1. This feature address is used to change the default R/B# pull-down strength. Its strength should be selected based on the expected loading of R/B#. Full strength is the default, power-on value.



Table 15: Feature Addresses 89h: Read Retry

Subfeature Parameter	Options	DQ7	DQ6	DQ5	DQ4	DQ3	DQ2	DQ1	DQ0	Value	Notes
P1											
Read Retry	Disable (default)							0	0	00h	
	Option 1							0	1	01h	
	Option 2							1	0	02h	
	Option 3							1	1	03h	
Reserved		0	0	0	0	0	0			00h	
P2											
Reserved		0	0	0	0	0	0	0	0	00h	
P3											
Reserved		0	0	0	0	0	0	0	0	00h	
P4											
Reserved		0	0	0	0	0	0	0	0	00h	

Note: 1. See Read Retry Operation for details.

Table 16: Feature Addresses 90h: Array Operation Mode

Subfeature Parameter	Options	DQ7	DQ6	DQ5	DQ4	DQ3	DQ2	DQ1	DQ0	Value	Notes
P1											
Array Operation Mode	Normal (default)								0	00h	
	OTP Block								1	01h	1
Reserved		0	0	0	0	0	0	0		00h	
P2											
Reserved		0	0	0	0	0	0	0	0	00h	
P3											
Reserved		0	0	0	0	0	0	0	0	00h	
P4											
Reserved		0	0	0	0	0	0	0	0	00h	

Notes:

1. See One-Time Programmable (OTP) Operations for details.
2. A RESET (FFh) command will cause the bits of the array operation mode to change to their default values.



18 Status Operations

Each die (LUN) provides its status independently of other die (LUNs) on the same target through its 8-bit status register.

After the READ STATUS (70h) or READ STATUS ENHANCED (78h) command is issued, status register output is enabled. The contents of the status register are returned on DQ[7:0] for each data output request. When the asynchronous interface is active and status register output is enabled, changes in the status register are seen on DQ[7:0] as long as CE# and RE# are LOW; it is not necessary to toggle RE# to see the status register update.

When the synchronous interface is active and status register output is enabled, changes in the status register are seen on DQ[7:0] as long as CE# and W/R# are LOW and ALE and CLE are HIGH. DQS also toggles while ALE and CLE are HIGH.

While monitoring the status register to determine when a data transfer from the Flash array to the data register (tR) is complete, the host must issue the READ MODE (00h) command to disable the status register and enable data output (see READ MODE (00h) (page 82)).

The READ STATUS (70h) command returns the status of the most recently selected die (LUN). To prevent data contention during or following an interleaved die (multi-LUN) operation, the host must enable only one die (LUN) for status output by using the READ STATUS ENHANCED (78h) command (see Interleaved Die (Multi-LUN) Operations (page 109)).



Table 17: Status Register Definition

SR Bit	Definition	Independent per Plane ¹	Description
7	WP#	–	Write Protect: 0 = Protected 1 = Not protected In the normal array mode, this bit indicates the value of the WP# signal. In OTP mode this bit is set to 0 if a PROGRAM OTP PAGE operation is attempted and the OTP area is protected.
6	RDY	–	Ready/Busy I/O: 0 = Busy 1 = Ready This bit indicates that the selected die (LUN) is not available to accept new commands, address, or data I/O cycles with the exception of RESET (FFh), SYNCHRONOUS RESET (FCh), READ STATUS (70h), and READ STATUS ENHANCED (78h). This bit applies only to the selected die (LUN).
5	ARDY	–	Ready/Busy Array: 0 = Busy 1 = Ready This bit goes LOW (busy) when an array operation is occurring on any plane of the selected die (LUN). It goes HIGH when all array operations on the selected die (LUN) finish. This bit applies only to the selected die (LUN).
4	–	–	Reserved (0)
3	–	–	Reserved (0)



Table 17: Status Register Definition (Continued)

SR Bit	Definition	Independent per Plane ¹	Description
2	–	–	Reserved (0)
1	FAILC	Yes	Pass/Fail (N–1): 0 = Pass 1 = Fail This bit is set if the previous operation on the selected die (LUN) failed. This bit is valid only when RDY (SR bit 6) is 1. It applies to PROGRAM-, and COPYBACK PROGRAM-series operations (80h-10h, 80h-15h, 85h-10h). This bit is not valid following an ERASE-series or READ-series operation.
0	FAIL	Yes	Pass/Fail (N): 0 = Pass 1 = Fail This bit is set if the most recently finished operation on the selected die (LUN) failed. This bit is valid only when ARDY (SR bit 5) is 1. It applies to PROGRAM-, ERASE-, and COPYBACK PROGRAM-series operations (80h-10h, 80h-15h, 60h-D0h, 85h-10h). This bit is not valid following a READ-series operation.

Note: 1. After a multi-plane operation begins, the FAILC and FAIL bits are OR ed together for the active planes when the READ STATUS (70h) command is issued. After the READ STATUS ENHANCED (78h) command is issued, the FAILC and FAIL bits reflect the status of the plane selected.

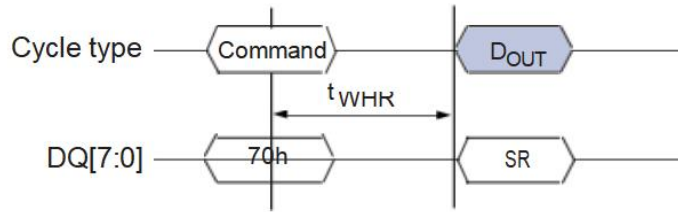
18.1 READ STATUS (70h)

The READ STATUS (70h) command returns the status of the last-selected die (LUN) on a target. This command is accepted by the last-selected die (LUN) even when it is busy (RDY = 0).

If there is only one die (LUN) per target, the READ STATUS (70h) command can be used to return status following any NAND command.

In devices that have more than one die (LUN) per target, during and following interleaved die (multi-LUN) operations, the READ STATUS ENHANCED (78h) command must be used to select the die (LUN) that should report status. In this situation, using the READ STATUS (70h) command will result in bus contention, as two or more die (LUNs) could respond until the next operation is issued. The READ STATUS (70h) command can be used following all single die (LUN) operations.

If following a multi-plane operation, regardless of the number of LUNs per target, the READ STATUS (70h) command indicates an error occurred (FAIL = 1), use the READ STATUS ENHANCED (78h) command—once for each plane—to determine which plane operation failed.

Figure 36: READ STATUS (70h) Operation


18.2 READ STATUS ENHANCED (78h)

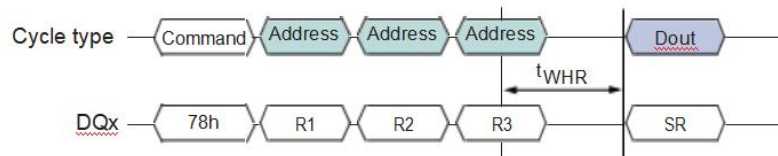
The READ STATUS ENHANCED (78h) command returns the status of the addressed die (LUN) on a target even when it is busy (RDY = 0). This command is accepted by all die (LUNs), even when they are BUSY (RDY = 0).

Writing 78h to the command register, followed by three row address cycles containing the page, block, and LUN addresses, puts the selected die (LUN) into read status mode. The selected die (LUN) stays in this mode until another valid command is issued. Die (LUNs) that are not addressed are deselected to avoid bus contention.

The selected LUN's status is returned when the host requests data output. The RDY and ARDY bits of the status register are shared for all of the planes of the selected die (LUN). The FAILC and FAIL bits are specific to the plane specified in the row address.

The READ STATUS ENHANCED (78h) command also enables the selected die (LUN) for data output. To begin data output following a READ-series operation after the selected die (LUN) is ready (RDY = 1), issue the READ MODE (00h) command, then begin data output. If the host needs to change the cache register that will output data, use the CHANGE READ COLUMN ENHANCED (06h-E0h) command after the die (LUN) is ready (see CHANGE READ COLUMN ENHANCED (06h-E0h)).

Use of the READ STATUS ENHANCED (78h) command is prohibited during the power-on RESET (FFh) command and when OTP mode is enabled. It is also prohibited following some of the other reset, identification, and configuration operations. See individual operations for specific details.

Figure 37: READ STATUS ENHANCED (78h) Operation


19 Column Address Operations

The column address operations affect how data is input to and output from the cache registers within the selected die (LUNs). These features provide host flexibility for managing data, especially when the host internal buffer is smaller than the number of data bytes or words in the cache register.

When the asynchronous interface is active, column address operations can address any byte in the selected cache register.

When the synchronous interface is active, column address operations are aligned to word boundaries (CA0 is forced to 0), because as data is transferred on DQ[7:0] in two-byte units.

19.1 CHANGE READ COLUMN (05h-E0h)

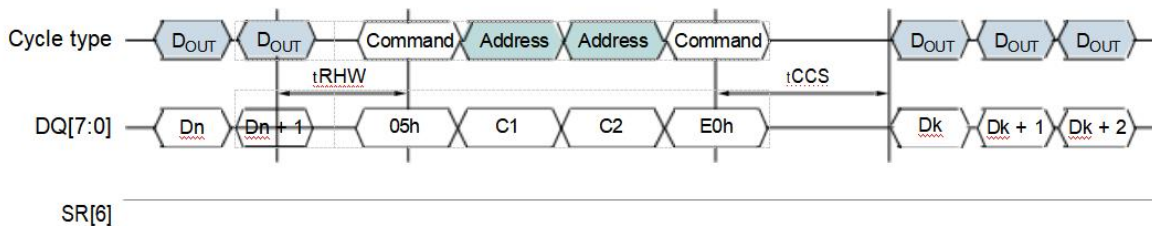
The CHANGE READ COLUMN (05h-E0h) command changes the column address of the selected cache register and enables data output from the last selected die (LUN). This command is accepted by the selected die (LUN) when it is ready (RDY = 1; ARDY = 1). It

is also accepted by the selected die (LUN) during CACHE READ operations (RDY = 1; ARDY = 0).

Writing 05h to the command register, followed by two column address cycles containing the column address, followed by the E0h command, puts the selected die (LUN) into data output mode. After the E0h command cycle is issued, the host must wait at least t_{CCS} before requesting data output. The selected die (LUN) stays in data output mode until another valid command is issued.

In devices with more than one die (LUN) per target, during and following interleaved die (multi-LUN) operations, the READ STATUS ENHANCED (78h) command must be issued prior to issuing the CHANGE READ COLUMN (05h-E0h). In this situation, using the CHANGE READ COLUMN (05h-E0h) command without the READ STATUS ENHANCED (78h) command will result in bus contention, as two or more die (LUNs) could output data.

Figure 38: CHANGE READ COLUMN (05h-E0h) Operation



19.2 CHANGE READ COLUMN ENHANCED (06h-E0h)

The CHANGE READ COLUMN ENHANCED (06h-E0h) command enables data output on the addressed die's (LUN's) cache register at the specified column address. This command is accepted by a die (LUN) when it is ready (RDY = 1; ARDY = 1).

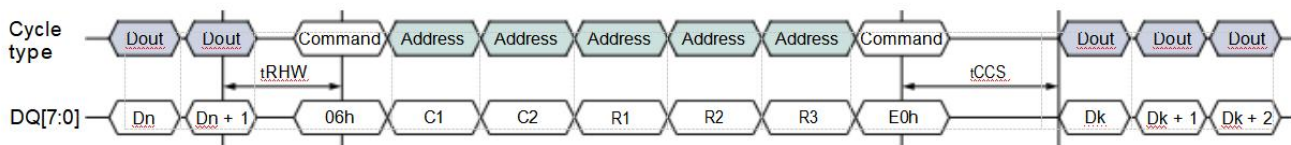
Writing 06h to the command register, followed by two column address cycles and three row address cycles, followed by E0h, enables data output mode on the address LUN's cache register at the specified column address. After the E0h command cycle is issued, the host must wait at least t_{CCS} before requesting data output. The selected die (LUN) stays in data output mode until another valid command is issued.

Following a multi-plane read page operation, the CHANGE READ COLUMN ENHANCED (06h-E0h) command is used to select the cache register to be enabled for data output. After data output is complete on the selected plane, the command can be issued again to begin data output on another plane.

In devices with more than one die (LUN) per target, after all of the die (LUNs) on the target are ready (RDY = 1), the CHANGE READ COLUMN ENHANCED (06h-E0h) command can be used following an interleaved die (multi-LUN) read operation. Die (LUNs) that are not addressed are deselected to avoid bus contention. In devices with more than one die (LUN) per target, during interleaved die (multi-LUN) operations where more than one or more die (LUNs) are busy (RDY = 1; ARDY = 0 or RDY = 0; ARDY = 0), the READ STATUS ENHANCED (78h) command must be issued to the die (LUN) to be selected prior to issuing the CHANGE READ COLUMN ENHANCED (06h-E0h). In this situation, using the CHANGE READ COLUMN ENHANCED (06h-E0h) command without the READ STATUS ENHANCED (78h) command will result in bus contention, as two or more die (LUNs) could output data.

If there is a need to update the column address without selecting a new cache register or LUN, the CHANGE READ COLUMN (05h-E0h) command can be used instead.

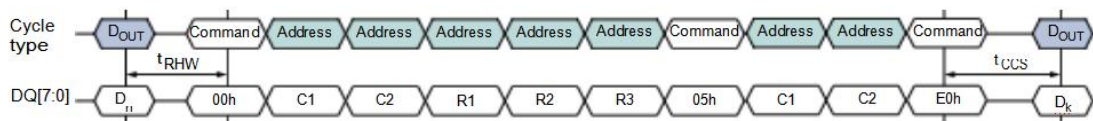
Figure 39: CHANGE READ COLUMN ENHANCED (06h-E0h) Operation



CHANGE READ COLUMN ENHANCED (00h-05h-E0h) Operation

This operation behaves the same as the CHANGE READ COLUMN ENHANCED (06h-E0h) command.

Figure 40: CHANGE READ COLUMN ENHANCED (00h-05h-E0h) Operation



19.3 CHANGE WRITE COLUMN (85h)

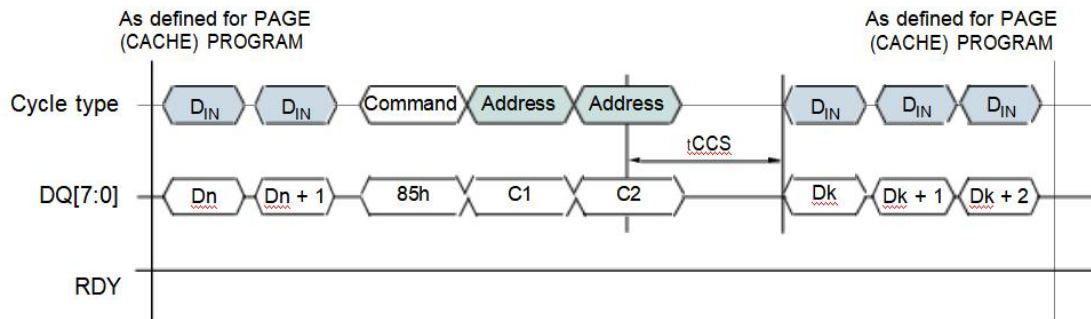
The CHANGE WRITE COLUMN (85h) command changes the column address of the selected cache register and enables data input on the last-selected die (LUN). This command is accepted by the selected die (LUN) when it is ready (RDY = 1; ARDY = 1). It is

also accepted by the selected die (LUN) during cache program operations (RDY = 1; ARDY = 0).

Writing 85h to the command register, followed by two column address cycles containing the column address, puts the selected die (LUN) into data input mode. After the second address cycle is issued, the host must wait at least t_{CCS} before inputting data. The selected die (LUN) stays in data input mode until another valid command is issued. Though data input mode is enabled, data input from the host is optional. Data input begins at the column address specified.

The CHANGE WRITE COLUMN (85h) command is allowed after the required address cycles are specified, but prior to the final command cycle (10h, 11h, 15h) of the following commands while data input is permitted: PROGRAM PAGE (80h-10h), PROGRAM PAGE MULTI-PLANE (80h-11h), PROGRAM PAGE CACHE (80h-15h), COPYBACK PROGRAM (85h-10h), and COPYBACK PROGRAM MULTI-PLANE (85h-11h). In devices that have more than one die (LUN) per target, the CHANGE WRITE COLUMN (85h) command can be used with other commands that support interleaved die (multi-LUN) operations.

Figure 41: CHANGE WRITE COLUMN (85h) Operation





19.4 CHANGE ROW ADDRESS (85h)

The CHANGE ROW ADDRESS (85h) command changes the row address (block and page) where the cache register contents will be programmed in the NAND Flash array. It also changes the column address of the selected cache register and enables data input on the specified die (LUN). This command is accepted by the selected die (LUN) when it is ready (RDY = 1; ARDY = 1). It is also accepted by the selected die (LUN) during cache programming operations (RDY = 1; ARDY = 0).

Write 85h to the command register. Then write two column address cycles and three row address cycles. This updates the page and block destination of the selected plane for the addressed LUN and puts the cache register into data input mode. After the fifth address cycle is issued the host must wait at least tCCS before inputting data. The selected LUN stays in data input mode until another valid command is issued. Though data input mode is enabled, data input from the host is optional. Data input begins at the column address specified.

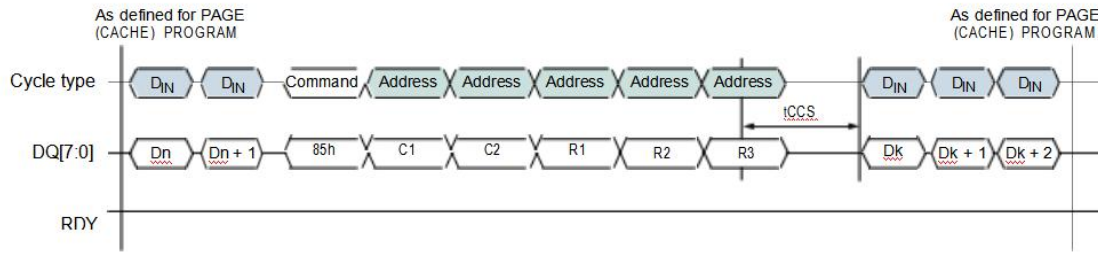
The CHANGE ROW ADDRESS (85h) command is allowed after the required address cycles are specified, but prior to the final command cycle (10h, 11h, 15h) of the following commands while data input is permitted: PROGRAM PAGE (80h-10h), PROGRAM PAGE MULTI-PLANE (80h-11h), PROGRAM PAGE CACHE (80h-15h), COPYBACK PROGRAM (85h-10h), and COPYBACK PROGRAM MULTI-PLANE (85h-11h). When used with these commands, the LUN address and plane select bits are required to be identical to the LUN address and plane select bits originally specified.

The CHANGE ROW ADDRESS (85h) command enables the host to modify the original page and block address for the data in the cache register to a new page and block address.

In devices that have more than one die (LUN) per target, the CHANGE ROW ADDRESS (85h) command can be used with other commands that support interleaved die (multi-LUN) operations.

The CHANGE ROW ADDRESS (85h) command can be used with the CHANGE READ COLUMN (05h-E0h) or CHANGE READ COLUMN ENHANCED (06h-E0h) commands to read and modify cache register contents in small sections prior to programming cache register contents to the NAND Flash array. This capability can reduce the amount of buffer memory used in the host controller.

To modify the cache register contents in small sections, first issue a PAGE READ (00h-30h) or COPYBACK READ (00h-35h) operation. When data output is enabled, the host can output a portion of the cache register contents. To modify the cache register contents, issue the 85h command, the column and row addresses, and input the new data. The host can re-enable data output by issuing the 11h command, waiting tDBSY, and then issuing the CHANGE READ COLUMN (05h-E0h) or CHANGE READ COLUMN ENHANCED (06h-E0h) command. It is possible to toggle between data output and data input multiple times. After the final CHANGE ROW ADDRESS (85h) operation is complete, issue the 10h command to program the cache register to the NAND Flash array.

Figure 42: CHANGE ROW ADDRESS (85h) Operation


20 Read Operations

Read operations are used to copy data from the NAND Flash array of one or more of the planes to their respective cache registers and to enable data output from the cache registers to the host through the DQ bus.

- Read Operations

The READ PAGE (00h-30h) command, when issued by itself, reads one page from the NAND Flash array to its cache register and enables data output for that cache register.

During data output the following commands can be used to read and modify the data in the cache registers: CHANGE READ COLUMN (05h-E0h) and CHANGE ROW ADDRESS (85h).

- Read Cache Operations

To increase data throughput, the READ PAGE CACHE-series (31h, 00h-31h) commands can be used to output data from the cache register while concurrently copying a page from the NAND Flash array to the data register.

To begin a read page cache sequence, begin by reading a page from the NAND Flash array to its corresponding cache register using the READ PAGE (00h-30h) command. R/B# goes LOW during t_R and the selected die (LUN) is busy (RDY = 0, ARDY = 0). After t_R (R/B# is HIGH and RDY = 1, ARDY = 1), issue either of these commands:

- READ PAGE CACHE SEQUENTIAL (31h)—copies the next sequential page from the NAND Flash array to the data register
- READ PAGE CACHE RANDOM (00h-31h)—copies the page specified in this command from the NAND Flash array (any plane) to its corresponding data register

After the READ PAGE CACHE-series (31h, 00h-31h) command has been issued, R/B# goes LOW on the target, and RDY = 0 and ARDY = 0 on the die (LUN) for t_{RCBSY} while the next page begins copying data from the array to the data register. After t_{RCBSY} ,

R/B# goes HIGH and the die's (LUN's) status register bits indicate the device is busy with a cache operation (RDY = 1, ARDY = 0). The cache register becomes available and the page requested in the READ PAGE CACHE operation is transferred to the data register. At this point, data can be output from the cache register, beginning at column address 0. The CHANGE READ COLUMN (05h-E0h) command can be used to change the column address of the data output by the die (LUN).



After outputting the desired number of bytes from the cache register, either an additional READ PAGE CACHE-series (31h, 00h-31h) operation can be started or the READ PAGE CACHE LAST (3Fh) command can be issued.

If the READ PAGE CACHE LAST (3Fh) command is issued, R/B# goes LOW on the target, and RDY = 0 and ARDY = 0 on the die (LUN) for tRCBSY while the data register is copied into the cache register. After tRCBSY, R/B# goes HIGH and RDY = 1 and ARDY = 1, indicating that the cache register is available and that the die (LUN) is ready. Data can then be output from the cache register, beginning at column address 0. The CHANGE READ COLUMN (05h-E0h) command can be used to change the column address of the data being output.

For READ PAGE CACHE-series (31h, 00h-31h, 3Fh), during the die (LUN) busy time, tRCBSY, when RDY = 0 and ARDY = 0, the only valid commands are status operations (70h, 78h) and RESET (FFh, FCh). When RDY = 1 and ARDY = 0, the only valid commands during READ PAGE CACHE-series (31h, 00h-31h) operations are status operations (70h, 78h), READ MODE (00h), READ PAGE CACHE-series (31h, 00h-31h), CHANGE READ COLUMN (05h-E0h), and RESET (FFh, FCh).

- Multi-Plane Read Operations

Multi-plane read page operations improve data throughput by copying data from more than one plane simultaneously to the specified cache registers. This is done by pre-pending one or more READ PAGE MULTI-PLANE (00h-32h) commands in front of the READ PAGE (00h-30h) command.

When the die (LUN) is ready, the CHANGE READ COLUMN ENHANCED (06h-E0h) command determines which plane outputs data. During data output, the following commands can be used to read and modify the data in the cache registers: CHANGE READ COLUMN (05h-E0h) and CHANGE ROW ADDRESS (85h). See Multi-Plane Operations for details.

- Multi-Plane Read Cache Operations

Multi-plane read cache operations can be used to output data from more than one cache register while concurrently copying one or more pages from the NAND Flash array to the data register. This is done by pre-pending READ PAGE MULTI-PLANE (00h-32h) commands in front of the PAGE READ CACHE RANDOM (00h-31h) command.

To begin a multi-plane read page cache sequence, begin by issuing a MULTI-PLANE READ PAGE operation using the READ PAGE MULTI-PLANE (00h-32h) and READ PAGE (00h-30h) commands. R/B# goes LOW during tR and the selected die (LUN) is busy (RDY = 0, ARDY = 0). After tR (R/B# is HIGH and RDY = 1, ARDY = 1), issue either of these commands:

- READ PAGE CACHE SEQUENTIAL (31h)—copies the next sequential page from the previously addressed planes from the NAND Flash array to the data registers.
- READ PAGE MULTI-PLANE (00h-32h) commands, if desired, followed by the READ PAGE CACHE RANDOM (00h-31h) command—copies the pages specified from the NAND Flash array to the corresponding data registers.



After the READ PAGE CACHE-series (31h, 00h-31h) command has been issued, R/B# goes LOW on the target, and RDY = 0 and ARDY = 0 on the die (LUN) for tRCBSY while the next pages begin copying data from the array to the data registers. After tRCBSY, R/B# goes HIGH and the LUN's status register bits indicate the device is busy with a cache operation (RDY = 1, ARDY = 0). The cache registers become available and the pages requested in the READ PAGE CACHE operation are transferred to the data registers. Issue the CHANGE READ COLUMN ENHANCED (06h-E0h) command to determine which cache register will output data. After data is output, the CHANGE READ COLUMN ENHANCED (06h-E0h) command can be used to output data from other cache registers. After a cache register has been selected, the CHANGE READ COLUMN (05h-E0h) command can be used to change the column address of the data output.

After outputting data from the cache registers, either an additional MULTI-PLANE READ CACHE-series (31h, 00h-31h) operation can be started or the READ PAGE CACHE LAST (3Fh) command can be issued.

If the READ PAGE CACHE LAST (3Fh) command is issued, R/B# goes LOW on the target, and RDY = 0 and ARDY = 0 on the die (LUN) for tRCBSY while the data registers are copied into the cache registers. After tRCBSY, R/B# goes HIGH and RDY = 1 and ARDY = 1, indicating that the cache registers are available and that the die (LUN) is ready. Issue the CHANGE READ COLUMN ENHANCED (06h-E0h) command to determine which cache register will output data. After data is output, the CHANGE READ COLUMN ENHANCED (06h-E0h) command can be used to output data from other cache registers. After a cache register has been selected, the CHANGE READ COLUMN (05h-E0h) command can be used to change the column address of the data output.

For READ PAGE CACHE-series (31h, 00h-31h, 3Fh), during the die (LUN) busy time, tRCBSY, when RDY = 0 and ARDY = 0, the only valid commands are status operations (70h, 78h) and RESET (FFh, FCh). When RDY = 1 and ARDY = 0, the only valid commands during READ PAGE CACHE-series (31h, 00h-31h) operations are status operations (70h, 78h), READ MODE (00h), multi-plane read cache-series (31h, 00h-32h, 00h-31h), CHANGE READ COLUMN (05h-E0h, 06h-E0h), and RESET (FFh, FCh).

See Multi-Plane Operations for additional multi-plane addressing requirements.

20.1 READ MODE (00h)

The READ MODE (00h) command disables status output and enables data output for the last-selected die (LUN) and cache register after a READ operation (00h-30h, 00h-35h) has been monitored with a status operation (70h, 78h). This command is accepted by the die (LUN) when it is ready (RDY = 1, ARDY = 1). It is also accepted by the die (LUN) during READ PAGE CACHE (31h, 3Fh, 00h-31h) operations (RDY = 1 and ARDY = 0).

In devices that have more than one die (LUN) per target, during and following interleaved die (multi-LUN) operations, the READ STATUS ENHANCED (78h) command must be used to select only one die (LUN) prior to issuing the READ MODE (00h) command. This prevents bus contention.

20.2 READ PAGE (00h-30h)

The READ PAGE (00h–30h) command copies a page from the NAND Flash array to its respective cache register and enables data output. This command is accepted by the die (LUN) when it is ready (RDY = 1, ARDY = 1).

To read a page from the NAND Flash array, write the 00h command to the command register, the write five address cycles to the address registers, and conclude with the 30h command. The selected die (LUN) will go busy (RDY = 0, ARDY = 0) for t_R as data is transferred.

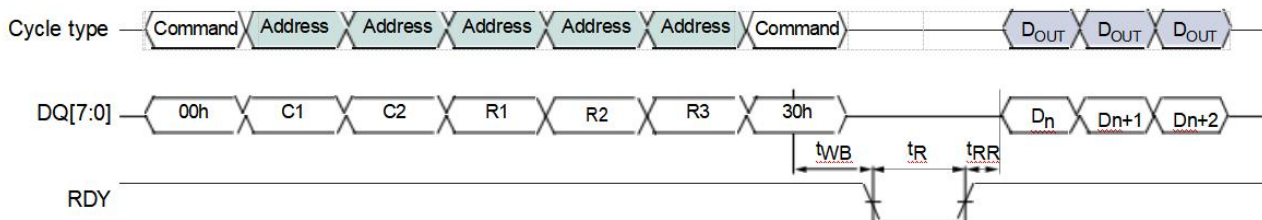
To determine the progress of the data transfer, the host can monitor the target's R/B# signal or, alternatively, the status operations (70h, 78h) can be used. If the status operations are used to monitor the LUN's status, when the die (LUN) is ready (RDY = 1, ARDY = 1), the host disables status output and enables data output by issuing the READ MODE (00h) command. When the host requests data output, output begins at the column address specified.

During data output the CHANGE READ COLUMN (05h-E0h) command can be issued.

In devices that have more than one die (LUN) per target, during and following interleaved die (multi-LUN) operations the READ STATUS ENHANCED (78h) command must be used to select only one die (LUN) prior to the issue of the READ MODE (00h) command. This prevents bus contention.

The READ PAGE (00h-30h) command is used as the final command of a multi-plane read operation. It is preceded by one or more READ PAGE MULTI-PLANE (00h-32h) commands. Data is transferred from the NAND Flash array for all of the addressed planes to their respective cache registers. When the die (LUN) is ready (RDY = 1, ARDY = 1), data output is enabled for the cache register linked to the plane addressed in the READ PAGE (00h-30h) command. When the host requests data output, output begins at the column address last specified in the READ PAGE (00h-30h) command. The CHANGE READ COLUMN ENHANCED (06h-E0h) command is used to enable data output in the other cache registers. See Multi-Plane Operations for additional multi-plane addressing requirements.

Figure 43: READ PAGE (00h-30h) Operation





20.4 READ PAGE CACHE RANDOM (00h-31h)

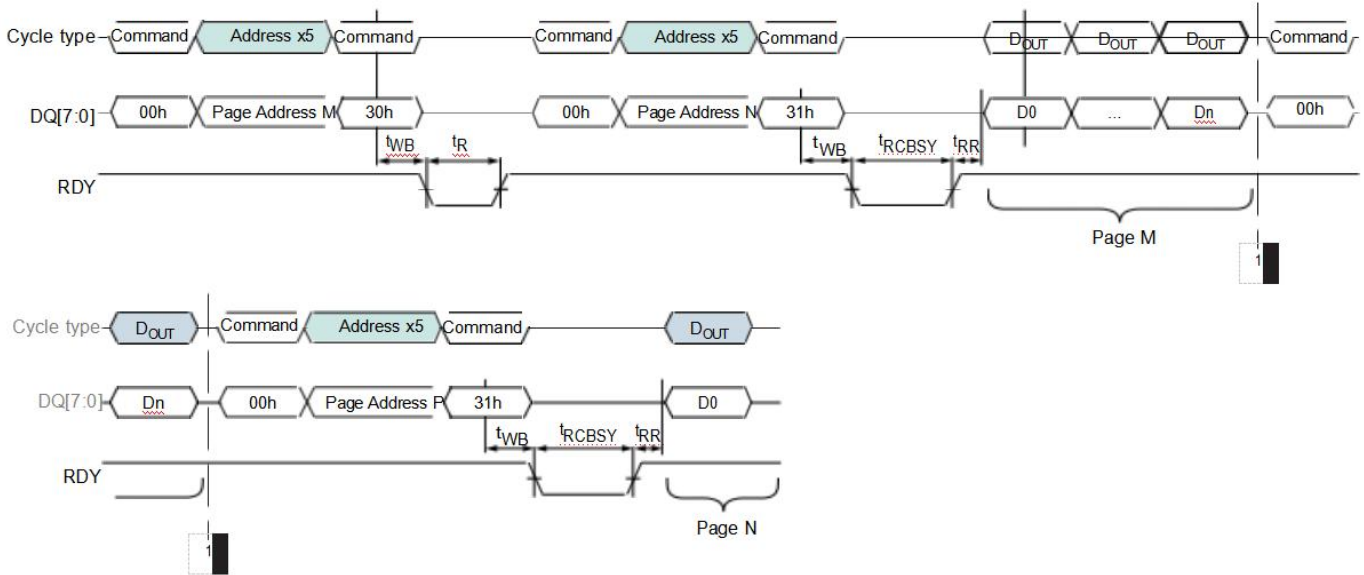
The READ PAGE CACHE RANDOM (00h-31h) command reads the specified block and page into the data register while the previous page is output from the cache register. This command is accepted by the die (LUN) when it is ready (RDY = 1, ARDY = 1). It is also accepted by the die (LUN) during READ PAGE CACHE (31h, 00h-31h) operations (RDY = 1 and ARDY = 0).

To issue this command, write 00h to the command register, then write five address cycles to the address register, and conclude by writing 31h to the command register. The column address in the address specified is ignored. The die (LUN) address must match the same die (LUN) address as the previous READ PAGE (00h-30h) command or, if applicable, the previous READ PAGE CACHE RANDOM (00h-31h) command. There is no restriction on the plane address.

After this command is issued, R/B# goes LOW and the die (LUN) is busy (RDY = 0, ARDY = 0) for tRCBSY. After tRCBSY, R/B# goes HIGH and the die (LUN) is busy with a cache operation (RDY = 1, ARDY = 0), indicating that the cache register is available and that the specified page is copying from the NAND Flash array to the data register. At this point, data can be output from the cache register beginning at column address 0. The CHANGE READ COLUMN (05h-E0h) command can be used to change the column address of the data being output from the cache register.

In devices that have more than one die (LUN) per target, during and following interleaved die (multi-LUN) operations the READ STATUS ENHANCED (78h) command followed by the READ MODE (00h) command must be used to select only one die (LUN) and prevent bus contention.

If a MULTI-PLANE CACHE RANDOM (00h-32h, 00h-31h) command is issued after a MULTI-PLANE READ PAGE operation (00h-32h, 00h-30h), then the addressed pages are read into the data registers while the previous pages can be output from the cache registers. After the die (LUN) is ready (RDY = 1, ARDY = 0), the CHANGE READ COLUMN ENHANCED (06h-E0h) command is used to select which cache register outputs data.

Figure 45: READ PAGE CACHE RANDOM (00h-31h) Operation


20.5 READ PAGE CACHE LAST (3Fh)

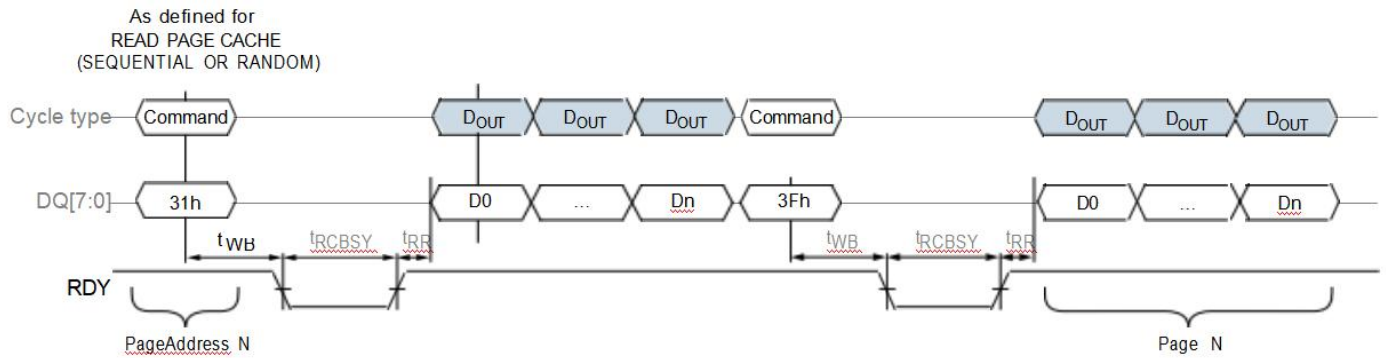
The READ PAGE CACHE LAST (3Fh) command ends the read page cache sequence and copies a page from the data register to the cache register. This command is accepted by the die (LUN) when it is ready (RDY = 1, ARDY = 1). It is also accepted by the die (LUN) during READ PAGE CACHE (31h, 00h-31h) operations (RDY = 1 and ARDY = 0).

To issue the READ PAGE CACHE LAST (3Fh) command, write 3Fh to the command register. After this command is issued, R/B# goes LOW and the die (LUN) is busy (RDY = 0, ARDY = 0) for tRCBSY. After tRCBSY, R/B# goes HIGH and the die (LUN) is ready (RDY = 1, ARDY = 1). At this point, data can be output from the cache register, beginning at column address 0. The CHANGE READ COLUMN (05h-E0h) command can be used to change the column address of the data being output from the cache register.

In devices that have more than one LUN per target, during and following interleaved die (multi-LUN) operations the READ STATUS ENHANCED (78h) command followed by the READ MODE (00h) command must be used to select only one die (LUN) and prevent bus contention.

If the READ PAGE CACHE LAST (3Fh) command is issued after a MULTI-PLANE READ PAGE CACHE operation (31h; 00h-32h, 00h-30h), the die (LUN) goes busy until the pages are copied from the data registers to the cache registers. After the die (LUN) is ready (RDY = 1, ARDY = 1), the CHANGE READ COLUMN ENHANCED (06h-E0h) command is used to select which cache register outputs data.

Figure 46: READ PAGE CACHE LAST (3Fh) Operation



MK FOUNFER CONFIDENTIAL



20.6 READ PAGE MULTI-PLANE (00h-32h)

The READ PAGE MULTI-PLANE (00h-32h) command queues a plane to transfer data from the NAND flash array to its cache register. This command can be issued one or more times. Each time a new plane address is specified, that plane is also queued for data transfer. The READ PAGE (00h-30h) command is issued to select the final plane and to begin the read operation for all previously queued planes. All queued planes will transfer data from the NAND Flash array to their cache registers.

To issue the READ PAGE MULTI-PLANE (00h-32h) command, write 00h to the command register, then write five address cycles to the address register, and conclude by writing 32h to the command register. The column address in the address specified is ignored.

After this command is issued, R/B# goes LOW and the die (LUN) is busy (RDY = 0, ARDY = 0) for tDBSY. After tDBSY, R/B# goes HIGH and the die (LUN) is ready (RDY = 1, ARDY = 1). At this point, the die (LUN) and block are queued for data transfer from the array to the cache register for the addressed plane. During tDBSY, the only valid commands are status operations (70h, 78h) and reset commands (FFh, FCh).

Following tDBSY, to continue the MULTI-PLANE READ operation, the only valid commands are status operations (70h, 78h), READ PAGE MULTI-PLANE (00h-32h), READ PAGE (00h-30h), and READ PAGE CACHE RANDOM (00h-31h).

Additional READ PAGE MULTI-PLANE (00h-32h) commands can be issued to queue additional planes for data transfer.

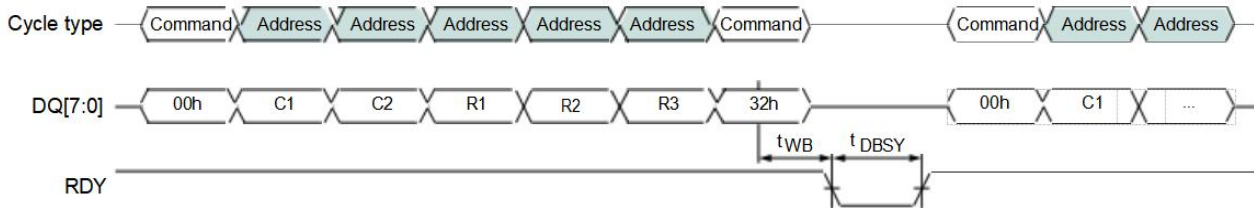
If the READ PAGE (00h-30h) command is used as the final command of a MULTI-PLANE READ operation, data is transferred from the NAND Flash array for all of the addressed planes to their respective cache registers. When the die (LUN) is ready (RDY = 1, ARDY = 1), data output is enabled for the cache register linked to the last even plane addressed. When the host requests data output, it begins at the column address specified in the READ PAGE (00h-30h) command. To enable data output in the other cache registers, use the CHANGE READ COLUMN ENHANCED (06h-E0h) command. Additionally, the CHANGE READ COLUMN (05h-E0h) command can be used to change the column address within the currently selected plane.

If the READ PAGE CACHE SEQUENTIAL (31h) is used as the final command of a MULTI-PLANE READ CACHE operation, data is copied from the previously read operation from each plane to each cache register and then data is transferred from the NAND Flash array for all previously addressed planes to their respective data registers. When the die (LUN) is ready (RDY = 1, ARDY = 0), data output is enabled. The CHANGE READ COLUMN ENHANCED (06h-E0h) command is used to determine which cache register outputs data first. To enable data output in the other cache registers, use the CHANGE READ COLUMN ENHANCED (06h-E0h) command. Additionally, the CHANGE READ COLUMN (05h-E0h) command can be used to change the column address within the currently selected plane.

If the READ PAGE CACHE RANDOM (00h-31h) command is used as the final command of a MULTI-PLANE READ CACHE operation, data is copied from the previously read operation from the data register to the cache register and then data is transferred from the NAND Flash array for all of the addressed planes to their respective data registers. When the die (LUN) is ready (RDY = 1, ARDY = 0), data output is enabled. The CHANGE READ COLUMN ENHANCED (06h-E0h) command is used to determine which cache register outputs data first. To enable data output in the other cache registers, use the CHANGE READ COLUMN

ENHANCED (06h-E0h) command. Additionally, the CHANGE READ COLUMN (05h-E0h) command can be used to change the column address within the currently selected plane. See Multi-Plane Operations for additional multi-plane addressing requirements.

Figure 47: READ PAGE MULTI-PLANE (00h-32h) Operation



21 Read Retry Operations

Read Retry Operations are used as an additional method to recover from bit errors beyond the ECC correction threshold.

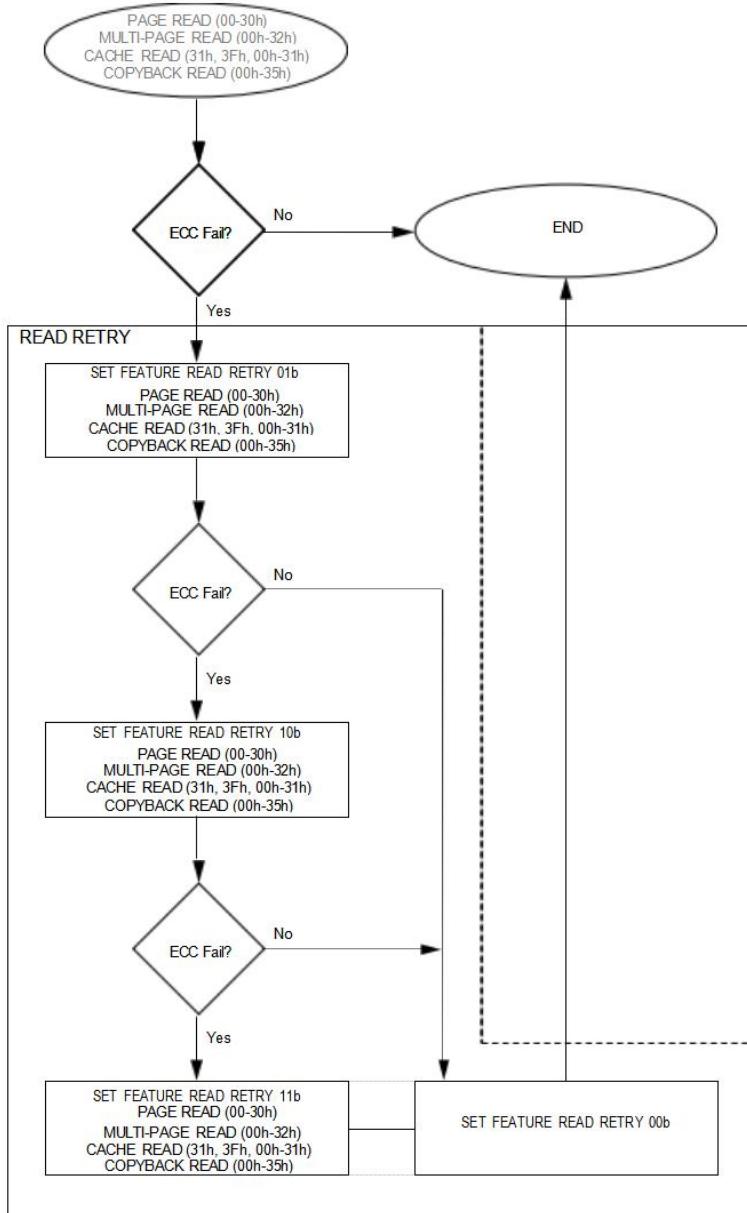
- Read Retry Operations

The Read Retry Operations are a coordination of Read Operations and Set Features (EFh) with Feature Address 89h selecting different internal read settings in attempt to recover data that is beyond the ECC correction threshold. Using the Read Retry Operations with any array Read Operation commands is allowed. See Configuration Operations and Feature Address 89h: Read Retry for details.

If reading a page has failed for bit errors beyond the ECC correction threshold, the host issues the SET FEATURE (EFh) command to feature address 89h with P1 subfeature set to a Read Retry option as defined in that feature address. A new NAND array Read Operation can now be performed. If the read still fails for bit errors beyond the ECC correction threshold, issue the SET FEATURES (EFh) command with the Read Retry (89h) feature address to select the next consecutive Read Retry option and repeat Read Retry Operations until the data is correctable or the last option has been attempted. If the reread is now correctable within the ECC threshold limits, the next Read Retry option should be set to its default value before the next NAND array Read Operation. See Figure 58 (page 91) for flow diagram of Read Retry Operations.

When the user writes to the Read Retry feature address then all subsequent reads use the internal NAND settings associated with that value until either the Read Retry feature address is rewritten or the device is powered down. This feature should not be used with the following commands: READ PARAMETER PAGE (ECh), READ UNIQUE ID (EDh), READ OTP PAGE (00h-30h).

Figure 48: Read Retry flow chart



Note: 1. There may be more Read Retry options than are shown in the figure for this NAND device. See Configuration Operations and Read Retry (89h) feature address for details.



22 Program Operations

Program operations are used to move data from the cache or data registers to the NAND array of one or more planes. During a program operation the contents of the cache and/or data registers are modified by the internal control logic.

Within a block, pages must be programmed sequentially from the least significant page address to the most significant page address (i.e. 0, 1, 2, 3, ...). Programming pages out of order within a block is prohibited.

- Program Operations

The PROGRAM PAGE (80h-10h) command, when not preceded by the PROGRAM PAGE MULTI-PLANE (80h-11h) command, programs one page from the cache register to the NAND Flash array. When the die (LUN) is ready (RDY = 1, ARDY = 1), the host should check the FAIL bit to verify that the operation has completed successfully.

- Program Cache Operations

The PROGRAM PAGE CACHE (80h-15h) command can be used to improve program operation system performance. When this command is issued, the die (LUN) goes busy (RDY = 0, ARDY = 0) while the cache register contents are copied to the data register, and the die (LUN) is busy with a program cache operation (RDY = 1, ARDY = 0). While the contents of the data register are moved to the NAND Flash array, the cache register is available for an additional PROGRAM PAGE CACHE (80h-15h) or PROGRAM PAGE (80h-10h) command.

For PROGRAM PAGE CACHE-series (80h-15h) operations, during the die (LUN) busy times, t_{CBSY} and t_{LPROG} , when RDY = 0 and ARDY = 0, the only valid commands are status operations (70h, 78h) and reset (FFh, FCh). When RDY = 1 and ARDY = 0, the only valid commands during PROGRAM PAGE CACHE series (80h-15h) operations are status operations (70h, 78h), PROGRAM PAGE CACHE (80h-15h), PROGRAM PAGE (80h-10h), CHANGE WRITE COLUMN (85h), CHANGE ROW ADDRESS (85h), and reset (FFh, FCh).

- Multi-Plane Program Operations

The PROGRAM PAGE MULTI-PLANE (80h-11h) command can be used to improve program operation system performance by enabling multiple pages to be moved from the cache registers to different planes of the NAND Flash array. This is done by prepending one or more PROGRAM PAGE MULTI-PLANE (80h-11h) commands in front of the PROGRAM PAGE (80h-10h) command. See Multi-Plane Operations for details.

- Multi-Plane Program Cache Operations

The PROGRAM PAGE MULTI-PLANE (80h-11h) command can be used to improve program cache operation system performance by enabling multiple pages to be moved from the cache registers to the data registers and, while the pages are being transferred from the data registers to different planes of the NAND Flash array, free the cache registers to receive data input from the host. This is done by prepending one or more PROGRAM PAGE MULTI-PLANE (80h-11h) commands in front of the PROGRAM PAGE CACHE (80h-15h) command. See Multi-Plane Operations for details.

22.1 PROGRAM PAGE (80h-10h)

The PROGRAM PAGE (80h-10h) command enables the host to input data to a cache register, and moves the data from the cache register to the specified block and page address in the array of the selected die (LUN). This command is accepted by the die (LUN) when it is ready (RDY = 1, ARDY = 1). It is also accepted by the die (LUN) when it is busy with a PROGRAM PAGE CACHE (80h-15h) operation (RDY = 1, ARDY = 0).

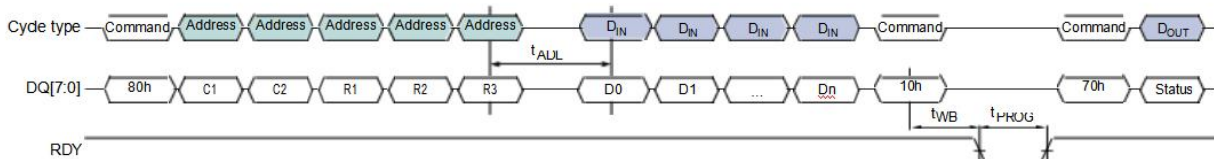
To input a page to the cache register and move it to the NAND array at the block and page address specified, write 80h to the command register. Unless this command has been preceded by a PROGRAM PAGE MULTI-PLANE (80h-11h) command, issuing the 80h to the command register clears all of the cache registers' contents on the selected target. Then write five address cycles containing the column address and row address. Data input cycles follow. Serial data is input beginning at the column address specified. At any time during the data input cycle the CHANGE WRITE COLUMN (85h) and CHANGE ROW ADDRESS (85h) commands may be issued. When data input is complete, write 10h to the command register. The selected LUN will go busy (RDY = 0, ARDY = 0) for t_{PROG} as data is transferred.

To determine the progress of the data transfer, the host can monitor the target's R/B# signal or, alternatively, the status operations (70h, 78h) may be used. When the die (LUN) is ready (RDY = 1, ARDY = 1), the host should check the status of the FAIL bit.

In devices that have more than one die (LUN) per target, during and following interleaved die (multi-LUN) operations, the READ STATUS ENHANCED (78h) command must be used to select only one die (LUN) for status output. Use of the READ STATUS (70h) command could cause more than one die (LUN) to respond, resulting in bus contention.

The PROGRAM PAGE (80h-10h) command is used as the final command of a multi-plane program operation. It is preceded by one or more PROGRAM PAGE MULTI- PLANE (80h-11h) commands. Data is transferred from the cache registers for all of the addressed planes to the NAND array. The host should check the status of the operation by using the status operations (70h, 78h). See Multi-Plane Operations for multi-plane addressing requirements.

Figure 49: PROGRAM PAGE (80h-10h) Operation





22.2 PROGRAM PAGE CACHE (80h-15h)

The PROGRAM PAGE CACHE (80h-15h) command enables the host to input data to a cache register; copies the data from the cache register to the data register; then moves the data register contents to the specified block and page address in the array of the selected die (LUN). After the data is copied to the data register, the cache register is available for additional PROGRAM PAGE CACHE (80h-15h) or PROGRAM PAGE (80h-10h) commands. The PROGRAM PAGE CACHE (80h-15h) command is accepted by the die (LUN) when it is ready (RDY = 1, ARDY = 1). It is also accepted by the die (LUN) when busy with a PROGRAM PAGE CACHE (80h-15h) operation (RDY = 1, ARDY = 0).

To input a page to the cache register to move it to the NAND array at the block and page address specified, write 80h to the command register. Unless this command has been preceded by a PROGRAM PAGE MULTI-PLANE (80h-11h) command, issuing the 80h to the command register clears all of the cache registers' contents on the selected target. Then write five address cycles containing the column address and row address. Data input cycles follow. Serial data is input beginning at the column address specified. At any time during the data input cycle the CHANGE WRITE COLUMN (85h) and CHANGE ROW ADDRESS (85h) commands may be issued. When data input is complete, write 15h to the command register. The selected LUN will go busy (RDY = 0, ARDY = 0) for tCBSY to allow the data register to become available from a previous program cache operation, to copy data from the cache register to the data register, and then to begin moving the data register contents to the specified page and block address.

To determine the progress of tCBSY, the host can monitor the target's R/B# signal or, alternatively, the status operations (70h, 78h) can be used. When the LUN's status shows that it is busy with a PROGRAM CACHE operation (RDY = 1, ARDY = 0), the host should check the status of the FAILC bit to see if a previous cache operation was successful.

If, after tCBSY, the host wants to wait for the program cache operation to complete, without issuing the PROGRAM PAGE (80h-10h) command, the host should monitor ARDY until it is 1. The host should then check the status of the FAIL and FAILC bits.

In devices with more than one die (LUN) per target, during and following interleaved die (multi-LUN) operations, the READ STATUS ENHANCED (78h) command must be used to select only one die (LUN) for status output. Use of the READ STATUS (70h) command could cause more than one die (LUN) to respond, resulting in bus contention.

The PROGRAM PAGE CACHE (80h-15h) command is used as the final command of a multi-plane program cache operation. It is preceded by one or more PROGRAM PAGE MULTI-PLANE (80h-11h) commands. Data for all of the addressed planes is transferred from the cache registers to the corresponding data registers, then moved to the NAND Flash array. The host should check the status of the operation by using the status operations (70h, 78h). See Multi-Plane Operations for multi-plane addressing requirements.



Figure 50: PROGRAM PAGE CACHE (80h–15h) Operation (Start)

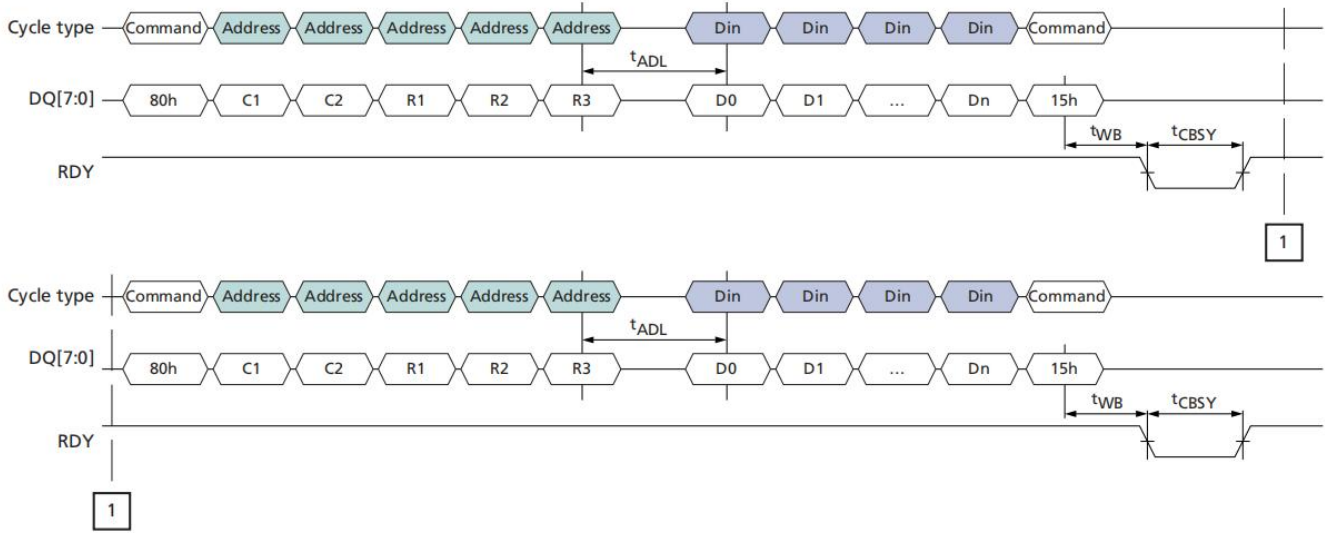
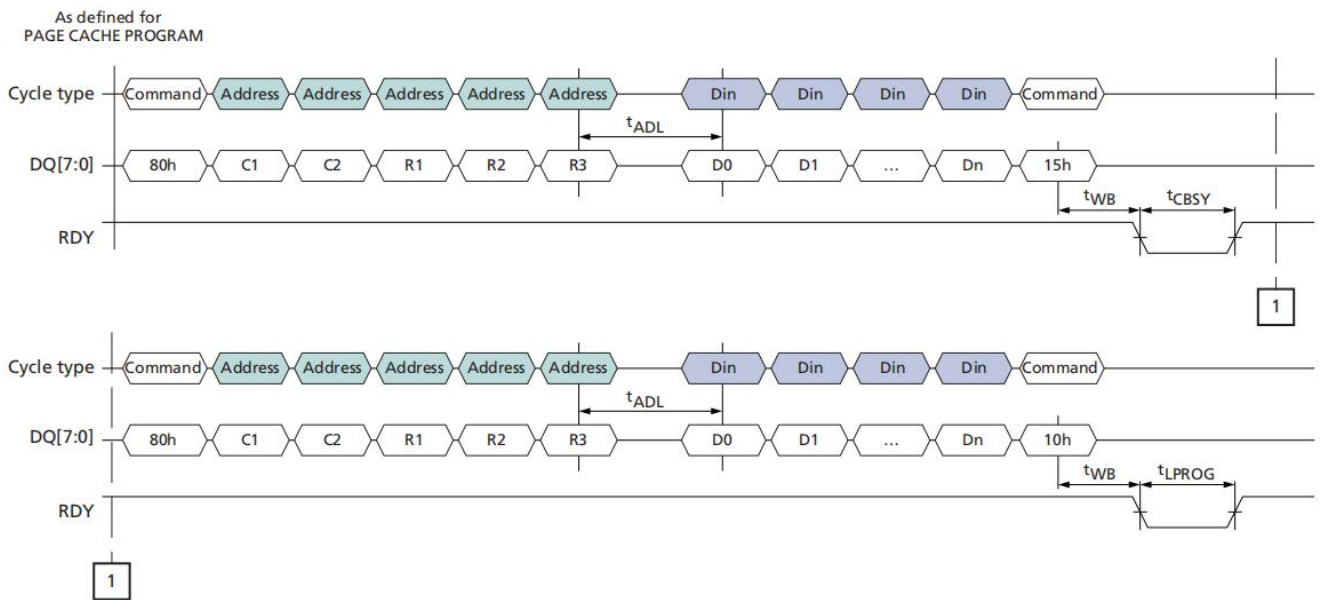


Figure 51: PROGRAM PAGE CACHE (80h–15h) Operation (End)





22.3 PROGRAM PAGE MULTI-PLANE (80h-11h)

The PROGRAM PAGE MULTI-PLANE (80h-11h) command enables the host to input data to the addressed plane's cache register and queue the cache register to ultimately be moved to the NAND Flash array. This command can be issued one or more times. Each time a new plane address is specified that plane is also queued for data transfer. To input data for the final plane and to begin the program operation for all previously queued planes, issue either the PROGRAM PAGE (80h-10h) command or the PROGRAM PAGE CACHE (80h-15h) command. All of the queued planes will move the data to the NAND Flash array. This command is accepted by the die (LUN) when it is ready (RDY = 1).

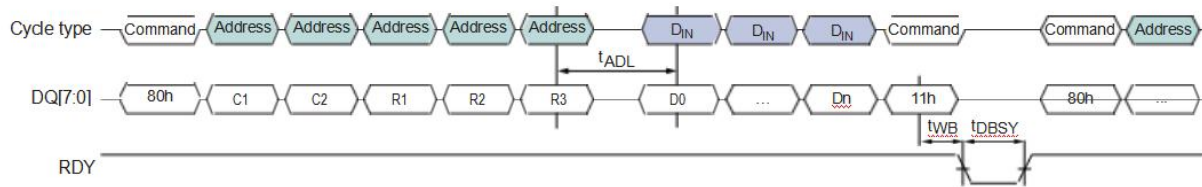
To input a page to the cache register and queue it to be moved to the NAND Flash array at the block and page address specified, write 80h to the command register. Unless this command has been preceded by an 11h command, issuing the 80h to the command register clears all of the cache registers' contents on the selected target. Write five address cycles containing the column address and row address; data input cycles follow. Serial data is input beginning at the column address specified. At any time during the data input cycle, the CHANGE WRITE COLUMN (85h) and CHANGE ROW ADDRESS (85h) commands can be issued. When data input is complete, write 11h to the command register. The selected die (LUN) will go busy (RDY = 0, ARDY = 0) for tDBSY.

To determine the progress of tDBSY, the host can monitor the target's R/B# signal or, alternatively, the status operations (70h, 78h) can be used. When the LUN's status shows that it is ready (RDY = 1), additional PROGRAM PAGE MULTI-PLANE (80h-11h) commands can be issued to queue additional planes for data transfer. Alternatively, the PROGRAM PAGE (80h-10h) or PROGRAM PAGE CACHE (80h-15h) commands can be issued.

When the PROGRAM PAGE (80h-10h) command is used as the final command of a multi-plane program operation, data is transferred from the cache registers to the NAND Flash array for all of the addressed planes during tPROG. When the die (LUN) is ready (RDY = 1, ARDY = 1), the host should check the status of the FAIL bit for each of the planes to verify that programming completed successfully.

When the PROGRAM PAGE CACHE (80h-15h) command is used as the final command of a MULTI-PLANE PROGRAM CACHE operation, data is transferred from the cache registers to the data registers after the previous array operations finish. The data is then moved from the data registers to the NAND Flash array for all of the addressed planes. This occurs during tCBSY. After tCBSY, the host should check the status of the FAILC bit for each of the planes from the previous program cache operation, if any, to verify that programming completed successfully.

For the PROGRAM PAGE MULTI-PLANE (80h-11h), PROGRAM PAGE (80h-10h), and PROGRAM PAGE CACHE (80h-15h) commands, see Multi-Plane Operations for multi-plane addressing requirements.

Figure 52: PROGRAM PAGE MULTI-PLANE (80h–11h) Operation


For JEDEC compliance the PROGRAM PAGE MULTI-PLANE (81h-11h) command is also supported. This would also include the last command 81h-10h to conclude a PROGRAM PAGE MULTI-PLANE sequence and 81h-15h to conclude a PROGRAM PAGE CACHE MULTI-PLANE sequence.

23 Erase Operations

Erase operations are used to clear the contents of a block in the NAND Flash array to prepare its pages for program operations.

- Erase Operations

The ERASE BLOCK (60h-D0h) command, when not preceded by the ERASE BLOCK MULTI-PLANE (60h-D1h) command, erases one block in the NAND Flash array. When the die (LUN) is ready (RDY = 1, ARDY = 1), the host should check the FAIL bit to verify that this operation completed successfully.

- MULTI-PLANE ERASE Operations

The ERASE BLOCK MULTI-PLANE (60h-D1h) command can be used to further system performance of erase operations by allowing more than one block to be erased in the NAND array. This is done by prepending one or more ERASE BLOCK MULTI-PLANE (60h-D1h) commands in front of the ERASE BLOCK (60h-D0h) command. See Multi-Plane Operations for details.

23.1 ERASE BLOCK (60h-D0h)

The ERASE BLOCK (60h-D0h) command erases the specified block in the NAND Flash array. This command is accepted by the die (LUN) when it is ready (RDY = 1, ARDY = 1).

To erase a block, write 60h to the command register. Then write three address cycles containing the row address; the page address is ignored. Conclude by writing D0h to the command register. The selected die (LUN) will go busy (RDY = 0, ARDY = 0) for tBERS while the block is erased.

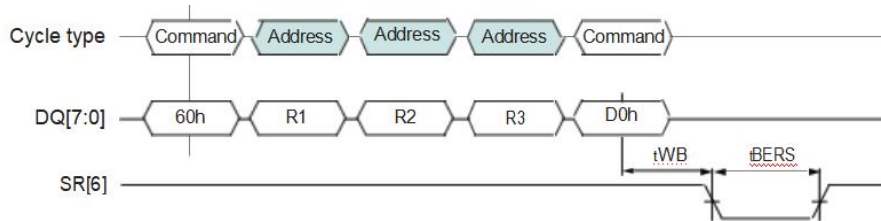
To determine the progress of an ERASE operation, the host can monitor the target's R/ B# signal, or alternatively, the status operations (70h, 78h) can be used. When the die (LUN) is ready (RDY = 1, ARDY = 1) the host should check the status of the FAIL bit.

In devices that have more than one die (LUN) per target, during and following interleaved die (multi-LUN) operations, the READ STATUS ENHANCED (78h) command must be used to select only one die (LUN) for

status output. Use of the READ STATUS (70h) command could cause more than one die (LUN) to respond, resulting in bus contention.

The ERASE BLOCK (60h-D0h) command is used as the final command of a MULTIPLANE ERASE operation. It is preceded by one or more ERASE BLOCK MULTI-PLANE (60h-D1h) commands. All of blocks in the addressed planes are erased. The host should check the status of the operation by using the status operations (70h, 78h). See Multi-Plane Operations for multi-plane addressing requirements.

Figure 53: ERASE BLOCK (60h-D0h) Operation



23.2 ERASE BLOCK MULTI-PLANE (60h-D1h)

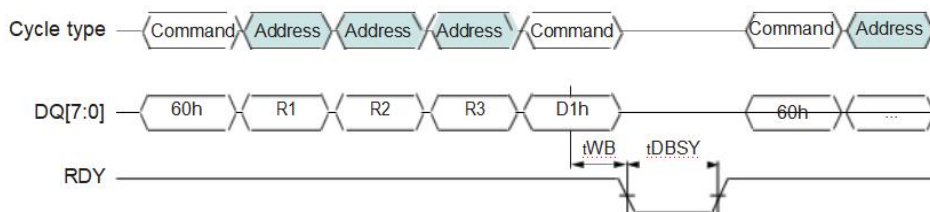
The ERASE BLOCK MULTI-PLANE (60h-D1h) command queues a block in the specified plane to be erased in the NAND Flash array. This command can be issued one or more times. Each time a new plane address is specified, that plane is also queued for a block to be erased. To specify the final block to be erased and to begin the ERASE operation for all previously queued planes, issue the ERASE BLOCK (60h-D0h) command. This command is accepted by the die (LUN) when it is ready (RDY = 1, ARDY = 1).

To queue a block to be erased, write 60h to the command register, then write three address cycles containing the row address; the page address is ignored. Conclude by writing D1h to the command register. The selected die (LUN) will go busy (RDY = 0, ARDY = 0) for tDBSY.

To determine the progress of tDBSY, the host can monitor the target's R/B# signal, or alternatively, the status operations (70h, 78h) can be used. When the LUN's status shows that it is ready (RDY = 1, ARDY = 1), additional ERASE BLOCK MULTI-PLANE (60h-D1h) commands can be issued to queue additional planes for erase. Alternatively, the ERASE BLOCK (60h-D0h) command can be issued to erase all of the queued blocks.

For multi-plane addressing requirements for the ERASE BLOCK MULTI-PLANE (60h-D1h) and ERASE BLOCK (60h-D0h) commands, see Multi-Plane Operations.

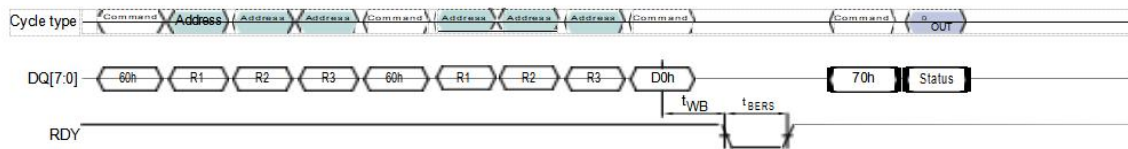
Figure 54: ERASE BLOCK MULTI-PLANE (60h-D1h) Operation



23.3 ERASE BLOCK MULTI-PLANE (60h-60h-D0h)

This operation behaves the same as the ERASE BLOCK MULTI-PLANE (60h-D1h) command followed by a ERASE BLOCK (60h-D0h) command.

Figure 55: ERASE BLOCK MULTI-PLANE (60h-60h-D0h) Operation



24 Copyback Operations

COPYBACK operations make it possible to transfer data within a plane from one page to another using the cache register. This is particularly useful for block management and wear leveling.

The COPYBACK operation is a two-step process consisting of a COPYBACK READ (00h-35h) and a COPYBACK PROGRAM (85h-10h) command. To move data from one page to another on the same plane, first issue the COPYBACK READ (00h-35h) command. When the die (LUN) is ready (RDY = 1, ARDY = 1), the host can transfer the data to a new page by issuing the COPYBACK PROGRAM (85h-10h) command. When the die (LUN) is again ready (RDY = 1, ARDY = 1), the host should check the FAIL bit to verify that this operation completed successfully.

To prevent bit errors from accumulating over multiple COPYBACK operations, it is recommended that the host read the data out of the cache register after the COPYBACK READ (00h-35h) completes prior to issuing the COPYBACK PROGRAM (85h-10h) command. The CHANGE READ COLUMN (05h-E0h) command can be used to change the column address. The host should check the data for ECC errors and correct them. When the COPYBACK PROGRAM (85h-10h) command is issued, any corrected data can be input. The CHANGE ROW ADDRESS (85h) command can be used to change the column address.

It is not possible to use the COPYBACK operation to move data from one plane to another or from one die (LUN) to another. Instead, use a READ PAGE (00h-30h) or COPYBACK READ (00h-35h) command to read the data out of the NAND, and then use a PROGRAM PAGE (80h-10h) command with data input to program the data to a new plane or die (LUN).

Between the COPYBACK READ (00h-35h) and COPYBACK PROGRAM (85h-10h) commands, the following commands are supported: status operations (70h, 78h), and column address operations (05h-E0h, 06h-E0h,

85h). Reset operations (FFh, FCh) can be issued after COPYBACK READ (00h-35h), but the contents of the cache registers on the target are not valid.

In devices which have more than one die (LUN) per target, once the COPYBACK READ (00h-35h) is issued, interleaved die (multi-LUN) operations are prohibited until after the COPYBACK PROGRAM (85h-10h) command is issued.

- Multi-Plane Copyback Operations

Multi-plane copy back read operations improve read data throughput by copying data simultaneously from more than one plane to the specified cache registers. This is done by prepending one or more READ PAGE MULTI-PLANE (00h-32h) commands in front of the COPYBACK READ (00h-35h) command.

The COPYBACK PROGRAM MULTI-PLANE (85h-11h) command can be used to further system performance of COPYBACK PROGRAM operations by enabling movement of multiple pages from the cache registers to different planes of the NAND Flash array. This is done by prepending one or more COPYBACK PROGRAM (85h-11h) commands in front of the COPYBACK PROGRAM (85h-10h) command. See Multi-Plane Operations for details.

24.1 COPYBACK READ (00h-35h)

The COPYBACK READ (00h-35h) command is functionally identical to the READ PAGE (00h-30h) command, except that 35h is written to the command register instead of 30h. See READ PAGE (00h-30h) (page 83) for further details.

Though it is not required, it is recommended that the host read the data out of the device to verify the data prior to issuing the COPYBACK PROGRAM (85h-10h) command to prevent the propagation of data errors.

Figure 56: COPYBACK READ (00h-35h) Operation

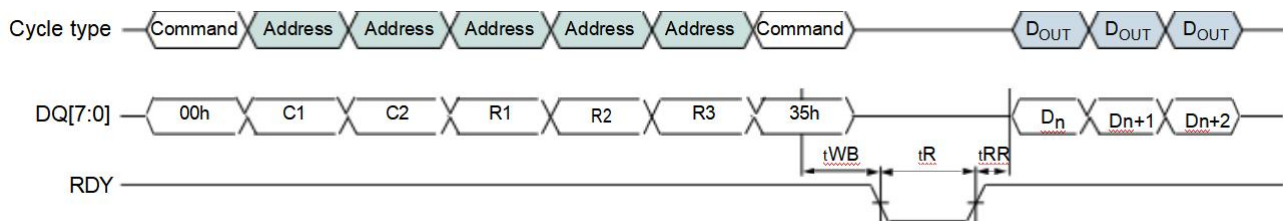
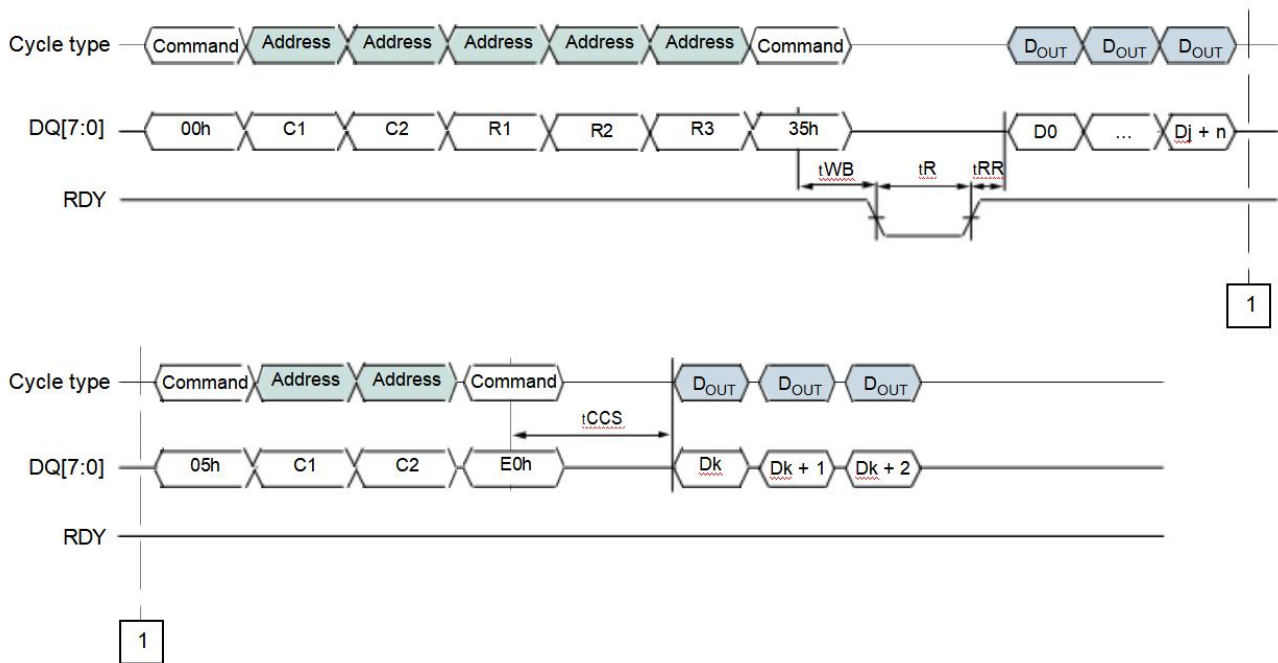


Figure 57: COPYBACK READ (00h–35h) with CHANGE READ COLUMN (05h–E0h) Operation


24.2 COPYBACK PROGRAM (85h–10h)

The COPYBACK PROGRAM (85h-10h) command is functionally identical to the PROGRAM PAGE (80h-10h) command, except that when 85h is written to the command register, cache register contents are not cleared. See PROGRAM PAGE (80h-10h) for further details.

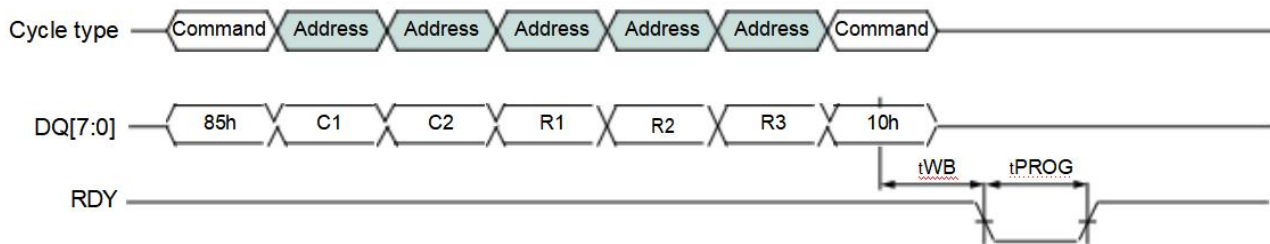
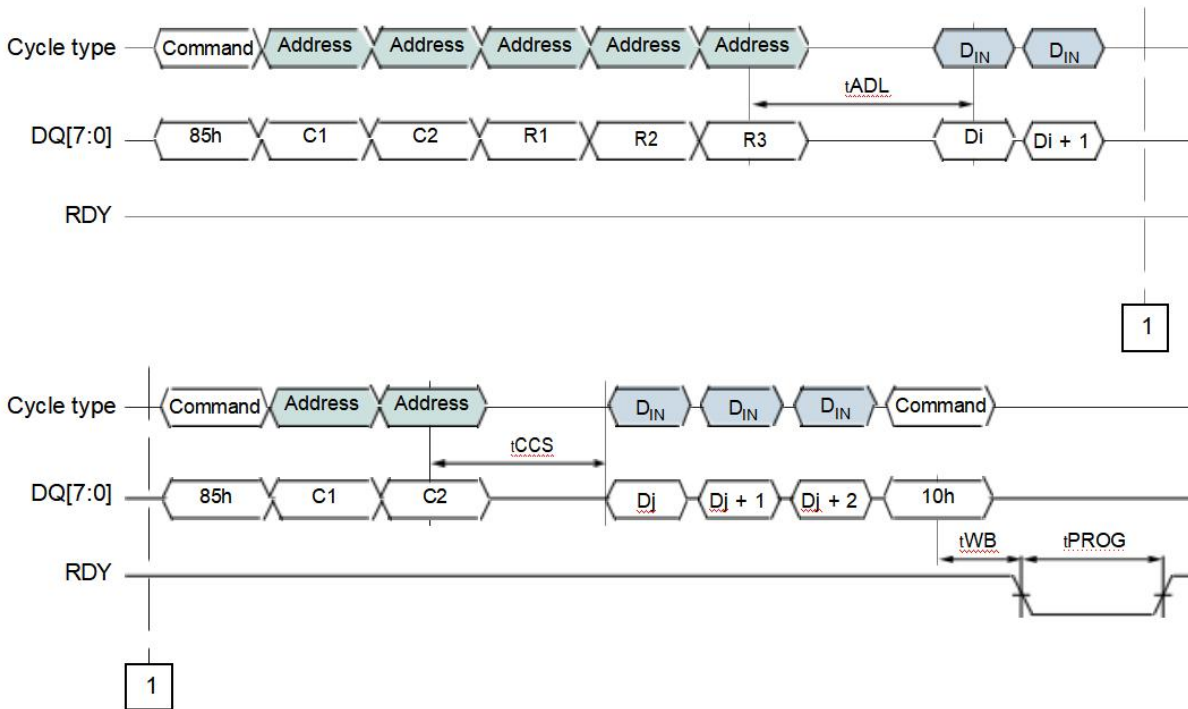
Figure 58: COPYBACK PROGRAM (85h–10h) Operation


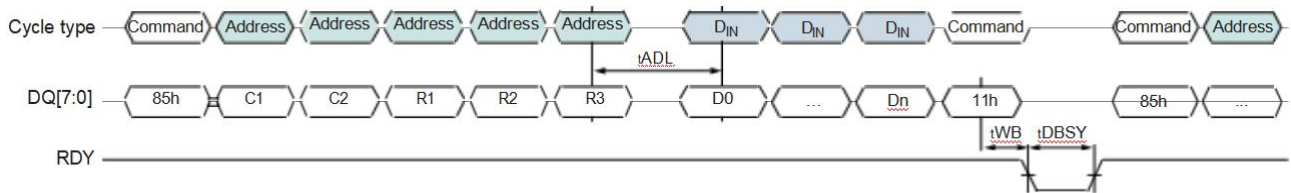
Figure 59: COPYBACK PROGRAM (85h-10h) with CHANGE WRITE COLUMN (85h) Operation


24.3 COPYBACK READ MULTI-PLANE (00h-32h)

The COPYBACK READ MULTI-PLANE (00h-32h) command is functionally identical to the READ PAGE MULTI-PLANE (00h-32h) command, except that the 35h command is written as the final command. The complete command sequence for the COPYBACK READ PAGE MULTI-PLANE is 00h-32h-00h-35h. See READ PAGE MULTI-PLANE (00h-32h) (page 88) for further details.

24.4 COPYBACK PROGRAM MULTI-PLANE (85h-11h)

The COPYBACK PROGRAM MULTI-PLANE (85h-11h) command is functionally identical to the PROGRAM PAGE MULTI-PLANE (80h-11h) command, except that when 85h is written to the command register, cache register contents are not cleared. See PROGRAM PAGE MULTI-PLANE (80h-11h) for further details.

Figure 60: COPYBACK PROGRAM MULTI-PLANE (85h-11h) Operation


25 One-Time Programmable (OTP) Operations

This Micron NAND Flash device offers a protected, one-time programmable NAND Flash memory area. Each target has an OTP area with a range of OTP pages (see Table 18 (page 105)); the entire range is guaranteed to be good. Customers can use the OTP area in any way they desire; typical uses include programming serial numbers or other data for permanent storage.

The OTP area leaves the factory in an erased state (all bits are 1). Programming an OTP page changes bits that are 1 to 0, but cannot change bits that are 0 to 1. The OTP area cannot be erased, even if it is not protected. Protecting the OTP area prevents further programming of the pages in the OTP area.

- **Enabling the OTP Operation Mode**

The OTP area is accessible while the OTP operation mode is enabled. To enable OTP operation mode, issue the SET FEATURES (EFh) command to feature address 90h and write 01h to P1, followed by three cycles of 00h to P2 through P4.

When the target is in OTP operation mode, all subsequent PAGE READ (00h-30h) and PROGRAM PAGE (80h-10h) commands are applied to the OTP area.

ERASE commands are not valid while the target is in OTP operation mode.

- **Programming OTP Pages**

Each page in the OTP area is programmed using the PROGRAM OTP PAGE (80h-10h) command. Each page can be programmed more than once, in sections, up to the maximum number allowed (see NOP in Table 18 (page 105)). The pages in the OTP area must be programmed in ascending order.

If the host issues a PAGE PROGRAM (80h-10h) command to an address beyond the maximum page-address range, the target will be busy for tOBSY and the WP# status register bit will be 0, meaning that the page is write-protected.

- **Protecting the OTP Area**

To protect the OTP area, issue the OTP PROTECT (80h-10h) command to the OTP Protect Page. When the OTP area is protected it cannot be programmed further. It is not possible to unprotect the OTP area after it has been protected.

- **Reading OTP Pages**

To read pages in the OTP area, whether the OTP area is protected or not, issue the PAGE READ (00h-30h) command.



If the host issues the PAGE READ (00h-30h) command to an address beyond the maximum page-address range, the data output will not be valid. To determine whether the target is busy during an OTP operation, either monitor R/B# or use the READ STATUS (70h) command. Use of the READ STATUS ENHANCED (78h) command is prohibited while the OTP operation is in progress.

● Returning to Normal Array Operation Mode

To exit OTP operation mode and return to normal array operation mode, issue the SET FEATURES (EFh) command to feature address 90h and write 00h to P1 through P4.

If the RESET (FFh) command is issued while in OTP operation mode, the target will exit OTP operation mode and enter normal operating mode. If the synchronous interface is active, the target will exit OTP operation and enable the asynchronous interface.

Table 18: OTP Area Details

Description	Value
Number of OTP pages	30
OTP protect page address	01h
OTP start page address	02h
Number of partial page programs (NOP) to each OTP page	4

25.1 PROGRAM OTP PAGE (80h-10h)

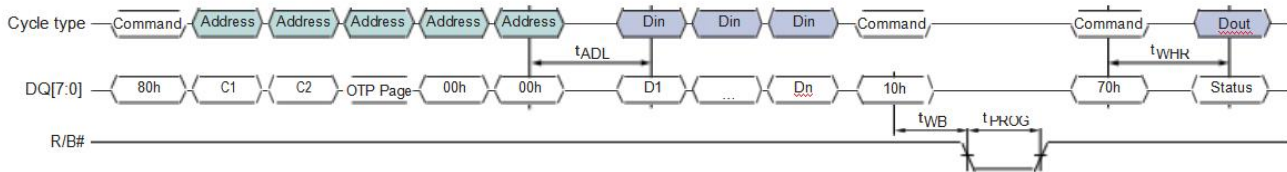
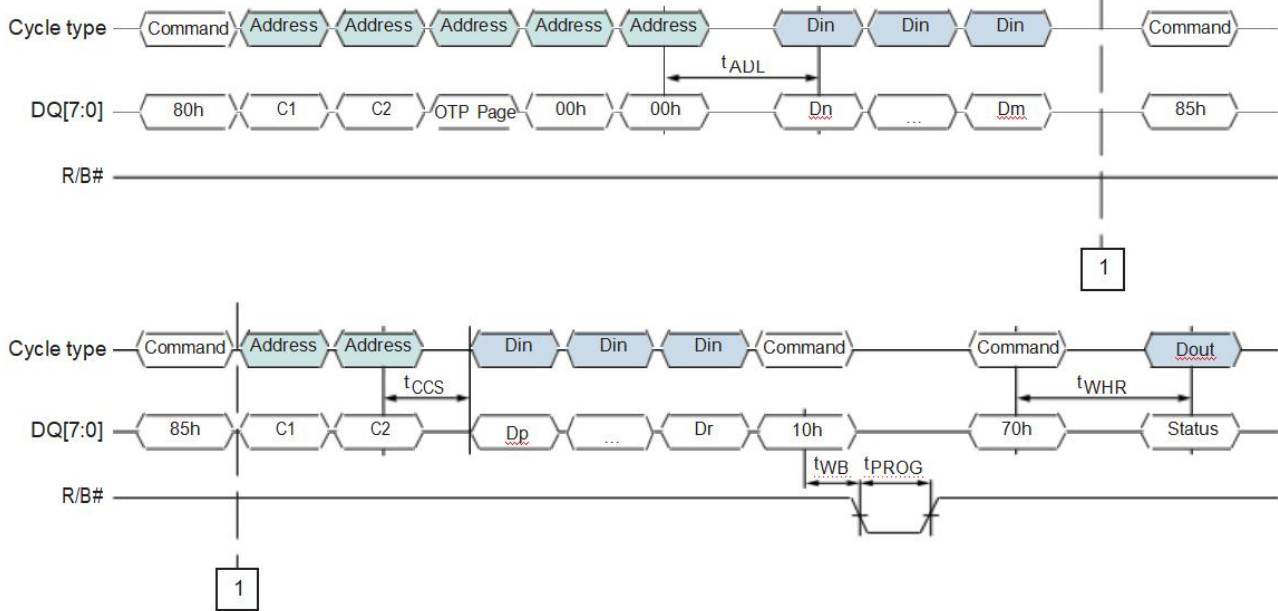
The PROGRAM OTP PAGE (80h-10h) command is used to write data to the pages within the OTP area. To program data in the OTP area, the target must be in OTP operation mode.

To use the PROGRAM OTP PAGE (80h-10h) command, issue the 80h command. Issue five address cycles including the column address, the page address within the OTP page range, and a block address of 0. Next, write the data to the cache register using data input cycles. After data input is complete, issue the 10h command.

R/B# goes LOW for the duration of the array programming time, tPROG. The READ STATUS (70h) command is the only valid command for reading status in OTP operation mode. The RDY bit of the status register will reflect the state of R/B#. Use of the READ STATUS ENHANCED (78h) command is prohibited. When the target is ready, read the FAIL bit of the status register to determine whether the operation passed or failed (see Status Operations).

The PROGRAM OTP PAGE (80h-10h) command also accepts the CHANGE WRITE COLUMN (85h) command during data input.

If a PROGRAM PAGE command is issued to the OTP area after the area has been protected, then R/B# goes LOW for tOBSY. After tOBSY, the status register is set to 60h.

Figure 61: PROGRAM OTP PAGE (80h-10h) Operation

Figure 62: PROGRAM OTP PAGE (80h-10h) with CHANGE WRITE COLUMN (85h) Operation


25.2 PROTECT OTP AREA (80h-10h)

The PROTECT OTP AREA (80h-10h) command is used to prevent further programming of the pages in the OTP area. To protect the OTP area, the target must be in OTP operation mode.

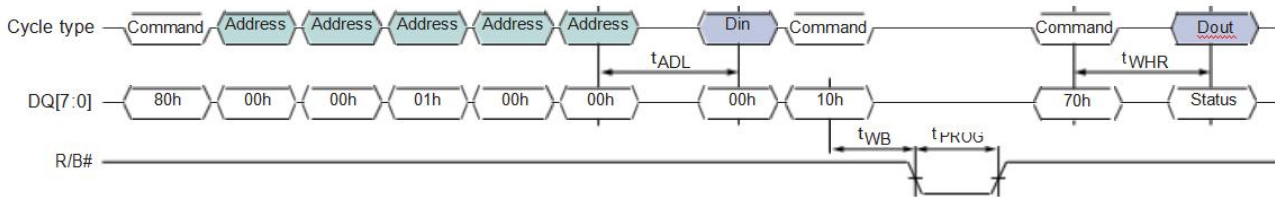
To protect all data in the OTP area, issue the 80h command. Issue five address cycles including the column address, OTP protect page address and block address; the column and block addresses are fixed to 0. Next, write 00h data for the first byte location and issue the 10h command.

R/B# goes LOW for the duration of the array programming time, t_{PROG} . The READ STATUS (70h) command is the only valid command for reading status in OTP operation mode. The RDY bit of the status register will reflect the state of R/B#. Use of the READ STATUS ENHANCED (78h) command is prohibited.

When the target is ready, read the FAIL bit of the status register to determine if the operation passed or failed (see Status Operations).

If the PROTECT OTP AREA (80h-10h) command is issued after the OTP area has already been protected, R/B# goes LOW for tOBSY. After tOBSY, the status register is set to 60h.

Figure 63: PROTECT OTP AREA (80h-10h) Operation



Note: 1. OTP data is protected following a status confirmation.

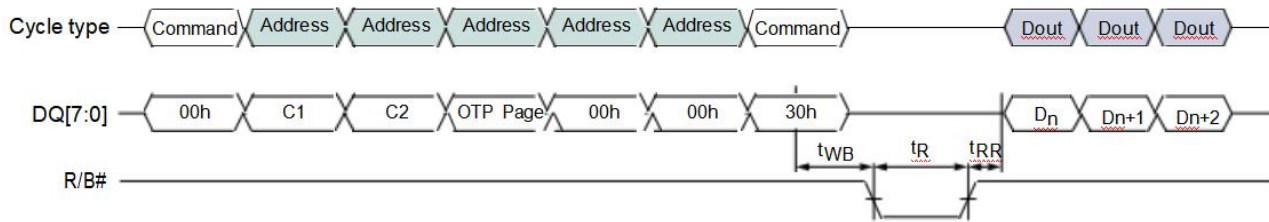
25.3 READ OTP PAGE (00h-30h)

The READ OTP PAGE (00h-30h) command is used to read data from the pages in the OTP area. To read data in the OTP area, the target must be in OTP operation mode.

To use the READ OTP PAGE (00h-30h) command, issue the 00h command. Issue five address cycles including the column address, the page address within the OTP page range, and a block address of 0. Next, issue the 30h command. The selected die (LUN) will go busy (RDY = 0, ARDY = 0) for tR as data is transferred.

To determine the progress of the data transfer, the host can monitor the target's R/B# signal, or alternatively the READ STATUS (70h) command can be used. If the status operations are used to monitor the die's (LUN's) status, when the die (LUN) is ready (RDY = 1, ARDY = 1) the host disables status output and enables data output by issuing the READ MODE (00h) command. When the host requests data output, it begins at the column address specified.

Additional pages within the OTP area can be read by repeating the READ OTP PAGE (00h-30h) command. The READ OTP PAGE (00h-30h) command is compatible with the CHANGE READ COL-UMN (05h-E0h) command. Use of the READ STATUS ENHANCED (78h) and CHANGE READ COLUMN ENHANCED (06h-E0h) commands are prohibited.

Figure 64: READ OTP PAGE (00h-30h) Operation


26 Multi-Plane Operations

Each NAND Flash logical unit (LUN) is divided into multiple physical planes. Each plane contains a cache register and a data register independent of the other planes. The planes are addressed via the low-order block address bits. Specific details are provided in Device and Array Organization.

Multi-plane operations make better use of the NAND Flash arrays on these physical planes by performing concurrent READ, PROGRAM, or ERASE operations on multiple planes, significantly improving system performance. Multi-plane operations must be of the same type across the planes; for example, it is not possible to perform a PROGRAM operation on one plane with an ERASE operation on another.

When issuing MULTI-PLANE PROGRAM or ERASE operations, use the READ STATUS (70h) command and check whether the previous operation(s) failed. If the READ STATUS (70h) command indicates that an error occurred (FAIL = 1 and/or FAILC = 1), use the READ STATUS ENHANCED (78h) command—time for each plane—to determine which plane operation failed.

26.1 Multi-Plane Addressing

Multi-plane commands require an address per operational plane. For a given multi-plane operation, these addresses are subject to the following requirements:

- The LUN address bit(s) must be identical for all of the issued addresses.
- The plane select bit, BA[8], must be different for each issued address.
- The page address bits, PA[7:0], must be identical for each issued address.

The READ STATUS (70h) command should be used following MULTI-PLANE PROGRAM PAGE and ERASE BLOCK operations on a single die (LUN).



27 Interleaved Die (Multi-LUN) Operations

In devices that have more than one die (LUN) per target, it is possible to improve performance by interleaving operations between the die (LUNs). An interleaved die (multi-LUN) operation is one that is issued to an idle die (LUN) (RDY = 1) while another die (LUN) is busy (RDY = 0).

Interleaved die (multi-LUN) operations are prohibited following RESET (FFh, FCh), identification (90h, ECh, EDh), and configuration (EEh, EFh) operations until ARDY = 1 for all of the die (LUNs) on the target.

During an interleaved die (multi-LUN) operation, there are two methods to determine operation completion. The R/B# signal indicates when all of the die (LUNs) have finished their operations. R/B# remains LOW while any die (LUN) is busy. When R/B# goes HIGH, all of the die (LUNs) are idle and the operations are complete. Alternatively, the READ STATUS ENHANCED (78h) command can report the status of each die (LUN) individually.

If a die (LUN) is performing a cache operation, like PROGRAM PAGE CACHE (80h-15h), then the die (LUN) is able to accept the data for another cache operation when status register bit 6 is 1. All operations, including cache operations, are complete on a die when status register bit 5 is 1.

Use the READ STATUS ENHANCED (78h) command to monitor status for the addressed die (LUN). When multi-plane commands are used with interleaved die (multi-LUN) operations, the multi-plane commands must also meet the requirements, see Multi-Plane Operations for details. After the READ STATUS ENHANCED (78h) command has been issued, the READ STATUS (70h) command may be issued for the previously addressed die (LUN).

See Command Definitions for the list of commands that can be issued while other die (LUNs) are busy.

During an interleaved die (multi-LUN) operation that involves a PROGRAM-series (80h-10h, 80h-15h, 80h-11h) operation and a READ operation, the PROGRAM-series operation must be issued before the READ-series operation. The data from the READ series operation must be output to the host before the next PROGRAM-series operation is issued. This is because the 80h command clears the cache register contents of all cache registers on all planes.



28 Error Management

Each NAND Flash die (LUN) is specified to have a minimum number of valid blocks (NVB) of the total available blocks. This means the die (LUNs) could have blocks that are invalid when shipped from the factory. An invalid block is one that contains at least one page that has more bad bits than can be corrected by the minimum required ECC. Additional blocks can develop with use. However, the total number of available blocks per die (LUN) will not fall below NVB during the endurance life of the product.

Although NAND Flash memory devices could contain bad blocks, they can be used quite reliably in systems that provide bad-block management and error-correction algorithms. This type of software environment ensures data integrity.

Internal circuitry isolates each block from other blocks, so the presence of a bad block does not affect the operation of the rest of the NAND Flash array.

NAND Flash devices are shipped from the factory erased. The factory identifies invalid blocks before shipping by attempting to program the bad-block mark into every location in the first page of each invalid block. It may not be possible to program every location with the bad-block mark. However, the first spare area location in each bad block is guaranteed to contain the bad-block mark. This method is compliant with ON-Flash Factory Defect Mapping requirements. See the following table for the first spare area location and the bad-block mark.

System software should check the first spare area location on the first page of each block prior to performing any PROGRAM or ERASE operations on the NAND Flash device. A bad block table can then be created, enabling system software to map around these areas. Factory testing is performed under worst case conditions. Because invalid blocks could be marginal, it may not be possible to recover this information if the block is erased.

Over time, some memory locations may fail to program or erase properly. In order to ensure that data is stored properly over the life of the NAND Flash device, the following precautions are required:

- Always check status after a PROGRAM or ERASE operation
- Under typical conditions, use the minimum required ECC (see table below)
- Use bad-block management and wear-leveling algorithms

The first block (physical block address 00h) for each CE# is guaranteed to be valid with ECC when shipped from the factory.

Table 19: Error Management Details

Description	Requirement
Minimum number of valid blocks (NVB) per LUN	3996
Total available blocks per LUN	4096
First spare area location	Byte 8192
Bad-block mark	00h
Minimum required ECC	40-bit ECC per 1117 bytes of data



29 Shared Pages

In MLC NAND Flash devices, each memory cell contains two bits of data. These bits are distributed across two NAND pages. Pages within a NAND block that share the same NAND memory cells are referred to as shared pages. If any program operation is interrupted (for example, power loss or reset), data in previously programmed shared pages can also be corrupted.

The least significant numbered shared page must be programmed before the most significant numbered page of that pair can be programmed.

Table 20: Shared Pages

Shared Pages		Shared Pages	
0	4	126	132
1	5	127	133
2	8	130	136
3	9	131	137
6	12	134	140
7	13	135	141
10	16	138	144
11	17	139	145
14	20	142	148
15	21	143	149
18	24	146	152
19	25	147	153
22	28	150	156
23	29	151	157
26	32	154	160
27	33	155	161
30	36	158	164
31	37	159	165
34	40	162	168
35	41	163	169
38	44	166	172
39	45	167	173
42	48	170	176
43	49	171	177
46	52	174	180
47	53	175	181
50	56	178	184
51	57	179	185
54	60	182	188
55	61	183	189



Table 20: Shared Pages (Continued)

Shared Pages		Shared Pages	
58	64	186	192
59	65	187	193
62	68	190	196
63	69	191	197
66	72	194	200
67	73	195	201
70	76	198	204
71	77	199	205
74	80	202	208
75	81	203	209
78	84	206	212
79	85	207	213
82	88	210	216
83	89	211	217
86	92	214	220
87	93	215	221
90	96	218	224
91	97	219	225
94	100	222	228
95	101	223	229
98	104	226	232
99	105	227	233
102	108	230	236
103	109	231	237
106	112	234	240
107	113	235	241
110	116	238	244
111	117	239	245
114	120	242	248
115	121	243	249
118	124	246	252
119	125	247	253
122	128	250	254
123	129	251	255



30 Output Drive Impedance

Because NAND Flash is designed for use in systems that are typically point-to-point connections, an option to control the drive strength of the output buffers is provided. Drive strength should be selected based on the expected loading of the memory bus. There are four supported settings for the output drivers: overdrive 2, overdrive 1, nominal, and under drive.

The nominal output drive strength setting is the power-on default value. The host can select a different drive strength setting using the SET FEATURES (EFh) command.

The output impedance range from minimum to maximum covers process, voltage, and temperature variations. Devices are not guaranteed to be at the nominal line.

Table 21: Output Drive Strength Test Conditions (VCCQ = 1.7–1.95V)

Range	Process	Voltage	Temperature
Maximum	Fast-Fast	1.95V	-25°C
Nominal	Typical-Typical	1.8V	+25°C
Minimum	Slow-Slow	1.7V	+85°C

Table 22: Output Drive Strength Impedance Values (VCCQ = 1.7–1.95V)

Output Strength	Rpd/Rpu	VOUT to VSSQ	Minimum	Nominal	Maximum	Unit
Overdrive 2	Rpd	VCCQ × 0.2	7.5	13.5	34	ohms
		VCCQ × 0.5	9	18	31	ohms
		VCCQ × 0.8	11	23.5	44	ohms
	Rpu	VCCQ × 0.2	11	23.5	44	ohms
		VCCQ × 0.5	9	18	31	ohms
		VCCQ × 0.8	7.5	13.5	34	ohms
Overdrive 1	Rpd	VCCQ × 0.2	10.5	19	47	ohms
		VCCQ × 0.5	13	25	44	ohms
		VCCQ × 0.8	16	32.5	61.5	ohms
	Rpu	VCCQ × 0.2	16	32.5	61.5	ohms
		VCCQ × 0.5	13	25	44	ohms
		VCCQ × 0.8	10.5	19	47	ohms
Nominal	Rpd	VCCQ × 0.2	15	27	66.5	ohms
		VCCQ × 0.5	18	35	62.5	ohms
		VCCQ × 0.8	22	52	88	ohms
	Rpu	VCCQ × 0.2	22	52	88	ohms
		VCCQ × 0.5	18	35	62.5	ohms



		$V_{CCQ} \times 0.8$	15	27	66.5	ohms
--	--	----------------------	----	----	------	------

Table 22: Output Drive Strength Impedance Values ($V_{CCQ} = 1.7-1.95V$) (Continued)

Output Strength	Rpd/Rpu	V_{OUT} to V_{SSQ}	Minimum	Nominal	Maximum	Unit
Underdrive	Rpd	$V_{CCQ} \times 0.2$	21.5	39	95	ohms
		$V_{CCQ} \times 0.5$	26	50	90	ohms
		$V_{CCQ} \times 0.8$	31.5	66.5	126.5	ohms
	Rpu	$V_{CCQ} \times 0.2$	31.5	66.5	126.5	ohms
		$V_{CCQ} \times 0.5$	26	50	90	ohms
		$V_{CCQ} \times 0.8$	21.5	39	95	ohms

Table 23: Output Drive Strength Conditions ($V_{CCQ} = 2.7-3.6V$)

Range	Process	Voltage	Temperature
Maximum	Fast-Fast	3.6V	-40°C
Nominal	Typical-Typical	3.3V	+25°C
Minimum	Slow-Slow	2.7V	+85°C

Table 24: Output Drive Strength Impedance Values ($V_{CCQ} = 2.7-3.6V$)

Output Strength	Rpd/Rpu	V_{OUT} to V_{SSQ}	Minimum	Nominal	Maximum	Unit
Overdrive 2	Rpd	$V_{CCQ} \times 0.2$	7.0	16.2	28.7	ohms



Overdrive 1	Rpu	VCCQ X 0.5	9.0	18.0	36.0	ohms	
		VCCQ X 0.8	11.8	21.0	50.0	ohms	
		VCCQ X 0.2	11.8	21.0	50.0	ohms	
	Rpd	Rpu	VCCQ X 0.5	9.0	18.0	36.0	ohms
			VCCQ X 0.8	7.0	14.0	28.7	ohms
			VCCQ X 0.2	9.3	22.3	40.0	ohms
		Rpd	VCCQ X 0.5	12.6	25.0	50.0	ohms
			VCCQ X 0.8	16.3	29.0	68.0	ohms
			VCCQ X 0.2	16.3	29.0	68.0	ohms
Nominal	Rpd	Rpu	VCCQ X 0.2	12.6	25.0	50.0	ohms
			VCCQ X 0.5	12.6	25.0	50.0	ohms
			VCCQ X 0.8	9.3	19.0	40.0	ohms
	Rpu	VCCQ X 0.2	12.8	32.0	58.0	ohms	
		VCCQ X 0.5	18.0	35.0	70.0	ohms	
		VCCQ X 0.8	23.0	40.0	95.0	ohms	

Table 24: Output Drive Strength Impedance Values (V_{CCQ} = 2.7–3.6V) (Continued)

Output Strength	Rpd/Rpu	V _{OUT} to V _{SSQ}	Minimum	Nominal	Maximum	Unit
Underdrive	Rpd	VCCQ X 0.2	18.4	45.0	80.0	ohms
		VCCQ X 0.5	25.0	50.0	100.0	ohms
		VCCQ X 0.8	32.0	57.0	136.0	ohms
	Rpu	VCCQ X 0.2	32.0	57.0	136.0	ohms
		VCCQ X 0.5	25.0	50.0	100.0	ohms
		VCCQ X 0.8	18.4	45.0	80.0	ohms

Table 25: Pull-Up and Pull-Down Output Impedance Mismatch

Drive Strength	Minimum	Maximum	Unit	Notes
Overdrive 2	0	6.3	ohms	1, 2
Overdrive 1	0	8.8	ohms	1, 2
Nominal	0	12.3	ohms	1, 2
Underdrive	0	17.5	ohms	1, 2

Notes:

- Mismatch is the absolute value between pull-up and pull-down impedances. Both are measured at the same temperature and voltage.
- Test conditions: V_{CCQ} = V_{CCQ} (MIN), V_{OUT} = V_{CCQ} × 0.5, T_A = TOPER.



31 AC Overshoot/Undershoot Specifications

The supported AC overshoot and undershoot area depends on the timing mode selected by the host.

Table 26: Asynchronous Overshoot/Undershoot Parameters

Parameter	Timing Mode						Unit
	0	1	2	3	4	5	
Maximum peak amplitude provided for overshoot area	1	1	1	1	1	1	V
Maximum peak amplitude provided for undershoot area	1	1	1	1	1	1	V
Maximum overshoot area above V_{CCQ}	3	3	3	3	3	3	V-ns
Maximum undershoot area below V_{SSQ}	3	3	3	3	3	3	V-ns

Table 27: Synchronous Overshoot/Undershoot Parameters

Parameter	Timing Mode						Unit
	0	1	2	3	4	5	
Maximum peak amplitude provided for overshoot area	1	1	1	1	1	1	V



Maximum peak amplitude provided for undershoot area	1	1	1	1	1	1	V
Maximum overshoot area above V_{CCQ}	3	3	3	2.25	1.8	1.5	V-ns
Maximum undershoot area below V_{SSQ}	3	3	3	2.25	1.8	1.5	V-ns

Figure 65: Overshoot

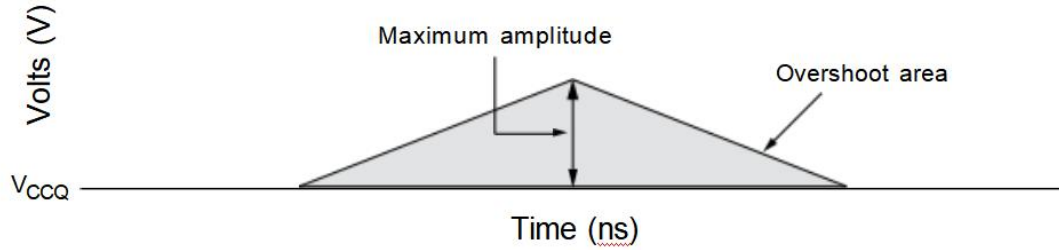
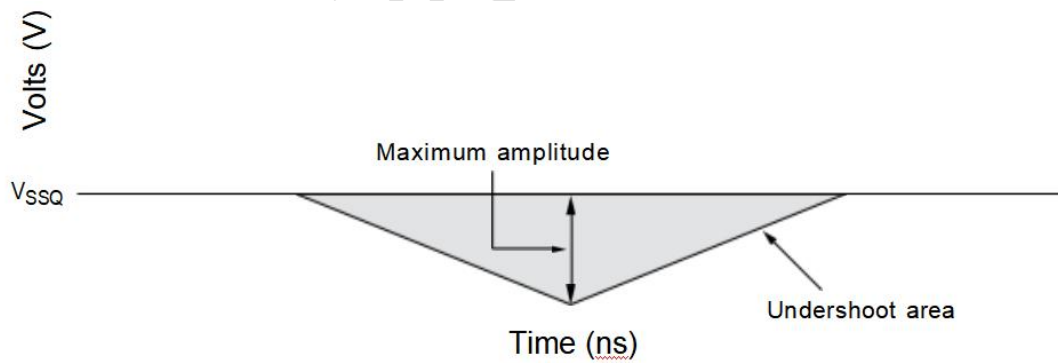


Figure 66: Undershoot





32 Synchronous Input Slew Rate

Though all AC timing parameters are tested with a nominal input slew rate of 1 V/ns, it is possible to run the device at a slower slew rate. The input slew rates shown below are sampled, and not 100% tested. When using slew rates slower than the minimum values, timing must be derated by the host.

Table 28: Test Conditions for Input Slew Rate

Parameter	Value
Rising edge	VIL(DC)To VIH(AC)
Falling edge	VIH(DC)To VIL(AC)
Temperature range	TA

Table 29: Input Slew Rate (V_{CCQ} = 1.7–1.95V)

Command/ Address and DQ V/ns	CLK/DQS Slew Rate Derating VIH(AC)/VIL(AC)= 540mV, VIH(DC)/VIL(DC)= 360mV																Unit
	1		0.9		0.8		0.7		0.6		0.5		0.4		0.3		
	set	hold	set	hold	set	hold	set	hold	set	hold	set	hold	set	hold	set	hold	
1	0	0	0	0	-	-	-	-	-	-	-	-	-	-	-	-	ps
0.9	0	0	0	0	0	0	-	-	-	-	-	-	-	-	-	-	ps
0.8	-	-	0	0	0	0	0	0	-	-	-	-	-	-	-	-	ps
0.7	-	-	-	-	0	0	0	0	0	0	-	-	-	-	-	-	ps
0.6	-	-	-	-	-	-	0	0	0	0	0	0	-	-	-	-	ps
0.5	-	-	-	-	-	-	-	-	0	0	0	0	180	180	-	-	ps
0.4	-	-	-	-	-	-	-	-	-	-	180	180	360	360	660	660	ps
0.3	-	-	-	-	-	-	-	-	-	-	-	-	660	660	920	920	ps

Table 30: Input Slew Rate (V_{CCQ}= 2.7–3.6V)

Command/ Address and DQ V/ns	CLK/DQS Slew Rate Derating VIH(AC)/VIL(AC)= 990mV, VIH(DC)/VIL(DC)= 660mV																Unit
	1		0.9		0.8		0.7		0.6		0.5		0.4		0.3		
	set	hold	set	hold	set	hold	set	hold	set	hold	set	hold	set	hold	set	hold	
1	0	0	0	0	-	-	-	-	-	-	-	-	-	-	-	-	ps
0.9	0	0	0	0	0	0	-	-	-	-	-	-	-	-	-	-	ps
0.8	-	-	0	0	0	0	0	0	-	-	-	-	-	-	-	-	ps
0.7	-	-	-	-	0	0	0	0	0	0	-	-	-	-	-	-	ps
0.6	-	-	-	-	-	-	0	0	0	0	0	0	-	-	-	-	ps
0.5	-	-	-	-	-	-	-	-	0	0	0	0	330	330	-	-	ps
0.4	-	-	-	-	-	-	-	-	-	-	330	330	660	660	1210	1210	ps
0.3	-	-	-	-	-	-	-	-	-	-	-	-	1210	1210	1760	1760	ps



33 Output Slew Rate

The output slew rate is tested using the following setup with only one die per DQ channel.

Table 31: Test Conditions for Output Slew Rate

Parameter	Value
VOL(DC)	$0.3 \times V_{CCQ}$
VOH(DC)	$0.7 \times V_{CCQ}$
VOL(AC)	$0.2 \times V_{CCQ}$
VOH(AC)	$0.8 \times V_{CCQ}$
Rising edge (tRISE)	VOL(DC) to VOH(AC)
Falling edge (tFALL)	VOH(DC) to VOL(AC)
Output capacitive load (C _{LOAD})	5pF
Temperature range	TA

Table 32: Output Slew Rate ($V_{CCQ} = 1.7\text{--}1.95\text{V}$)

Output Drive Strength	Min	Max	Unit
Overdrive 2	1	5.5	V/ns
Overdrive 1	0.85	5	V/ns
Nominal	0.75	4	V/ns
Underdrive	0.6	4	V/ns

Table 33: Output Slew Rate ($V_{CCQ} = 2.7\text{--}3.6\text{V}$)

Output Drive Strength	Min	Max	Unit
Overdrive 2	1.5	10.0	V/ns
Overdrive 1	1.5	9.0	V/ns
Nominal	1.2	7.0	V/ns
Underdrive	1.0	5.5	V/ns

34 Power Cycle Requirements

Upon power-down the NAND device requires a maximum voltage and minimum time that the host must hold VCC and VCCQ below the voltage prior to power-on.



Table 34: Power Cycle Requirements

Parameter	Value	Unit
Maximum Vcc/Vccq	100	mV
Minimum time below Maximum Voltage	100	ns

MK FOUNFER CONFIDENTIAL



35 Electrical Specifications

Stresses greater than those listed can cause permanent damage to the device. This is a stress rating only, and functional operation of the device at these or any other conditions above those indicated in the operational sections of this specification is not guaranteed. Exposure to absolute maximum rating conditions for extended periods can affect reliability.

Table 35: Absolute Maximum Ratings by Device

Parameter	Symbol	Min ¹	Max ¹	Unit
Voltage input	V _{IN}	-0.6	4.6	V
V _{CC} supply voltage	V _{CC}	-0.6	4.6	V
V _{CCQ} supply voltage	V _{CCQ}	-0.6	4.6	V
Storage temperature	T _{STG}	-65	150	°C

Note: 1. Voltage on any pin relative to VSS.

Table 36: Recommended Operating Conditions

Parameter	Symbol	Min	Typ	Max	Unit	
Operating temperature	Commercial	T _A	0	–	70	°C
V _{CC} supply voltage	V _{CC}	2.7	3.3	3.6	V	
V _{CCQ} supply voltage (1.8V)	V _{CCQ}	1.7	1.8	1.95	V	
V _{CCQ} supply voltage (3.3V)		2.7	3.3	3.6	V	
V _{SS} ground voltage	V _{SS}	0	0	0	V	

Table 37: Valid Blocks per LUN

Parameter	Symbol	Min	Max	Unit	Notes
Valid block number	NVB	3996	4096	Blocks	1

Note:

1. Invalid blocks are block that contain one or more bad bits beyond ECC. The device may contain bad blocks upon shipment. Additional bad blocks may develop over time; however, the total number of available blocks will not drop below NVB during the endurance life of the device. Do not erase or program blocks marked invalid from the factory.



Table 38: Capacitance: 100-Ball BGA Package

Description	Symbol	Single Die/Dual Die Package			Quad Die Package			Octal Die Package			Unit	Notes
		Min	Typ	Max	Min	Typ	Max	Min	Typ	Max		
Input capacitance (CLK)	C _{CK}	3.5	4.0	4.5	5.2	6.2	7.2	8.5	10.5	12.5	pF	3
Input capacitance (ALE, CLE, W/R#)	C _{IN}	3.5	4	4.5	5.8	6.8	7.8	8.5	10.5	12.5	pF	3
Input/output capacitance (DQ[7:0], DQS)	C _{IO}	4	4.5	5	7	8	9	12.5	14.5	16.5	pF	3
Input capacitance (CE#, WP#)	C _{OTHER}	–	–	5	–	–	10	–	–	13	pF	
Delta clock capacitance	DC _{CK}	–	–	0.25	–	–	0.5	–	–	1	pF	
Delta input capacitance	DC _{IN}	–	–	0.5	–	–	1	–	–	2	pF	
Delta input/output capacitance	DC _{IO}	–	–	0.5	–	–	1	–	–	2	pF	

- Notes:
1. Verified in device characterization; not 100% tested.
 2. Test conditions: T_A = 25°C, f = 100 MHz, V_{IN} = 0V.
 3. Values for C_{CK}, C_{IN} and C_{IO} (TYP) are estimates.

Table 39: Capacitance: 48-Pin TSOP Package

Description	Symbol	Device	Max	Unit	Notes
Input capacitance – ALE, CE#, CLE, RE#, WE#, WP#	C _{IN}	Single die package	10	pF	1
		Dual die package	14		
		Quad die package	18		
Input/output capacitance – DQ[7:0], DQS	C _{IO}	Single die package	6	pF	1
		Dual die package	10		
		Quad die package	18		

Note:

1. These parameters are verified in device characterization and are not 100% tested. Test conditions: TC = 25°C; f = 1 MHz; V_{in} = 0V.



Table 40: Test Conditions

Parameter	Value	Notes
Rising input transition	$V_{IL(DC)}$ to $V_{IH(AC)}$	1
Falling input transition	$V_{IH(DC)}$ to $V_{IL(AC)}$	1
Input rise and fall slew rates	1 V/ns	–
Input and output timing levels	$V_{CCQ}/2$	–
Output load: Nominal output drive strength	$C_L = 5pF$	2, 3

Notes:

1. The receiver will effectively switch as a result of the signal crossing the AC input level; it will remain in that status as long as the signal does not ring back above (below) the DC input LOW (HIGH) level.
2. Transmission line delay is assumed to be very small.
3. This test setup applies to all package configurations.

36 Electrical Specifications

DC Characteristics and Operating Conditions (Asynchronous)

Table 41: DC Characteristics and Operating Conditions (Asynchronous Interface)

Parameter	Conditions	Symbol	Min ¹	Typ ¹	Max ¹	Unit
Array read current (active)	–	I_{CC1_A}	–	25	50	mA
Array program current (active)	–	I_{CC2_A}	–	25	50	mA
Erase current (active)	–	I_{CC3_A}	–	25	50	mA
I/O burst read current	$t_{RC} = t_{RC} (MIN)$; $I_{OUT} = 0mA$	I_{CC4R_A}	–	5	10	mA
I/O burst write current	$t_{WC} = t_{WC} (MIN)$	I_{CC4w_A}	–	5	10	mA
Bus idle current	–	I_{CC5_A}	–	3	5	mA
Current during first RESET command after power-on	–	I_{CC6}	–	–	10	mA
Standby current - V_{CC}	$CE\# = V_{CCQ} - 0.2V$; $WP\# = 0V/V_{CCQ}$	I_{SB}	–	10	50	μA
Standby current - V_{CCQ}	$CE\# = V_{CCQ} - 0.2V$; $WP\# = 0V/V_{CCQ}$	I_{SBQ}	–	3	10	μA
Staggered power-up current	$t_{RISE} = 1ms$; $C_{LINE} = 0.1\mu F$	I_{ST}	–	–	10	mA

Note: 1. All values are per die (LUN) unless otherwise specified.

37 Electrical Specifications

DC Characteristics and Operating Conditions



(Synchronous)

Table 42: DC Characteristics and Operating Conditions (Synchronous Interface)

Parameter	Conditions	Symbol	Min ¹	Typ ¹	Max ¹	Unit
Array read current (active)	CE# = V _{IL} ; tCK = tCK (MIN)	I _{CC1_S}	–	25	50	mA
Array program current (active)	tCK = tCK (MIN)	I _{CC2_S}	–	25	50	mA
Erase current (active)	tCK = tCK (MIN)	I _{CC3_S}	–	25	50	mA
I/O burst read current	tCK = tCK (MIN); I _{OUT} = 0mA	I _{CC4R_S}	–	10	20	mA
I/O burst write current	tCK = tCK (MIN)	I _{CC4W_S}	–	10	20	mA
Bus idle current	tCK = tCK (MIN)	I _{CC5_S}	–	5	10	mA

Table 42: DC Characteristics and Operating Conditions (Synchronous Interface) (Continued)

Parameter	Conditions	Symbol	Min ¹	Typ ¹	Max ¹	Unit
Standby current - V _{CC}	CE# = V _{CCQ} - 0.2V; WP# = 0V/V _{CCQ}	I _{SB}	–	10	50	μA
Standby Current - V _{CCQ}	CE# = V _{CCQ} - 0.2V; WP# = 0V/V _{CCQ}	I _{SBQ}	–	3	10	μA

Note: 1. All values are per die (LUN) unless otherwise specified.

38 Electrical Specifications

DC Characteristics and Operating Conditions (V_{CCQ})

Table 43: DC Characteristics and Operating Conditions (3.3V V_{CCQ})

Parameter	Condition	Symbol	Min	Typ	Max	Unit	Notes
AC input high voltage	CE#, DQ[7:0], DQS, ALE, CLE, CLK (WE#), W/R# (RE#), WP#	V _{IH(AC)}	0.8 × V _{CCQ}	–	V _{CCQ} + 0.3	V	
AC input low voltage		V _{IL(AC)}	–0.3	–	0.2 × V _{CCQ}	V	
DC input high voltage	DQ[7:0], DQS, ALE, CLE, CLK (WE#), W/R# (RE#)	V _{IH(DC)}	0.7 × V _{CCQ}	–	V _{CCQ} + 0.3	V	
DC input low voltage		V _{IL(DC)}	–0.3	–	0.3 × V _{CCQ}	V	
Input leakage current	Any input V _{IN} = 0V to V _{CCQ} (all other pins under test = 0V)	I _{LI}	–	–	±10	μA	1
Output leakage current	DQ are disabled; V _{OUT} = 0V to V _{CCQ}	I _{LO}	–	–	±10	μA	1
Output low current (R/B#)	V _{OL} = 0.4V	I _{OL} (R/B#)	8	10	–	mA	2

Notes:

1. All leakage currents are per die (LUN). Two die (LUNs) have a maximum leakage current of ±20μA and four die (LUNs) have a maximum leakage current of ±40μA.

DC characteristics may need to be relaxed if R/B# pull-down strength is not set to full strength. See Table 14 (page 68) for additional details.

Table 44: DC Characteristics and Operating Conditions (1.8V V_{CCQ})

Parameter	Condition	Symbol	Min	Typ	Max	Unit	Notes
AC input high voltage	CE#, DQ[7:0], DQS, ALE, CLE, CLK (WE#), W/R# (R/E#), WP#	V _{IH(AC)}	0.8 × V _{CCQ}	–	V _{CCQ} + 0.3	V	
AC input low voltage		V _{IL(AC)}	–0.3	–	0.2 × V _{CCQ}	V	
DC input high voltage	DQ[7:0], DQS, ALE, CLE, CLK (WE#), W/R# (R/E#)	V _{IH(DC)}	0.7 × V _{CCQ}	–	V _{CCQ} + 0.3	V	
DC input low voltage		V _{IL(DC)}	–0.3	–	0.3 × V _{CCQ}	V	
Input leakage current	Any input V _{IN} = 0V to V _{CCQ} (all other pins under test = 0V)	I _{LI}	–	–	±10	μA	1
Output leakage current	DQ are disabled; V _{out} = 0V to V _{CCQ}	I _{LO}	–	–	±10	μA	1
Output low current (R/B#)	V _{OL} = 0.2V	I _{OL} (R/B#)	3	4	–	mA	2

Notes:

1. All leakage currents are per die (LUN). Two die (LUNs) have a maximum leakage current of ±20μA and four die (LUNs) have a maximum leakage current of ±40μA.

DC characteristics may need to be relaxed if R/B# pull-down strength is not set to full strength. See Table 14 (page 68) for additional details.

39 Electrical Specifications

AC Characteristics and Operating Conditions (Asynchronous)



Table 45: AC Characteristics: Asynchronous Command, Address, and Data

Parameter	Symbol	Mode 0		Mode 1		Mode 2		Mode 3		Mode 4		Mode 5		Unit	Notes
		Min	Max	Min	Max	Min	Max	Min	Max	Min	Max	Min	Max		
Clock period		100		50		35		30		25		20		ns	
Frequency		≈10		≈20		≈28		≈33		≈40		≈50		MHz	
ALE to data start	tADL	200	–	100	–	100	–	100	–	70	–	70	–	ns	1
ALE hold time	tALH	20	–	10	–	10	–	5	–	5	–	5	–	ns	
ALE setup time	tALS	50	–	25	–	15	–	10	–	10	–	10	–	ns	
ALE to RE# delay	tAR	25	–	10	–	10	–	10	–	10	–	10	–	ns	
CE# access time	tCEA	–	100	–	45	–	30	–	25	–	25	–	25	ns	
CE# hold time	tCH	20	–	10	–	10	–	5	–	5	–	5	–	ns	
CE# HIGH to output High-Z	tCHZ	–	100	–	50	–	50	–	50	–	30	–	30	ns	2
CLE hold time	tCLH	20	–	10	–	10	–	5	–	5	–	5	–	ns	
CLE to RE# delay	tCLR	20	–	10	–	10	–	10	–	10	–	10	–	ns	
CLE setup time	tCLS	50	–	25	–	15	–	10	–	10	–	10	–	ns	
CE# HIGH to output hold	tCOH	0	–	15	–	15	–	15	–	15	–	15	–	ns	
CE# setup time	tCS	70	–	35	–	25	–	25	–	20	–	15	–	ns	
Data hold time	tDH	20	–	10	–	5	–	5	–	5	–	5	–	ns	
Data setup time	tDS	40	–	20	–	15	–	10	–	10	–	7	–	ns	



Table 45: AC Characteristics: Asynchronous Command, Address, and Data (Continued)

Parameter	Symbol	Mode 0		Mode 1		Mode 2		Mode 3		Mode 4		Mode 5		Unit	Notes
		Min	Max	Min	Max	Min	Max	Min	Max	Min	Max	Min	Max		
Output High-Z to RE# LOW	tIR	10	–	0	–	0	–	0	–	0	–	0	–	ns	
RE# cycle time	tRC	100	–	50	–	35	–	30	–	25	–	20	–	ns	
RE# access time	tREA	–	40	–	30	–	25	–	20	–	20	–	16	ns	3
RE# HIGH hold time	tREH	30	–	15	–	15	–	10	–	10	–	7	–	ns	3
RE# HIGH to output hold	tRHOH	0	–	15	–	15	–	15	–	15	–	15	–	ns	3
RE# HIGH to WE# LOW	tRHW	200	–	100	–	100	–	100	–	100	–	100	–	ns	
RE# HIGH to output High-Z	tRHZ	–	200	–	100	–	100	–	100	–	100	–	100	ns	2, 3
RE# LOW to output hold	tRLOH	0	–	0	–	0	–	0	–	5	–	5	–	ns	3
RE# pulse width	tRP	50	–	25	–	17	–	15	–	12	–	10	–	ns	
Ready to RE# LOW	tRR	40	–	20	–	20	–	20	–	20	–	20	–	ns	
WE# HIGH to R/B# LOW	tWB	–	200	–	100	–	100	–	100	–	100	–	100	ns	4
WE# cycle time	tWC	100	–	45	–	35	–	30	–	25	–	20	–	ns	
WE# HIGH hold time	tWH	30	–	15	–	15	–	10	–	10	–	7	–	ns	
WE# HIGH to RE# LOW	tWHR	120	–	80	–	80	–	60	–	60	–	60	–	ns	
WE# pulse width	tWP	50	–	25	–	17	–	15	–	12	–	10	–	ns	
WP# transition to WE# LOW	tWW	100	–	100	–	100	–	100	–	100	–	100	–	ns	

Notes:

1. Timing for tADL begins in the address cycle, on the final rising edge of WE# and ends with the first rising edge of WE# for data input.
2. Data transition is measured $\pm 200\text{mV}$ from steady-steady voltage with load. This parameter is sampled and not 100 percent tested.
3. AC characteristics may need to be relaxed if output drive strength is not set to at least nominal.
4. Do not issue a new command during tWB, even if R/B# or RDY is ready.



40 Electrical Specifications

AC Characteristics and Operating Conditions(Synchronous)

Table 46: AC Characteristics: Synchronous Command, Address, and Data

Parameter	Symbol	Mode 0		Mode 1		Mode 2		Mode 3		Mode 4		Mode 5		Unit	Notes
		Min	Max	Min	Max	Min	Max	Min	Max	Min	Max	Min	Max		
Clock period		50		30		20		15		12		10		ns	
Frequency		≈20		≈33		≈50		≈67		≈83		≈100		MHz	
Access window of DQ[7:0] from CLK	tAC	3	20	3	20	3	20	3	20	3	20	3	20	ns	
ALE to data loading time	tADL	100	–	100	–	70	–	70	–	70	–	70	–	ns	
Command, address data delay	tCAD	25	–	25	–	25	–	25	–	25	–	25	–	ns	1
ALE, CLE, W/R# hold	tCALH	10	–	5	–	4	–	3	–	2.5	–	2	–	ns	
ALE, CLE, W/R# setup	tCALS	10	–	5	–	4	–	3	–	2.5	–	2	–	ns	
DQ hold – command, address	tCAH	10	–	5	–	4	–	3	–	2.5	–	2	–	ns	
DQ setup – command, address	tCAS	10	–	5	–	4	–	3	–	2.5	–	2	–	ns	
CE# hold	tCH	10	–	5	–	4	–	3	–	2.5	–	2	–	ns	
Average CLK cycle time	tCK (avg)	50	100	30	50	20	30	15	20	12	15	10	12	ns	3
Absolute CLK cycle time, from rising edge to rising edge	tCK (abs)	tCK (abs) MIN = tCK (avg) + tJIT (per) MIN tCK (abs) MAX = tCK (avg) + tJIT (per) MAX												ns	
CLK cycle HIGH	tCKH (abs)	0.43	0.57	0.43	0.57	0.43	0.57	0.43	0.57	0.43	0.57	0.43	0.57	tCK	4
CLK cycle LOW	tCKL (abs)	0.43	0.57	0.43	0.57	0.43	0.57	0.43	0.57	0.43	0.57	0.43	0.57	tCK	4
Data output end to W/R# HIGH	tCKWR	tCKWR(MIN) = RoundUp[(tDQSCK(MAX) + tCK)/tCK]												tCK	
CE# setup	tCS	35	–	25	–	15	–	15	–	15	–	15	–	ns	
Data In hold	tDH	5	–	2.5	–	1.7	–	1.3	–	1.1	–	0.8	–	ns	
Access window of DQS from CLK	tDQSCK	–	20	–	20	–	20	–	20	–	20	–	20	ns	
DQS, DQ[7:0] Driven by NAND	tDQSD	–	18	–	18	–	18	–	18	–	18	–	18	ns	



Table 46: AC Characteristics: Synchronous Command, Address, and Data (Continued)

Parameter	Symbol	Mode 0		Mode 1		Mode 2		Mode 3		Mode 4		Mode 5		Unit	Notes
		Min	Max	Min	Max	Min	Max	Min	Max	Min	Max	Min	Max		
DQS, DQ[7:0] to tri-state	tDQSHZ	–	20	–	20	–	20	–	20	–	20	–	20	ns	5
DQS input high pulse width	tDQSH	0.4	0.6	0.4	0.6	0.4	0.6	0.4	0.6	0.4	0.6	0.4	0.6	tCK	
DQS input low pulse width	tDQSL	0.4	0.6	0.4	0.6	0.4	0.6	0.4	0.6	0.4	0.6	0.4	0.6	tCK	
DQS-DQ skew	tDQSQ	–	5	–	2.5	–	1.7	–	1.3	–	1.0	–	0.85	ns	
Data input	tDQSS	0.75	1.25	0.75	1.25	0.75	1.25	0.75	1.25	0.75	1.25	0.75	1.25	tCK	
Data In setup	tDS	5	–	3	–	2	–	1.5	–	1.1	–	0.8	–	ns	
DQS falling edge from CLK rising – hold	tDSH	0.2	–	0.2	–	0.2	–	0.2	–	0.2	–	0.2	–	tCK	
DQS falling to CLK rising – set-up	tDSS	0.2	–	0.2	–	0.2	–	0.2	–	0.2	–	0.2	–	tCK	
Data valid window	tDVW	tDVW = tQH - tDQSQ												ns	
Half clock period	tHP	tHP = Min(tCKH,tCKL)												ns	
The deviation of a given tCK (abs) from atCK (avg)	tJIT (per)	–0.7	0.7	–0.7	0.7	–0.7	0.7	–0.6	0.6	–0.6	0.6	–0.5	0.5	ns	
DQ-DQS hold, DQS to first DQ to go nonvalid, per access	tQH	tQH = tHP - tQHS												ns	
Data hold skew factor	tQHS	–	6	–	3	–	2	–	1.5	–	1.2	–	1	ns	
Data output to command, address, or data input	tRHW	100	–	100	–	100	–	100	–	100	–	100	–	ns	
Ready to data output	tRR	20	–	20	–	20	–	20	–	20	–	20	–	ns	
CLK HIGH to R/B# LOW	tWB	–	100	–	100	–	100	–	100	–	100	–	100	ns	
Command cycle to data output	tWHR	80	–	80	–	80	–	80	–	80	–	80	–	ns	
DQS write pre-amble	tWPRE	1.5	–	1.5	–	1.5	–	1.5	–	1.5	–	1.5	–	tCK	



Table 46: AC Characteristics: Synchronous Command, Address, and Data (Continued)

Parameter	Symbol	Mode 0		Mode 1		Mode 2		Mode 3		Mode 4		Mode 5		Unit	Notes
		Min	Max	Min	Max	Min	Max	Min	Max	Min	Max	Min	Max		
DQS write post-ambale	tWPST	1.5	–	1.5	–	1.5	–	1.5	–	1.5	–	1.5	–	tCK	
W/R# LOW to data output cycle	tWRCK	20	–	20	–	20	–	20	–	20	–	20	–	ns	
WP# transition to command cycle	tWW	100	–	100	–	100	–	100	–	100	–	100	–	ns	

Notes:

1. Delay is from start of command to next command, address, or data cycle; start of address to next command, address, or data cycle; and end of data to start of next command, address, or data cycle.
2. This value is specified in the parameter page.
3. tCK(avg) is the average clock period over any consecutive 200-cycle window.
4. tCKH(abs) and tCKL(abs) include static offset and duty cycle jitter.
5. tDQSHZ begins when W/R# is latched HIGH by CLK. This parameter is not referenced to a specific voltage level; it specifies when the device outputs are no longer driving.

41 Electrical Specifications – Array Characteristics

Table 47: Array Characteristics

Parameter	Symbol	Typ	Max	Unit	Notes
Number of partial page programs	NOP	–	1	Cycles	1
ERASE BLOCK operation time	tBERS	3	10	ms	
Cache busy	tCBSY	35	2500	μs	
Change column setup time to data in/out or next command	tCCS	–	200	ns	
Dummy busy time	tDBSY	0.5	1	μs	
Cache read busy time	tRCBSY	3	75	μs	
Busy time for SET FEATURES and GET FEATURES operations	tFEAT	–	1	μs	
Busy time for interface change	tITC	–	1	μs	2
LAST PAGE PROGRAM operation time	tLPROG	–	–	μs	3
Busy time for OTP DATA PROGRAM operation if OTP is protected	tOBSY	–	40	μs	
Power-on reset time	tPOR	–	1	ms	
PROGRAM PAGE operation time	tPROG	1300	2500	μs	
READ PAGE operation time	tR	–	75	μs	
Device reset time (Read/Program/Erase)	tRST	–	5/10/500	μs	4

Notes:

1. The pages in the OTP Block have an NOP of 4.
2. $t_{ITC} (MAX)$ is the busy time when the interface changes from asynchronous to synchronous using the SET FEATURES (EFh) command or synchronous to asynchronous using the RESET (FFh) command. During the t_{ITC} time, any command, including READ STATUS (70h) and READ STATUS ENHANCED (78h), is prohibited.
3. $t_{LPROG} = t_{PROG} (last\ page) + t_{PROG} (last\ page - 1) - command\ load\ time (last\ page) - address\ load\ time (last\ page) - data\ load\ time (last\ page)$.
4. If RESET command is issued when the target is READY, the target goes busy for a maximum of $5\mu s$.

41.1 Asynchronous Interface Timing Diagrams

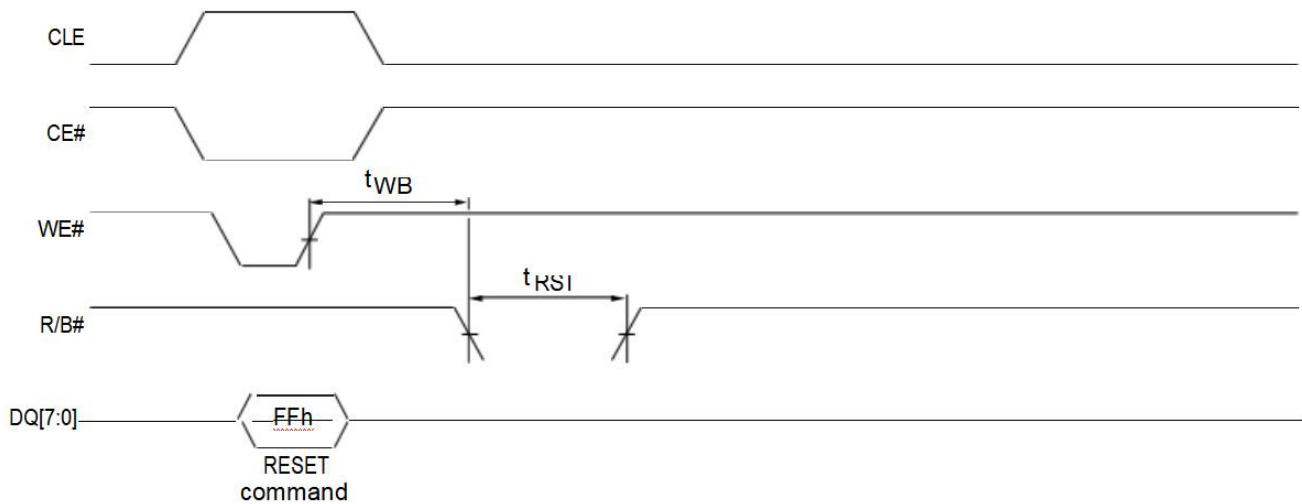
Figure 67: RESET Operation


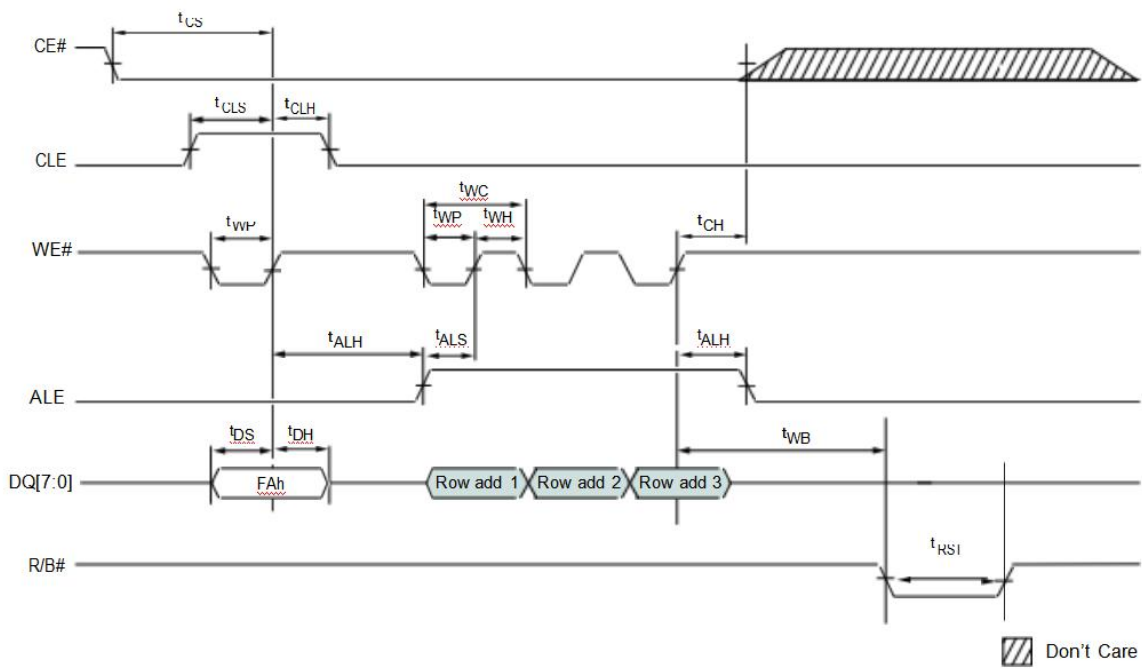
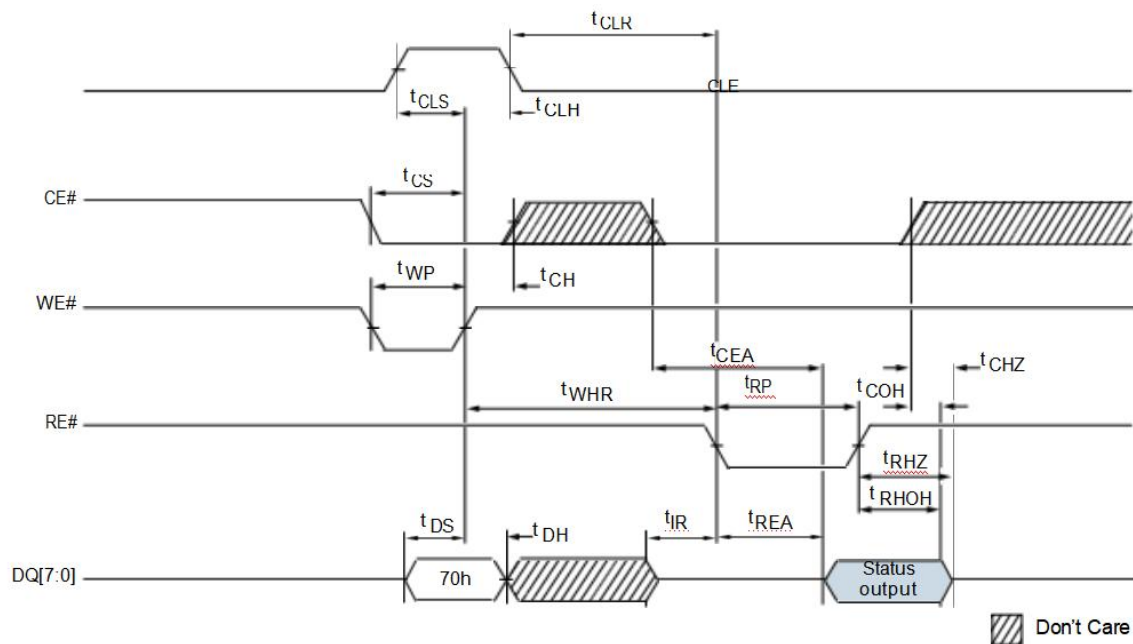
Figure 68: RESET LUN Operation

Figure 69: READ STATUS Cycle


Figure 70: READ STATUS ENHANCED Cycle

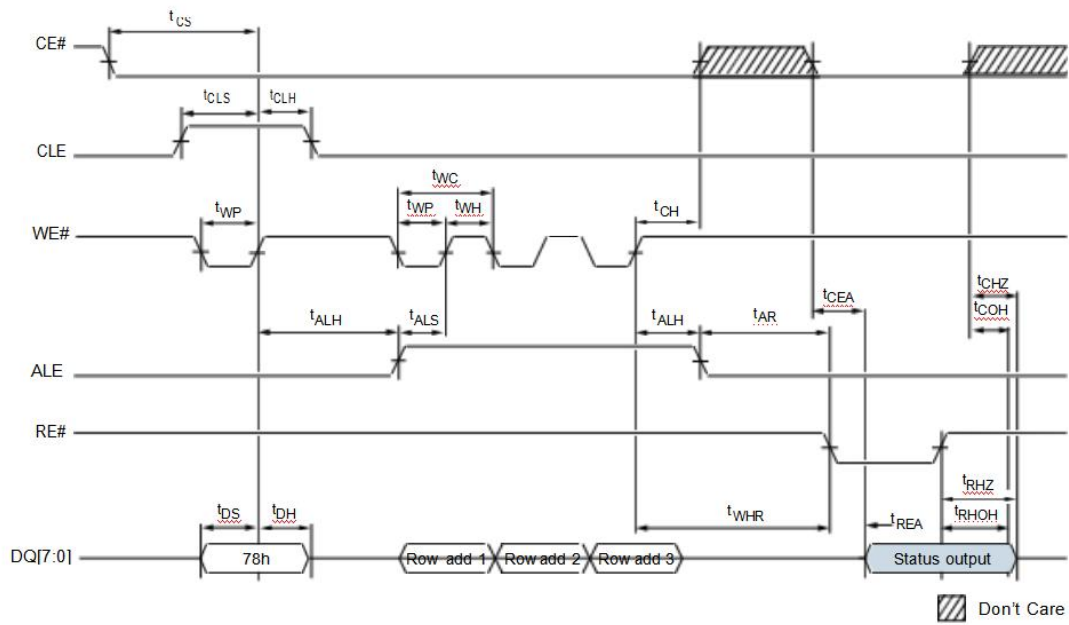


Figure 71: READ PARAMETER PAGE

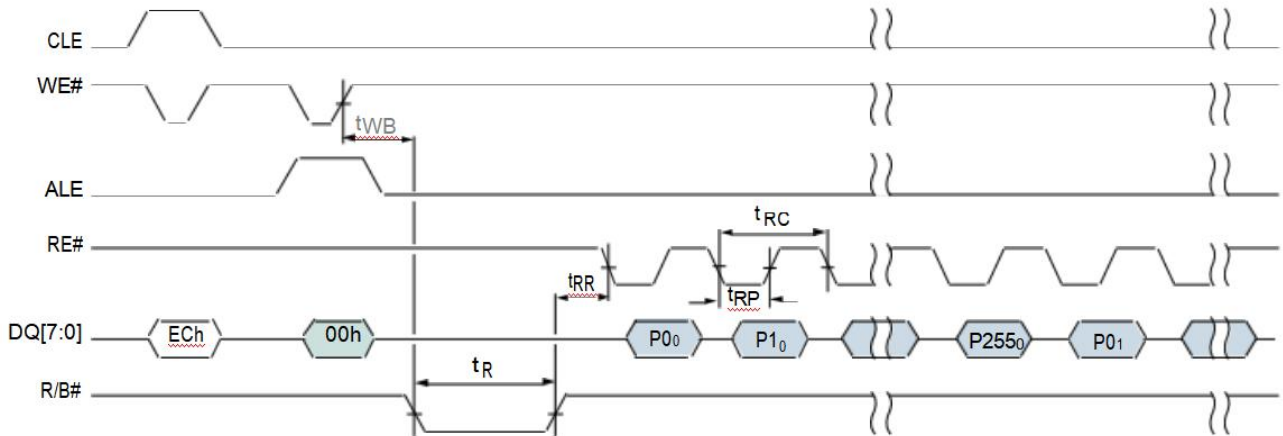


Figure 72: READ PAGE

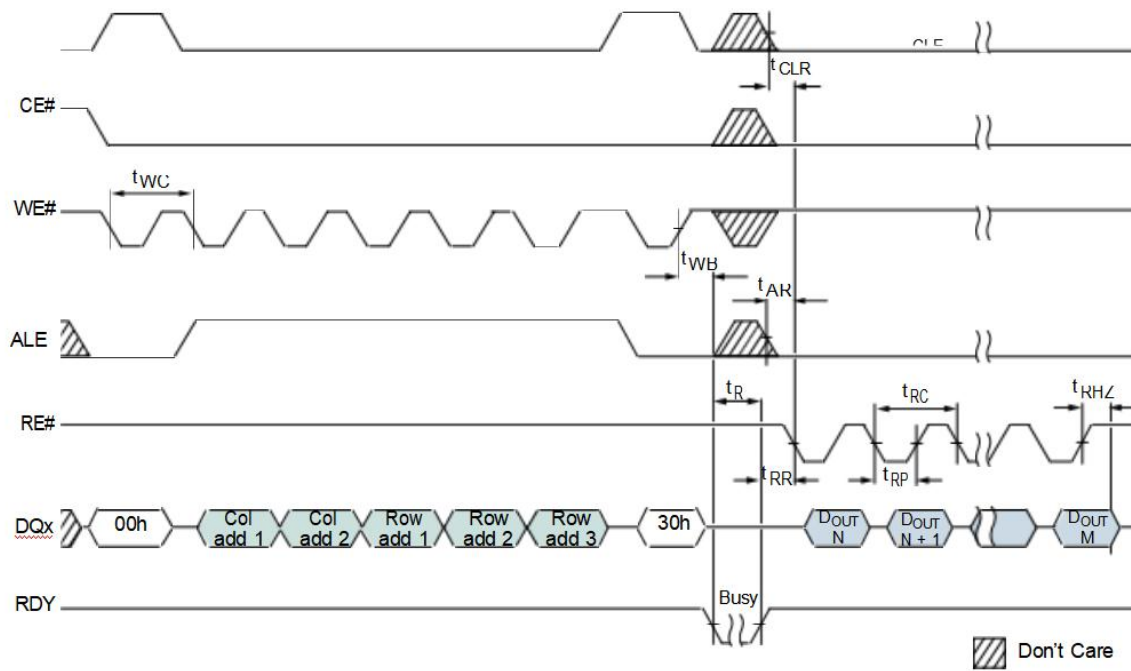


Figure 73: READ PAGE Operation with CE# "Don't Care"

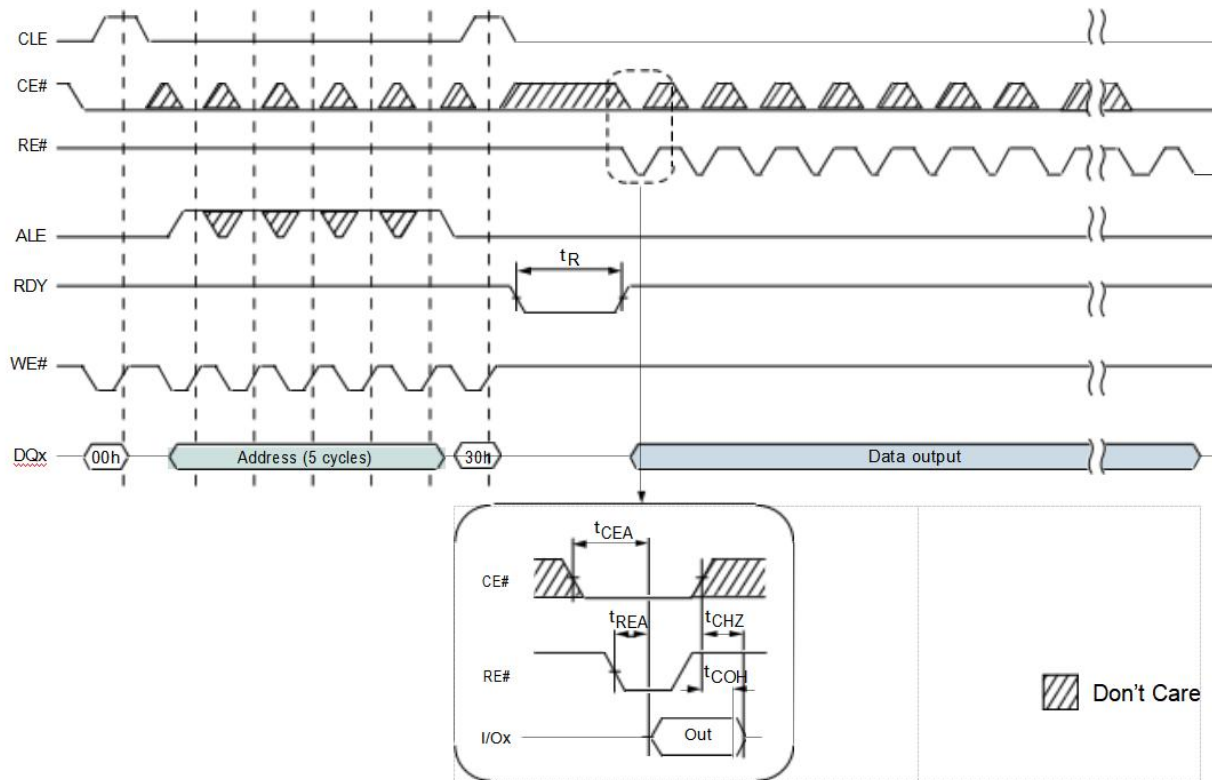




Figure 74: CHANGE READ COLUMN

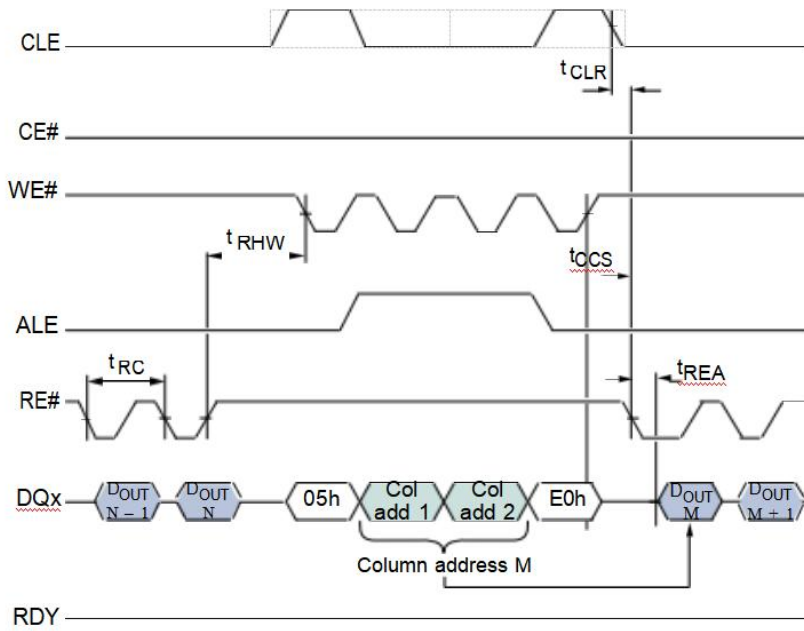
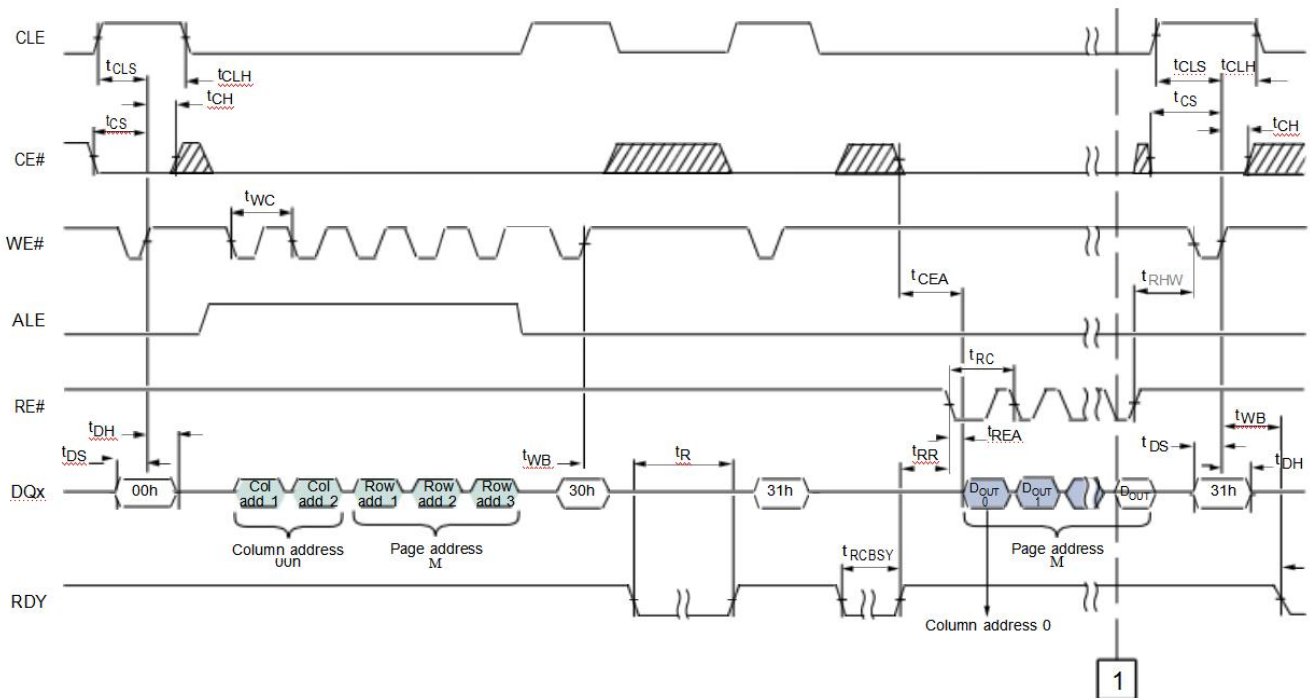
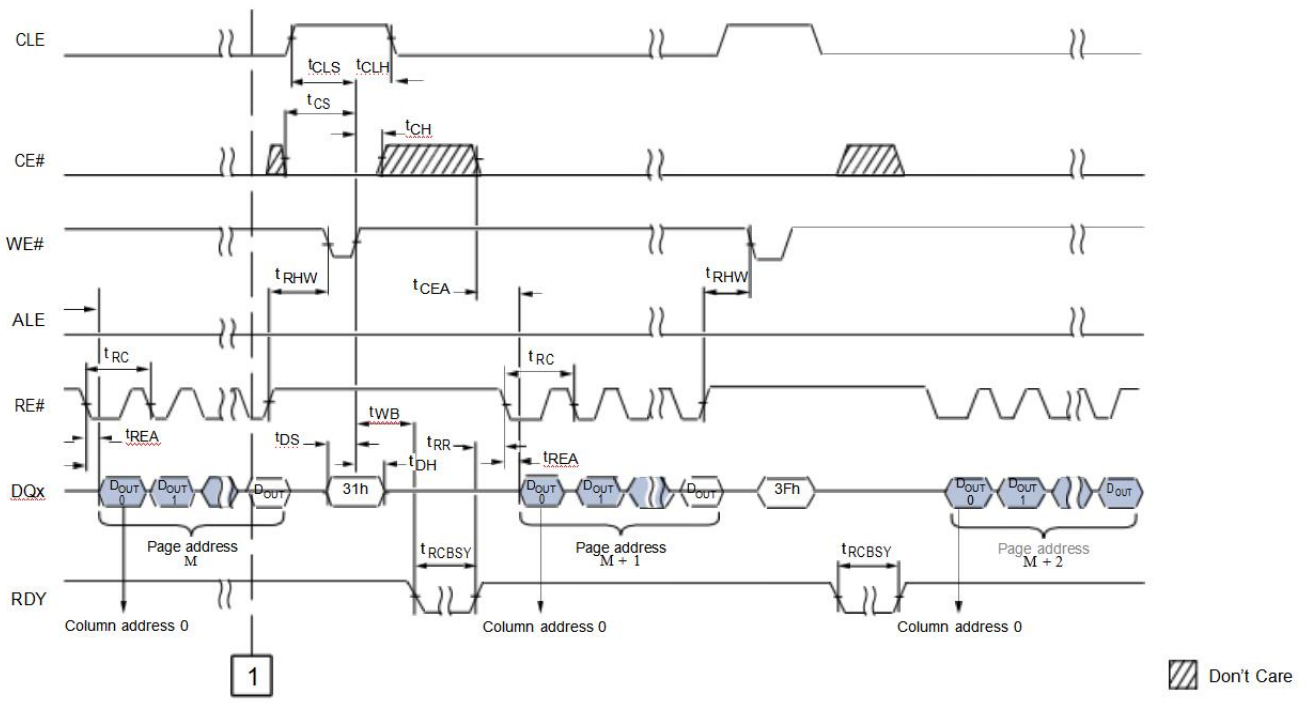


Figure 75: READ PAGE CACHE SEQUENTIAL





MK FOUNFER



Figure 76: READ PAGE CACHE RANDOM

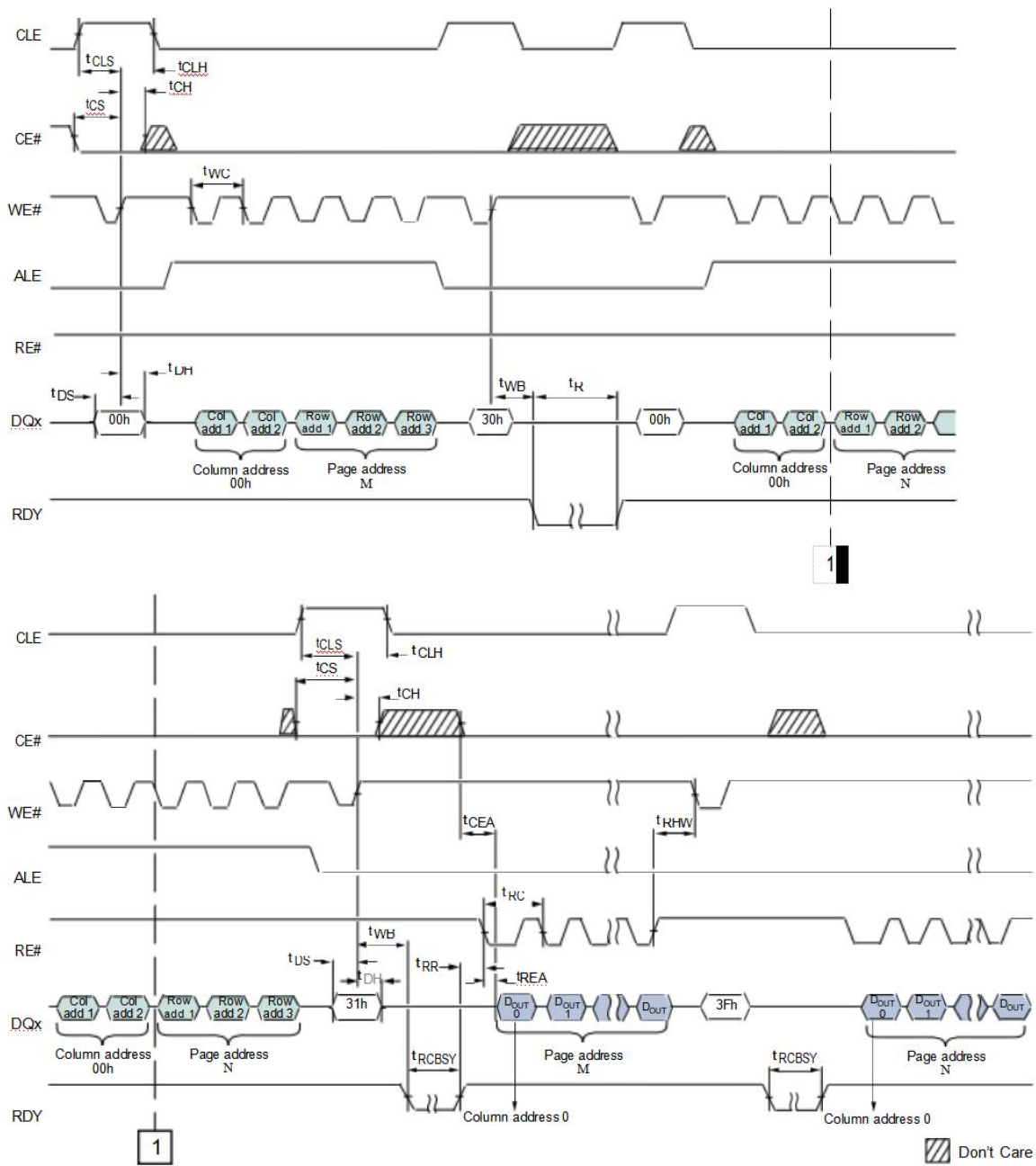


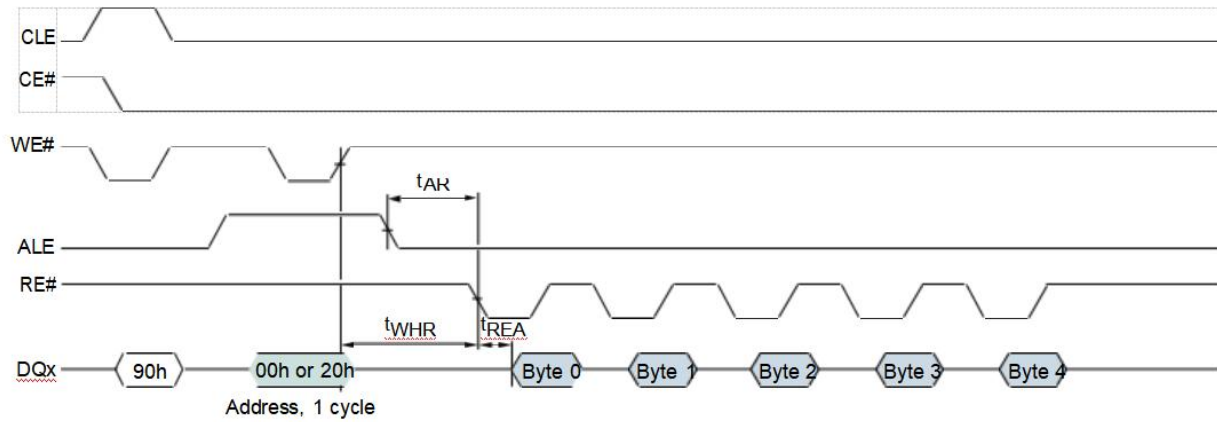
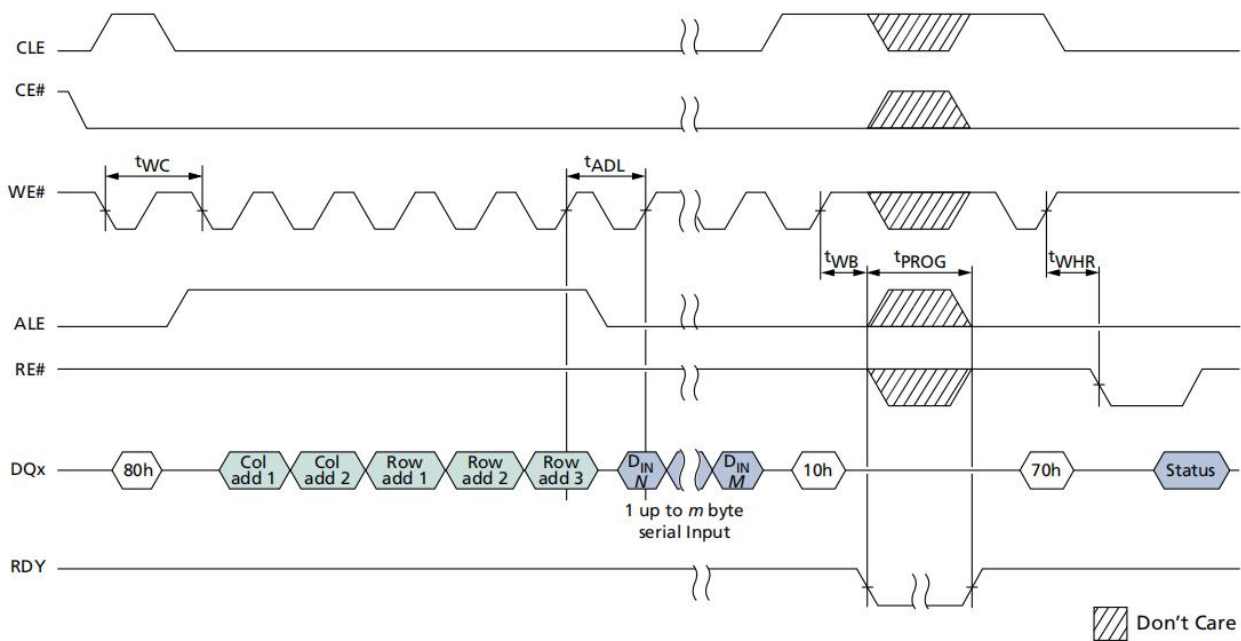
Figure 77: READ ID Operation

Figure 88: PROGRAM PAGE Operation


Figure 79: PROGRAM PAGE Operation with CE# “Don’t Care”

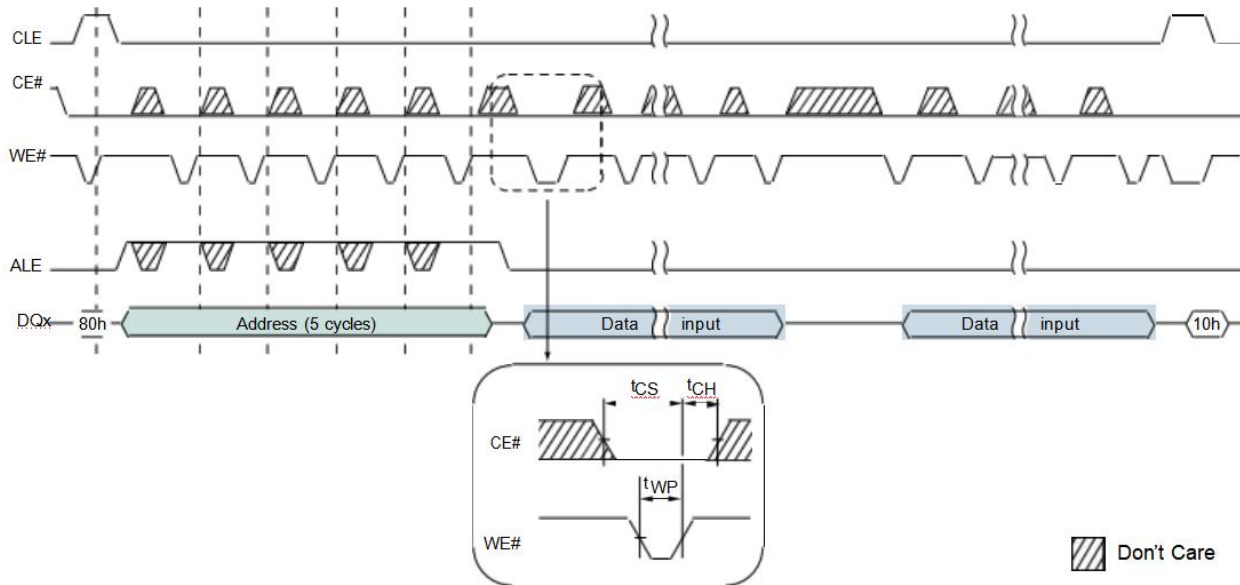


Figure 80: PROGRAM PAGE Operation with CHANGE WRITE COLUMN

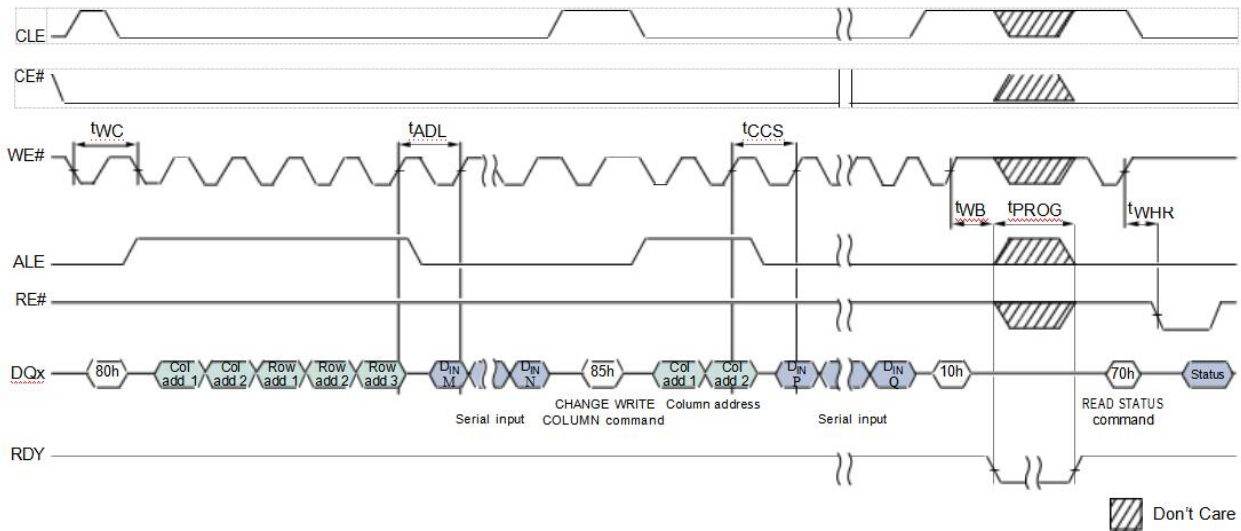


Figure 81: PROGRAM PAGE CACHE

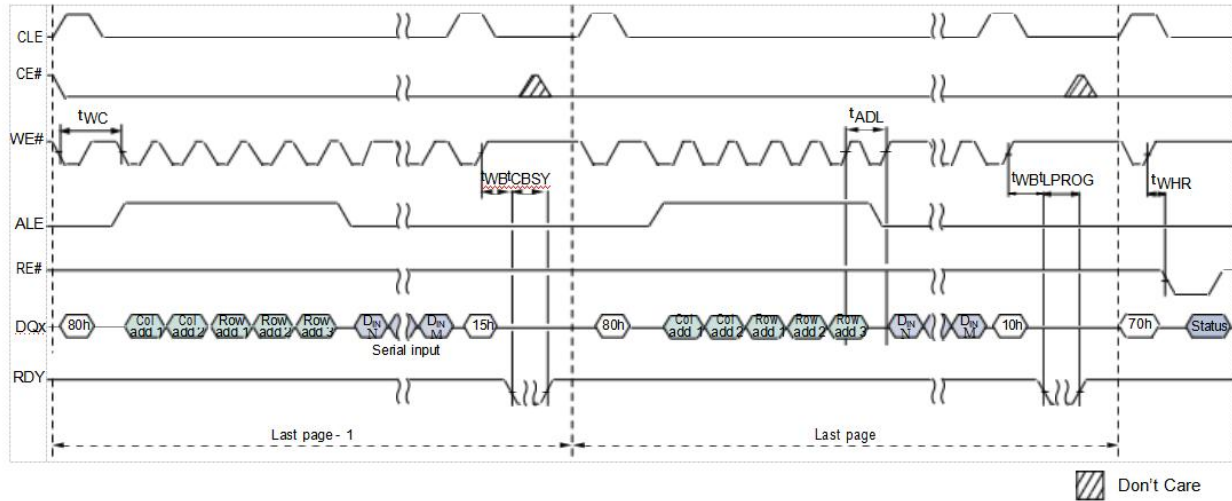


Figure 82: PROGRAM PAGE CACHE Ending on 15h

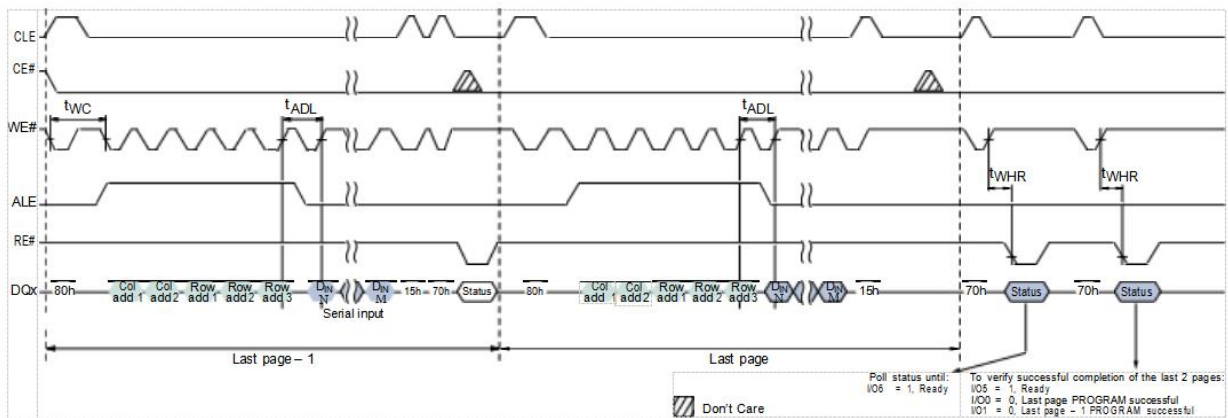


Figure 83: COPYBACK

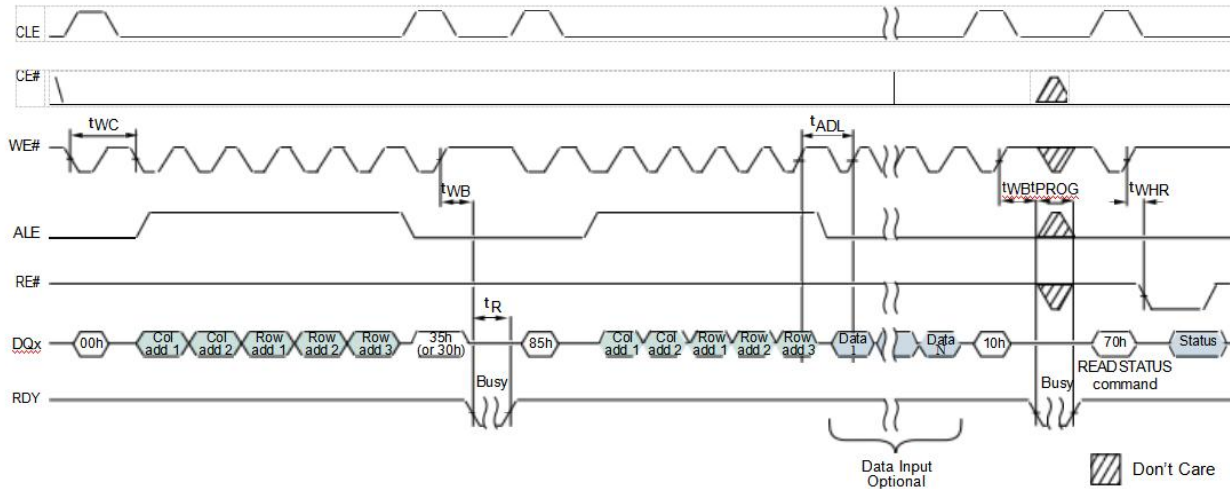
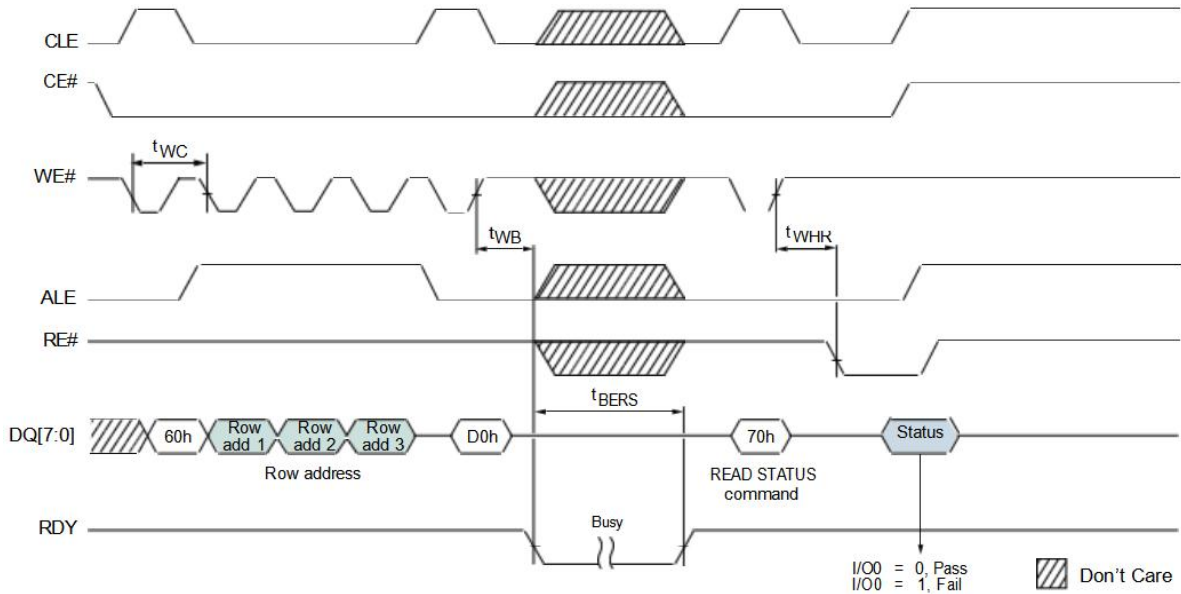
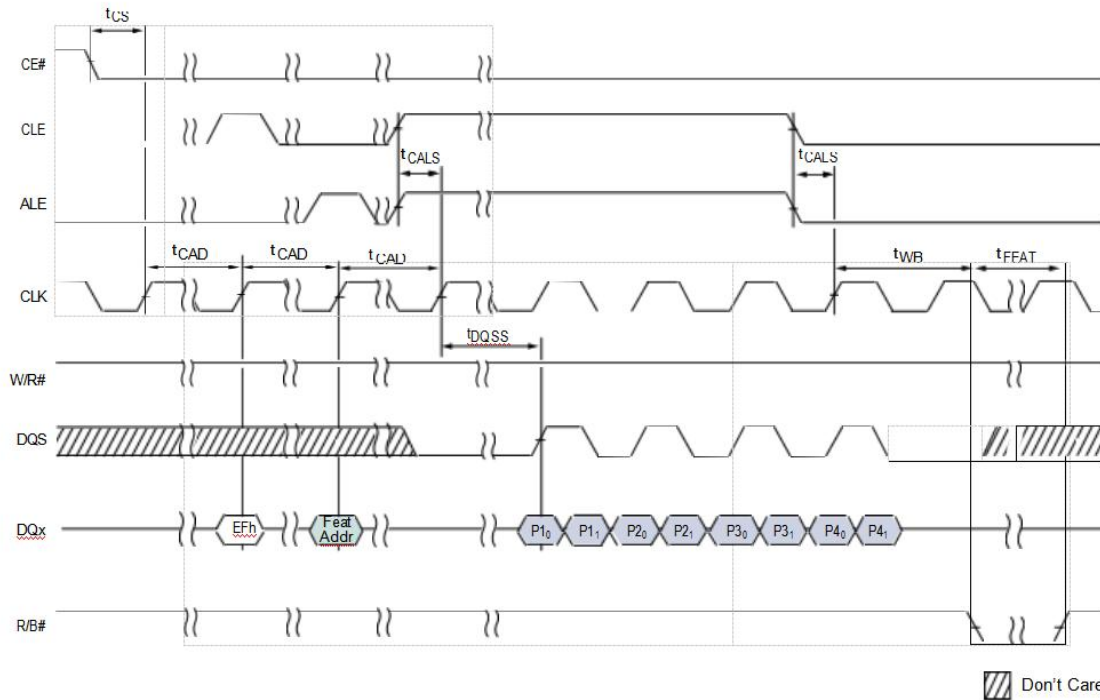


Figure 84: ERASE BLOCK Operation



42 Synchronous Interface Timing Diagrams

Figure 85: SET FEATURES Operation



Notes:

1. When CE# remains LOW, t_{CAD} begins at the rising edge of the clock from which the last data byte is input for the subsequent command or data input cycle(s).
2. t_{DSH} (MIN) generally occurs during t_{DQSS} (MIN).
3. t_{DSS} (MIN) generally occurs during t_{DQSS} (MAX).
4. The cycle that t_{CAD} is measured from may be an idle cycle (as shown), another command cycle, an address cycle, or a data cycle. The idle cycle is shown in this diagram for simplicity.

Figure 86: READ ID Operation

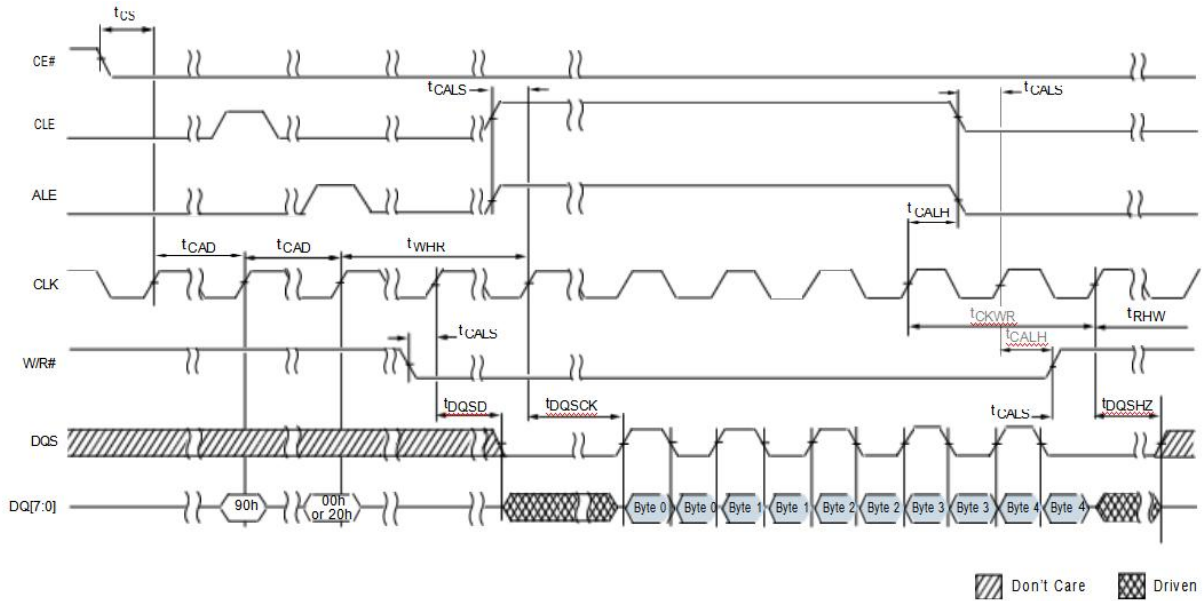


Figure 87: GET FEATURES Operation

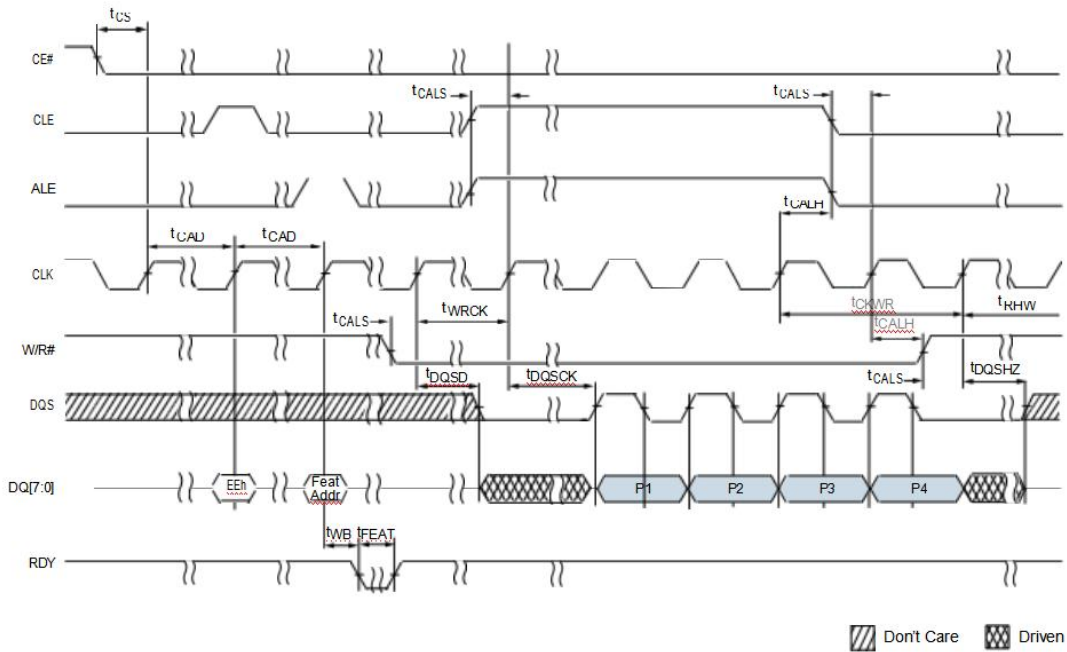


Figure 88: RESET (FCh) Operation

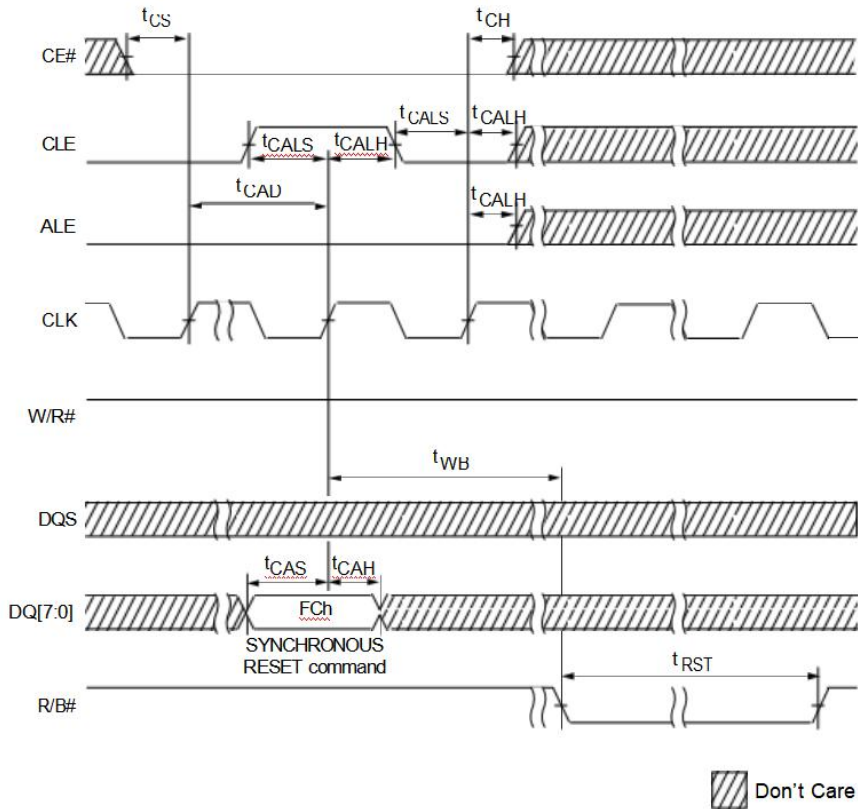


Figure 89: READ STATUS Cycle

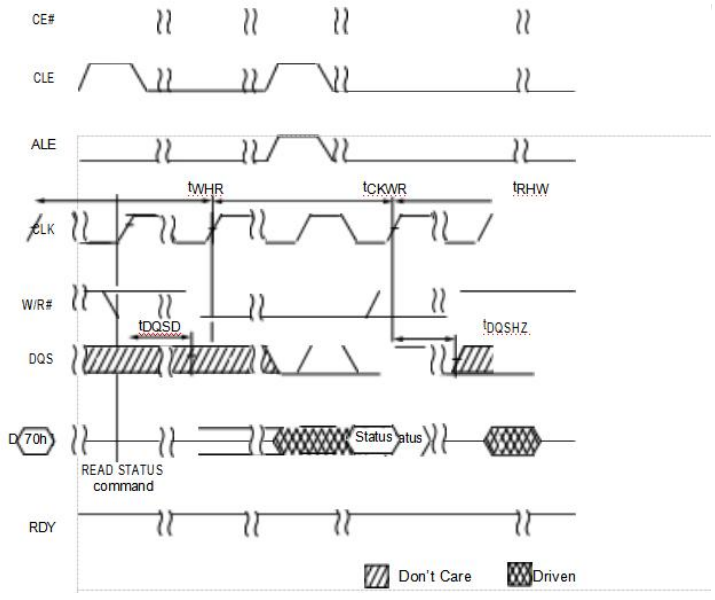


Figure 90: READ STATUS ENHANCED Operation

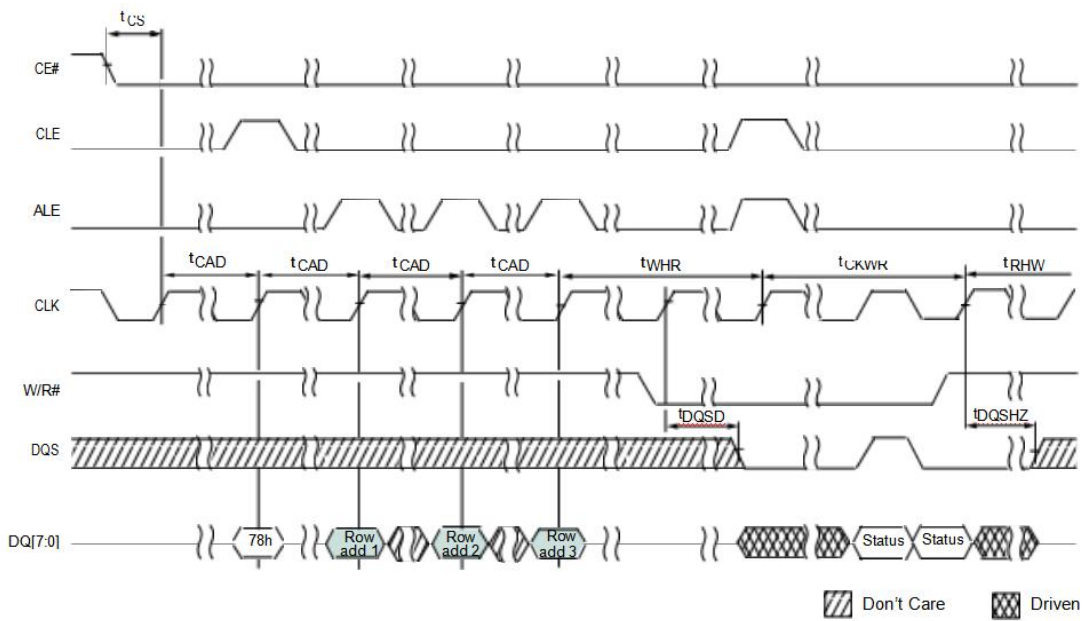


Figure 91: READ PARAMETER PAGE Operation

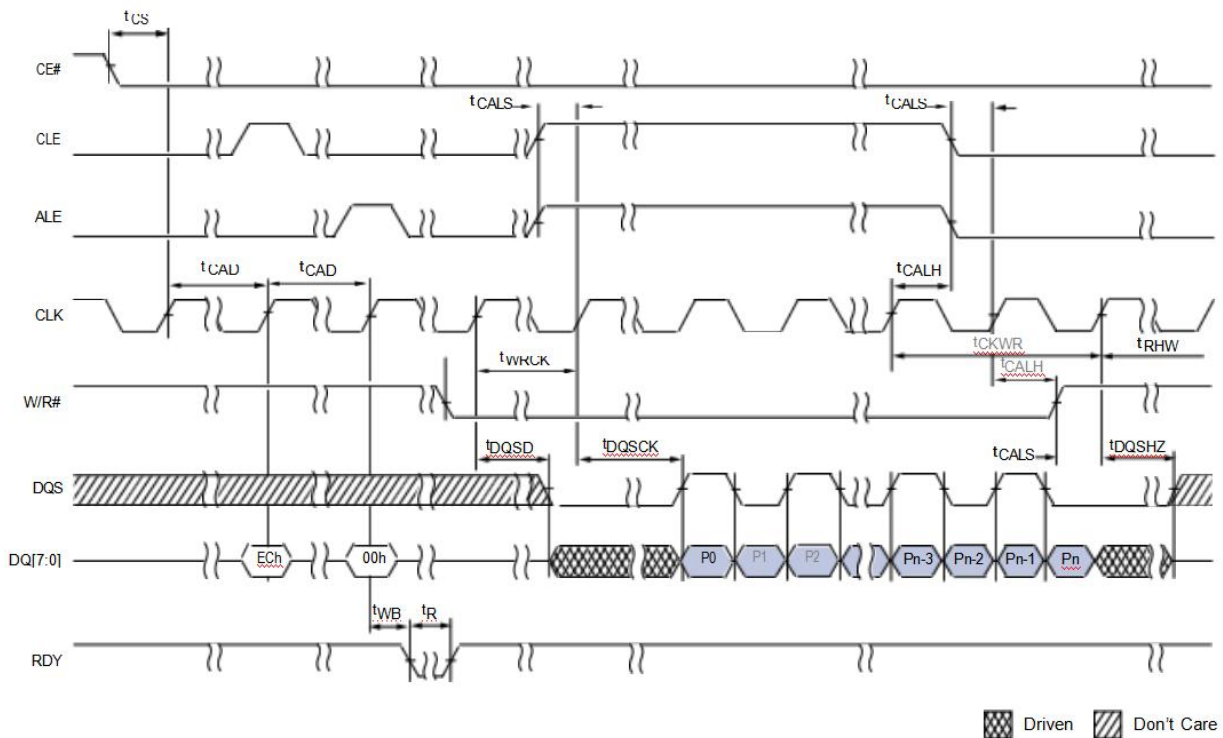


Figure 92: READ PAGE Operation

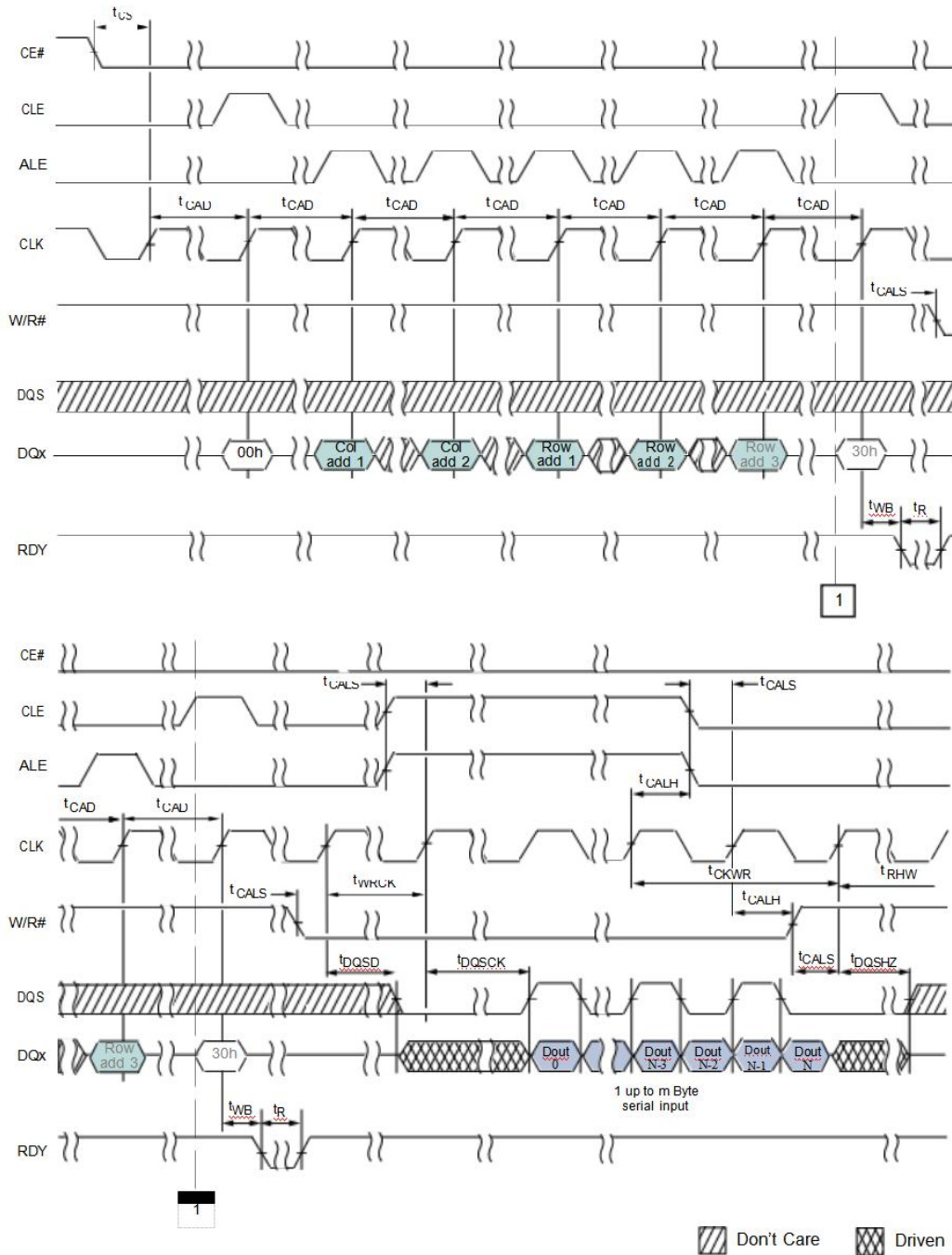


Figure 93: CHANGE READ COLUMN

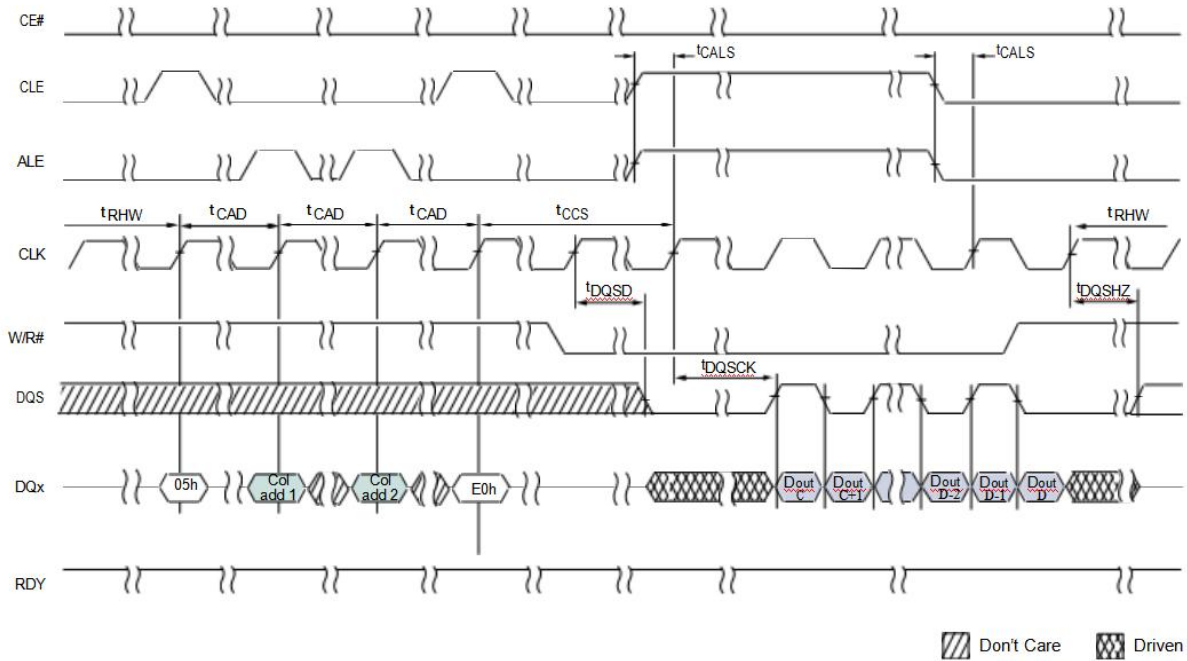


Figure 94: READ PAGE CACHE SEQUENTIAL (1 of 2)

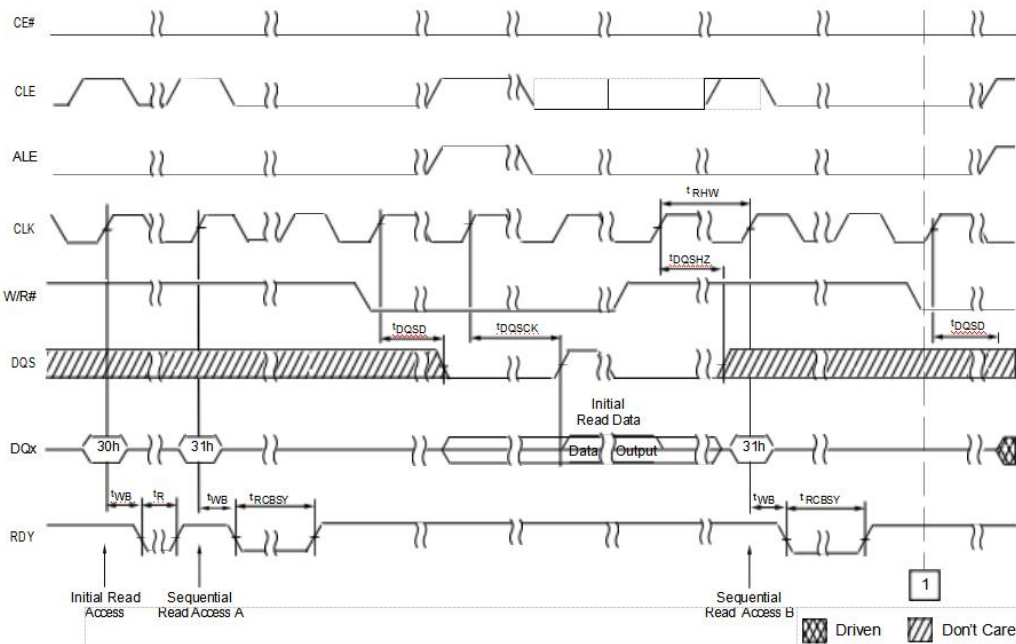


Figure 95: READ PAGE CACHE SEQUENTIAL (2 of 2)

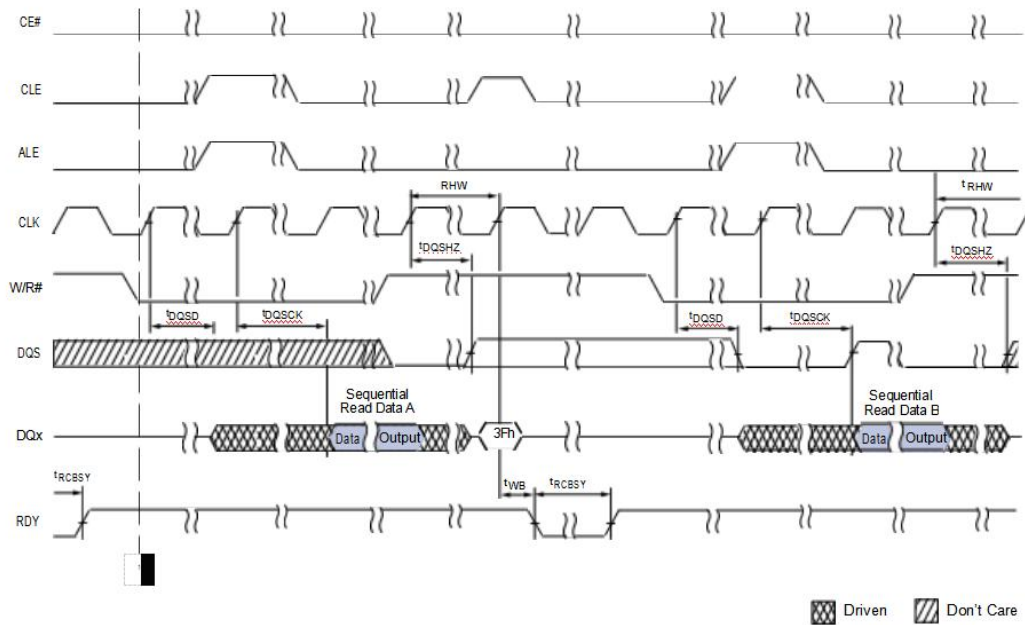


Figure 96: READ PAGE CACHE RANDOM (1 of 2)

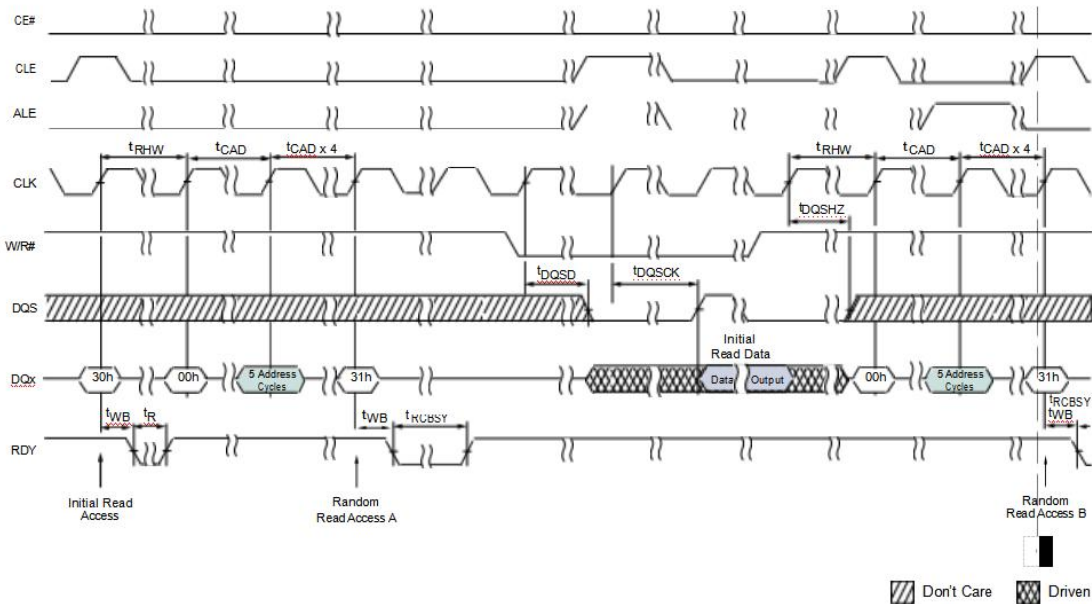


Figure 97: READ PAGE CACHE RANDOM (2 of 2)

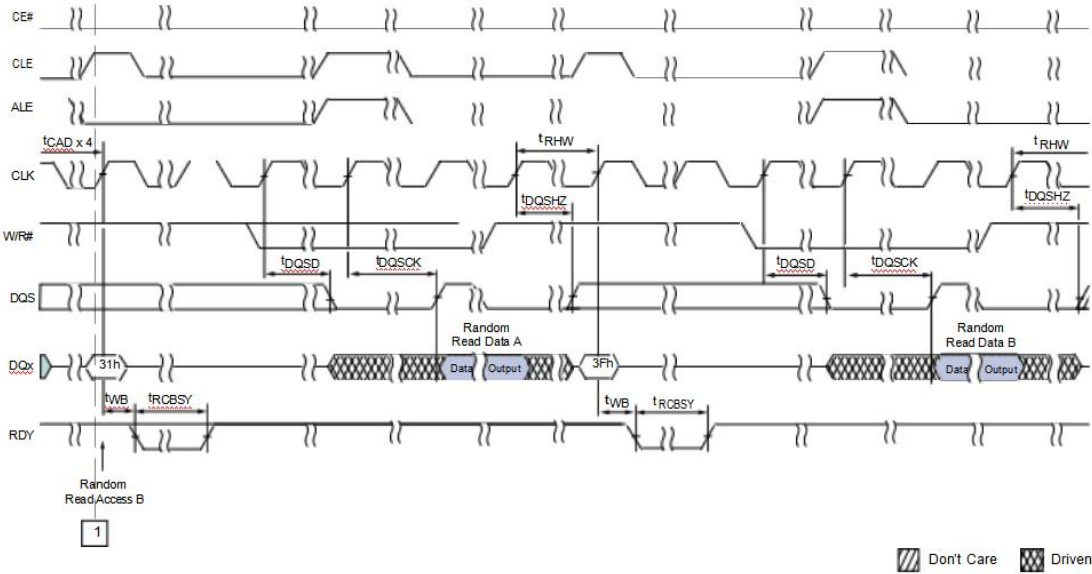


Figure 98: Multi-Plane Read Page (1 of 2)

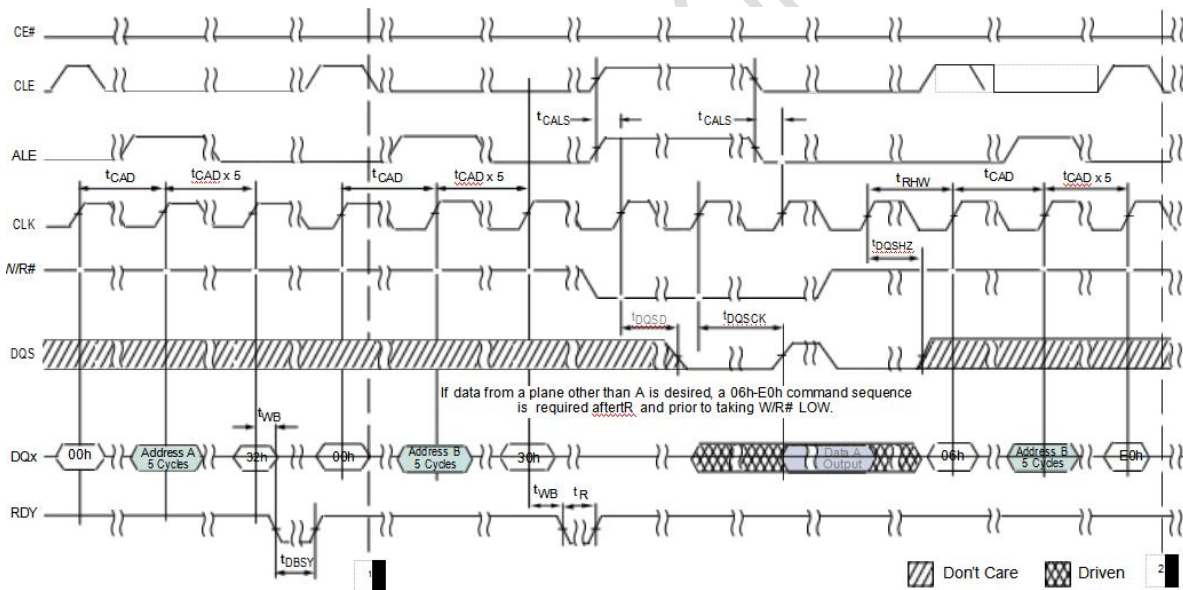


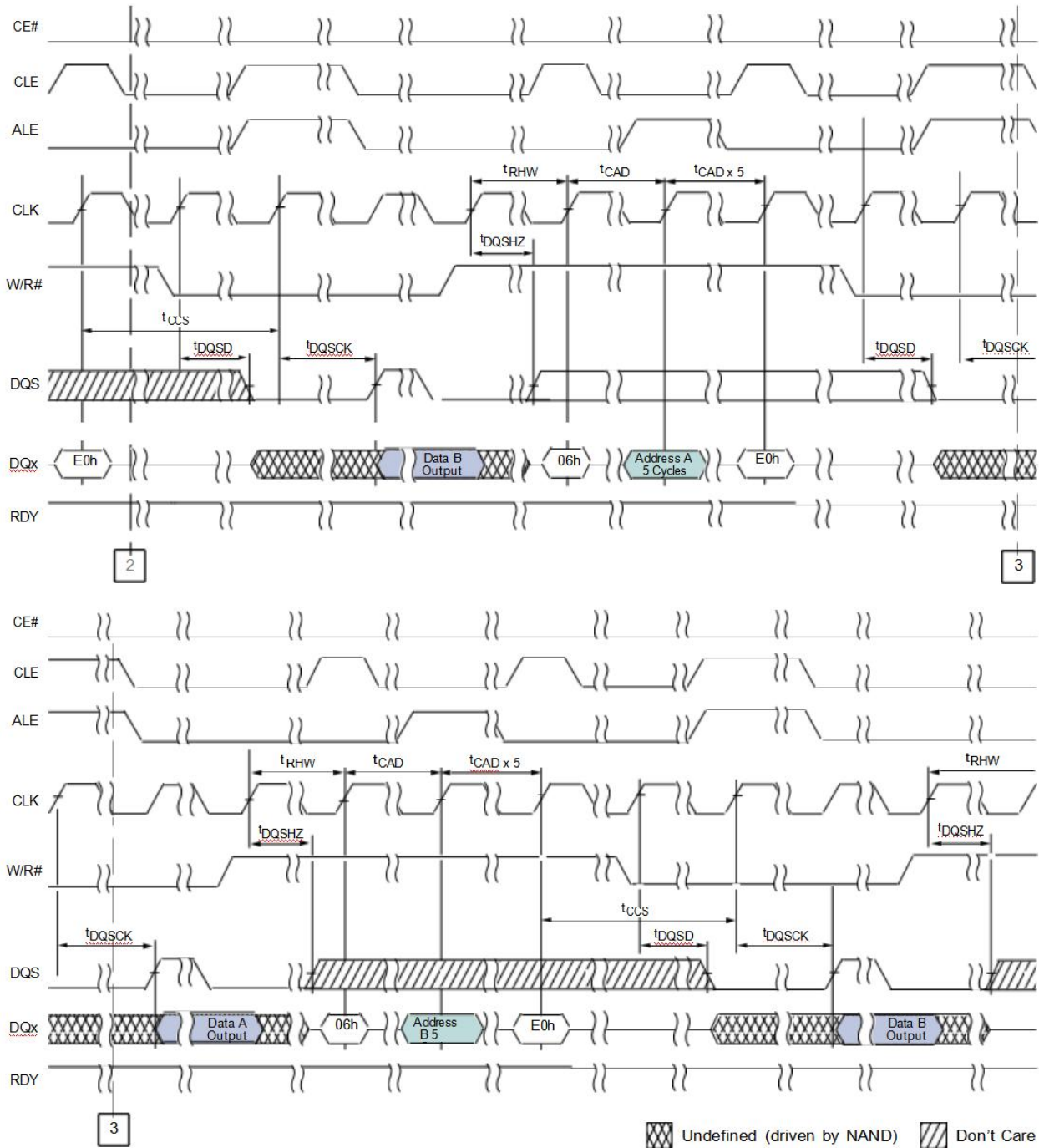
Figure 99: Multi-Plane Read Page (2 of 2)


Figure 100: PROGRAM PAGE Operation (1 of 2)

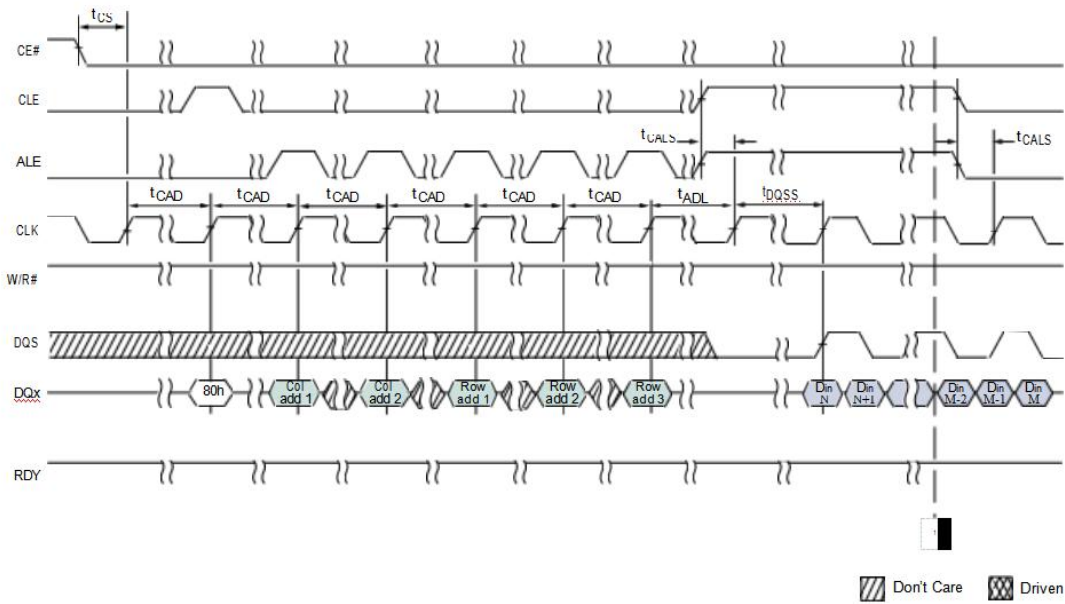


Figure 101: PROGRAM PAGE Operation (2 of 2)

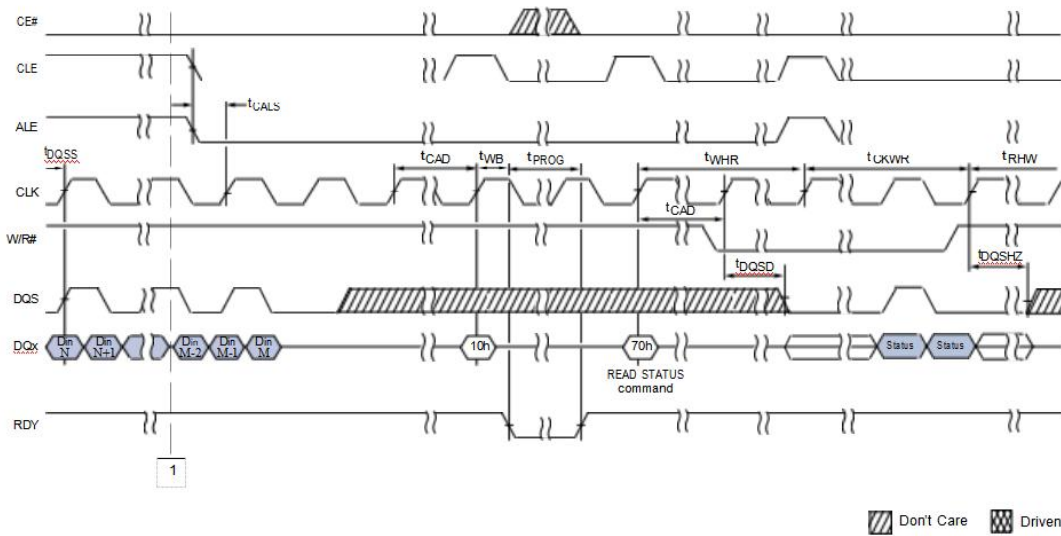


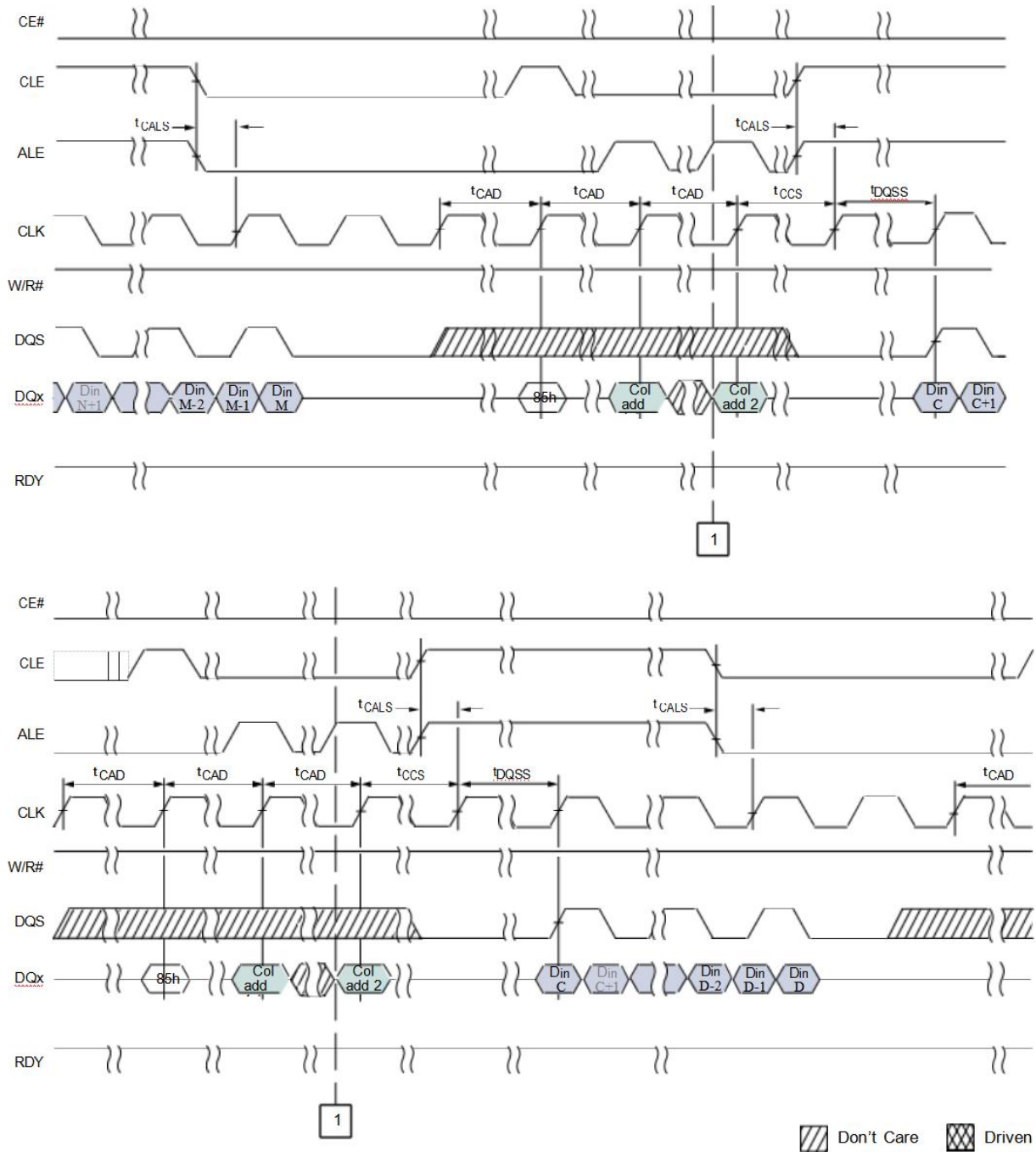
Figure 102: CHANGE WRITE COLUMN


Figure 103: Multi-Plane Program Page

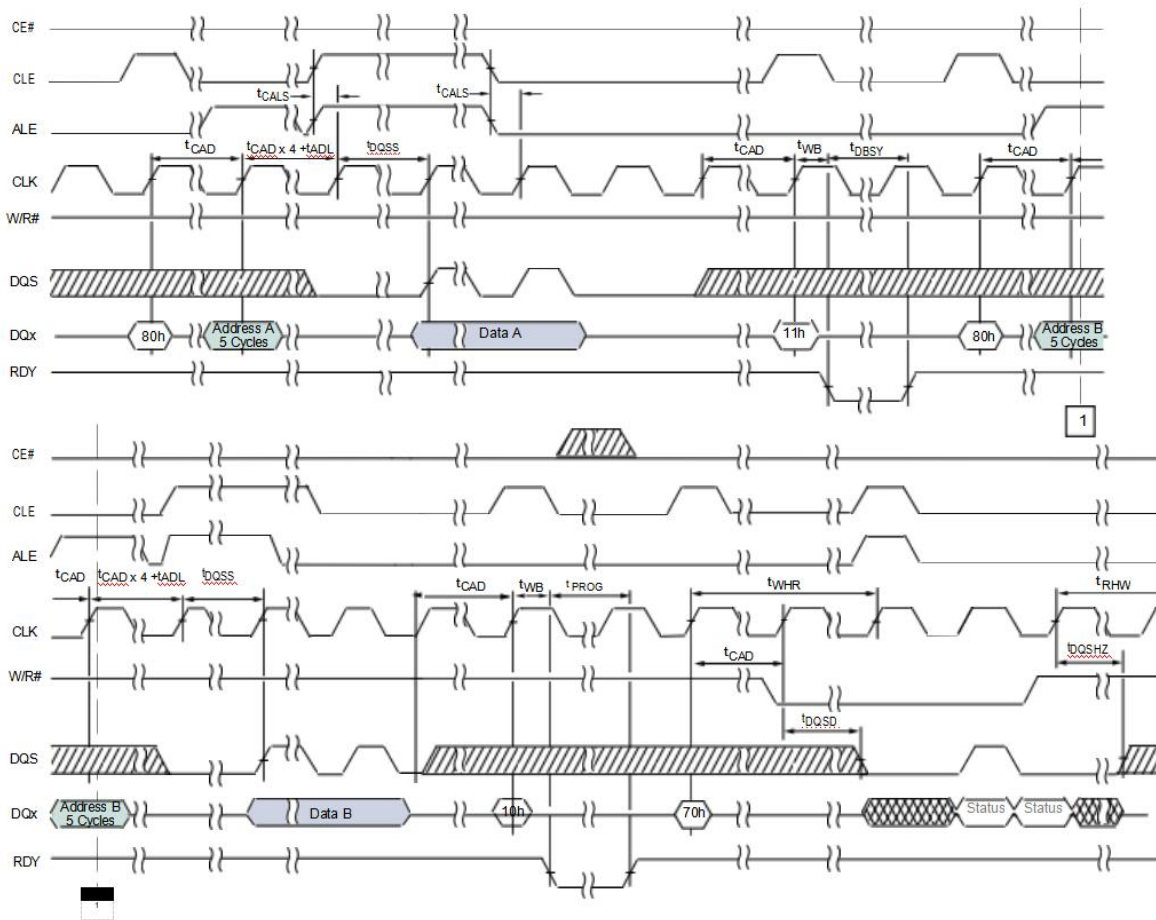
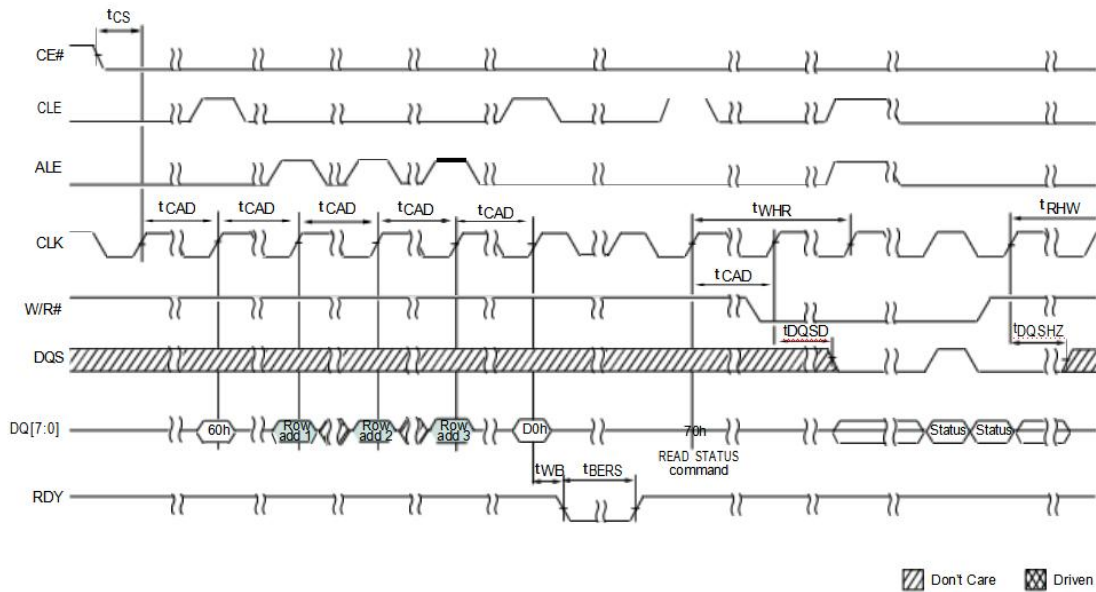


Figure 104: ERASE BLOCK



▨ Don't Care ▩ Driven

Figure 105: COPYBACK (1 of 3)

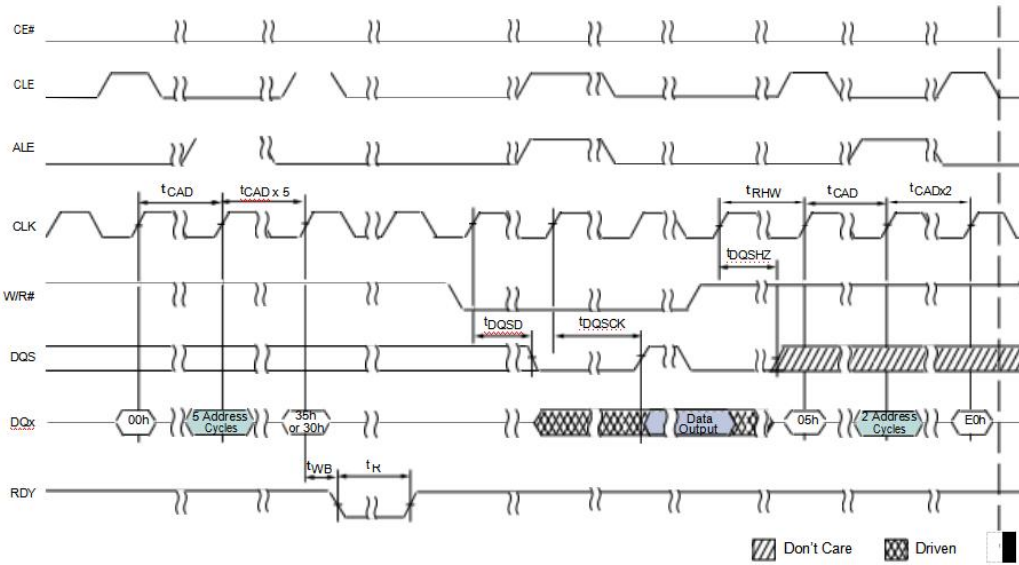


Figure 106: COPYBACK (2 of 3)

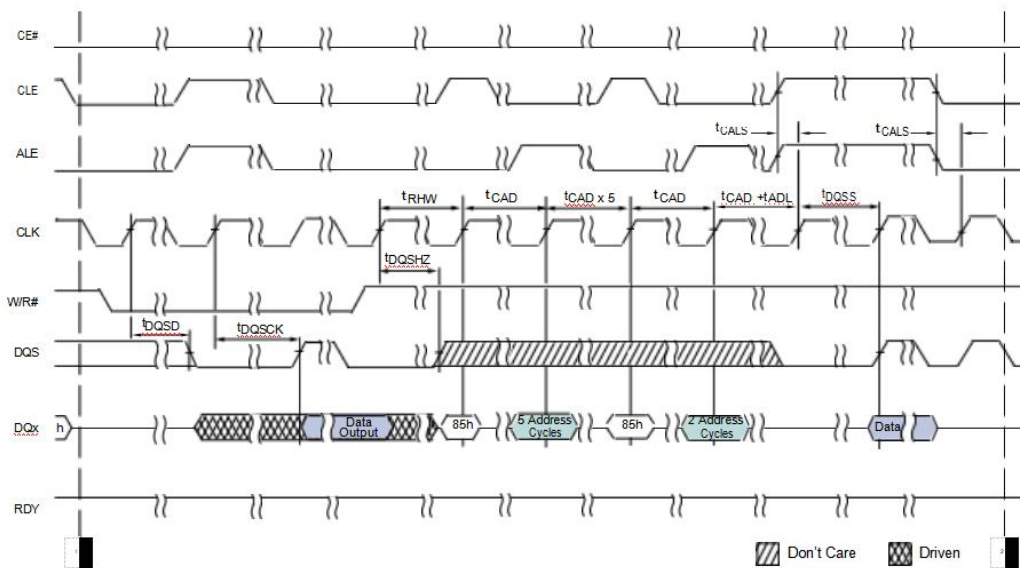


Figure 107: COPYBACK (3 of 3)

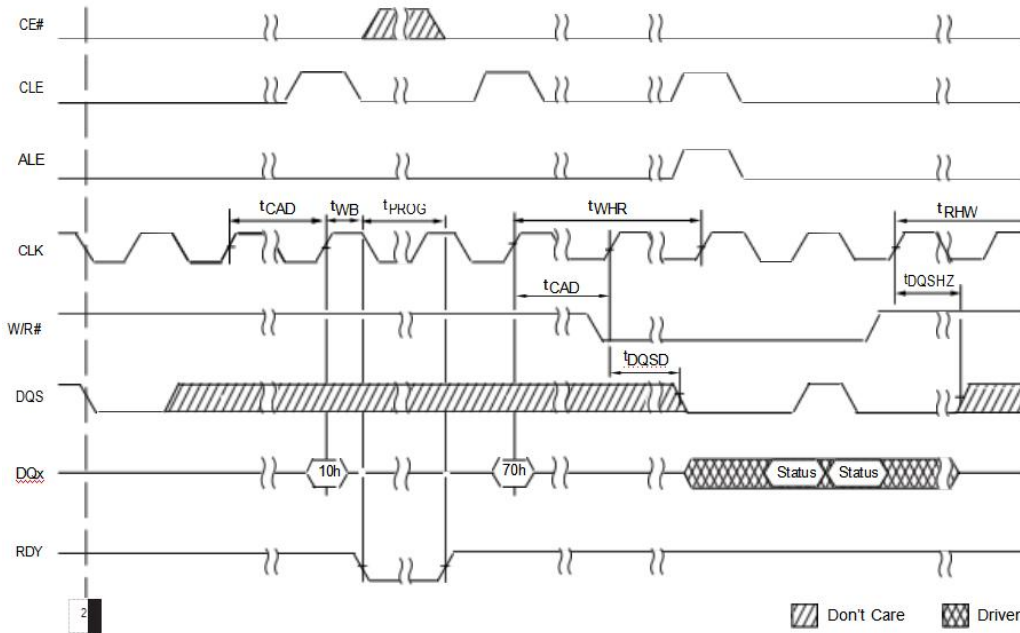


Figure 108: READ OTP PAGE

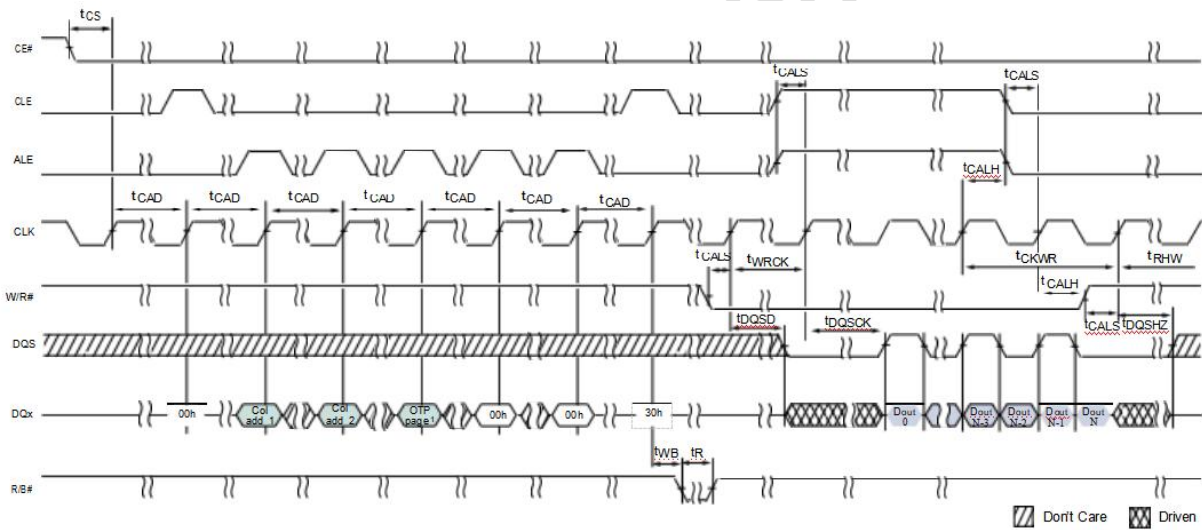


Figure 109: PROGRAM OTP PAGE (1 of 2)

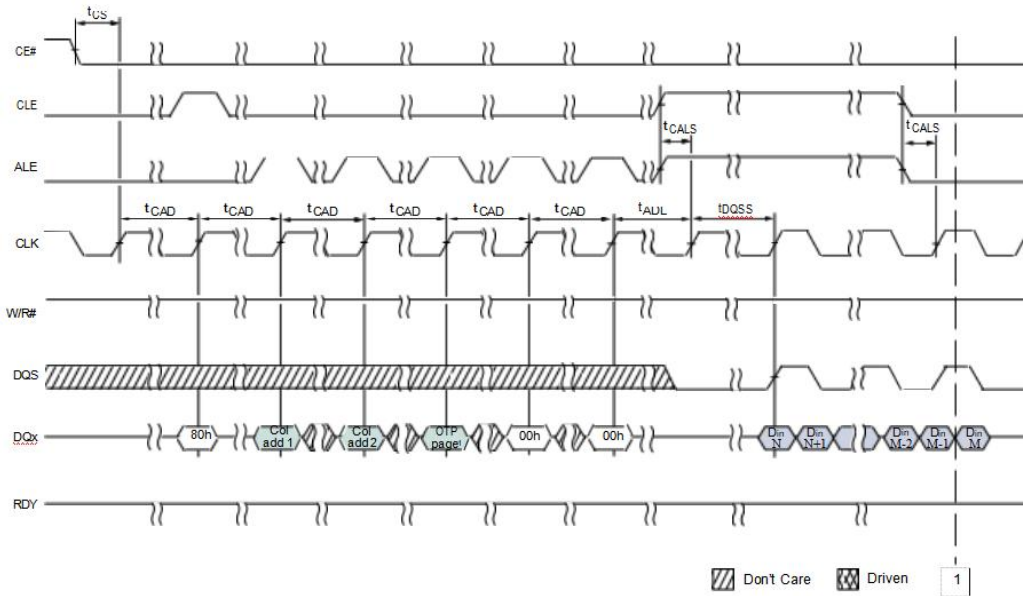


Figure 110: PROGRAM OTP PAGE (2 of 2)

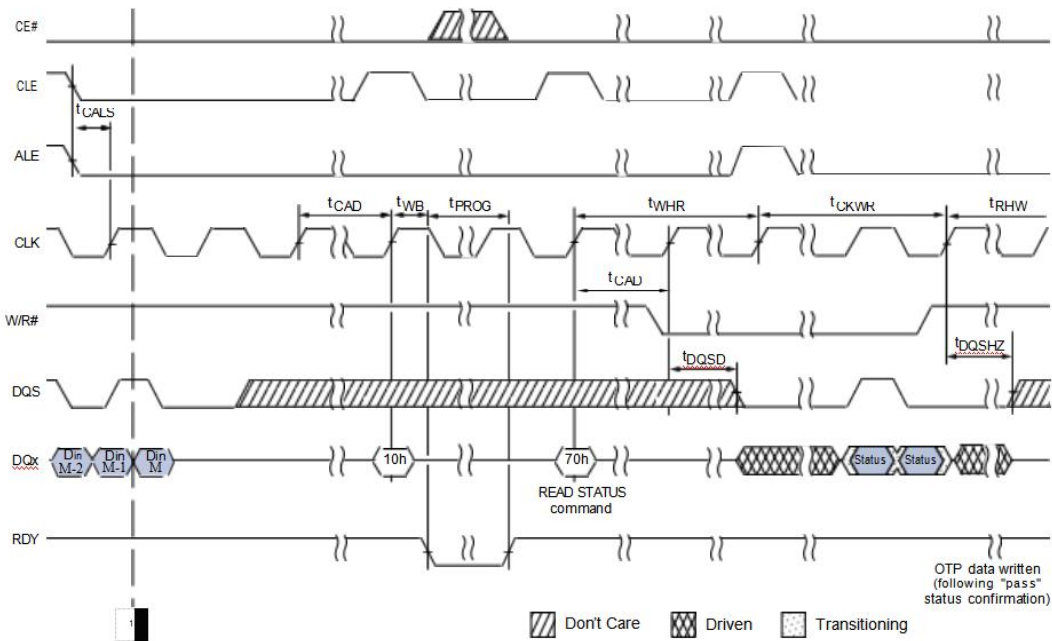


Figure 111: PROTECT OTP AREA

