

## Plug-in Signal Conditioners K-UNIT

### WATT TRANSDUCER

(for 3-phase / 4-wire, self-powered)

#### Functions & Features

- Providing a DC output signal in proportion to AC active power
- Pulse totalizer output
- Measuring bidirectional power flow
- DC output containing little ripple is ideal for computer input
- "Time division multiplication" method accepts distorted waveforms
- Isolation up to 2000 V AC
- High-density mounting

#### Typical Applications

- Centralized monitoring and control of power management system in a manufacturing facility or building
- SCR - Silicon Controlled Rectifier

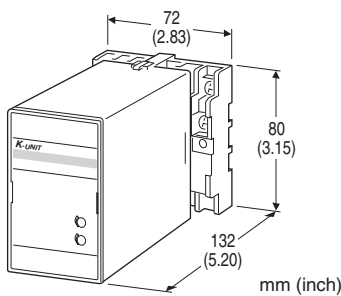

## MODEL: KUWEN-4[1][2][3][4]

### ORDERING INFORMATION

- Code number: KUWEN-4[1][2][3][4]
- Specify a code from below for each of [1] through [4].  
(e.g. KUWEN-41A0/Q)
- Calibration range (e.g. 0 - 980W)
- VT ratio, CT ratio (e.g. VT 3300 / 110 V, CT 250 / 5 A)
- Special DC output range (For codes Z & 0)
- Specify the specification for option code /Q  
(e.g. /C01/S01)

### CONFIGURATION

4: 3-phase / 4-wire

#### [1] INPUT (unbalanced load)

- 1: 63.5 V / 110 V / 5 A AC
- 2: 63.5 V / 110 V / 1 A AC
- 3: 127 V / 220 V / 1 A AC

- 4: 127 V / 220 V / 5 A AC
- 5: 220 V / 380 V / 1 A AC
- 6: 220 V / 380 V / 5 A AC
- 7: 110 V / 190 V / 1 A AC
- 8: 110 V / 190 V / 5 A AC

#### [2] DC OUTPUT

##### Current

- A: 4 - 20 mA DC (Load resistance 600 Ω max.)
- B: 2 - 10 mA DC (Load resistance 1200 Ω max.)
- C: 1 - 5 mA DC (Load resistance 2400 Ω max.)
- D: 0 - 20 mA DC (Load resistance 600 Ω max.)
- E: 0 - 16 mA DC (Load resistance 750 Ω max.)
- F: 0 - 10 mA DC (Load resistance 1200 Ω max.)
- G: 0 - 1 mA DC (Load resistance 12 kΩ max.)
- J: 0 - 5 mA DC (Load resistance 2400 Ω max.)
- GW: -1 - +1 mA DC (Load resistance 10 kΩ max.)
- Z: Specify current (See OUTPUT SPECIFICATIONS)

##### Voltage

- 1: 0 - 10 mV DC (Load resistance 10 kΩ min.)
- 2: 0 - 100 mV DC (Load resistance 100 kΩ min.)
- 3: 0 - 1 V DC (Load resistance 1000 Ω min.)
- 4: 0 - 10 V DC (Load resistance 10 kΩ min.)
- 5: 0 - 5 V DC (Load resistance 5000 Ω min.)
- 6: 1 - 5 V DC (Load resistance 5000 Ω min.)
- 1W: -10 - +10 mV DC (Load resistance 10 kΩ min.)
- 2W: -100 - +100 mV DC (Load resistance 100 kΩ min.)
- 3W: -1 - +1 V DC (Load resistance 1000 Ω min.)
- 4W: -10 - +10 V DC (Load resistance 10 kΩ min.)
- 5W: -5 - +5 V DC (Load resistance 5000 Ω min.)
- 0: Specify voltage (See OUTPUT SPECIFICATIONS)

#### [3] PULSE OUTPUT

- 0: None
- 1: Open collector

#### [4] OPTIONS

- blank: none
- /Q: With options (specify the specification)

#### SPECIFICATIONS OF OPTION: Q (multiple selections)

##### COATING (For the detail, refer to M-System's web site.)

- /C01: Silicone coating
- /C02: Polyurethane coating
- /C03: Rubber coating

##### TERMINAL SCREW MATERIAL

- /S01: Stainless steel

## GENERAL SPECIFICATIONS

- Construction:** Plug-in  
**Connection:** M3.5 screw terminals  
**Screw terminal:** Chromated steel (standard) or stainless steel  
**Housing material:** Flame-resistant resin (black)  
**Isolation:** Voltage input to current input to DC output to pulse output  
**Computation:** Time division multiplication  
**Overrange output:** Approx. -10 to +120 % at 1 - 5 V  
**Zero adjustment(DC output):** -5 to + 5 % (front)  
**Span adjustment(DC output):** 95 to + 105 % (front)

## INPUT SPECIFICATIONS

- Frequency:** 50 or 60 Hz
- Voltage Input**  
**Operational range:** 85 - 110 % of rating  
**Overload capacity:** 150 % of rating for 10 sec., 110 % continuous
  - Current Input**  
**Operational range:** 0 - 120 % of rating  
**Overload capacity:** 1000 % of rating for 3 sec., 200 % for 10 sec., 120 % continuous

### How To Determine Wattage Range

Calibration Range [W] = (Measuring Wattage) ÷ ((VT Ratio) × (CT Ratio))

Check that the required calibration range is within the available range in the table.

[example]

3-phase / 4-wire, measuring wattage 75 kW,

VT 127 / 127 V, CT 250 / 5 A

$(75 \times 10^3 [W]) \div ((127 \div 127) \times (250 \div 5)) = 1500 [W]$

### INPUT RANGE

#### 3-phase / 4-wire

INPUT	STD.RANGE	AVAILABLE RANGE	BURDEN (VA)	
			VOLT.	CURR.
$\frac{110V}{\sqrt{3}}/1A$	±200 W	±100 - ±240 W	P <sub>1</sub> -P <sub>2</sub> : 2.5	0.1 /phase
$\frac{110V}{\sqrt{3}}/5A$	±1000 W	±500 - ±1200 W	P <sub>3</sub> : 0.1	0.5 /phase
$\frac{190V}{\sqrt{3}}/1A$	±350 W	±175 - ±420 W	P <sub>1</sub> : 2.5	0.1 /phase
$\frac{190V}{\sqrt{3}}/5A$	±1750 W	±875 - ±2100 W	P <sub>2</sub> , P <sub>3</sub> : 0.2	0.5 /phase
$\frac{220V}{\sqrt{3}}/1A$	±400 W	±200 - ±480 W	P <sub>1</sub> -P <sub>2</sub> : 2.5	0.1 /phase
$\frac{220V}{\sqrt{3}}/5A$	±2000 W	±1000 - ±2400 W	P <sub>3</sub> : 0.3	0.5 /phase
$\frac{380V}{\sqrt{3}}/1A$	±700 W	±350 - ±840 W	P <sub>1</sub> : 2.5	0.1 /phase
$\frac{380V}{\sqrt{3}}/5A$	±3500 W	±1750 - ±4200 W	P <sub>2</sub> , P <sub>3</sub> : 0.4	0.5 /phase

## OUTPUT SPECIFICATIONS

### DC OUTPUT

- DC Current:** 0 - 20 mA DC and ± 1 mA

**Minimum span:** 1 mA

**Offset:** Max. 1.5 times span

**Load resistance:** Output drive 12 V max.

- DC Voltage:** -10 - +12 V DC

**Minimum span:** 5 mV

**Offset:** Max. 1.5 times span

**Load resistance:** Output drive 1 mA max. at ≥ 0.5 V

- Pulse Output:** Open collector; 0 Hz at 0 W

(Cutout at approx. 0.5 - 1.0 %)

**Rating:** 35 V DC @ 100 mA

**ON voltage:** ≤ 1 V at 100 mA

**ON duration:** max. 0.5 sec., min. 50 msec.

**Frequency range:** 2.777 Hz (at 100 %)

[Example] 1000 W calibration range

$2.777 [Hz] \times 3600 [sec.] \div 1 [kW] = 10000 [pulse/kWh]$

### OPERATION DIAGRAM (example)

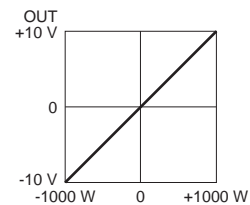
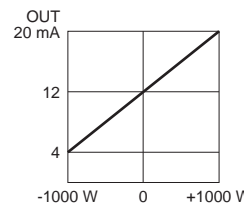
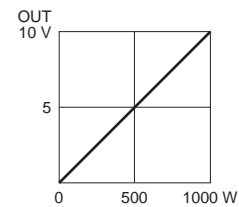
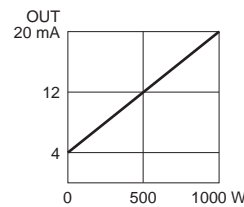

## INSTALLATION

**Operating temperature:** -10 to +55°C (14 to 131°F)

**Operating humidity:** 30 to 85 %RH (non-condensing)

**Mounting:** Surface or DIN rail

**Weight:** 500 g (1.1 lb)

## PERFORMANCE in percentage of span

**Accuracy:** ±0.5 % (at 23°C ±10°C or 73.4°F ±18°F, 45 - 65 Hz)

**Response time:** ≤ 2 sec. (0 - 100 % ±1 %)

**Ripple:** 0.5 %p-p max.

**Insulation resistance:** ≥ 100 MΩ with 500 V DC

**Dielectric strength:** 2000 V AC @ 1 minute

(voltage input to current input to DC output to pulse output to ground)

**Impulse withstand voltage:** 1.2 / 50 μsec., ±5 kV

(input to output or ground)

## CONNECTION DIAGRAM

### ■ 3-PHASE/4-WIRE

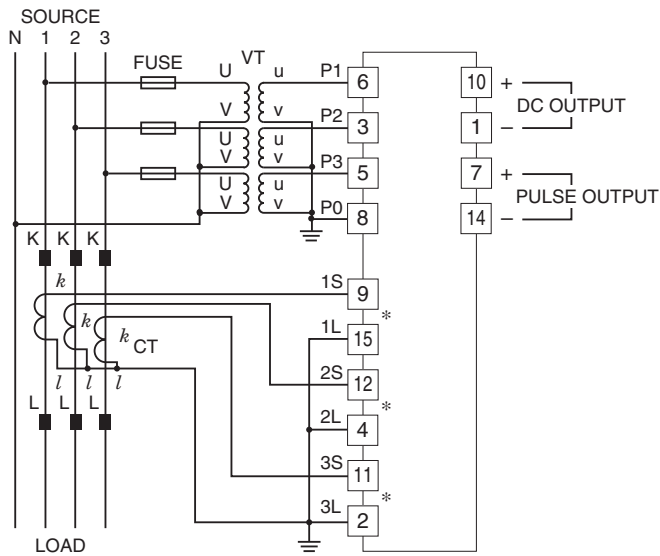

\*CT Protector (model: CTM) attached to these terminals.

#### Pulse Output Connection Example

##### ■ Open Collector

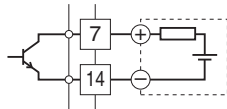

## EXTERNAL DIMENSIONS unit: mm (inch)

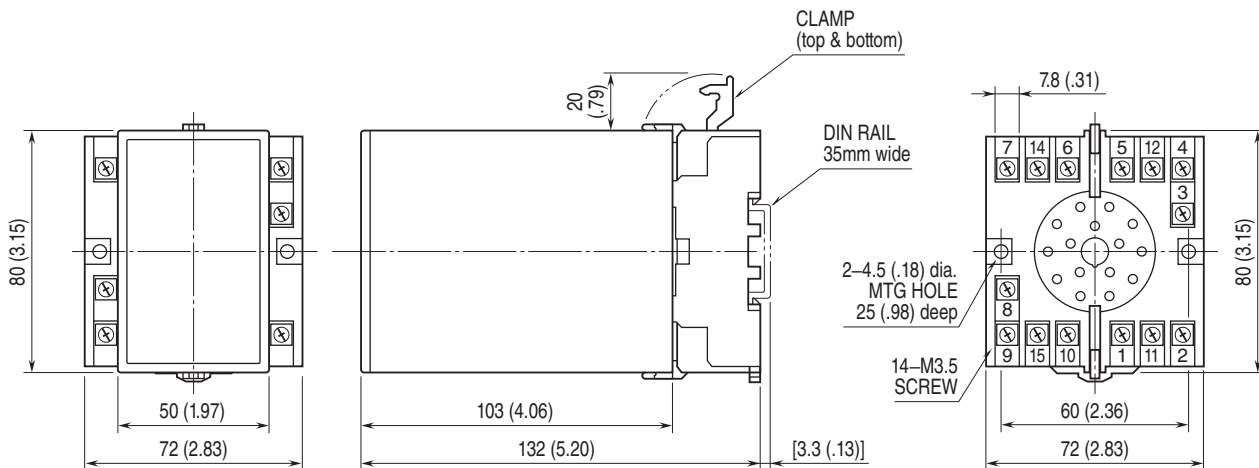

• When mounting, no extra space is needed between units.

**TERMINAL ASSIGNMENTS unit: mm (inch)**

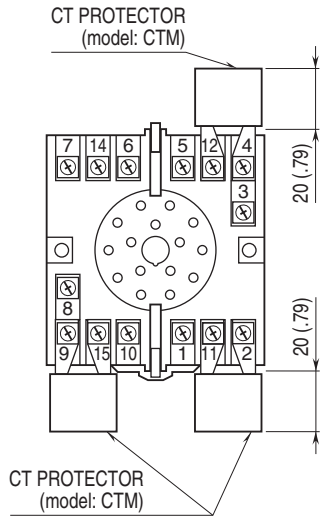

Specifications are subject to change without notice.