

NHD-C0216CiZ-FSW-FBW-3V3

COG (Chip-on-Glass) Liquid Crystal Display Module

NHD- Newhaven Display
C0216- COG, 2 Lines x 16 Characters
CiZ- Model
F- Transflective
SW- Side White LED Backlight
F- FSTN (+)
B- 6:00 Optimal View
W- Wide Temp
3V3- 3.0V LCD, 3.0V Backlight
RoHS Compliant

Newhaven Display International, Inc.

2661 Galvin Ct.

Elgin IL, 60124

Ph: 847-844-8795

Fax: 847-844-8796

www.newhavendisplay.com

nhtech@newhavendisplay.com

nhsales@newhavendisplay.com

Document Revision History

Revision	Date	Description	Changed by
0	3/10/00	Initial Release	-
1	5/14/09	User guide reformat	BE
2	10/9/09	Updated Electrical Characteristic Information	MC
3	11/5/09	Block Diagram Update	BE
4	11/19/09	Updated backlight current	MC
5	2/12/10	Updated Font table	MC
6	4/18/11	Mechanical drawing updated	AK
7	8/26/11	Mechanical drawing updated	TJ
8	11/29/11	Mechanical drawing updated	AK
9	3/30/12	Example initialization program updated	AK
10	7/22/14	User guide reformat	ML
11	4/28/16	Mechanical drawing, Electrical characteristics, Optical characteristics updated	SB
12	6/7/16	Added Pin Numbers to Mechanical Drawing	SB
13	12/1/16	Wiring Diagram & Electrical Characteristics Updated	SB
14	5/18/17	Backlight Characteristics Updated	SB

Functions and Features

- 2 lines x 16 characters
- Built-in ST7032i-oD with I²C interface
- 5x8 pixels with cursor
- 3V power supply
- 1/16 duty, 1/5 bias
- RoHS Compliant

Mechanical Drawing

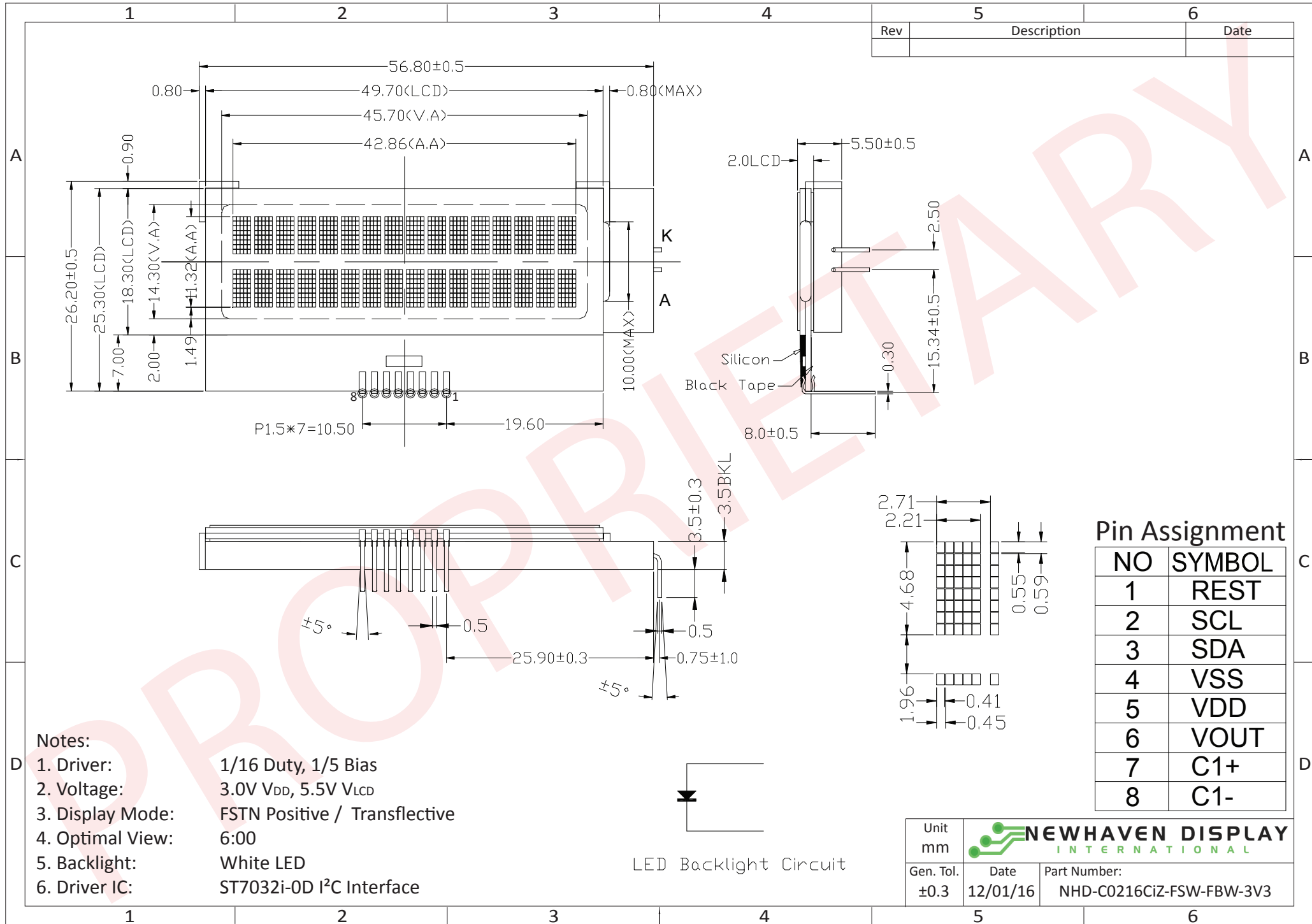

- Notes:**
1. Driver: 1/16 Duty, 1/5 Bias
 2. Voltage: 3.0V V_{DD}, 5.5V V_{LCD}
 3. Display Mode: FSTN Positive / Transflective
 4. Optimal View: 6:00
 5. Backlight: White LED
 6. Driver IC: ST7032i-0D I²C Interface

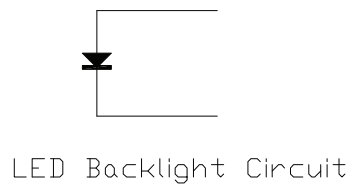

Pin Description and Wiring Diagram

Pin No.	Symbol	External Connection	Function Description
1	RST	MPU	Active LOW Reset signal
2	SCL	MPU	Serial Clock input
3	SDA	MPU	Serial Data input
4	V _{SS}	Power Supply	Ground
5	V _{DD}	Power Supply	Supply Voltage for LCD and Logic (3.0V)
6	VOUT	Power Supply	Connect to 0.47~2.2 μ F capacitor to V _{DD}
7	C1+	CAP	Connect to 0.1~1 μ F cap to PIN8
8	C1-	CAP	Connect to 0.1~1 μ F cap to PIN7
A	LED+	Power Supply	Backlight Anode (20 mA @ 3V)
K	LED-	Power Supply	Backlight Cathode (Ground)

Recommended LCD connector: 1.5mm pitch pins, solder directly to PCB

Backlight connector: A & K pins **Mates with:** -

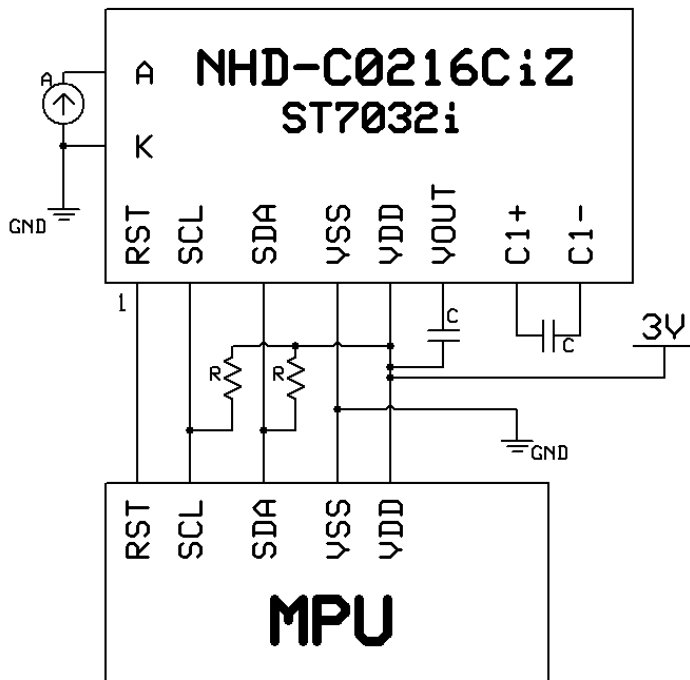

C = 1 μ F

R = 4.7k Ω – 10k Ω

Electrical Characteristics

Item	Symbol	Condition	Min.	Typ.	Max.	Unit
Operating Temperature Range	T_{OP}	Absolute Max	-20	-	+70	°C
Storage Temperature Range	T_{ST}	Absolute Max	-30	-	+80	°C
Supply Voltage	V_{DD}	-	2.7	3.0	3.3	V
Supply Current	I_{DD}	$V_{DD} = 3.0V$	100	300	500	μA
Supply for LCD (contrast)	V_{LCD}	$T_{OP} = 25^{\circ}C$	5.2	5.5	5.8	V
"H" Level input	V_{IH}	-	1.9	-	V_{DD}	V
"L" Level input	V_{IL}	-	V_{SS}	-	0.8	V
"H" Level output	V_{OH}	-	$0.75 * V_{DD}$	-	V_{DD}	V
"L" Level output	V_{OL}	-	V_{SS}	-	0.8	V
Backlight supply current	I_{LED}	-	-	20	30	mA
Backlight supply voltage	V_{LED}	$I_{LED} = 20\text{ mA}$	2.8	3.0	3.2	V

*The LED of the backlight is driven by current drain; drive voltage is for reference only. Drive voltage must be selected to ensure backlight current drain is below MAX level stated.

Optical Characteristics

Item	Symbol	Condition	Min.	Typ.	Max.	Unit
Optimal Viewing Angle	Top	$\phi Y+$	-	40	-	°
	Bottom	$\phi Y-$	-	60	-	°
	Left	$\theta X-$	-	60	-	°
	Right	$\theta X+$	-	60	-	°
Contrast Ratio	CR	-	2	5	-	-
Response Time	Rise	T_R	-	150	250	ms
	Fall	T_F	-	200	300	ms

Controller Information

Built-in ST7032i-0D controller.

Please download specification at http://www.newhavendisplay.com/app_notes/ST7032.pdf

Slave Address = 0x7C

Write mode

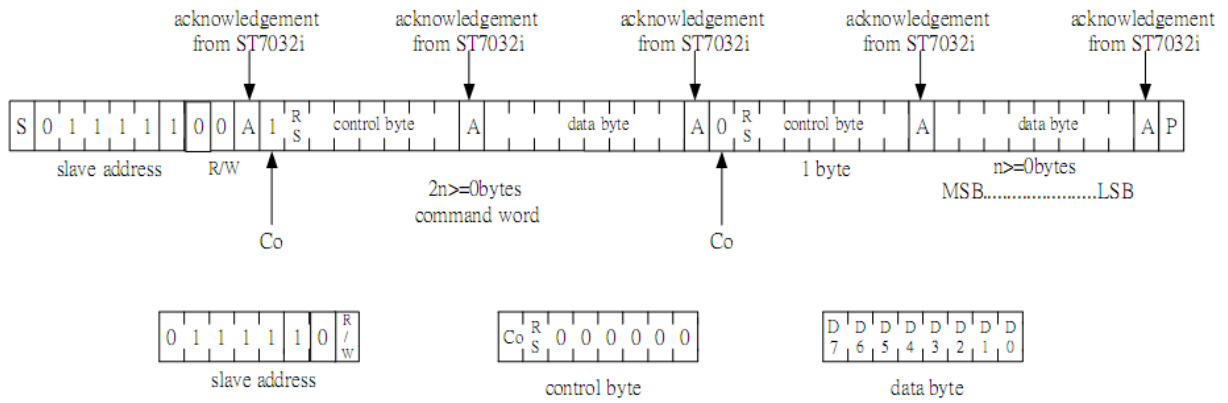
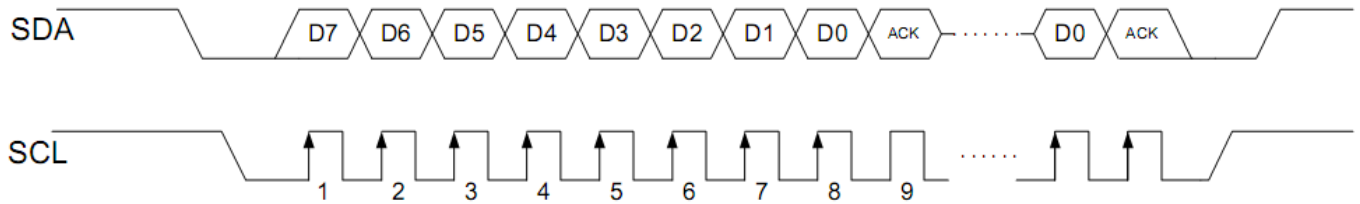

Figure 5. 2-line Interface protocol

Co	0	Last control byte to be sent. Only a stream of data bytes is allowed to follow. This stream may only be terminated by a STOP condition.
	1	Another control byte will follow the data byte unless a STOP condition is received.



Display Position	
	1 2 3 4 5 6 38 39 40
DDRAM Address (hexadecimal)	00 01 02 03 04 05 25 26 27
	40 41 42 43 44 45 65 66 67

Table of Commands

➤ instruction table at "Extension mode"

(when "EXT" option pin connect to VSS, the instruction set follow below table)

Instruction	Instruction Code										Description	Instruction Execution Time			
	RS	R/W	DB7	DB6	DB5	DB4	DB3	DB2	DB1	DB0		OSC=380KHz	OSC=540KHz	OSC=700KHz	
Clear Display	0	0	0	0	0	0	0	0	0	1	Write "20H" to DDRAM. and set DDRAM address to "00H" from AC	1.08 ms	0.76 ms	0.59 ms	
Return Home	0	0	0	0	0	0	0	0	0	1	x	Set DDRAM address to "00H" from AC and return cursor to its original position if shifted. The contents of DDRAM are not changed.	1.08 ms	0.76 ms	0.59 ms
Entry Mode Set	0	0	0	0	0	0	0	1	W/D	S		Sets cursor move direction and specifies display shift. These operations are performed during data write and read.	26.3 us	18.5 us	14.3 us
Display ON/OFF	0	0	0	0	0	0	1	D	C	B		D=1:entire display on C=1:cursor on B=1:cursor position on	26.3 us	18.5 us	14.3 us
Function Set	0	0	0	0	1	DL	N	DH	*0	IS		DL: interface data is 8/4 bits N: number of line is 2/1 DH: double height font IS: instruction table select	26.3 us	18.5 us	14.3 us
Set DDRAM address	0	0	1	AC6	AC5	AC4	AC3	AC2	AC1	AC0		Set DDRAM address in address counter	26.3 us	18.5 us	14.3 us
Write data to RAM	1	0	D7	D6	D5	D4	D3	D2	D1	D0		Write data into internal RAM (DDRAM/CGRAM/ICONRAM)	26.3 us	18.5 us	14.3 us

Instruction table 0 (IS=0)

Cursor or Display Shift	0	0	0	0	0	1	S/C	R/L	x	x		S/C and R/L: Set cursor moving and display shift control bit, and the direction, without changing DDRAM data.	26.3 us	18.5 us	14.3 us
Set CGRAM	0	0	0	1	AC5	AC4	AC3	AC2	AC1	AC0		Set CGRAM address in address counter	26.3 us	18.5 us	14.3 us

Instruction table 1 (IS=1)

Internal OSC frequency	0	0	0	0	0	1	BS	F2	F1	F0		BS=1:1/4 bias BS=0:1/5 bias F2~0: adjust internal OSC frequency for FR frequency.	26.3 us	18.5 us	14.3 us
Set ICON address	0	0	0	1	0	0	AC3	AC2	AC1	AC0		Set ICON address in address counter.	26.3 us	18.5 us	14.3 us
Power/ICON control/Contrast set	0	0	0	1	0	1	Ion	Bon	C5	C4		Ion: ICON display on/off Bon: set booster circuit on/off C5,C4: Contrast set for internal follower mode.	26.3 us	18.5 us	14.3 us
Follower control	0	0	0	1	1	0	Fon	Rab2	Rab1	Rab0		Fon: set follower circuit on/off Rab2~0: select follower amplified ratio.	26.3 us	18.5 us	14.3 us
Contrast set	0	0	0	1	1	1	C3	C2	C1	C0		Contrast set for internal follower mode.	26.3 us	18.5 us	14.3 us

Timing Characteristics

(Ta = -30°C to 85°C)

Item	Signal	Symbol	Condition	VDD=2.7 to 4.5V Rating		VDD=4.5 to 5.5V Rating		Units
				Min.	Max.	Min.	Max.	
				SCL clock frequency	SCL	f_{SCLK}	—	
SCL clock low period	t_{LOW}	1.3	—	1.3		—	us	
SCL clock high period	t_{HIGH}	0.6	—	0.6		—		
Data set-up time	SI	$t_{SU;DAT}$	—	180	—	100	—	ns
Data hold time		$t_{HD;DAT}$	—	0	0.9	0	0.9	us
SCL,SDA rise time	SCL, SDA	t_r	—	20+0.1Cb	300	20+0.1Cb	300	ns
SCL,SDA fall time		t_f	—	20+0.1Cb	300	20+0.1Cb	300	
Capacitive load represent by each bus line		C_b	—	—	400	—	400	pf
Setup time for a repeated START condition	SI	$t_{SU;STA}$	—	0.6	—	0.6	—	us
Start condition hold time		$t_{HD;STA}$	—	0.6	—	0.6	—	us
Setup time for STOP condition		$t_{SU;STO}$	—	0.6	—	0.6	—	us
Bus free time between a Stop and START condition	SCL	t_{BUF}	—	1.3	—	1.3	—	us

● I2C interface

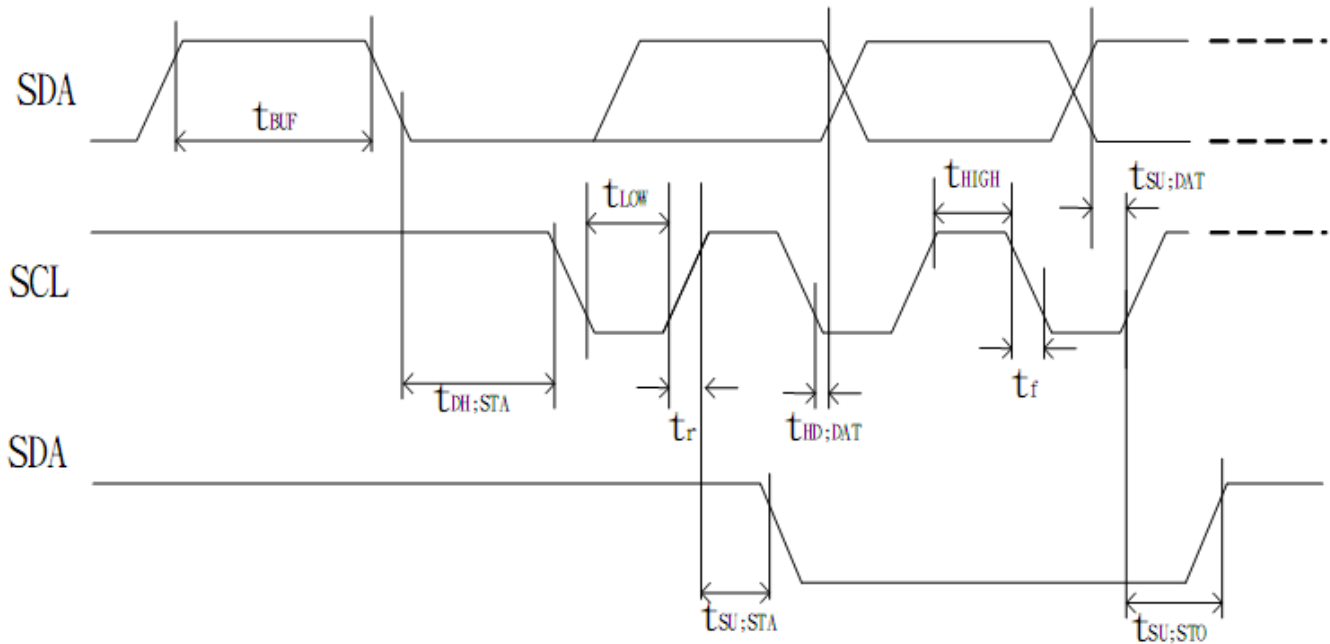

Built-in Font Table

ST7032-0D (ITO option OPR1=0, OPR2=0)

b7-b4 b3-b0	0000	0001	0010	0011	0100	0101	0110	0111	1000	1001	1010	1011	1100	1101	1110	1111
0000	☐	☐	☐	☐	☐	☐	☐	☐	☐	☐	☐	☐	☐	☐	☐	☐
0001	☐	☐	☐	☐	☐	☐	☐	☐	☐	☐	☐	☐	☐	☐	☐	☐
0010	☐	☐	☐	☐	☐	☐	☐	☐	☐	☐	☐	☐	☐	☐	☐	☐
0011	☐	☐	☐	☐	☐	☐	☐	☐	☐	☐	☐	☐	☐	☐	☐	☐
0100	☐	☐	☐	☐	☐	☐	☐	☐	☐	☐	☐	☐	☐	☐	☐	☐
0101	☐	☐	☐	☐	☐	☐	☐	☐	☐	☐	☐	☐	☐	☐	☐	☐
0110	☐	☐	☐	☐	☐	☐	☐	☐	☐	☐	☐	☐	☐	☐	☐	☐
0111	☐	☐	☐	☐	☐	☐	☐	☐	☐	☐	☐	☐	☐	☐	☐	☐
1000	☐	☐	☐	☐	☐	☐	☐	☐	☐	☐	☐	☐	☐	☐	☐	☐
1001	☐	☐	☐	☐	☐	☐	☐	☐	☐	☐	☐	☐	☐	☐	☐	☐
1010	☐	☐	☐	☐	☐	☐	☐	☐	☐	☐	☐	☐	☐	☐	☐	☐
1011	☐	☐	☐	☐	☐	☐	☐	☐	☐	☐	☐	☐	☐	☐	☐	☐
1100	☐	☐	☐	☐	☐	☐	☐	☐	☐	☐	☐	☐	☐	☐	☐	☐
1101	☐	☐	☐	☐	☐	☐	☐	☐	☐	☐	☐	☐	☐	☐	☐	☐
1110	☐	☐	☐	☐	☐	☐	☐	☐	☐	☐	☐	☐	☐	☐	☐	☐
1111	☐	☐	☐	☐	☐	☐	☐	☐	☐	☐	☐	☐	☐	☐	☐	☐

Example Initialization Program

```
/******  
void I2C_out(unsigned char j)          //I2C Output  
{  
    int n;  
    unsigned char d;  
    d=j;  
    for(n=0;n<8;n++){  
        if((d&0x80)==0x80)  
            SDA=1;  
        else  
            SDA=0;  
        d=(d<<1);  
        SCL = 0;  
        SCL = 1;  
        SCL = 0;  
    }  
    SCL = 1;  
    while(SDA==1){  
        SCL=0;  
        SCL=1;  
    }  
    SCL=0;  
}  
/******  
void I2C_Start(void)  
{  
    SCL=1;  
    SDA=1;  
    SDA=0;  
    SCL=0;  
}  
/******  
void I2C_Stop(void)  
{  
    SDA=0;  
    SCL=0;  
    SCL=1;  
    SDA=1;  
}  
/******  
void Show(unsigned char *text)  
{  
    int n;  
    I2C_Start();  
    I2C_out(Slave);  
    I2C_out(Datasend);  
    for(n=0;n<16;n++){  
        I2C_out(*text);  
        ++text;  
    }  
    I2C_Stop();  
}  
/******
```

```
*      Initialization For ST7032i      *
*****/
void init_LCD()
{
I2C_Start();
I2C_out(0x7C);
I2C_out(0x00);
I2C_out(0x38);
delay(10);
I2C_out(0x39);
delay(10);
I2C_out(0x14);
I2C_out(0x78);
I2C_out(0x5E);
I2C_out(0x6D);
I2C_out(0x0C);
I2C_out(0x01);
I2C_out(0x06);
delay(10);
I2C_stop();
}
/*****/
```

Quality Information

Test Item	Content of Test	Test Condition	Note
High Temperature storage	Endurance test applying the high storage temperature for a long time.	+80°C , 48hrs	2
Low Temperature storage	Endurance test applying the low storage temperature for a long time.	-30°C , 48hrs	1,2
High Temperature Operation	Endurance test applying the electric stress (voltage & current) and the high thermal stress for a long time.	+70°C , 48hrs	2
Low Temperature Operation	Endurance test applying the electric stress (voltage & current) and the low thermal stress for a long time.	-20°C , 48hrs	1,2
High Temperature / Humidity Operation	Endurance test applying the electric stress (voltage & current) and the high thermal with high humidity stress for a long time.	+40°C , 90% RH , 48hrs	1,2
Thermal Shock resistance	Endurance test applying the electric stress (voltage & current) during a cycle of low and high thermal stress.	0°C,30min -> 25°C,5min -> 50°C,30min = 1 cycle 10 cycles	
Vibration test	Endurance test applying vibration to simulate transportation and use.	10-55Hz , 15mm amplitude. 60 sec in each of 3 directions X,Y,Z For 15 minutes	3
Static electricity test	Endurance test applying electric static discharge.	VS=800V, RS=1.5kΩ, CS=100pF One time	

Note 1: No condensation to be observed.

Note 2: Conducted after 4 hours of storage at 25°C, 0%RH.

Note 3: Test performed on product itself, not inside a container.

Precautions for using LCDs/LCMs

See Precautions at www.newhavendisplay.com/specs/precautions.pdf

Warranty Information

See Terms & Conditions at http://www.newhavendisplay.com/index.php?main_page=terms