

REVISION RECORD				
REV	ECN	DESCRIPTION	DRFT	DATE

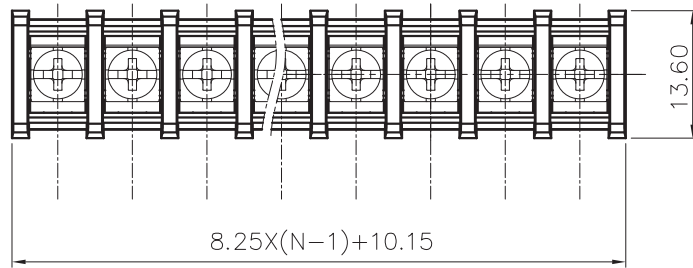

NOTES1:

- UL Standard
- 1.Rated voltage/current : 300V / 20A
- 2.Torque value : M3 , 4.43Lb.in
- 3.Wire range : 22~12AWG

NOTES2:

- 1.Dimension shall be interpreted per ASME Y14.5-2009
- 2.Pitch : 8.25mm
- 3.Withstanding voltage : AC1600V/1Min
- 4.Operating temperature: -40°C~+105°C
- 5.Undimensioned tolerances:

Pitch range in mm		Nominal dimension range in mm				0.1/10
TO	Over	TO	Over	TO	Over	±2'
6	10	10	24	30	60	
±0.15	±0.20	±0.30	±0.30	±0.50	±0.70	±1.00
						±1.30

6.RoHS Compliance



0.80±0.05

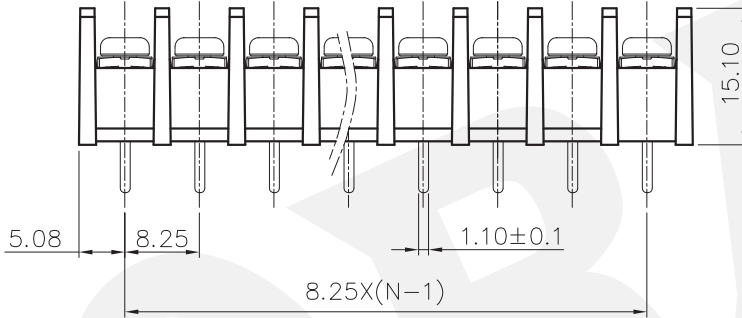

DBT30C-8.25 - XXP - 1Y - 00A (H)

- (Series No.)
- (Poles)
- (Single Pitch)
- (Color): 1.(Grey)
- 2.(Blue)
- 3.(Black)
- 4.(Green)
- 5.(Orange)
- 6.(Red)
- 7.(Transparent)
- 8.(Yellow)
- 9.(White)

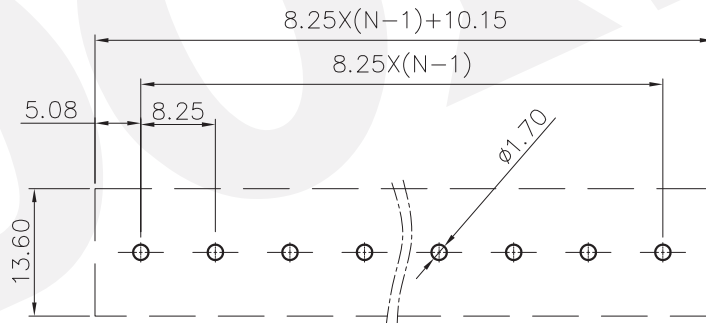

PCB LAYOUT

DETACHED LISTS	PART NO.:	/		
	APPD:	/		
	CHKD:	/		
	DRFT:	/		
		DORABO 慈溪市地博电子有限公司 CIXI DORABO ELECTRONICS CO.,LTD		
		NAME: DBT30C-8.25-XXP-1Y-00A(H)		
		TITLE: CUSTOMER DRAWING	REV	DO
		DRAWING NO.:	SHEET	1/1
		THIRD ANGLE PROJECTION	SCALE	1:1
		MM (INCH)	DO NOT SCALE DRAWING	