

### Description

The API9221 has two supply inputs for highly integrated portable applications, enabling charging from a USB host, wall adapter, or car adapter.

The  $\overline{PPR}$  pin indicates to a host controller that a safe and valid supply is connected to either VUSB or VDC. The higher charge current option from VDC will take priority if both supplies are connected. The host controller can control the state of charging via the enable pin  $\overline{EN}$ . The API9221 implements the constant current/constant voltage (CC/CV) charge algorithm for Lithium based battery cells. The connected cell will be charged to 4.2V with an accuracy of 1% over the entire temperature range. The termination current is programmable via an external resistor,  $R_{IMIN}$ .

The  $\overline{CHG}$  pin indicates when the termination current is reached, and is reset by  $\overline{EN}$ , power off, or battery below 3.9V. The maximum charge current can be programmed independently via the resistors  $R_{IUSB}$  and  $R_{IVDC}$ .

The API9221 comes with several protection features. To prevent system damage, the VUSB pin uses over voltage protection (OVP) at 5.4V, and the VDC OVP is at 6.9V. Above these levels, the non-operating device is protected against damage up to 28V. For control and system start-up the API9221 has a current limited linear regulator.

To protect the chip against excessive power dissipation, temperature monitoring is integrated, which folds back the current to a safe level. As the temperature rises, this fold-back begins at 125°C without completely interrupting charging.

### Applications

- Handheld Consumer Devices
- Cell Phones, PDAs, MP3 Players
- Handheld Test Equipment
- Digital Still Cameras
- Multimedia players

### Pin Assignments

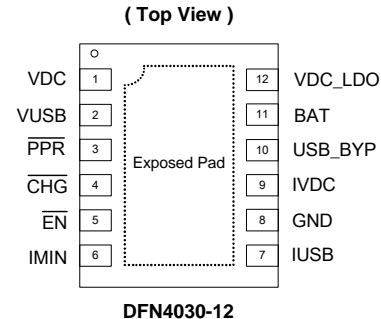

### Features

- Linear Lithium Ion / Lithium Polymer charging IC
- Supplied from USB host or car/wall adapter
- Overvoltage protection USB: 5.4V, wall:6.9V
- Supply inputs safe up to 28V
- Fast charging with maximum current of 1.2A
- Integrated linear regulator of 4.9V at 10mA with current limit
- Separate resistor-programmable charging current for wall and USB
- Resistor programmable end-of-charge
- Current limit on USB bypass path
- Indicator pins for charging and power present
- Enable pin to enable host control charging
- Reverse current protection
- Thermal protection
- DFN4030-12: Available in "Green" Molding Compound (No Br, Sb)
- Lead Free Finish/ RoHS Compliant (Note 1)

Note 1. EU Directive 2002/95/EC (RoHS). All applicable RoHS exemptions applied. Please visit our website at [http://www.diodes.com/products/lead\\_free.html](http://www.diodes.com/products/lead_free.html).

### Typical Application Circuit

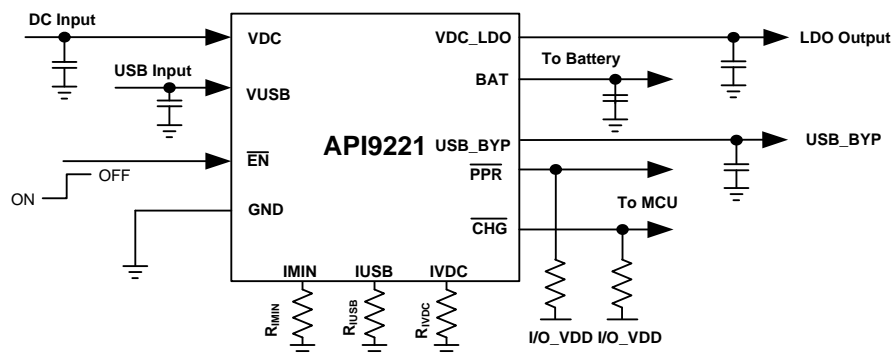

### Pin Descriptions

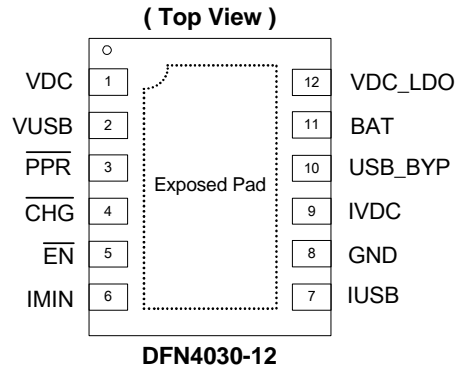

Name	Pin #	Descriptions	
VDC	1	Input pin from a wall AC/DC or car adapter	The recommended input to this pin is 4.5V to 6.7V with a maximum safe value of 28V. If a sufficient voltage is detected on VDC, no charge current is taken from the VUSB pin. Internal OVP trips at 6.9V. The input current can be programmed with a resistor at IVDC (pin 9). Decoupling with a 1 $\mu$ F ceramic capacitor is recommended.
VUSB	2	USB Host device input	The recommended input to this pin is 4.5V to 5.3V with a maximum safe value of 28V. Internal OVP trips at 5.4V. The supply current drawn at this pin is the sum of the charge current and the USB_BYP current. Decoupling with a 1 $\mu$ F ceramic capacitor is recommended. Special attention has to be given to the maximum capacitance on the USB connection. Refer to the USB standard.
$\overline{\text{PPR}}$	3	Power present signal output, active-low	The power present pin can indicate to a host processor that an external source is present and that current can be derived from the input. This is an open drain output pin, which goes LOW when a valid source voltage is connected to either VUSB or VDC. If connected to a processor I/O a pull up resistor should be utilized. Alternatively this pin can be used to drive an indicator LED up to 10mA.
$\overline{\text{CHG}}$	4	Charge indicator output, active-low	Open drain pin is pulled LOW when charging is performed. Goes high when charge current reaches IMIN. Remains high (including top-up), until the battery voltage falls below 3.9V or the device is power cycled or $\overline{\text{EN}}$ is cycled. If connected to a processor I/O a pull up resistor should be utilized. Alternatively this pin can be used to drive an indicator LED up to 10mA.
$\overline{\text{EN}}$	5	Charge enable input, active-low	Logic level input pin to control charging from an external processor. An internal 600k $\Omega$ (nominally) pull-down resistor is provided, This pin normally requires a pull up resistor when connected to a processor I/O.
IMIN	6	Current setting for end-of-charge state	The end-of-charge current is set by a resistor connected from this pin to GND. This applies to charging from either VDC or VUSB.
IUSB	7	Current setting, USB Power	The USB input maximum charging current is set by a resistor connected from this pin to GND. This current is also limited by a thermally controlled current fold-back circuit.
GND	8	Ground	Ground return path.
IVDC	9	Current setting, wall or car adapter	VDC input maximum charging current is set by a resistor connected from this pin to GND. This current is also limited by a thermally controlled current fold-back circuit.
USB_BYP	10	USB Bypass output	Provides an external load path from the USB input, with current limiting. Protected against reverse current.
BAT	11	Battery connector	Connect this pin to the positive terminal of the battery. This pin is also used to monitor the charge state of the battery. It is not recommended to operate the part without a battery connected to this pin. Protected against reverse current.
VDC_LDO	12	LDO output	Low current linear regulator for system supply, available when a valid VDC input supply is used. Stabilize with a 0.1 $\mu$ F to 1 $\mu$ F ceramic capacitor to ground. Protected against reverse current.

**Functional Block Diagram**

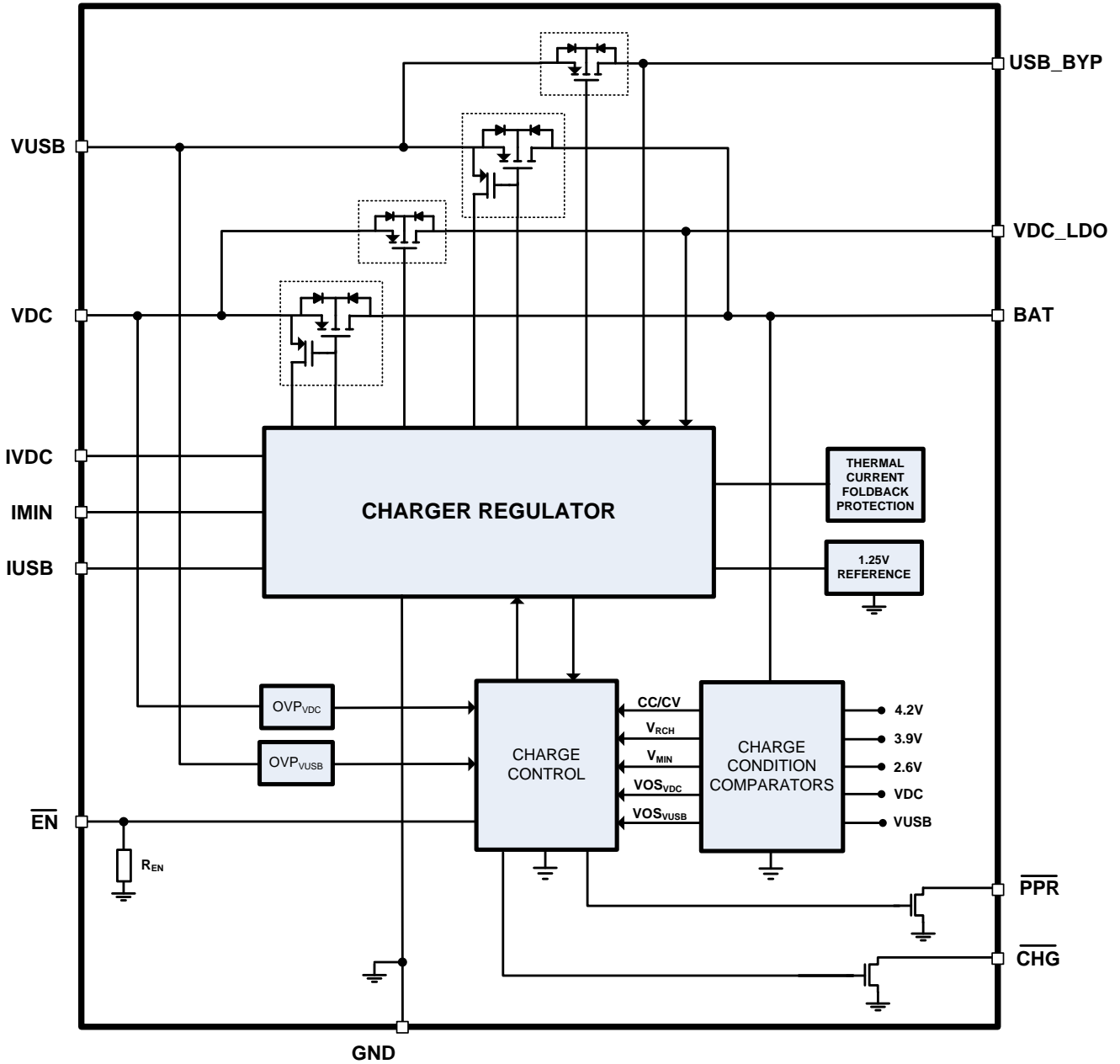

NEW PRODUCT

### Absolute Maximum Ratings

Symbol	Parameter	Rating	Unit
	VDC, VUSB to GND	-0.3 to 28V	V
	$\overline{\text{EN}}$ , I <sub>MIN</sub> , I <sub>VDC</sub> , I <sub>USB</sub> , BAT	-0.3 to 7V	V
	USB_BYP, VDC_LDO	-0.3 to 7V	V
	$\overline{\text{CHG}}$ , PPR	-0.3 to 7V	V
<b>ESD Susceptibility (Note 2)</b>			
HBM	Human Body Model	2	kV
MM	Machine Model	200	V

### Thermal Resistance (Note 3)

Symbol	Parameter	Rating	Unit
$\theta_{JA}$	Junction to Ambient	41	°C/W
$\theta_{JC}$	Junction to Case	3.5	

### Recommended Operating Conditions (Note 4)

Symbol	Parameter	Rating	Unit
	Ambient Temperature Range	-40 to +85	°C
VUSB	Supply Voltage (VUSB)	4.5 to 5.3	V
VDC	Supply Voltage (VDC)	4.5 to 6.7	V
I <sub>VDC_CHRG</sub>	Typical Adapter Charge Current	0.1 to 1.2	A
I <sub>USB_CHRG</sub>	Typical USB Charge Current	46.5 to 465	mA
I <sub>USB-BYP</sub>	Typical USB Bypass Current	0 to 200	mA
I <sub>LDO</sub>	Typical LDO Current	0 to 10	mA

- Notes:
- Semiconductor devices are ESD sensitive and may be damaged by exposure to ESD events. Suitable ESD precautions should be taken when handling and transporting this device.
  - Test condition for DFN4030-12: Measured on approximately 1" square of 1 oz copper.
  - The device function is not guaranteed outside of the recommended operating conditions.

### Electrical Characteristics

API9221 is tested at VDC = VUSB = 5V at an ambient temperature of +25°C unless otherwise noted.

Symbol	Parameter	Test Conditions	Min	Typ.	Max	Unit
<b>CHARGER POWER-ON THRESHOLDS</b>						
VPO <sub>R</sub>	Rising VUSB/VDC Threshold		3.4	3.9	4.2	V
VPO <sub>F</sub>	Falling VUSB/VDC Threshold		3.2	3.7	4.0	V
<b>INPUT VOLTAGE OFFSET</b>						
VOS <sub>HC</sub>	Rising VDC or VUSB, relative to V <sub>BAT</sub>	V <sub>BAT</sub> = 4.0V, use CHG pin to indicate the comparator output	-	150	250	mV
VOS <sub>LC</sub>	Falling VDC or VUSB, relative to V <sub>BAT</sub>	V <sub>BAT</sub> = 4.0V, use CHG pin to indicate the comparator output	20	80	-	mV
<b>STANDBY CURRENT</b>						
I <sub>STANDBY</sub>	BAT Pin Sink Current	$\overline{EN}$ = HIGH or both inputs are floating	-	0.05	0.5	μA
I <sub>VDC</sub>	VDC Pin Supply Current	$\overline{EN}$ = HIGH, I <sub>LDO</sub> = 0	-	380	460	μA
I <sub>VUSB</sub>	VUSB Pin Supply Current	$\overline{EN}$ = HIGH, USB_BYP disconnected	-	330	400	μA
I <sub>VDC_VUSB</sub>	VDC/VUSB Pin Supply Current	$\overline{EN}$ = LOW, I <sub>LDO</sub> = 0, USB_BYP disconnected	-	0.63	1.1	mA
<b>VOLTAGE REGULATION</b>						
V <sub>BATMAX</sub>	Final Output Voltage, BAT Pin	Load = 10mA	4.158	4.2	4.242	V
		Load = 10mA (T <sub>J</sub> = +25°C)	4.174	4.2	4.226	V
r <sub>DS(ON)_VDC</sub>	VDC Linear ON-resistance	V <sub>BAT</sub> = 3.8V, I <sub>VDC</sub> = 0.3A, (T <sub>J</sub> = +25°C)	-	550	-	mΩ
r <sub>DS(ON)_VUSB</sub>	VUSB Linear ON-resistance	V <sub>BAT</sub> = 3.8V, I <sub>VUSB</sub> = 0.3A, (T <sub>J</sub> = +25°C)	-	550	-	mΩ
<b>CHARGE CURRENT</b>						
V <sub>IVDC</sub>	VDC Pin Output Voltage	V <sub>BAT</sub> = 3.8V	1.22	1.25	1.28	V
I <sub>VDC_CHRG</sub>	VDC Constant Current	R <sub>IVDC</sub> = 12.4kΩ, V <sub>BAT</sub> = 2.7V to 3.8V	450	550	600	mA
I <sub>VDC_TRKL</sub>	VDC Trickle Charge Current	R <sub>IVDC</sub> = 12.4kΩ, V <sub>BAT</sub> = 2.2V, given as a % of the I <sub>VDC_CHARGE</sub>	15	17	19	%

### Electrical Characteristics (Continued)

API9221 is tested at  $V_{DC} = V_{USB} = 5V$  at an ambient temperature of  $+25^{\circ}C$  unless otherwise noted.

Symbol	Parameter	Test Conditions	Min	Typ.	Max	Unit
$V_{IUSB}$	IUSB Pin Output Voltage	$V_{BAT} = 3.8V$	1.22	1.25	1.28	V
$I_{USB\_CHRG}$	VUSB Constant Current	$R_{IUSB} = 29.4k\Omega$ , $V_{BAT} = 2.7V$ to $3.8V$	180	232	260	mA
$I_{USB\_TRKL}$	VUSB Trickle Charge Current	$R_{IUSB} = 29.4k\Omega$ , $V_{BAT} = 2.2V$ and if $I_{USB\_CHRG} \leq I_{VDC\_TRKL}$ , then given as a % of the $I_{USB\_CHRG}$	15	17	19	%
		If $I_{USB\_CHRG} \leq I_{VDC\_TRKL}$	-	$I_{USB\_CHRG}$	-	%
$I_{MIN}$	DC and USB End-of-Charge Threshold	$R_{MIN} = 10k\Omega$	40	55	70	mA
<b>PRECONDITIONING CHARGE THRESHOLD</b>						
$V_{MIN}$	Preconditioning Charge Threshold Voltage		2.5	2.6	2.7	V
<b>RECHARGE THRESHOLD</b>						
$V_{RCH}$	Recharge Threshold Voltage		3.8	3.9	4.0	V
<b>PROTECTIONS</b>						
$OVP_{VDC}$	VDC Overvoltage Level		6.7	6.9	7.1	V
$HOVP_{VDC}$	VDC Overvoltage Hysteresis		-	240	340	mV
$OVP_{VUSB}$	VUSB Overvoltage Level		5.3	5.4	5.55	V
$HOVP_{VUSB}$	VUSB Overvoltage Hysteresis		-	150	200	mV
$I_{OCP}$	Short Circuit (USB_BYP)		-	400	600	mA
<b>BYPASS FETS</b>						
$USB\_r_{DS(ON)}$	Resistance VUSB to USB_BYP	Measured at 200mA, $4.3V < V_{DC} < 5.3V$	-	1.16	2.0	$\Omega$
$V_{USB\_DO}$	Dropout VUSB to USB_BYP	$I_{OUT} = 150mA$ $V_{VUSB} > 4.3V$	-	200	-	mV

### Electrical Characteristics (Continued)

API9221 is tested at  $V_{DC} = V_{USB} = 5V$  at an ambient temperature of  $+25^{\circ}C$  unless otherwise noted.

Symbol	Parameter	Test Conditions	Min	Typ.	Max	Unit
<b>INTERNAL TEMPERATURE MONITORING</b>						
$T_{FOLD}$	Current Fold Back Threshold		-	125	-	$^{\circ}C$
<b>LOGIC INPUT AND OUTPUT</b>						
$V_{IH}$	$\overline{EN}$ Pin Logic Input HIGH		1.4	-		V
$V_{IL}$	$\overline{EN}$ Pin Logic Input LOW			-	0.4	V
$R_{EN}$	$\overline{EN}$ Pin Internal Pull-down Resistance		350	600	850	k $\Omega$
$V_{OL}$	$\overline{CHG}$ and $\overline{PPR}$ output voltage LOW	Pin Current = 10mA		-	0.8	V
<b>LINEAR REGULATOR</b>						
$V_{LDO}$	Output Voltage		-	4.94	-	V
$V_{REG}$	Voltage Regulation Accuracy	Initial Accuracy, $I_{LDO} = 10mA$ ; $T_J = +25^{\circ}C$	-1	-	+1	%
		Line regulation $V_{DC} = V_{LDO} + 0.5V$ to 6.5V $T_J = -40^{\circ}C$ to $+125^{\circ}C$	-2.8	-	+2.8	%
		Load regulation $I_{LDO} = 10\mu A$ to 10mA, $V_{DC} = V_{LDO} + 0.5V$ to 6.5V $T_J = -40^{\circ}C$ to $+125^{\circ}C$	-2.8	-	+2.8	%
$V_{DO}$	Dropout ( $V_{DC}$ to $V_{LDO}$ )	$I_{LDO} = 10mA$ , $V_{LDO} = 4.9V$ , $V_{DC} > V_{LDO} + 0.5V$	-	20	50	mV
$I_{LIMIT}$	Current Limit	For $I_{LDO} = 10mA$ , $V_{DC} = 5.5V$	12	-	-	mA

### Functional Description

#### Logic Description

A Logic State Table and diagrams of timing and charge profile are given at the end of this description.

The battery charge function is disabled when the  $\overline{EN}$  input is pulled to logic HIGH. This normally requires an external pull-up resistor connected to the system microcontroller I/O power supply. The API9221 has an internal resistor connected from this pin to GND, typically 600k $\Omega$ . In many applications a suitable pull-up resistor value is 100k $\Omega$ . When  $\overline{EN}$  is pulled LOW or left open circuit, charging is enabled as described below.

There are two open-drain logic outputs,  $\overline{PPR}$  and  $\overline{CHG}$ . Each of these can use an external pull-up resistor to an appropriate supply such as the microcontroller I/O supply, or can be left open circuit. A suitable value is 100k $\Omega$ . Alternatively these can each be used to drive an indicator LED up to a maximum of 10mA.

The output  $\overline{PPR}$  is LOW when a valid power supply voltage is present at the VDC input or at the VUSB input, independent of  $\overline{EN}$ . One of the two input voltages must be greater than the power-on threshold and less than the overvoltage protection threshold.

The output  $\overline{CHG}$  is LOW when the battery is charging, but only until the End-of-Charge (EOC) condition is reached. Together with other conditions as described below, the voltage at the battery connection BAT is used to control the charging current. In the EOC state,  $\overline{CHG}$  is HIGH to indicate that the charging phase has completed and the battery voltage has reached 4.2V ( $\pm 1\%$ ). In this state, the charger remains active and is able to supply load current and top up the battery as necessary.  $\overline{CHG}$  may be re-set as described below under Charge Conditions.

#### Auxiliary Outputs

The USB\_BYB and VDC\_LDO outputs are available independently of the  $\overline{EN}$  input state. This allows a host controller to power up initially.

#### USB Bypass, USB\_BYB

The output USB\_BYB provides power from the USB input when a valid power supply voltage is present at the VUSB input. It is current limited to 400mA (nominally). It is therefore safely limited in current and voltage within the USB standard.

#### VDC Low dropout regulator VDC\_LDO

This output provides a regulated 4.94V supply, up to 10mA, when a valid power supply voltage is present at the VDC input.

#### Charge Conditions

Before charging can begin, one of the two input voltages must also exceed the battery voltage enough to overcome the input-output comparator offset. When one of the supplies satisfies these conditions, and  $\overline{EN}$  is LOW, charging begins regardless of the state of the other supply. The valid input conditions are:

$$\begin{array}{llll} \text{for VDC:} & VPO_R < VDC < OVP_{VDC} & \text{and} & VDC > V_{BAT} + VOS_{HC} \\ \text{for VUSB:} & VPO_R < VUSB < OVP_{VUSB} & \text{and} & VUSB > V_{BAT} + VOS_{HC} \end{array}$$

where  $VPO_R$  is the rising power-on threshold voltage, and  $VOS_{HC}$  is the rising input offset voltage relative to  $V_{BAT}$ . All these threshold voltages have defined hysteresis.

### Functional Description (Continued)

When the charge current falls below  $I_{MIN}$ ,  $\overline{CHG}$  goes HIGH (provided it has an external pull-up). This state is latched and is not re-set until one of the following events occurs:

1.  $\overline{EN}$  is driven HIGH and LOW again
2. The active supply is removed and re-applied
3.  $V_{BAT}$  falls below the re-charge threshold of 3.9V (nominally)

Note that the outputs, BAT, USB\_BYB and VDC\_LDO are reverse current protected. If an external voltage higher than the supply voltage is connected to one of these outputs, that output will be disabled.

#### Charging from Adapter Power (VDC pin)

The battery can be charged from an AC powered wall adapter or in-car adapter at a current of up to 1.2A using this input pin. The maximum charge current is set by an external resistor,  $R_{IVDC}$  connected between the IVDC and GND pins. If VDC is greater than the power-on threshold voltage ( $VPO_R$ ) and less than the over-voltage protection threshold ( $OVP_{VDC}$ ), the battery will begin to charge at a rate dependent on the battery voltage.

When VDC input is as recommended, (4.5V to 6.7V), no charge current is drawn from the VUSB input as VDC takes precedence. Input operation below 4.5V is also possible, but the charging rate may be affected.

The resistor  $R_{IVDC}$  determines the charge current according to

$$I_{VDC} = \frac{6820}{R_{IVDC}} \text{ Amp}$$

For example, a resistor value of 13k $\Omega$  sets a charge current of 0.525A. The recommended IVDC setting is 100mA to 1200mA.

The maximum charge current available may be otherwise limited by the car/wall adapter current limit, by thermal protection within the API9221, or by the  $r_{DS(ON)}$  of the FET in the VDC charging path. For example, if IVDC is set to 1A, there is a voltage drop of 0.6V due the typical  $r_{DS(ON)}$  of 600m $\Omega$  at room temperature. Therefore, the voltage at the VDC input must be at least 4.8V to charge the battery to 4.2V in the minimum time.

The VDC input is safe from damage up to 28V.

#### Charging from USB Power (VUSB pin)

The battery can be charged at a current of up to 0.5A from this pin. In this case the maximum available charge current is set by an external resistor  $R_{IUSB}$  connected between the IUSB and GND pins. If VUSB is greater than the power-on threshold voltage ( $VPO_R$ ) and less than the over-voltage protection threshold ( $OVP_{VUSB}$ ), the battery will begin to charge at a rate dependent on the battery voltage.

The resistor  $R_{IUSB}$  resistor determines the charge current according to

$$I_{USB} = \frac{6820}{R_{IUSB}} \text{ Amp}$$

---

**Functional Description (Continued)**

---

For example, a resistor value of 22kΩ sets a charge current of 0.31A.

The recommended IUSB setting is 46.5mA to 465mA.

The maximum charge current available may be otherwise limited by the external USB current limit, or by thermal protection within the API9221.

The  $r_{DS(ON)}$  of the FET in the USB charging path is typically 600mΩ at room temperature. At the IUSB limit of 465mA, there is a voltage drop of nearly 0.3V. Therefore, the voltage at the VUSB input must be at least 4.5V to charge the battery to 4.2V in the minimum time.

The VUSB input is safe from damage up to 28V.

**Trickle Charge**

When the battery voltage is below the Preconditioning Threshold,  $V_{MIN}$ , the charger is in the Trickle Charge state and the charge current is limited to 18% of the available charge current set by  $R_{IVDC}$  or  $R_{IUSB}$ . If the USB charge current is programmed to a value less than the VDC trickle charge, then this value of the USB current is used in trickle mode (no derating).

When the battery voltage reaches  $V_{MIN}$ , the charge current increases to 100% of the available charge current.

**End-of-Charge Current**

During charging, as the battery voltage approaches the regulated value of 4.2V, the charging current will begin to decrease. Eventually the charging current settles to a value just low enough to maintain the regulated voltage. When the current becomes less than the End-of-Charge threshold current,  $I_{MIN}$ , the logic output  $\overline{CHG}$  goes HIGH. The threshold current is set by an external resistor connected between the IMIN and GND pins. This is independent of whether the VDC or VUSB input is valid.

The resistor at IMIN determines the EOC threshold current according to

$$I_{MIN} = \frac{550}{R_{IMIN}} \text{ Amp}$$

For example, a resistor value of 10kΩ sets the EOC threshold current to 55mA.

**Accuracy**

When the constant voltage phase has been reached, the battery is charged to 4.2V ±1%. This is the maximum error over the ambient temperature range from -40°C to +85°C.

---

**Functional Description (Continued)**

---

**Fault Summary and Protection**

*Overvoltage protection:* If VDC is greater than  $OVP_{VDC}$  (6.9V), the VDC charging path is turned off until VDC falls below  $OVP_{VDC} - HOVP_{VDC}$ , where  $HOVP_{VDC}$  is the OVP hysteresis. Similarly, if VUSB is greater than  $OVP_{VUSB}$  (5.4V), the USB charging path is turned off until VUSB falls below  $OVP_{VUSB} - HOVP_{VUSB}$ .

*USB\_BYP current limit:* The USB\_BYP load current is limited to 400mA (nominally).

*USB\_BYP reverse blocking:* If the voltage at USB\_BYP is greater than VUSB, the USB bypass path is turned off.

*BAT reverse blocking:* If the battery voltage is greater than either VDC or VUSB, the relevant charge path is turned off.

*VDC\_LDO reverse blocking:* If the voltage at VDC\_LDO is greater than VDC, the linear regulator is turned off.

*Thermal protection:* When the junction temperature reaches 125°C, a current foldback circuit is activated. This effectively limits the power dissipation to a safe level.

**Power Supply Filtering and Stability**

At each of the inputs VDC and VUSB, a local decoupling capacitor is required to be connected to GND. A minimum value of 1 $\mu$ F is recommended, ceramic type X7R. (The USB standard sets an upper bound of capacitance somewhat larger than this.)

At the linear regulator output VDC\_LDO, a local decoupling capacitor is required, connected to GND. A value of 1 $\mu$ F is recommended, ceramic type X7R.

At the battery connection BAT, a local decoupling capacitor is required, connected to GND. A value of 1 $\mu$ F is recommended, ceramic type X7R.

**Timing Diagram**

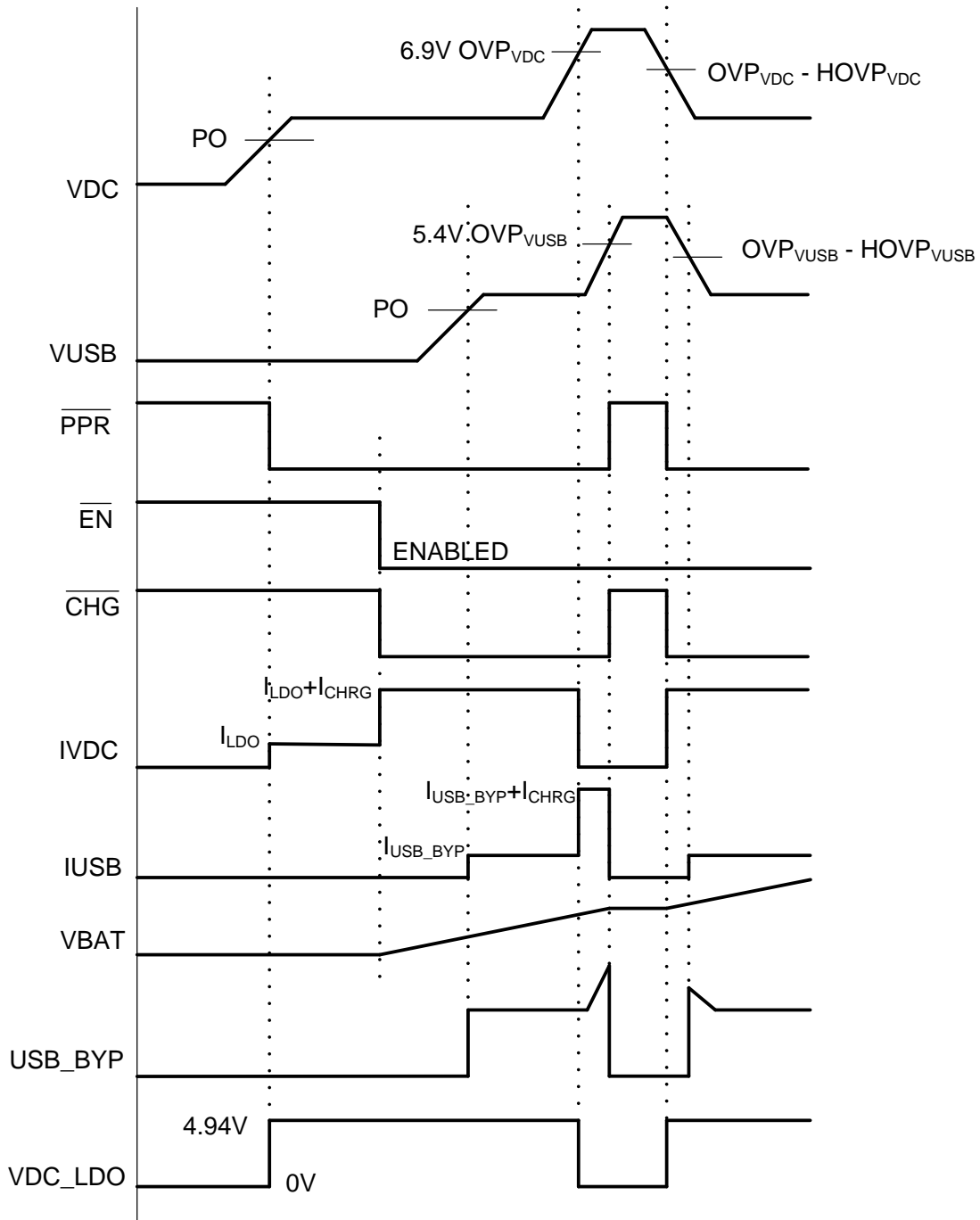

PO = Power-ON  
I<sub>CHRG</sub> = Battery Charging Current

### Logic State Table

INPUTS			OUTPUTS				
$\overline{\text{EN}}$	VDC INPUT VALID*	VUSB INPUT VALID*	$\overline{\text{PPR}}$	$\overline{\text{CHG}}$	Charging State	VDC_LDO	USB_BYP
X	No	No	Hi Z	Hi Z	Off	Off	Off
HIGH	Yes	No	LOW	Hi Z	Off	On	Off
LOW	Yes	No	LOW	LOW	On (VDC)	On	Off
HIGH	No	Yes	LOW	Hi Z	Off	Off	On
LOW	No	Yes	LOW	LOW	On (VUSB)	Off	On
HIGH	Yes	Yes	LOW	Hi Z	Off	On	On
LOW	Yes	Yes	LOW	LOW	On (VDC)	On	On

\* Valid VDC input:  $V_{POR} < VDC < OVP_{VDC}$

\* Valid VUSB input:  $V_{POR} < VUSB < OVP_{VUSB}$

X = don't care

When the charging state is On, the charge current also depends on the battery terminal voltage as described in the text.

### Charging Profile Diagram

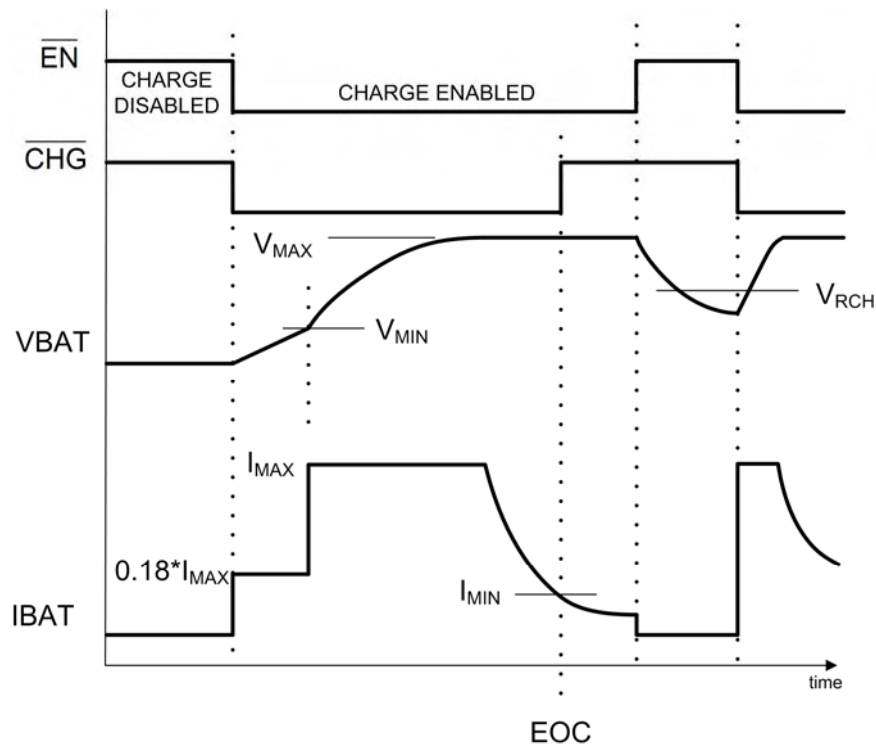

**Ordering Information**

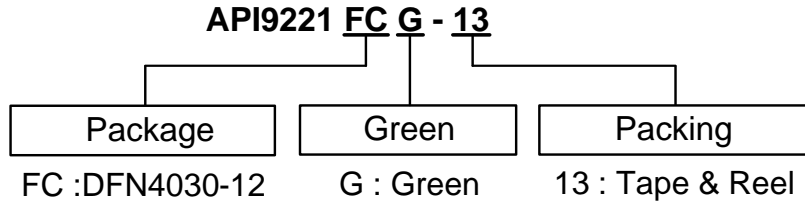

Device	Package Code	Packaging (Note 5)	13" Tape and Reel	
			Quantity	Part Number Suffix
API9221FCG-13	FC	DFN4030-12	3000/Tape & Reel	-13

Notes: 5. Pad layout as shown on Diodes Inc. suggested pad layout document AP02001, which can be found on our website at <http://www.diodes.com/datasheets/ap02001.pdf>.

**Marking Information**

( Top View )

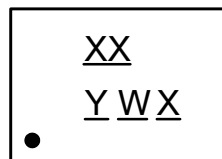

XX : BF : API9221  
Y : Year : 0~9  
W : Week : A~Z : 1~26 week;  
           a~z : 27~52 week;  
           z : represents 52 and 53  
X : A~Z : Green

Part Number	Package	Identification Code
API9221FCG	DFN4030-12	BF



**Package Outline Dimensions (All Dimensions in mm)**

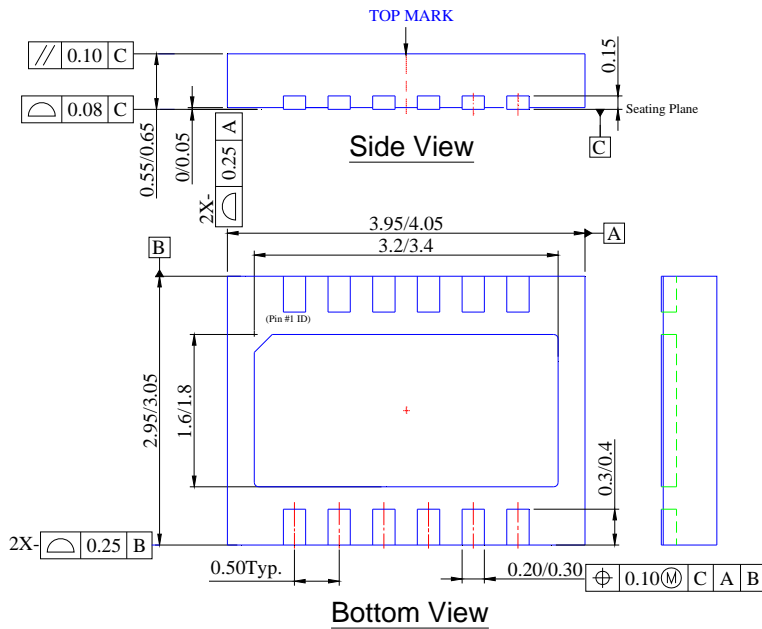

NEW PRODUCT

## Taping Orientation (Note 6)

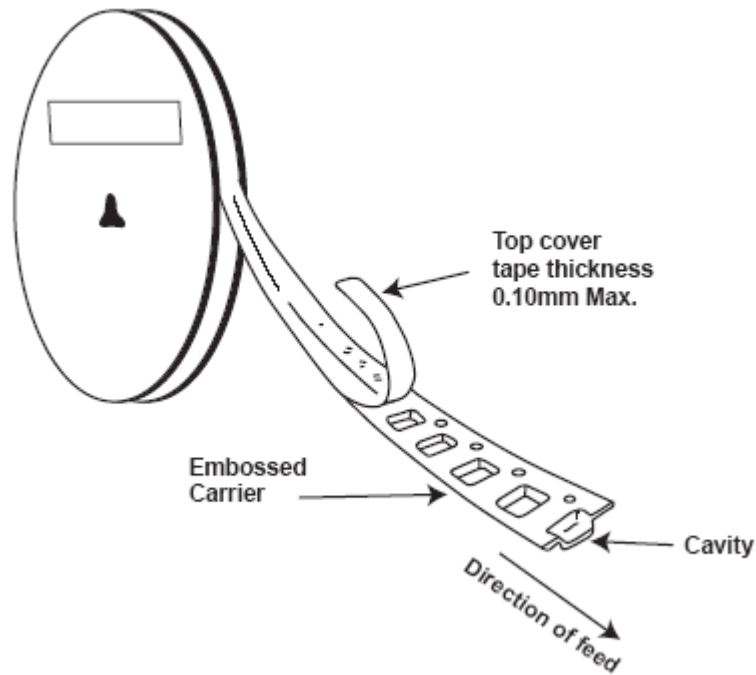
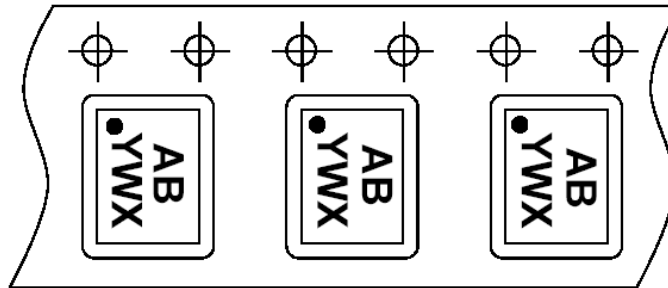

Notes: 6. The taping orientation of the other package type can be found on our website at <http://www.diodes.com/datasheets/ap02007.pdf>

### IMPORTANT NOTICE

DIODES INCORPORATED MAKES NO WARRANTY OF ANY KIND, EXPRESS OR IMPLIED, WITH REGARDS TO THIS DOCUMENT, INCLUDING, BUT NOT LIMITED TO, THE IMPLIED WARRANTIES OF MERCHANTABILITY AND FITNESS FOR A PARTICULAR PURPOSE (AND THEIR EQUIVALENTS UNDER THE LAWS OF ANY JURISDICTION).

Diodes Incorporated and its subsidiaries reserve the right to make modifications, enhancements, improvements, corrections or other changes without further notice to this document and any product described herein. Diodes Incorporated does not assume any liability arising out of the application or use of this document or any product described herein; neither does Diodes Incorporated convey any license under its patent or trademark rights, nor the rights of others. Any Customer or user of this document or products described herein in such applications shall assume all risks of such use and will agree to hold Diodes Incorporated and all the companies whose products are represented on Diodes Incorporated website, harmless against all damages.

Diodes Incorporated does not warrant or accept any liability whatsoever in respect of any products purchased through unauthorized sales channel.

Should Customers purchase or use Diodes Incorporated products for any unintended or unauthorized application, Customers shall indemnify and hold Diodes Incorporated and its representatives harmless against all claims, damages, expenses, and attorney fees arising out of, directly or indirectly, any claim of personal injury or death associated with such unintended or unauthorized application.

Products described herein may be covered by one or more United States, international or foreign patents pending. Product names and markings noted herein may also be covered by one or more United States, international or foreign trademarks.

### LIFE SUPPORT

Diodes Incorporated products are specifically not authorized for use as critical components in life support devices or systems without the express written approval of the Chief Executive Officer of Diodes Incorporated. As used herein:

A. Life support devices or systems are devices or systems which:

1. are intended to implant into the body, or
2. support or sustain life and whose failure to perform when properly used in accordance with instructions for use provided in the labeling can be reasonably expected to result in significant injury to the user.

B. A critical component is any component in a life support device or system whose failure to perform can be reasonably expected to cause the failure of the life support device or to affect its safety or effectiveness.

Customers represent that they have all necessary expertise in the safety and regulatory ramifications of their life support devices or systems, and acknowledge and agree that they are solely responsible for all legal, regulatory and safety-related requirements concerning their products and any use of Diodes Incorporated products in such safety-critical, life support devices or systems, notwithstanding any devices- or systems-related information or support that may be provided by Diodes Incorporated. Further, Customers must fully indemnify Diodes Incorporated and its representatives against any damages arising out of the use of Diodes Incorporated products in such safety-critical, life support devices or systems.

Copyright © 2010, Diodes Incorporated

[www.diodes.com](http://www.diodes.com)