

Buffered Clock Generator for Pentium™ /Triton™ Systems

General Description

The ICS9158-05 is a low cost frequency generator designed specifically to clock Pentium systems using the Triton chip set. Three copies of the CPU clock are available at 50, 60, or 66.7 MHz. Five copies of the synchronous BUS clock run at half the CPU frequency. A 14.318 MHz REFCLK, 12 MHz, KEYBD, and 24 MHz FLOPPY clock are also provided.

Each high drive output is capable of driving a 30pF load with better than 1V/ns typical slew and have a duty cycle of 50±5%. The synchronous outputs are skew controlled to within±250ps and CPU clocks lead BUS clocks by 2-5ns.

Glitch-free start and stop of the CPU and BUS clocks is provided as well as a power-down mode with all clocks forced low and the internal oscillators and PLLs powered-down. Power-up time is less than 10ns. All frequency transitions are gradual and meet the Intel cycle-to-cycle timing specification for 486 and Pentium microprocessors.

Features

- 3 CPU and 5 synchronous BUS clocks
- 50/60/66 MHz and glitch-free stop clock selections
- ±250ps skew between all synchronous outputs
- Outputs drive up to 30pF load with 1V/ns slew
- 2-5ns early CPU clocks support Triton chip set
- Compatible with 486 and Pentium CPUs
- Consumes less than 10µA in power-down mode
- On-chip loop filter components
- 3.0V - 5.5V supply range
- 24-pin SOIC package

Applications

- Ideal for RISC or CISC systems such as 486, Pentium, PowerPC,™ etc. requiring multiple CPU and synchronous BUS clocks.

Block Diagram

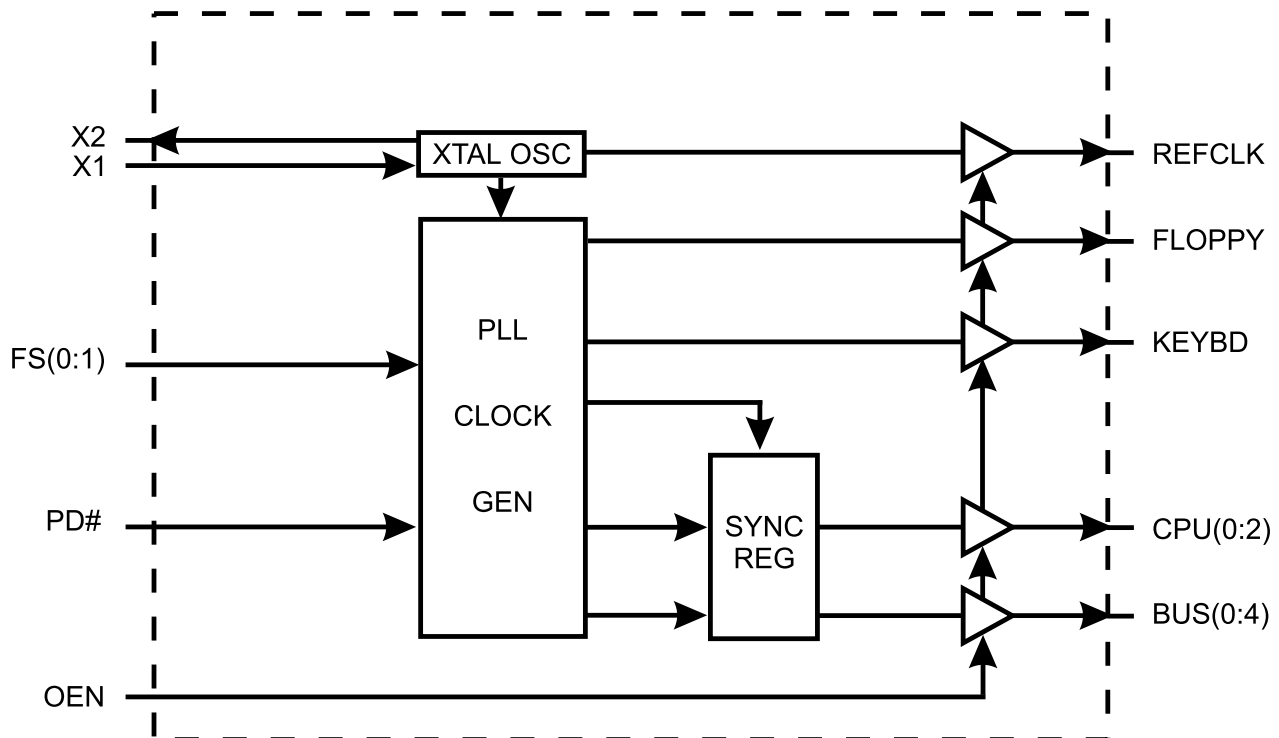

Pentium and Triton are trademarks of Intel Corporation.
PowerPC is a trademark of Motorola Corporation

ICS9158-05

Advanced Information



Pin Configuration

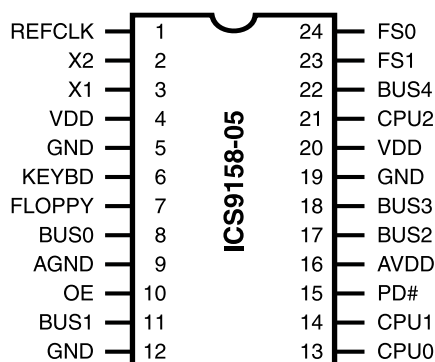

24-Pin SOIC

Functionality

VDD = +5V±10%, TA=0°C to 70°C unless otherwise stated

OE	PD#	FS1	FS0	CPU Ratio	X1,X2, REF (MHz)	CPU (0:2) (MHz)	BUS (0:4) (MHz)
1	1	0	0	14/4xX1	14.318	50	25
1	1	0	1	14/3xX1	14.318	66.7	33.3
1	1	1	0	42/10xX1	14.318	60	30
1	1	1	1	(STOP)	14.318	Low	Low
1	0	X	X	(PWR DOWN)	Low	*Low	*Low
0	X	X	X	-	Tristate	Tristate	Tristate

PD# forces all outputs low and powers-down the oscillator and PLL circuitry, minimizing power consumption. In order to ensure glitch-free start and stop of the CPU and BUS clocks, PD# should be asserted after the CPU and BUS clocks have stopped, and be deasserted 10ms (maximum PLL lock time) prior to starting the clocks.

OE	PD#	FLOPPY (MHz)	KEYBD (MHz)
1	1	24	12
1	0	Low	Low
0	X	Tristate	Tristate

Pin Descriptions for ICS9158-05

PIN NUMBER	PIN NAME	TYPE	DESCRIPTION
1	REFCLK	OUT	14.318 clock output.
2	X2	OUT	Crystal connection, which includes output crystal load capacitance.
3	X1	IN	Crystal connection, which includes crystal load capacitance and feedback bias for a nominal 14.31818 MHz parallel-resonance 12pF crystal.
4	VDD	PWR	Digital POWER SUPPLY.
5	GND	PWR	Digital GROUND.
6	KEYBD	OUT	12 MHz keyboard clock output.
7	FLOPPY	OUT	24 MHz floppy disk clock output.
8	BUS0	OUT	BUS clock output.
9	AGND	PWR	ANALOG GROUND.
10	OE	IN	OUTPUT ENABLE. Tristates all outputs when low.*
11	BUS1	OUT	BUS clock output.
12	GND	PWR	Digital GROUND.
13	CPU0	OUT	CPU clock output.
14	CPU1	OUT	CPU clock output.
15	PD#	IN	Power-down input shuts off both PLL stages when low.*
16	AVDD	PWR	ANALOG power supply.
17	BUS2	OUT	CPU clock output.
18	BUS3	OUT	BUS clock output.
19	GND	PWR	Digital GROUND.
20	VDD	PWR	Digital POWER SUPPLY.
21	CPU2	OUT	CPU clock output.
22	BUS4	OUT	BUS clock output.
23	FS1	IN	Clock frequency select #1.*
24	FS0	IN	Clock frequency select #0.*

* Input pin has internal pull-up to VDD.



Absolute Maximum Ratings

- AVDD, VDD referenced to GND 7V
- Operating temperature under bias. 0°C to +70°C
- Storage temperature -40°C to +150°C
- Voltage on I/O pins referenced to GND. GND -0.5V to VDD +0.5V
- Power dissipation 0.5 Watts

Stresses above those listed under Absolute Maximum Ratings may cause permanent damage to the device. This is a stress rating only and functional operation of the device at these or any other conditions above those indicated in the operational sections of the specifications is not implied. Exposure to absolute maximum rating conditions for extended periods may affect product reliability.

Electrical Characteristics at 5V

V_{DD} = +5V±10%, T_A=0°C to 70°C unless otherwise stated

DC Characteristics						
PARAMETER	SYMBOL	TEST CONDITIONS	MIN	TYP	MAX	UNITS
Input Low Voltage	V _{IL}				0.8	V
Input High Voltage	V _{IH}		2.0			V
Input Low Current	I _{IL}	V _{IN} =0V (Pull-up)	-20			μA
Input High Current	I _{IH}	V _{IN} =V _{DD}	-5		5	μA
Output Low Voltage	V _{OL}	I _{OL} =20.0mA		0.25	0.4	V
Output High Voltage ¹	V _{OH}	I _{OH} =-30mA	2.4	3.5		V
Output Low Current ¹	I _{OL}	V _{OL} =0.8V	45	65		mA
Output High Current ¹	I _{OH}	V _{OH} =2.0V		-55	-35	mA
Supply Current	I _{DD}	No load, 66 MHz		67	100	mA
Output Frequency Change over Supply and Temperature ¹	F _D	With respect to typical frequency		0.002	0.01	%
Short circuit current ¹	I _{SC}	Each output clock	25	56		mA
Pull-up resistor value ¹	R _{PU}	Input pin		680		kΩ
Input Capacitance ¹	C _i	Except X1, X2			8	pf
Load Capacitance ¹	C _L	Pins X1, X2		20		pf

Note 1: Parameter is guaranteed by design and characterization. Not 100% tested in production.



Electrical Characteristics (*continued*)

V_{DD} = +5V±10%, T_A=0°C to 70°C unless otherwise stated

AC Characteristics						
PARAMETER	SYMBOL	TEST CONDITIONS	MIN	TYP	MAX	UNITS
Output Rise time, 0.8 to 2.0V (Note 1)	t _r	30pf load	-	1	1.5	ns
Rise time, 20% to 80% V _{DD} (Note 1)	t _r	30pf load	-	2.5	3	ns
Output Fall time, 2.0 to 0.8V ¹	t _f	30pf load	-	0.5	1.5	ns
Fall time, 80% to 20% V _{DD} ¹	t _f	30pf load	-	1.5	2	ns
Duty cycle ¹	d _t	30pf load	45/55	48/52	55/45	%
Jitter, one sigma ¹	t _{j1s}	As compared with clock period		0.5	2.0	%
Jitter, absolute	t _{jab}		-5	2	5	%
Jitter, absolute	t _{jab}	25-66MHz clocks	-250		250	ps
Input Frequency	f _i			14.318		MHz
Clock skew between CPU and 2XCPU outputs	T _{sk}			100	250	ps
Frequency Transition Time ¹	t _{ft}	From 4 to 50 MHz		13	20	ms

Note 1: Parameter is guaranteed by design and characterization. Not 100% tested in production.



Electrical Characteristics at 3.3V

V_{DD} = +3.3V±10%, T_A=0°C to 70°C unless otherwise stated

DC Characteristics						
PARAMETER	SYMBOL	TEST CONDITIONS	MIN	TYP	MAX	UNITS
Input Low Voltage	V _{IL}				0.8	V
Input High Voltage	V _{IH}		2.0			V
Input Low Current	I _{IL}	V _{IN} =0V(Pull-up)	-10			μA
Input High Current	I _{IH}	V _{IN} =V _{DD}	-5			μA
Output Low Voltage	V _{OL}	I _{OL} =10mA			0.1V _{DD}	V
Output High Voltage ¹	V _{OH}	I _{OH} =-5mA	0.85V _{DD}			V
Output Low Current ¹	I _{OL}	V _{OL} =0.2V _{DD}	20	30		mA
Output High Current ¹	I _{OH}	V _{OH} =0.7V _{DD}		-15	-10	mA
Supply Current	I _{DD}	No load, 66 MHz		43	65	mA
Output Frequency Change over Supply and Temperature ¹	F _D	With respect to typical frequency		0.002	0.01	%
Short Circuit Current ¹	I _{SC}	Each output clock	25	56		mA
Pull-up Resistor Value ¹	R _{PU}	Input pin		900		kΩ
Input Capacitance ¹	C _i	Except X1, X2			8	pF
Load Capacitance ¹	C _L	Pins X1, X2		20		pF

AC Characteristics						
PARAMETER	SYMBOL	TEST CONDITIONS	MIN	TYP	MAX	UNITS
Output Rise time, 0.8 to 2.0V ¹	t _r	30pF load	-	1	3.0	ns
Rise time, 20% to 80% V _{DD} ¹	t _r	30pF load	-	2.5	4.0	ns
Output Fall time, 2.0 to 0.8V ¹	t _f	30pF load	-	0.5	2.5	ns
Fall time, 80% to 20% V _{DD} ¹	t _f	30pF load	-	1.5	4.0	ns
Duty cycle ¹	d _t	30pF load	40/50	44/46	50/40	%
Jitter, one sigma ¹	t _{j1s}	As compared with clock period		0.5	2.0	%
Jitter, absolute ¹	t _{jab}			2	5	%
Jitter, absolute ¹	t _{jab}	25-66 MHz clocks			300	ps
Input Frequency	f _i			14.318		MHz
Clock skew window between CPU and 2XCPU outputs ¹	T _{sk}			100	250	ps
Frequency Transition time ¹	t _{ft}	From 4 to 50 MHz		13	20	ms

Note 1: Parameter is guaranteed by design and characterization. Not 100% tested in production.

ICS9158-05

Advanced Information



ICS9158-05 CPU Clock Decoding Table

(using 14.318 MHz input. All frequencies in MHz)

VDD=5V±10% or 3.3V±10%, TEMP=0-70°C

OE	PD#	FS1	FS0	CPU Ratio	X1,X2, REF (MHz)	CPU (0:2) (MHz)	BUS (0:4) (MHz)
1	1	0	0	14/4xX1	14.318	50	25
1	1	0	1	14/3xX1	14.318	66.7	33.3
1	1	1	0	42/10xX1	14.318	60	30
1	1	1	1	(STOP)	14.318	Low	Low
1	0	X	X	(PWR DOWN)	Low	*Low	*Low
0	X	X	X	-	Tristate	Tristate	Tristate

PD# forces all outputs low and powers-down the oscillator and PLL circuitry, minimizing power consumption. In order to ensure glitch-free start and stop of the CPU and BUS clocks, PD# should be asserted after the CPU and BUS clocks have stopped, and be deasserted 10ms (maximum PLL lock time) prior to starting the clocks.

OE	PD#	FLOPPY (MHz)	KEYBD (MHz)
1	1	24	12
1	0	Low	Low
0	X	Tristate	Tristate

Frequency Transitions

A key feature of the **ICS9158-05** is its ability to provide smooth, glitch-free frequency transitions on the CPU and BUS clocks when the frequency select pins are changed. The frequency transition rate does not violate the Intel 486 or Pentium specification of less than 0.1% frequency change per clock period.

Using an Input Clock as a Reference

The **ICS9158-05** is designed to accept a 14.318 MHz crystal as the input reference. With some external changes, it is possible to use a crystal oscillator or other clock sources. Please see application note AAN04 for details on driving the **ICS9158-05** with a clock.

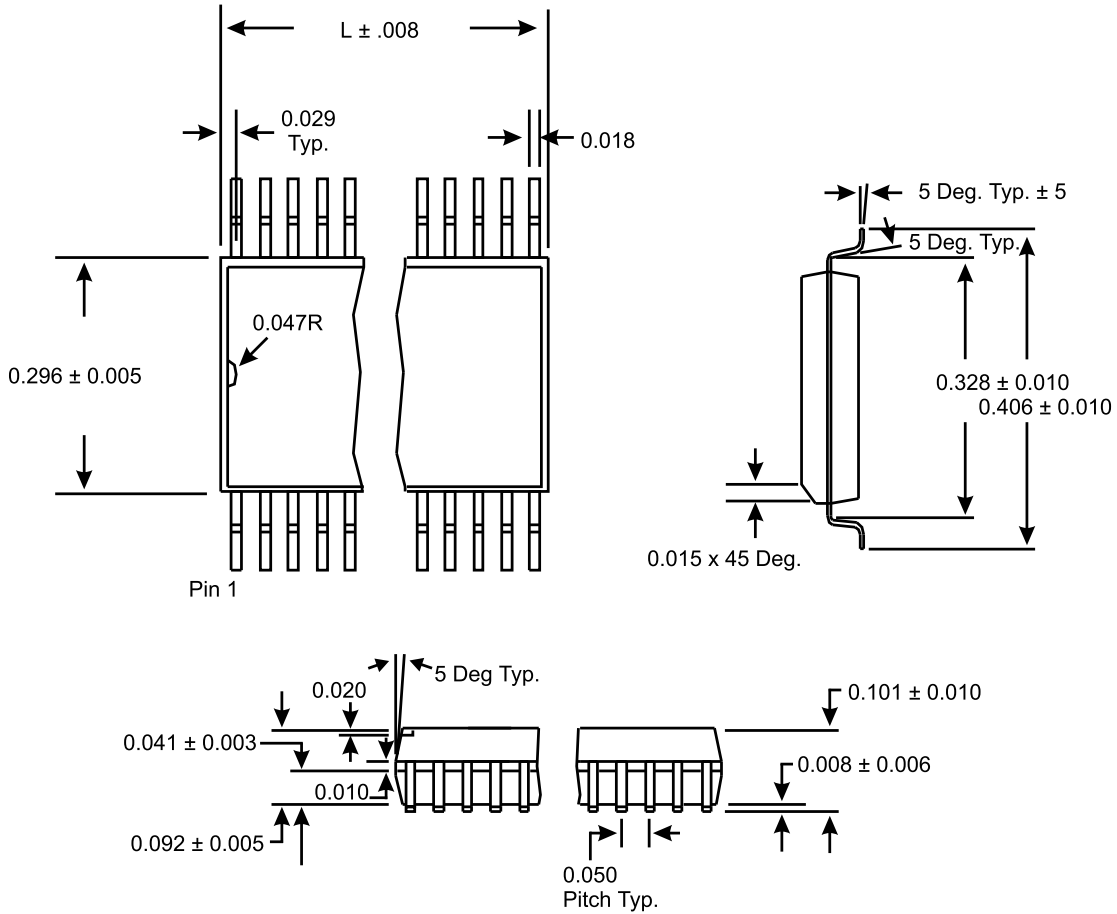

24 Lead SOIC

LEAD COUNT	24L
DIMENSION L	0.604

Ordering Information

ICS9158-05M

Example:

ICS XXXX-PPP M

