

General Purpose Transistors PNP Silicon

1. FEATURES

- Silicon PNP transistor in a SOT-23 Plastic Package
- High DC Current Gain, Low Collector to Emitter Saturation Voltage, Qualified to AEC-Q101 Standards for High Reliability, HF Product.
- General purpose amplifier and switching, Meet the stringent requirements of automotive applications

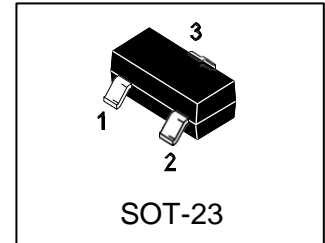

2. DEVICE MARKING AND ORDERING INFORMATION

Device	Marking	Shipping
2N3906S-AB	Q2A	3000/Tape&Reel

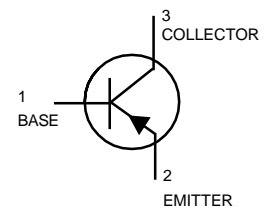

3. MAXIMUM RATINGS(Ta = 25°C)

Parameter	Symbol	Limits	Unit
Collector–Emitter Voltage	VCEO	-40	Vdc
Collector–Base Voltage	VCBO	-40	Vdc
Emitter–Base Voltage	VEBO	-5	Vdc
Collector Current — Continuous	IC	-200	mAdc

4. THERMAL CHARACTERISTICS

Parameter	Symbol	Limits	Unit
Total Device Dissipation, FR-5 Board (Note 1) @ TA = 25°C Derate above 25°C	PD	225 1.8	mW mW/°C
Thermal Resistance, Junction–to–Ambient(Note 1)	RθJA	556	°C/W
Junction and Storage temperature	TJ,Tstg	-55~+150	°C

1. FR-5 = 1.0×0.75×0.062 in.



2N3906S-AB

5. ELECTRICAL CHARACTERISTICS (Ta= 25°C)

OFF CHARACTERISTICS

Characteristic	Symbol	Min.	Typ.	Max.	Unit
Collector–Emitter Breakdown Voltage (IC = -1.0 mAdc, IB = 0)	VBR(CEO)	-40	-	-	V
Collector–Base Breakdown Voltage (IC = -10 µAdc, IE = 0)	VBR(CBO)	-40	-	-	V
Emitter–Base Breakdown Voltage (IE = -10 µAdc, IC = 0)	VBR(EBO)	-5	-	-	V
Collector ~ Base Leakage Current (VCE = -30 Vdc, IE = 0)	ICBO	-	-	-50	nA
Emitter~ Base Leakage Current (VCE = -3V, IC =0V)	IEBO	-	-	-50	nA

ON CHARACTERISTICS (Note 2.)

DC Current Gain (IC = -0.1 mAdc, VCE = -1.0 Vdc)	HFE	60	-	-	
(IC = -1.0 mAdc, VCE = -1.0 Vdc)		80	-	-	
(IC = -10 mAdc, VCE = -1.0 Vdc)		100	-	300	
(IC = -50 mAdc, VCE = -1.0 Vdc)		60	-	-	
(IC = -100 mAdc, VCE = -1.0 Vdc)		30	-	-	
Collector–Emitter Saturation Voltage (IC = -10 mAdc, IB = -1.0 mAdc)	VCE(sat)	-	-	-0.25	V
(IC = -50 mAdc, IB = -5.0 mAdc)		-	-	-0.4	
Base–Emitter Saturation Voltage (IC = -10 mAdc, IB = -1.0 mAdc)	VBE(sat)	-0.65	-	-0.85	V
(IC = -50 mAdc, IB = -5.0 mAdc)		-	-	-0.95	

SMALL–SIGNAL CHARACTERISTICS

Current–Gain — Bandwidth Product (IC = -10mAdc, VCE= -20Vdc, f = 100MHz)	fT	250	-	-	MHz
Output Capacitance (VCB = -5.0 Vdc, IE = 0, f = 1.0 MHz)	Cobo	-	-	4.5	pF

WITCHING CHARACTERISTICS

Delay Time	(VCC = -3.0 Vdc, VBE=0.5Vdc, IC = -10mAdc, IB1 = -1.0 mAdc)	td	-	-	35	ns
Rise Time		tr	-	-	35	
Storage Time	(VCC = -3.0 Vdc, IC = -10 mAdc, IB1 = IB2 = -1.0 mAdc)	ts	-	-	225	
Fall Time		tf	-	-	75	

6. ELECTRICAL CHARACTERISTICS CURVES

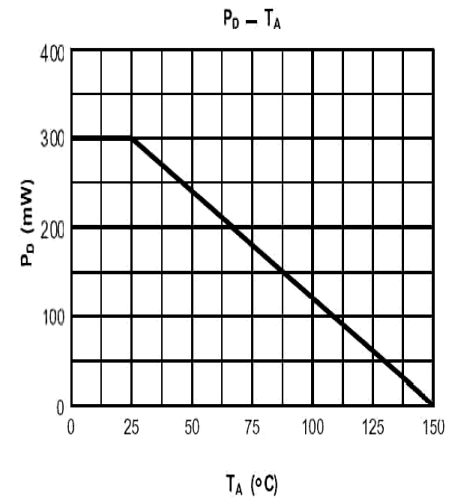
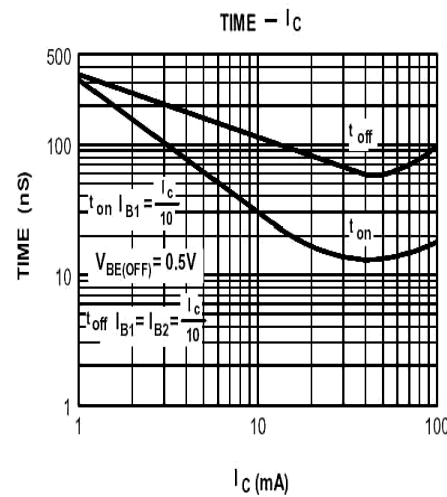
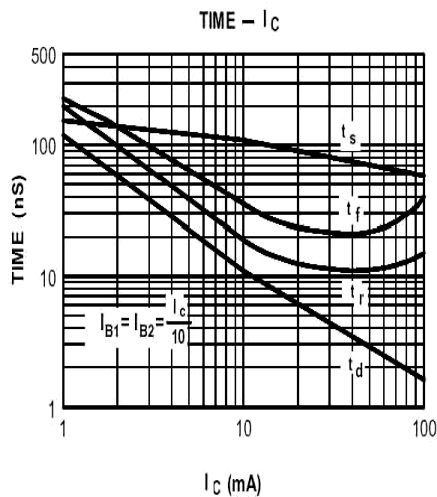
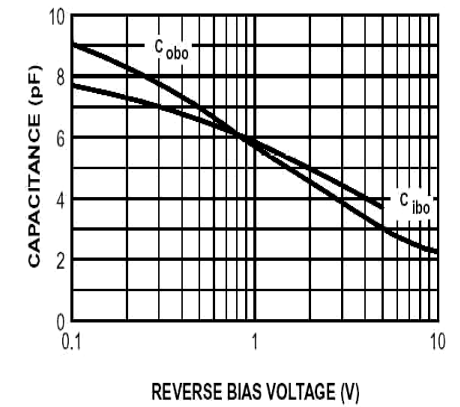
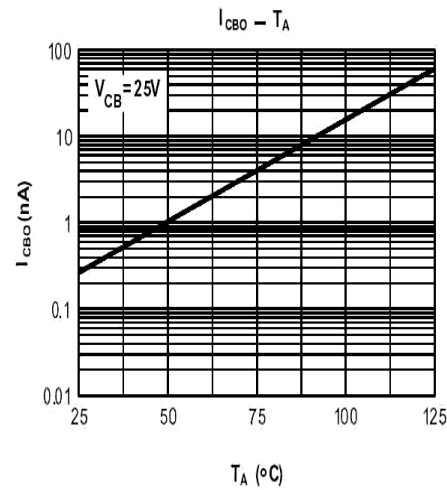
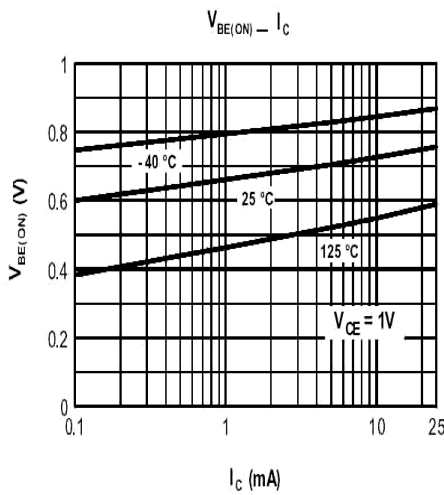
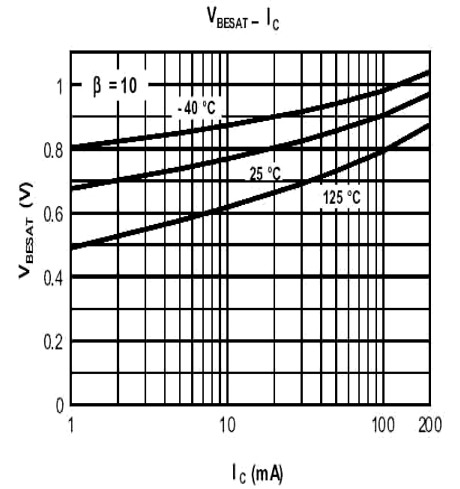
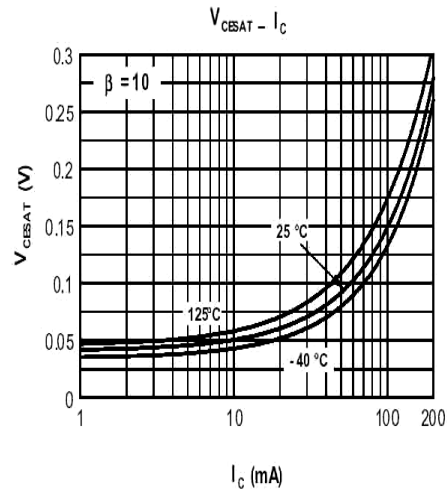
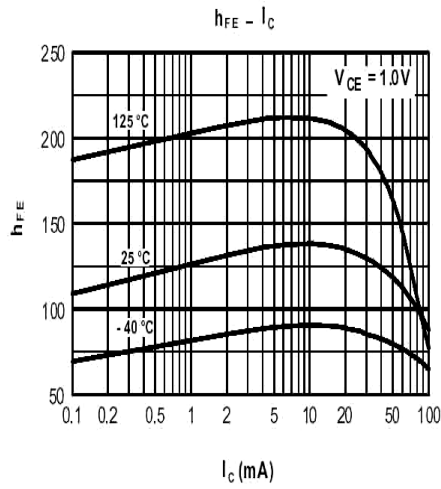

7. Package Dimensions(SOT-23)

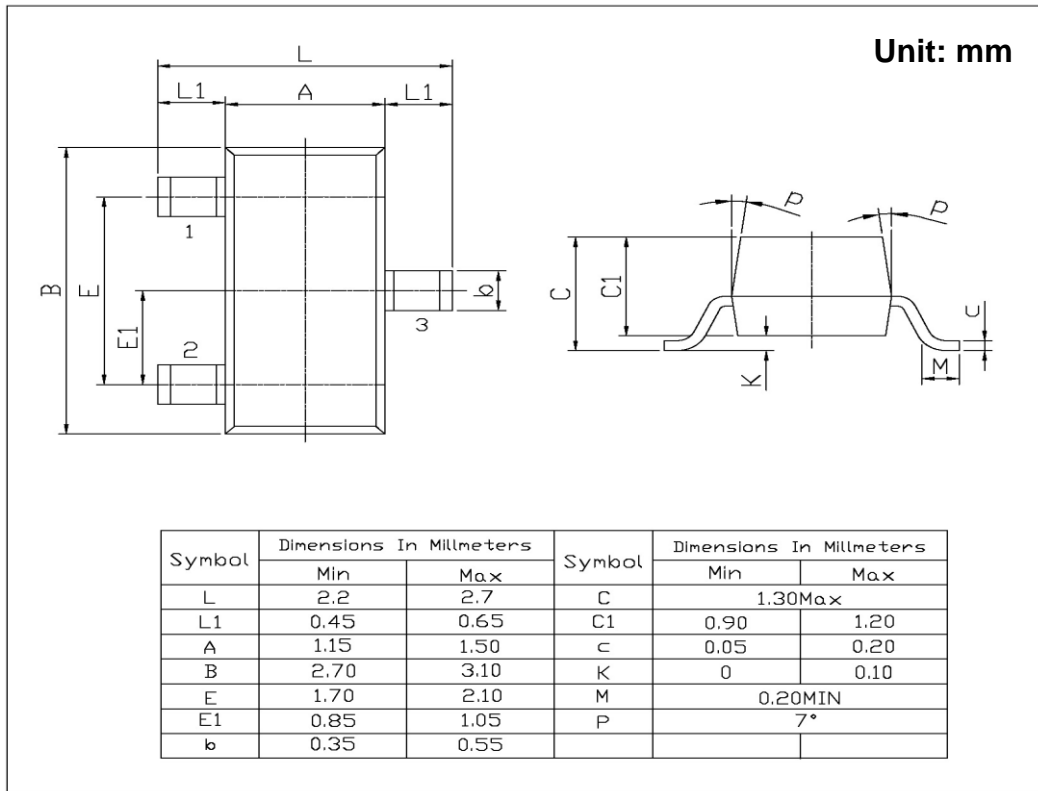

8.SOLDERING FOOTPRINT

