

EC13 Series

- RoHS Compliant (Pb-free)
- HCMOS/TTL output
- 3.3V supply voltage
- 14 pin DIP package
- Stability to ± 20 ppm
- Custom lead length, gull wing options available

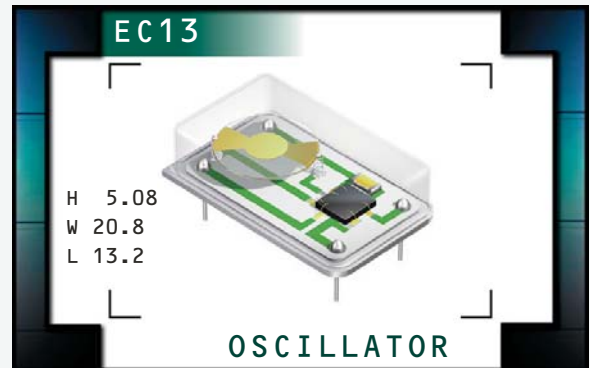

ELECTRICAL SPECIFICATIONS

Frequency Range (MHz)	0.250MHz to 125.000MHz	
Operating Temperature Range	0°C to 70°C -40°C to 85°C	
Storage Temperature Range	-55°C to 125°C	
Supply Voltage (V_{DD})	3.3V _{DC} ± 0.3 V _{DC}	
Input Current	0.250MHz to 24.000MHz	10mA Maximum
	24.001MHz to 70.000MHz	25mA Maximum
	70.001MHz to 125.000MHz	45mA Maximum
Frequency Tolerance / Stability	Inclusive of all conditions: Calibration Tolerance at 25°C, ± 100 ppm, ± 50 ppm, ± 25 ppm, or Frequency Stability over the Operating Temperature Range, ± 20 ppm Maximum (0°C to 70°C Only) Supply Voltage Change, Output Load Change, First Year Aging at 25°C, Shock, and Vibration	
Output Voltage Logic High (V_{OH})	w/ TTL Load	2.4V _{DC} Minimum
	w/ HCMOS Load	2.7V _{DC} Minimum
Output Voltage Logic Low (V_{OL})	w/ TTL Load	0.4V _{DC} Maximum
	w/ HCMOS Load	0.5V _{DC} Maximum
Rise Time / Fall Time	10% to 90% of Waveform w/HCMOS Load or 0.4V _{DC} to 2.4V _{DC} w/TTL Load	10 nSeconds Max. ≤ 24.000 MHz 10 nSeconds Max. ≤ 24.000 MHz
	10% to 90% of Waveform w/HCMOS Load	6 nSeconds Max. 24.000MHz to 70.000MHz
	10% to 90% of Waveform w/HCMOS Load	4 nSeconds Max. 70.001MHz to 125.000MHz
Duty Cycle	at 50% of Waveform	50 ± 10 (%) (Standard) or 50 ± 5 (%) (Optional)
Load Drive Capability	≤ 24.000 MHz	2TTL or 15pF HCMOS Load
	> 24.000 MHz	15pF HCMOS Load
Tri-State Input Voltage	V _{IH} : No Connection	Enables Output
	V _{IH} : ≥ 2.2 V _{DC}	Enables Output
	V _{IL} : ≤ 0.8 V _{DC}	Disables Output: High Impedance
Aging (at 25°C)	± 5 ppm / year Maximum	
Start Up Time	10 mSeconds Maximum	
Period Jitter: Absolute	± 100 pSeconds Maximum	
Period Jitter: One Sigma	± 25 pSeconds Maximum	

MANUFACTURER
ECLIPTEK CORP.

CATEGORY
OSCILLATOR

SERIES
EC13

PACKAGE
14 pin DIP

VOLTAGE
3.3V

CLASS
OS20

REV. DATE
08/06

PART NUMBERING GUIDE

EC13 00 ET T TS - 50.000M - G

FREQUENCY TOLERANCE / STABILITY

00=±100ppm Maximum (Standard)
 45=±50ppm Maximum, 25=±25ppm Maximum
 20=±20ppm Maximum

OPERATING TEMP. RANGE

Blank=0°C to 70°C (Standard), ET=-40°C to 85°C

DUTY CYCLE

Blank=50±10(%) (Standard), T=50±5(%)

AVAILABLE OPTIONS

Blank=None (Standard)
 CLXXX=Custom Lead Length
 G=Full Size Gull Wing

FREQUENCY

OUTPUT CONTROL FUNCTION

Blank = No Connect
 TS=Tri-State Enable High

NOTES

MECHANICAL DIMENSIONS ALL DIMENSIONS IN MILLIMETERS

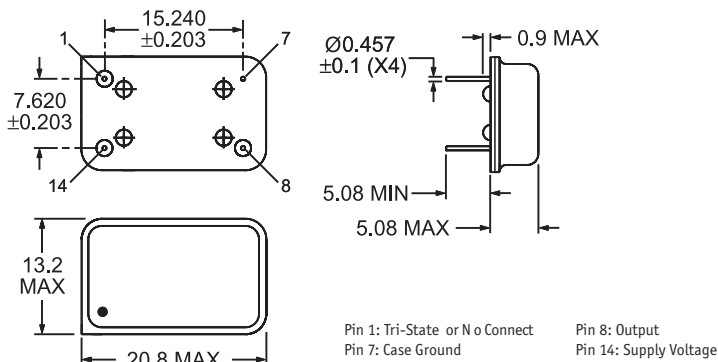

ENVIRONMENTAL/MECHANICAL SPECIFICATIONS

Characteristic	Specification
Fine Leak Test	MIL-STD-883, Method 1014, Condition A
Gross Leak Test	MIL-STD-883, Method 1014, Condition C
Mechanical Shock	MIL-STD-202, Method 213, Condition C
Vibration	MIL-STD-883, Method 2007, Condition A
Lead Integrity	MIL-STD-883, Method 2004
Solderability	MIL-STD-883, Method 2002
Temperature Cycling	MIL-STD-883, Method 1010
Resistance to Soldering Heat	MIL-STD-883, Method 210
Resistance to Solvents	MIL-STD-883, Method 215

MARKING SPECIFICATIONS

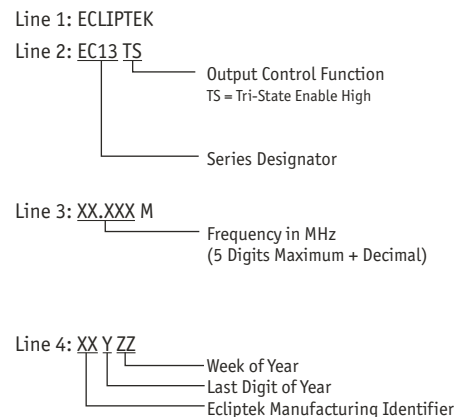

Note: Pin 1 shall be designated with a dot

MANUFACTURER ECLIPTEK CORP.	CATEGORY OSCILLATOR	SERIES EC13	PACKAGE 14 pin DIP	VOLTAGE 3.3V	CLASS OS20	REV. DATE 08/06
--------------------------------	------------------------	----------------	-----------------------	-----------------	---------------	--------------------

EC13 Series



ECLIPTEK[®]
CORPORATION

- RoHS Compliant (Pb-free)
- HCMOS/TTL output
- 3.3V supply voltage
- 8 pin DIP package
- Stability to ± 20 ppm
- Custom lead length, gull wing options available

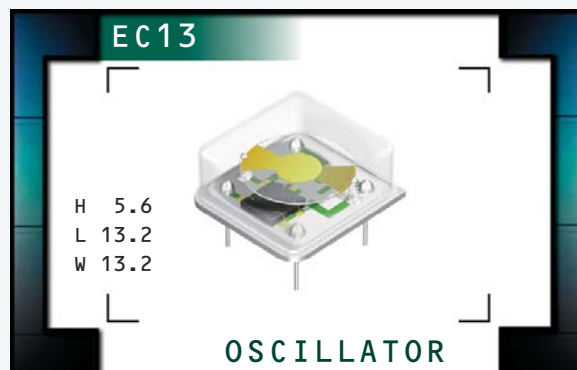

ELECTRICAL SPECIFICATIONS

Frequency Range (MHz)	0.250MHz to 125.000MHz	
Operating Temperature Range	0°C to 70°C -40°C to 85°C	
Storage Temperature Range	-55°C to 125°C	
Supply Voltage (V_{DD})	3.3V _{DC} \pm 0.3V _{DC}	
Input Current	0.250MHz to 24.000MHz	10mA Maximum
	24.001MHz to 70.000MHz	25mA Maximum
	70.001MHz to 125.000MHz	45mA Maximum
Frequency Tolerance / Stability	Inclusive of all conditions: Calibration Tolerance at 25°C, Frequency Stability over the Operating Temperature Range, Supply Voltage Change, Output Load Change, First Year Aging at 25°C, Shock, and Vibration	± 100 ppm, ± 50 ppm, ± 25 ppm, or ± 20 ppm Maximum (0°C to 70°C Only)
Output Voltage Logic High (V_{OH})	w/ TTL Load	2.4V _{DC} Minimum
	w/ HCMOS Load	2.7V _{DC} Minimum
Output Voltage Logic Low (V_{OL})	w/ TTL Load	0.4V _{DC} Maximum
	w/ HCMOS Load	0.5V _{DC} Maximum
Rise Time / Fall Time	10% to 90% of Waveform w/HCMOS Load or 0.4V _{DC} to 2.4V _{DC} w/TTL Load	10 nSeconds Max. \leq 24.000MHz 10 nSeconds Max. \leq 24.000MHz
	10% to 90% of Waveform w/HCMOS Load	6 nSeconds Max. 24.000MHz to 70.000MHz
	10% to 90% of Waveform w/HCMOS Load	4 nSeconds Max. 70.001MHz to 125.000MHz
Duty Cycle	at 50% of Waveform	50 \pm 10(%) (Standard) or 50 \pm 5(%) (Optional)
Load Drive Capability	\leq 24.000MHz	2TTL or 15pF HCMOS Load
	$>$ 24.000MHz	15pF HCMOS Load
Tri-State Input Voltage	V _{IH} : No Connection	Enables Output
	V _{IH} : \geq 2.2V _{DC}	Enables Output
	V _{IL} : \leq 0.8V _{DC}	Disables Output: High Impedance
Aging (at 25°C)	± 5 ppm / year Maximum	
Start Up Time	10 mSeconds Maximum	
Period Jitter: Absolute	± 100 pSeconds Maximum	
Period Jitter: One Sigma	± 25 pSeconds Maximum	

MANUFACTURER
ECLIPTEK CORP.

CATEGORY
OSCILLATOR

SERIES
EC13

PACKAGE
8 pin DIP

VOLTAGE
3.3V

CLASS
OS21

REV. DATE
08/06

PART NUMBERING GUIDE

EC13 00 HS ET TTS - 50.000M - G TR

FREQUENCY TOLERANCE / STABILITY

00=±100ppm Maximum (Standard)
 45=±50ppm Maximum, 25=±25ppm Maximum
 20=±20ppm Maximum

PACKAGE

HS=Half Size 8 Pin DIP

OPERATING TEMP. RANGE

Blank=0°C to 70°C (Standard), ET=-40°C to 85°C

DUTY CYCLE

Blank=50 ±10(%) (Standard), T=50 ±5(%)

PACKAGING OPTIONS

TR= Tape & Reel (only offered with Half Size G and Half Size G2 Options)

AVAILABLE OPTIONS

Blank=None (Standard)
 CLXXX=Custom Lead Length
 G=Half Size Gull Wing
 G2=Half Size Gull Wing

FREQUENCY

OUTPUT CONTROL FUNCTION

Blank=None (No Connection on Pin 1)
 TS=Tri-State Enable High

MECHANICAL DIMENSIONS ALL DIMENSIONS IN MILLIMETERS

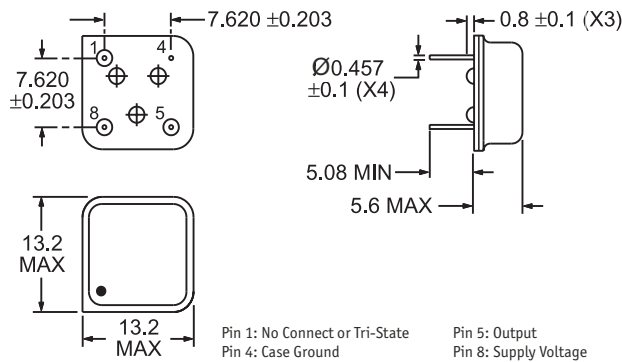

TAPE AND REEL DIMENSIONS ALL DIMENSIONS IN MILLIMETERS

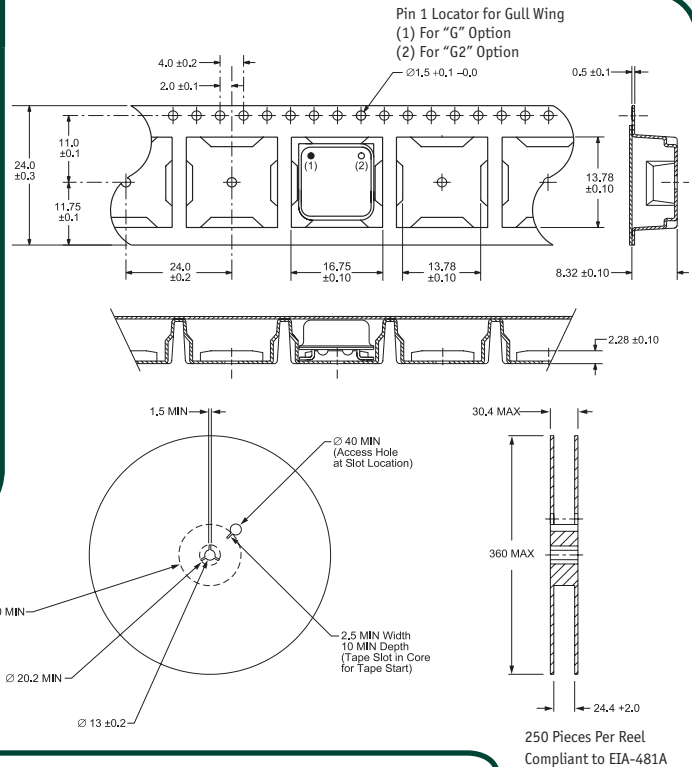

MARKING SPECIFICATIONS

Line 1: ECLIPTEK

Line 2: EC13 TS

Output Control Function
 Blank = None (No Connection on Pin 1)
 TS = Tri-State Enable High
 Series Designator

Line 3: XX.XXX M

Frequency in MHz
 (5 Digits Maximum + Decimal)

Line 4: XX Y ZZ

Week of Year
 Last Digit of Year
 Ecliptek Manufacturing Identifier

Note: Pin 1 shall be designated with a dot

ENVIRONMENTAL/MECHANICAL SPECIFICATIONS

Characteristic	Specification
Fine Leak Test	MIL-STD-883, Method 1014, Condition A
Gross Leak Test	MIL-STD-883, Method 1014, Condition C
Mechanical Shock	MIL-STD-202, Method 213, Condition C
Vibration	MIL-STD-883, Method 2007, Condition A
Lead Integrity	MIL-STD-883, Method 2004
Solderability	MIL-STD-883, Method 2002
Temperature Cycling	MIL-STD-883, Method 1010
Resistance to Soldering Heat	MIL-STD-883, Method 210
Resistance to Solvents	MIL-STD-883, Method 215

MANUFACTURER ECLIPTEK CORP.	CATEGORY OSCILLATOR	SERIES EC13	PACKAGE 8 pin DIP	VOLTAGE 3.3V	CLASS OS21	REV. DATE 08/06
--------------------------------	------------------------	----------------	----------------------	-----------------	---------------	--------------------