

QUAD DARLINGTON SWITCH

- FOUR NON INVERTING INPUTS WITH ENABLE
- OUTPUT VOLTAGE UP TO 60 V
- OUTPUT CURRENT UP TO 1.8 A
- VERY LOW SATURATION VOLTAGE
- TTL COMPATIBLE INPUTS
- INTEGRAL FAST RECIRCULATION DIODES

DESCRIPTION

The L6221 monolithic quad darlington switch is designed for high current, high voltage switching applications. Each of the four switches is controlled by a logic input and all four are controlled by a common enable input. All inputs are TTL-compatible for direct connection to logic circuits.

Each switch consists of an open-collector darlington transistor plus a fast diode for switching applications with inductive device loads. The emitters of the four switches are commoned. Any number of inputs and

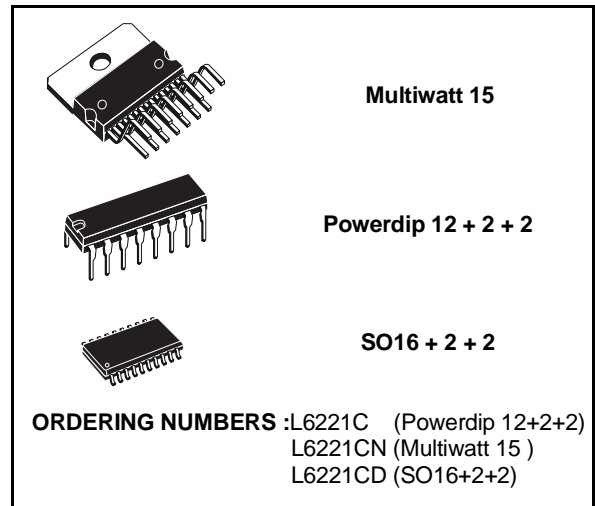

outputs of the same device may be paralleled. Three versions are available : the L6221C mounted in a Powerdip 12 + 2 + 2 package and the L6221CN mounted in a 15--lead Multiwatt package, the L6221CD in SO16+2+2 package.

BLOCK DIAGRAM

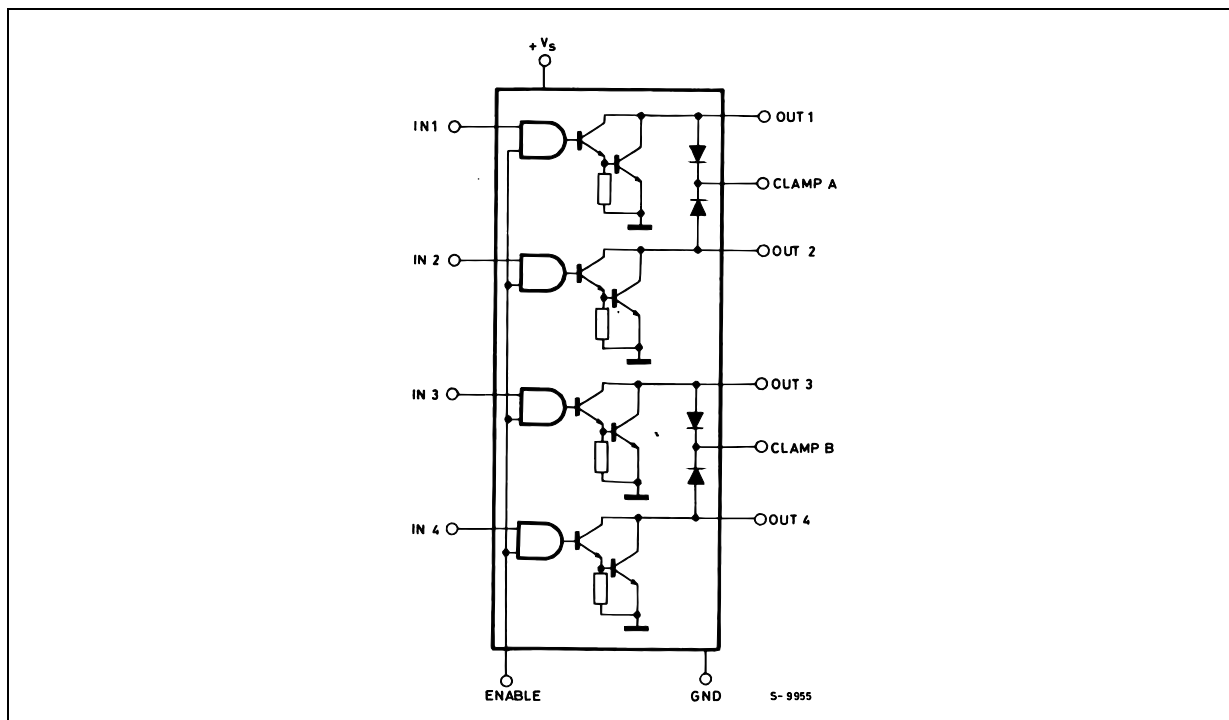

L6221C

THERMAL DATA

Symbol	Parameter		SO20	Powerdip	Multiwatt15	Unit
$R_{th\ j-pins}$	Thermal Resistance Junction-pins	Max.	17	14	–	°C/W
$R_{th\ j-case}$	Thermal Resistance Junction-case	Max.	–	–	3	°C/W
$R_{th\ j-amb}$	Thermal Resistance Junction-ambient	Max.	80	80	35	°C/W

PIN CONNECTIONS (top views)

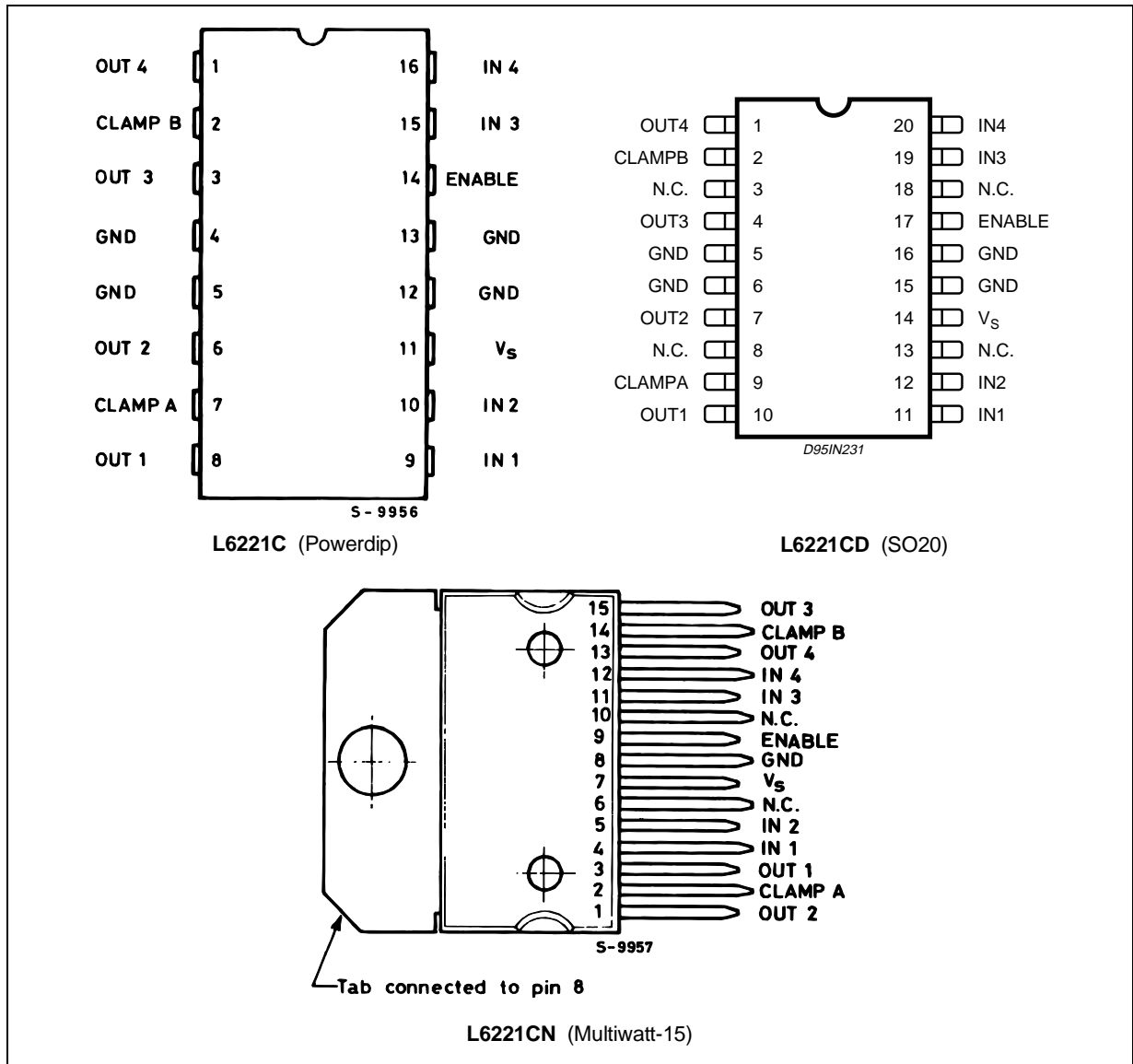

ABSOLUTE MAXIMUM RATINGS

Symbol	Parameter	Value	Unit	
V_O	Output Voltage	60	V	
V_S	Logic Supply Voltage	7	V	
V_{IN}, V_{EN}	Input Voltage, Enable Voltage	V_S		
I_C	Continuous Collector Current (for each channel)	1.8	A	
		for L6221CD 1.2	A	
I_C	Collector Peak Current (repetitive, duty cycle = 10% $t_{on} = 5ms$)	2.5	A	
		for L6221CD 1.7	A	
I_C	Collector Peak Current (non repetitive, $t = 10\mu s$)	3.2	A	
		for L6221CD 2.2	A	
T_{op}	Operating Temperature Range (junction)	-40 to +150	°C	
T_{stg}	Storage Temperature Range	-55 to +150	°C	
I_{sub}	Output Substrate Current	350	mA	
P_{tot}	Total Power Dissipation	at $T_{pins} = 90^\circ C$ (powerdip)	4.3	W
		at $T_{case} = 90^\circ C$ (multiwatt)	20	W
		at $T_{case} = 90^\circ C$ (SO20)	3.5	W
		at $T_{amb} = 70^\circ C$ (powerdip)	1	W
		at $T_{amb} = 70^\circ C$ (multiwatt)	2.3	W
		at $T_{amb} = 70^\circ C$ (SO20)	1	W

TRUTH TABLE

Enable	Input	Power Out
H	H	ON
H	L	OFF
L	X	OFF

For each input : H = High level
L = Low level
X = Don't care

PIN FUNCTIONS (see block diagram)

Name	Function
IN 1	Input to Driver 1
IN 2	Input to Driver 2
OUT 1	Output of Driver 1
OUT 2	Output of Driver 2
CLAMP A	Diode Clamp to Driver 1 and Driver 2
IN 3	Input to Driver 3
IN 4	Input to Driver 4
OUT 3	Output of Driver 3
OUT 4	Output of Driver 4
CLAMP B	Diode Clamp to Driver3 and Driver 4
ENABLE	Enable Input to All Drivers
VS	Logic Supply Voltage
GND	Common Ground

L6221C

ELECTRICAL CHARACTERISTICS Refer to The Test Circuit to Fig.1 to Fig.9 ($V_S = 5V$, $T_{amb} = 25^\circ C$ unless otherwise specified)

Symbol	Parameter	Test Condition	Min.	Typ.	Max.	Unit
V_S	Logic Supply Voltage		4.5		5.5	V
I_S	Logic Supply Current	All outputs ON $I_C = 0.7A$ All outputs OFF			20 20	mA mA
I_{CEX}	Output Leakage Current	$V_{CE} = 60V$ $V_{EN} = V_{ENH}$ $V_{IN} = V_{INL}$			1	mA
$V_{CE(sat)}$	Collector Emitter Saturation Voltage (one input on; all others inputs off).	$V_S = 4.5V$ $V_{IN} = V_{INH}$ $V_{EN} = V_{ENH}$ $I_C = 1A$ (* $I_C = 2A$)			1.4 1.85	V V
V_{INL}, V_{ENL}	Input Low Voltage				0.8	V
I_{INL}, I_{ENL}	Input Low Current	$V_{IN} = V_{INL}$ $V_{EN} = V_{ENL}$			-100	μA
V_{INH}, V_{ENH}	Input High Voltage		2			V
I_{INH}, I_{ENH}	Input High Current	$V_{IN} = V_{INH}$ $V_{EN} = V_{ENH}$			100	μA
I_R	Clamp Diode Leakage Current	$V_R = 60V$ $V_{EN} = V_{ENH}$ $V_{IN} = V_{INL}$			100	μA
V_F	Clamp Diode Forward Voltage	$I_F = 1A$ $I_F = 2A$ (*)			1.8 2.2	V V
$t_{d(on)}$	Turn on Delay Time	$V_P = 5V$ $R_L = 10\Omega$			2	ms
$t_{d(off)}$	Turn off Delay Time	$V_P = 5V$ $R_L = 10\Omega$			5	μs
ΔI_S	Logic Supply Current Variation	$V_{IN} = 5V$ $V_{EN} = 5V$ $I_{out} = -500mA$ for Each Channel			150	mA

(*) Only for L6221C - L6221CN types

TEST CIRCUITS

(X) = Referred to Multiwatt package

X = Referred to Powerdip package

Figure 1 : Logic supply current.

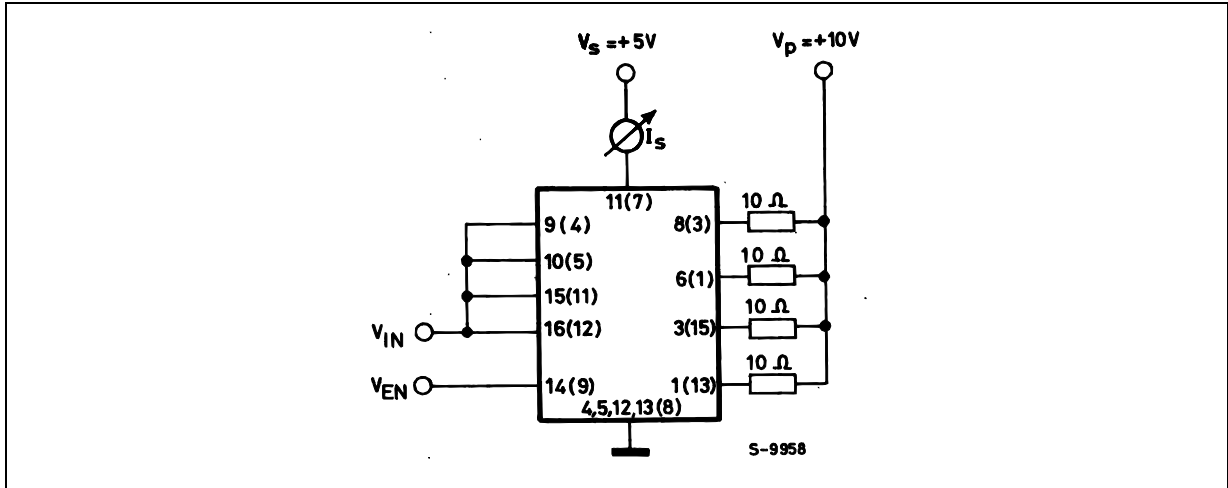

Set $V_{IN} = 4.5V$, $V_{EN} = 0.8V$, or $V_{IN} = 0.8V$, $V_{EN} = 4.5V$, for I_S (all outputs off)
 Set $V_{IN} = 2V$, $V_{EN} = 2V$, for I_S (all outputs on)

Figure 2 : Output Sustaining Voltage.

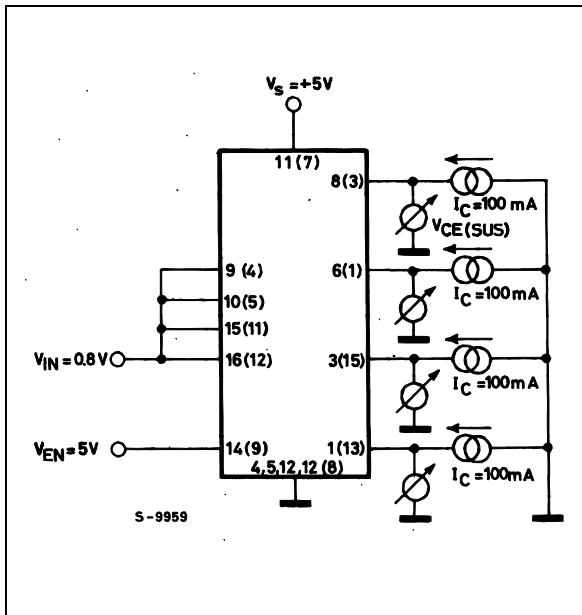
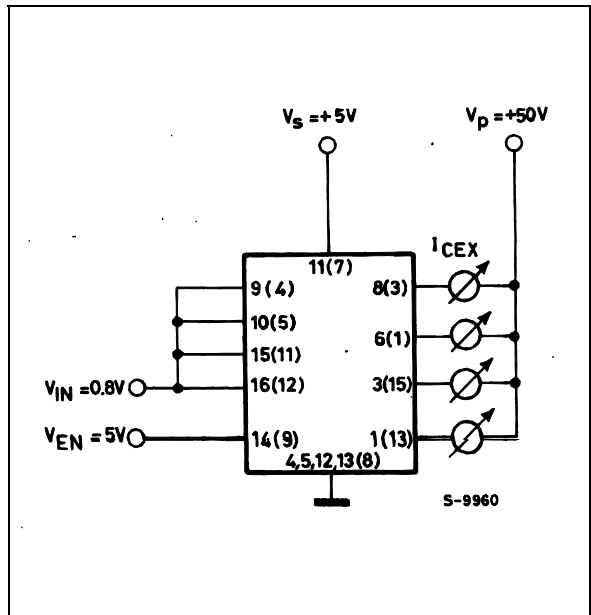

Figure 3 : Output Leakage Current.



$V_P = +60V$

Figure 4 : Collector-emitter Saturation Voltage.

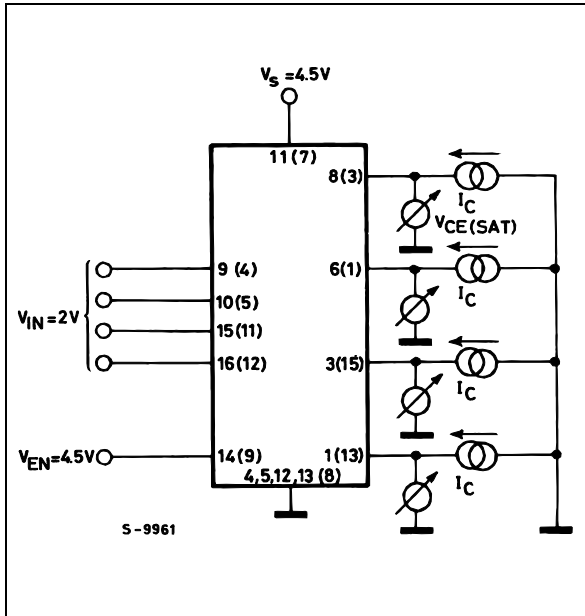
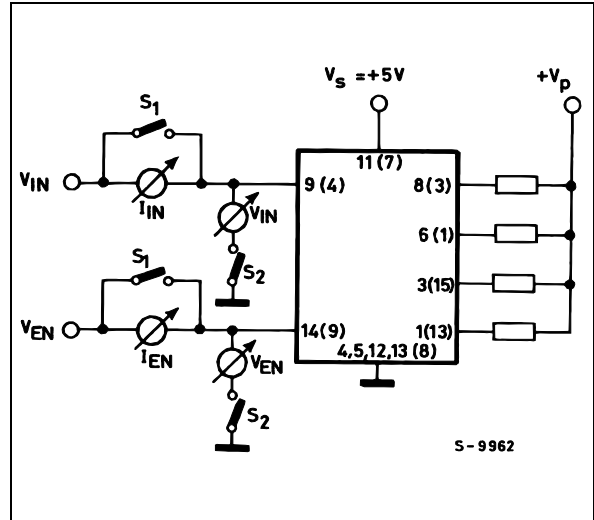
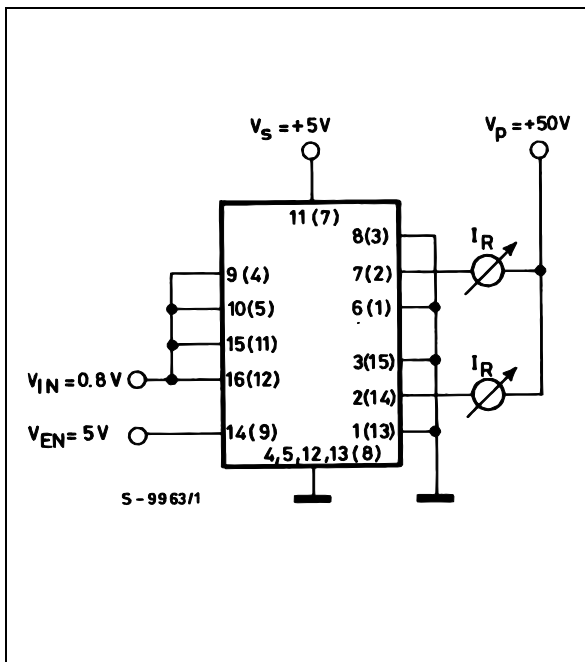

Figure 5 : Logic Input Characteristics.



Set S1, S2 open, $V_{IN}, V_{EN} = 0.8V$ for $I_{IN} L, I_{EN} L$
 Set S1, S2 open, $V_{IN}, V_{EN} = 2V$ for $I_{IN} H, I_{EN} H$
 Set S1, S2 close, $V_{IN}, V_{EN} = 0.8V$ for $V_{IN} L, V_{EN} L$
 Set S1, S2 close, $V_{IN}, V_{EN} = 2V$ for $V_{IN} H, V_{EN} H$

Figure 6 : Clamp Diode Leakage Current.



$V_p = +60V$

Figure 7 : Clamp Diode Forward Voltage.

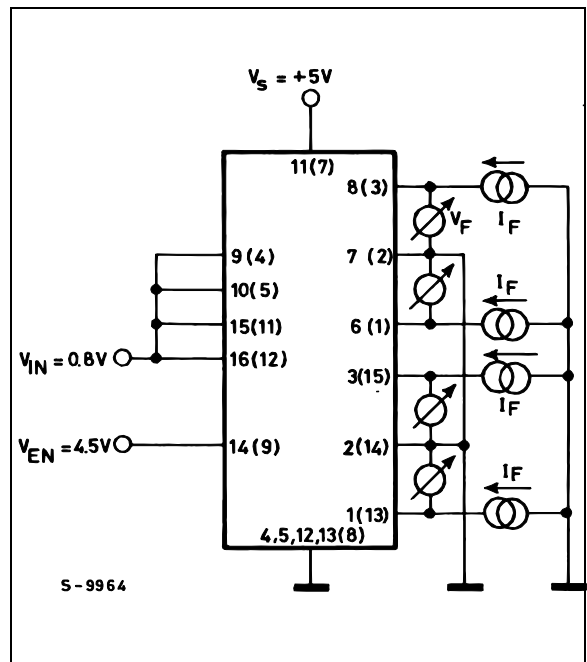

Figure 8 : Switching Times Test Circuit.

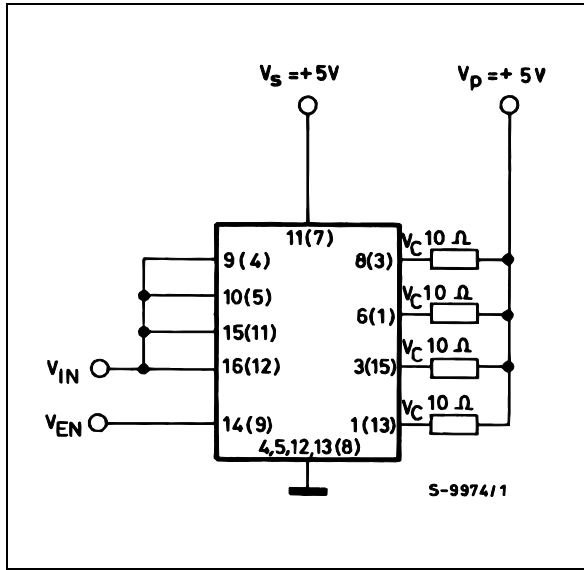

Figure 9 : Switching Times Waveforms.

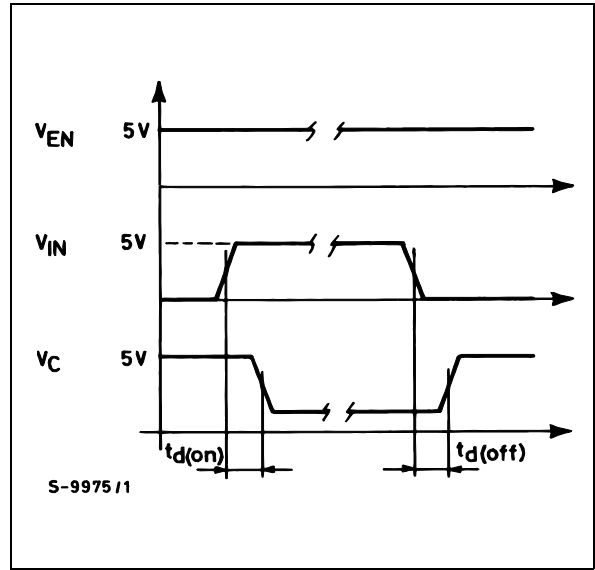

Figure 10 : Allowed Peak Collector Current vs. Duty Cycle for 1, 2, 3 or 4 Contemporary Working Outputs (L6221C).

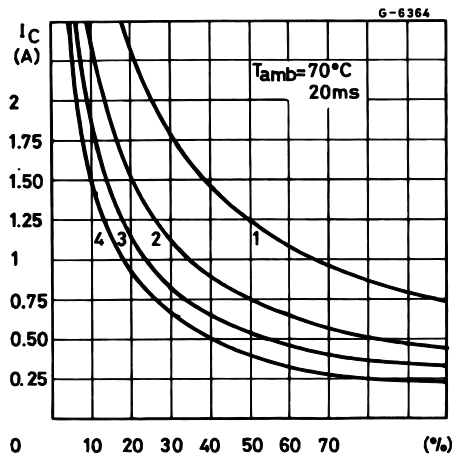

Figure 11 : Allowed Peak Collector Current vs. Duty Cycle for 1, 2, 3 or 4 Contemporary Working Outputs (L6221CN).

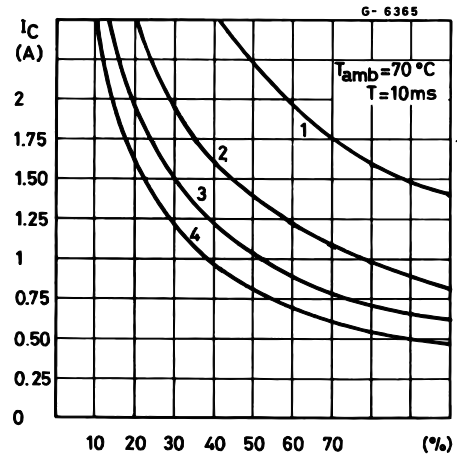

Figure 12 : Collector Saturation Voltage vs. Collector Current.

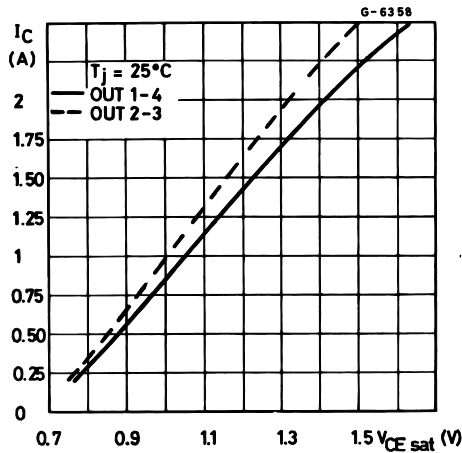

Figure 13 : Free-wheeling Diode Forward Voltage vs. Diode Current .

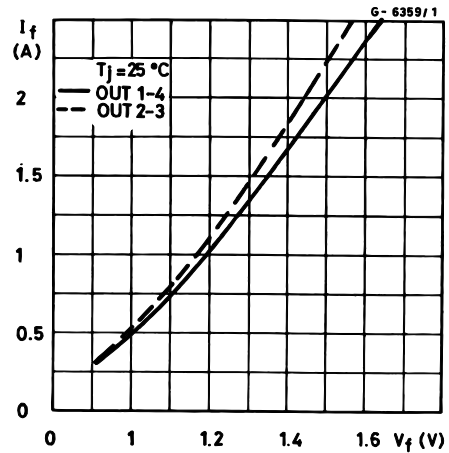

Figure 14 : Collector Saturation Voltage vs. Junction Temperature at $I_C = 1\text{A}$.

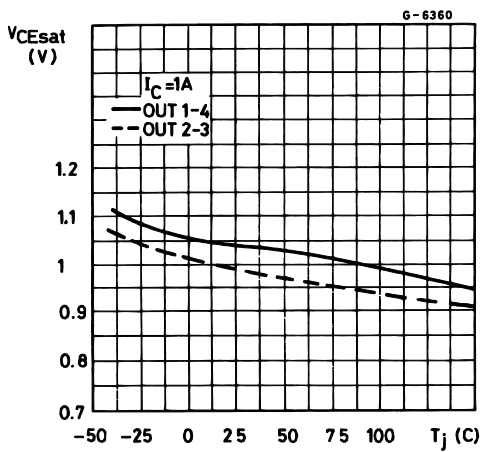

Figure 15 : Free-wheeling Diode Forward Voltage vs. Junction Temperature at $I_f = 1\text{A}$.

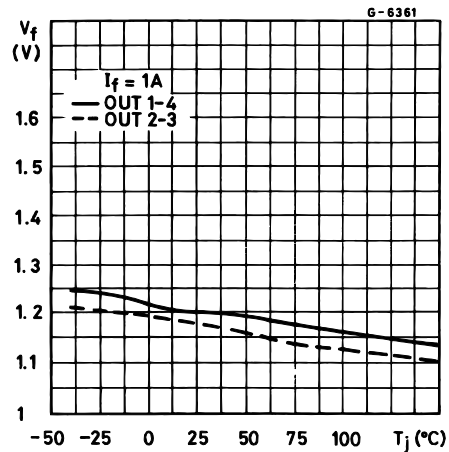

Figure 16 : Saturation Voltage vs. Junction Temperature at $I_C = 1.8\text{A}$.

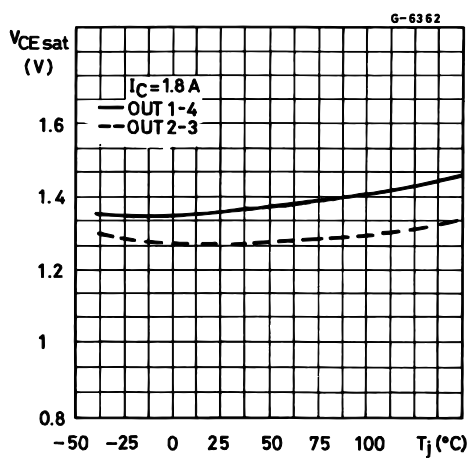

Figure 17 : Free-wheeling Diode Forward Voltage vs. Junction Temperature at $I_f = 1.8\text{A}$.

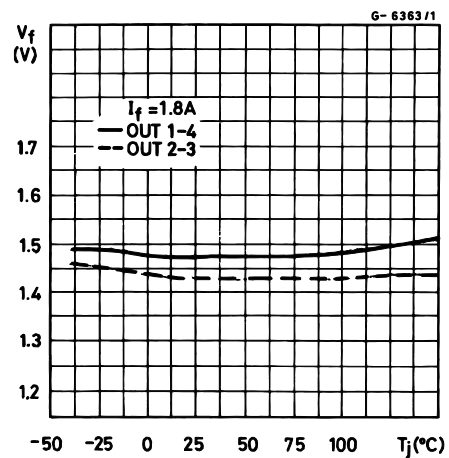
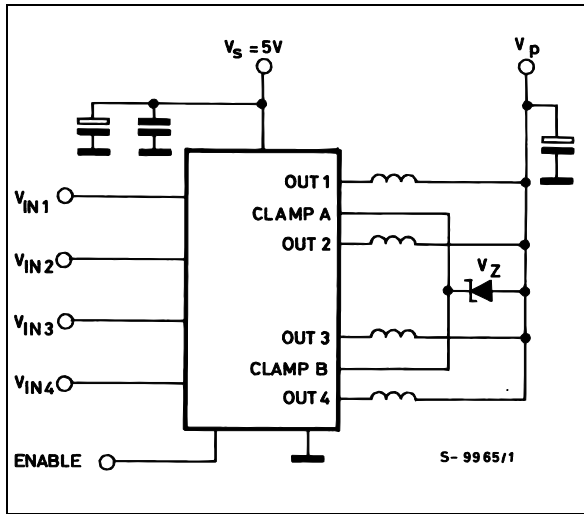

Figure 18.



APPLICATION INFORMATION

When inductive loads are driven by L6221C/CD, a zener diode in series with the integral free-wheeling diodes increases the voltage across which energy stored in the load is discharged and therefore speeds the current decay (fig. 18).

The zener has to be chosen in such a way that V_{CLAMP} is limited to 60V taking into account the zener's voltage changes due to: spread on V_z , temperature changes, and the voltage drop due to ohmic resistance.

Moreover, the instantaneous power must be limited in order to avoid the reverse second breakdown.

Figure 19 : Driver for Solenoids up to 3A.

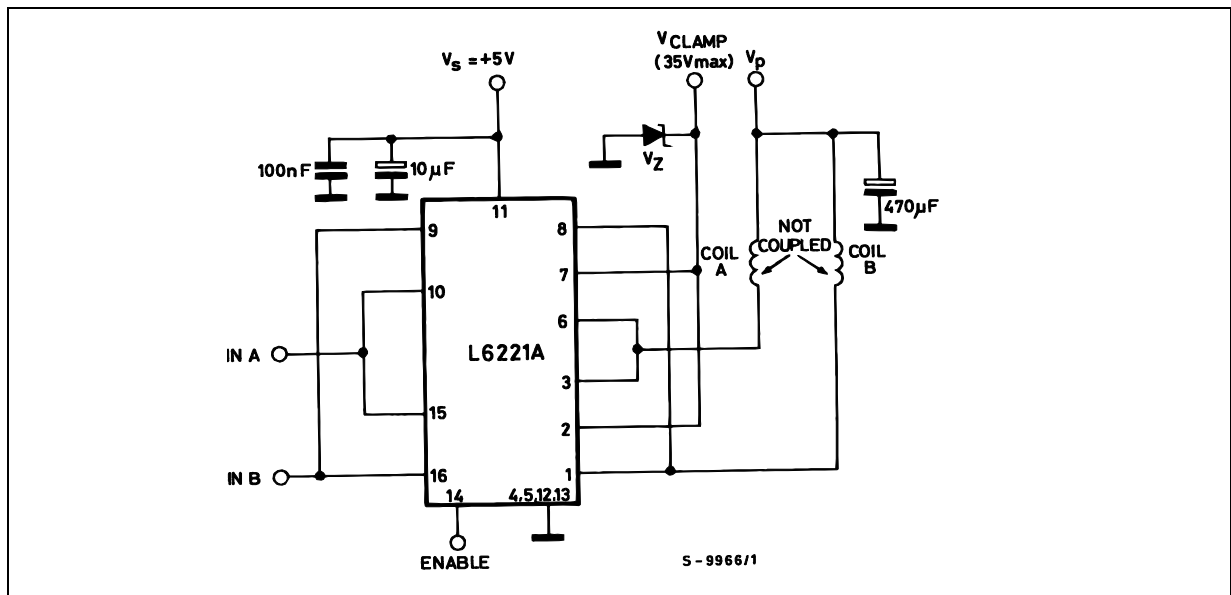

Some care must be taken to ensure that the collectors are placed close together to avoid different current partitioning at turn-off.

We suggest to put in parallel channel 1 and 4 and channel 2 and 3 as shown in figure 19 for the similar

electrical characteristics of the logic section (turn-on and turn-off delay time) and the power stages (collector saturation voltage, free-wheeling diode forward voltage).

Figure 20 : Saturation Voltage vs. Collector Current.

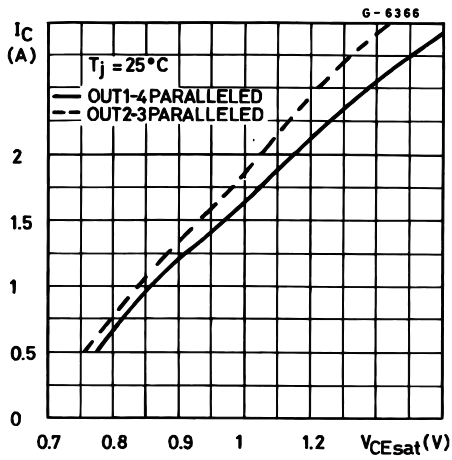

Figure 21 : Peak Collector Current vs. Duty Cycle for 1 or 2 Paralleled Outputs Driven (L6221N).

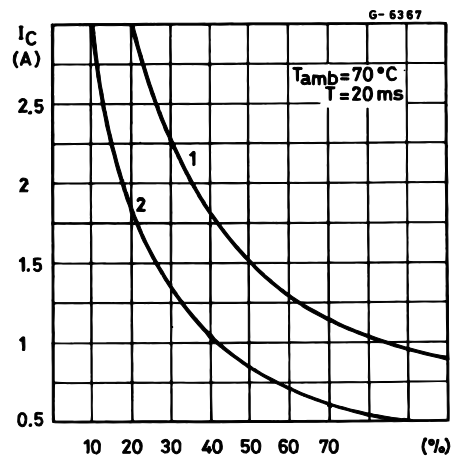
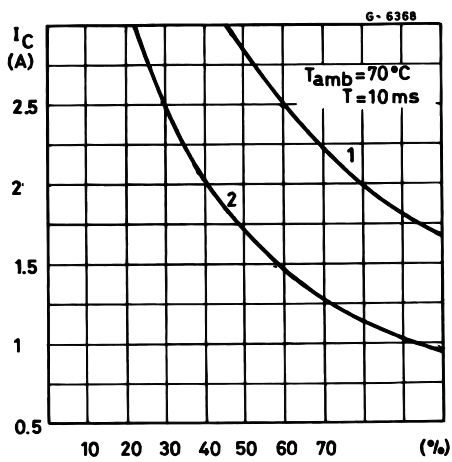

Figure 22 : Peak Collector Current vs. Duty Cycle for 1 or 2 Paralleled Outputs Driven (L6221CN).



MOUNTING INSTRUCTION

The $R_{th\ j-amb}$ of the L6221C can be reduced by soldering the GND pins to a suitable copper area of the printed circuit board (Fig. 23) or to an external heatsink (Fig. 24).

The diagram of figure 25 shows the maximum dissippable power P_{tot} and the $R_{th\ j-amb}$ as a function of the side " α " of two equal square copper areas hav-

ing a thickness of 35μ (1.4 mils). During soldering the pins temperature must not exceed $260\text{ }^\circ\text{C}$ and the soldering time must not be longer than 12 seconds.

The external heatsink or printed circuit copper area must be connected to electrical ground.

Figure 23 : Example of P.C. Board Copper Area Which is Used as Heatsink.

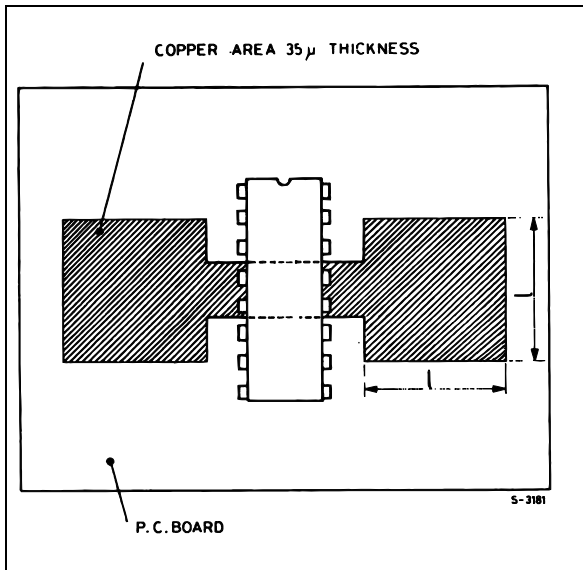

Figure 24 : External Heatsink Mounting Example.

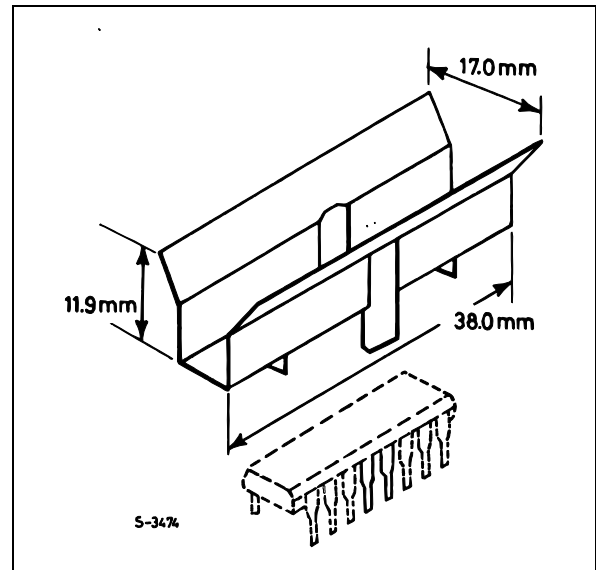

Figure 25 : Maximum Dissippable Power and Junction to Ambient Thermal Resistance vs. Side " α ".

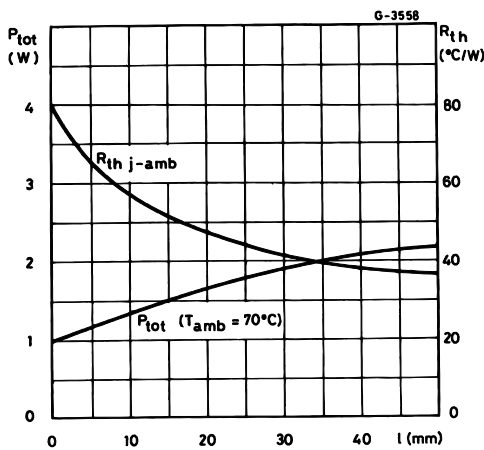
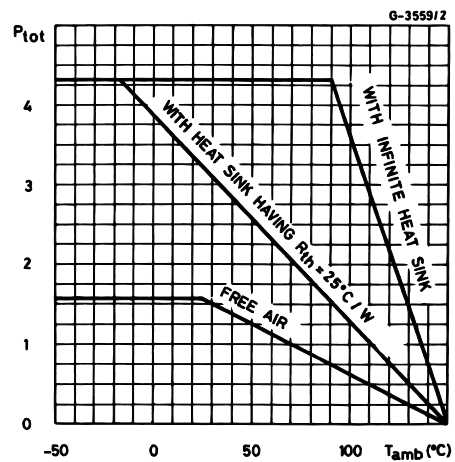

Figure 26 : Maximum Allowable Power Dissipation vs. Ambient Temperature.



L6221C

DIM.	mm			inch		
	MIN.	TYP.	MAX.	MIN.	TYP.	MAX.
A			5			0.197
B			2.65			0.104
C			1.6			0.063
D		1			0.039	
E	0.49		0.55	0.019		0.022
F	0.66		0.75	0.026		0.030
G	1.02	1.27	1.52	0.040	0.050	0.060
G1	17.53	17.78	18.03	0.690	0.700	0.710
H1	19.6			0.772		
H2			20.2			0.795
L	21.9	22.2	22.5	0.862	0.874	0.886
L1	21.7	22.1	22.5	0.854	0.870	0.886
L2	17.65		18.1	0.695		0.713
L3	17.25	17.5	17.75	0.679	0.689	0.699
L4	10.3	10.7	10.9	0.406	0.421	0.429
L7	2.65		2.9	0.104		0.114
M	4.25	4.55	4.85	0.167	0.179	0.191
M1	4.63	5.08	5.53	0.182	0.200	0.218
S	1.9		2.6	0.075		0.102
S1	1.9		2.6	0.075		0.102
Dia1	3.65		3.85	0.144		0.152

OUTLINE AND MECHANICAL DATA

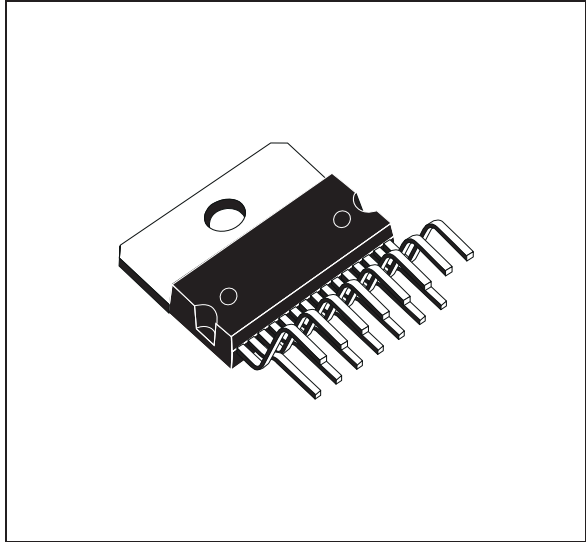

Multiwatt15 V

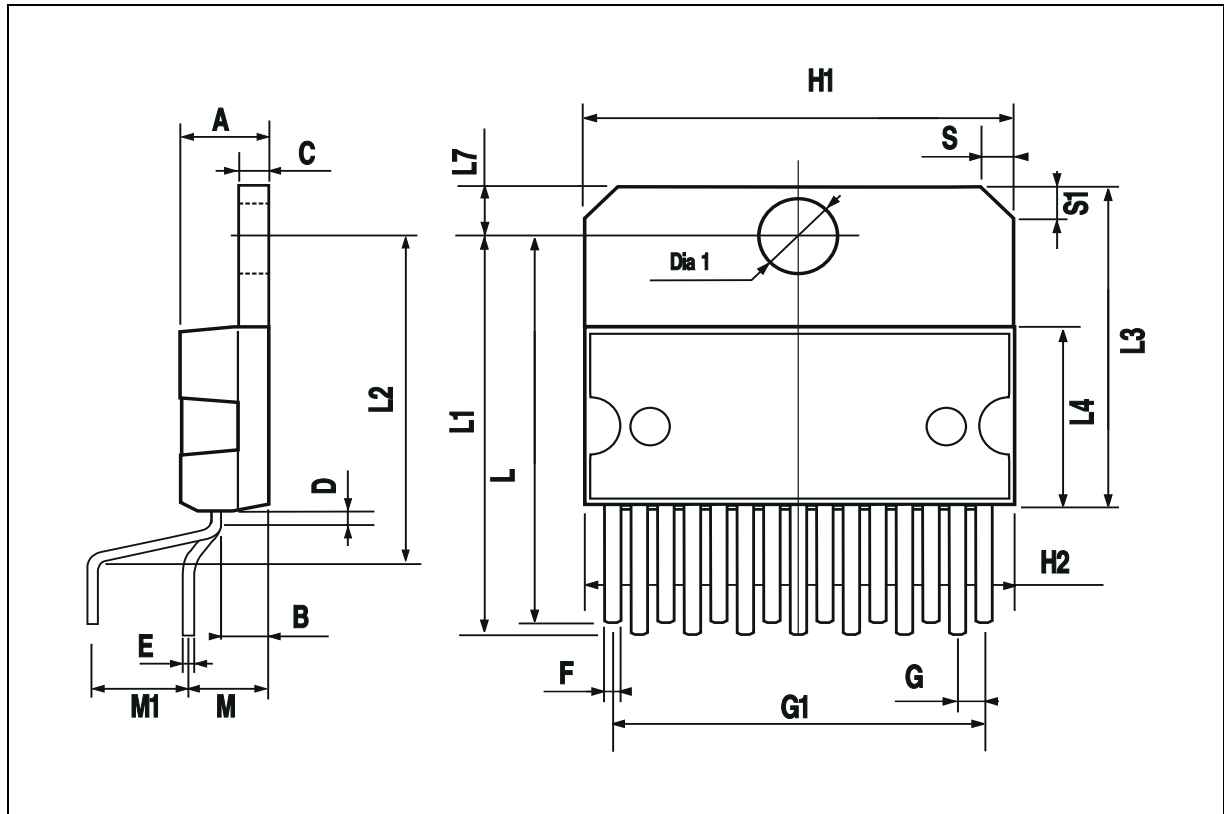

DIM.	mm			inch		
	MIN.	TYP.	MAX.	MIN.	TYP.	MAX.
a1	0.51			0.020		
B	0.85		1.40	0.033		0.055
b		0.50			0.020	
b1	0.38		0.50	0.015		0.020
D			20.0			0.787
E		8.80			0.346	
e		2.54			0.100	
e3		17.78			0.700	
F			7.10			0.280
I			5.10			0.201
L		3.30			0.130	
Z			1.27			0.050

OUTLINE AND MECHANICAL DATA

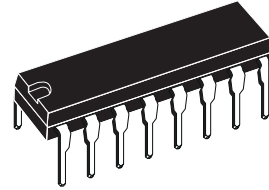

Powerdip 16

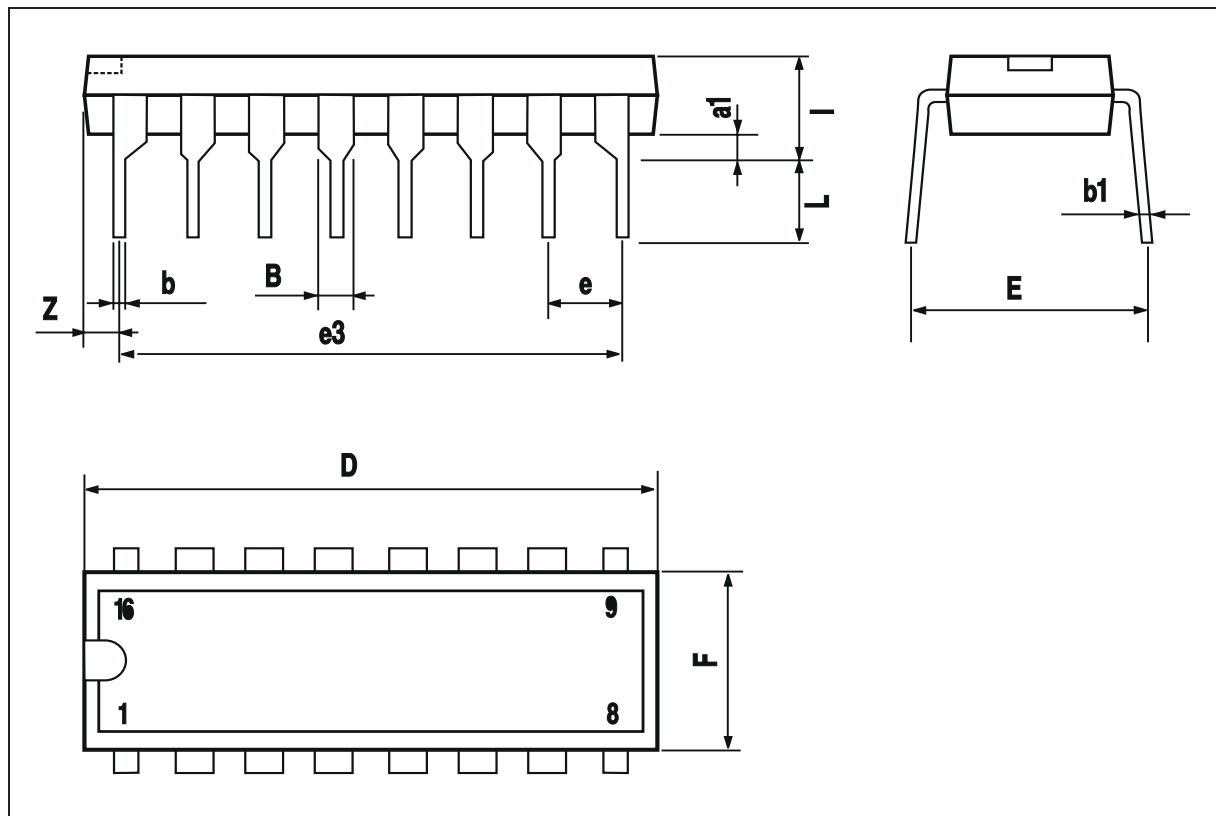

L6221C

DIM.	mm			inch		
	MIN.	TYP.	MAX.	MIN.	TYP.	MAX.
A	2.35		2.65	0.093		0.104
A1	0.1		0.3	0.004		0.012
B	0.33		0.51	0.013		0.020
C	0.23		0.32	0.009		0.013
D	12.6		13	0.496		0.512
E	7.4		7.6	0.291		0.299
e		1.27			0.050	
H	10		10.65	0.394		0.419
h	0.25		0.75	0.010		0.030
L	0.4		1.27	0.016		0.050
K	0° (min.)8° (max.)					

OUTLINE AND MECHANICAL DATA

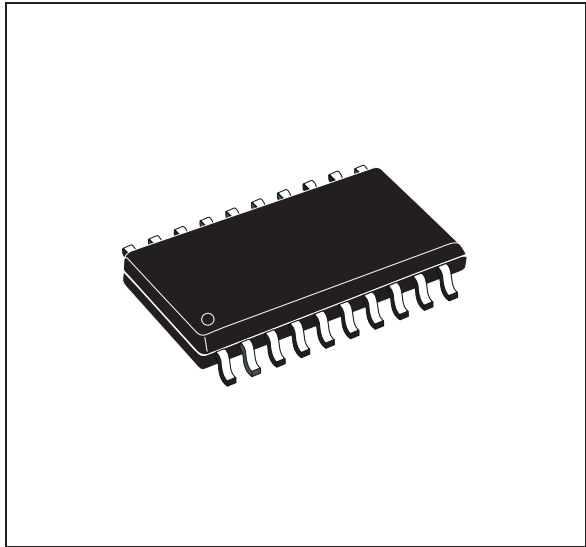

SO20

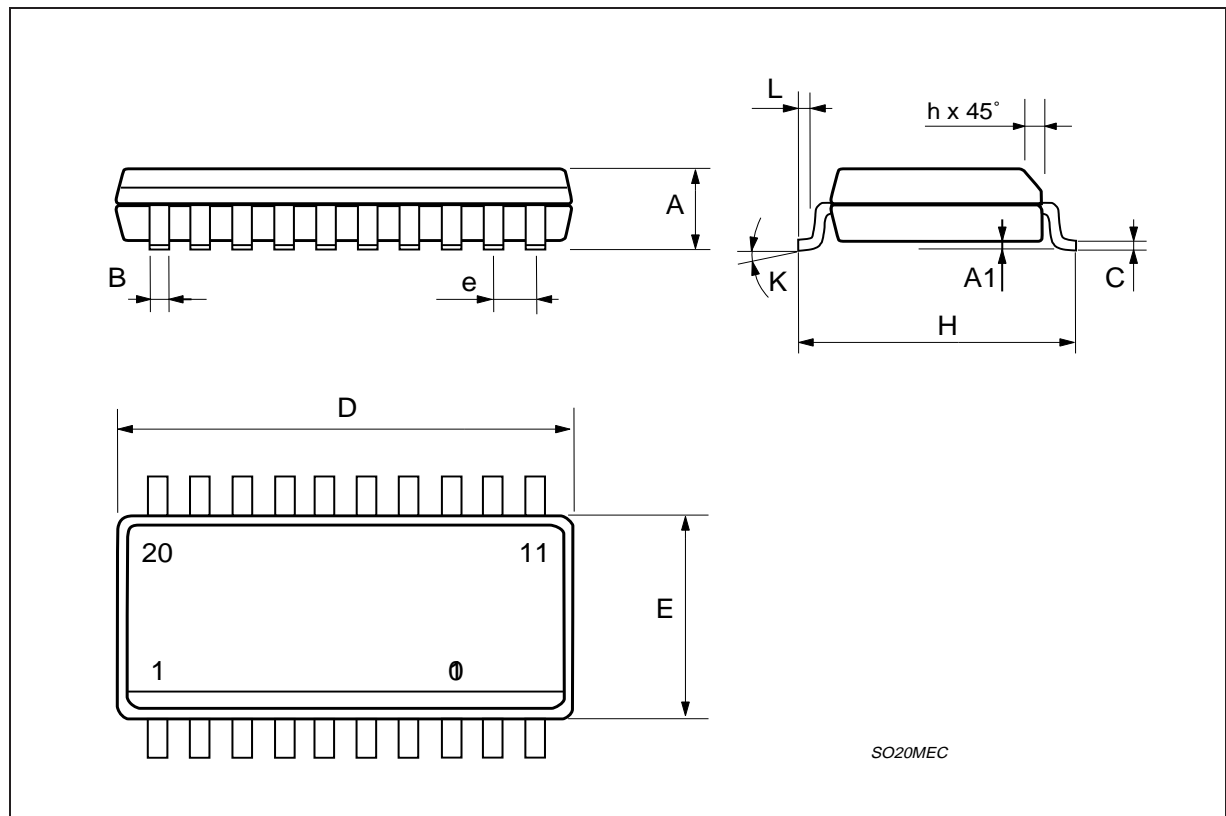

Information furnished is believed to be accurate and reliable. However, STMicroelectronics assumes no responsibility for the consequences of use of such information nor for any infringement of patents or other rights of third parties which may result from its use. No license is granted by implication or otherwise under any patent or patent rights of STMicroelectronics. Specification mentioned in this publication are subject to change without notice. This publication supersedes and replaces all information previously supplied. STMicroelectronics products are not authorized for use as critical components in life support devices or systems without express written approval of STMicroelectronics.

The ST logo is a registered trademark of STMicroelectronics
© 2003 STMicroelectronics – Printed in Italy – All Rights Reserved
STMicroelectronics GROUP OF COMPANIES

Australia - Brazil - Canada - China - Finland - France - Germany - Hong Kong - India - Israel - Italy - Japan - Malaysia - Malta - Morocco - Singapore - Spain - Sweden - Switzerland - United Kingdom - United States.

<http://www.st.com>