

V2406A Series

Intel® 3rd Gen Core™ CPU, EN 50155 railway computer



Features and Benefits

- Intel Celeron/Core i7 processor
- Dual independent DVI-I displays
- 2 Gigabit Ethernet ports with M12 X-coded connectors
- 1 SATA connector and 2 CFast sockets for storage expansion
- M12 A-coded power connector
- Compliant with EN 50121-4
- Complies with all EN 50155 mandatory test items¹
- Ready-to-run Debian 7, Windows Embedded Standard 7, and Windows 10 Embedded IoT Enterprise 2016 LTSB platforms
- -40 to 70°C wide-temperature models available
- Supports SNMP-based system configuration, control, and monitoring (Windows only)

Certifications



EN 50155



EN 50121-4



Introduction

The V2406A Series embedded computers are based on the Intel 3rd Gen processor, and feature 4 RS-232/422/485 serial ports, dual LAN ports, audio in/out, 3 USB 2.0 hosts, 2 CFast sockets, and 1 SATA storage socket. The V2406A computers provide dual DVI-I outputs, and in addition are compliant with the mandatory test items of the EN 50155 standard, making the computers suitable for a variety of industrial applications.

The dual megabit/Gigabit Ethernet ports with M12 X-coded connectors offer a reliable solution for network redundancy, promising continuous operation for data communication and management. As an added convenience, the V2406A computers have 6 DIs and 2 DOs for connecting digital input/output devices, and the CFast feature provides the reliability needed for industrial applications that require data buffering and storage expansion.

Preinstalled with Linux Debian 7 or Windows Embedded Standard 7, the V2406A Series provides programmers with a friendly environment for developing sophisticated, bug-free application software at a low cost. Wide-temperature models of the V2406A Series that operate reliably in a -40 to 70°C operating temperature range are also available, offering an optimal solution for applications subjected to harsh environments.

1. This product is suitable for rolling stock railway applications, as defined by the EN 50155 standard. For a more detailed statement, click here: www.moxa.com/doc/specs/EN_50155_Compliance.pdf

Appearance

Front View

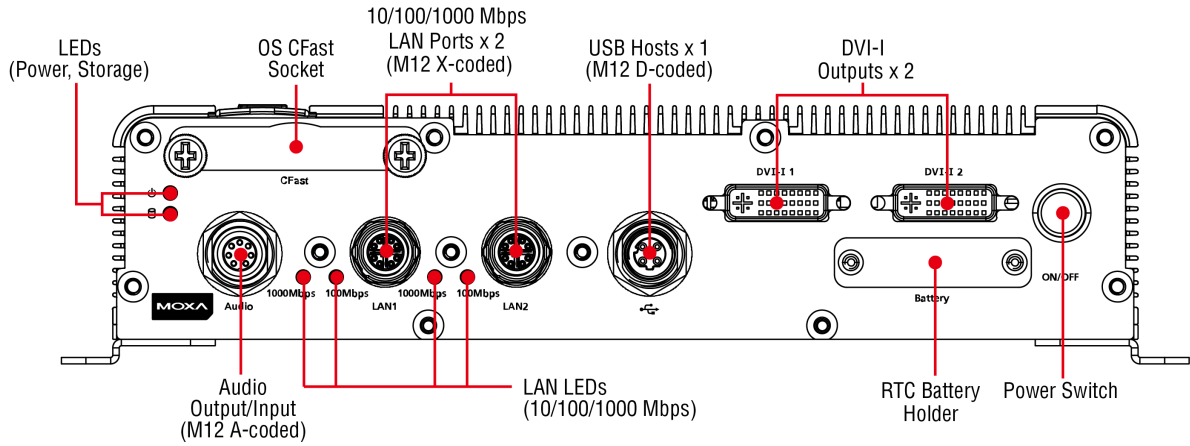

Rear View

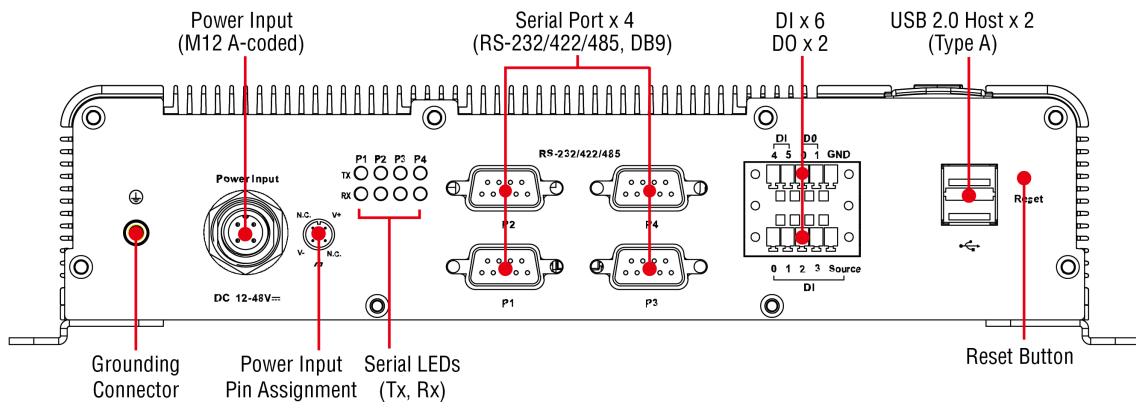

Specifications

Computer

CPU	V2406A-C2 Series: Intel® Celeron® Processor 1047UE (2 M cache, 1.40 GHz) V2406A-C7 Series: Intel® Core™ i7-3517UE Processor (4 M cache, up to 2.80 GHz)
System Chipset	Mobile Intel® HM65 Express Chipset
Graphics Controller	Intel® HD Graphics 4000 (integrated)
System Memory Pre-installed	4 GB DDR3
System Memory Slot	SODIMM DDR3/DDR3L slot x 1
Supported OS	Linux Debian 7 Windows Embedded Standard 7 (WS7E) 32-bit Windows Embedded Standard 7 (WS7E) 64-bit
Storage Slot	2.5-inch HDD/SSD slots x 1 CFast slot x 2

Computer Interface

Ethernet Ports	Auto-sensing 10/100/1000 Mbps ports (M12 X-coded) x 2
Serial Ports	RS-232/422/485 ports x 4, software selectable (DB9 male)
USB 2.0	USB 2.0 hosts x 1, M12 D-coded connector USB 2.0 hosts x 2, type-A connectors
Audio Input/Output	Line in x 1, Line out x 1, M12 D-coded

Digital Input	DIs x 6
Digital Output	DOs x 2
Video Output	DVI-I x 2, 29-pin DVI-I connectors (female)

Digital Inputs

Isolation	3k VDC
Connector	Screw-fastened Euroblock terminal
Dry Contact	On: short to GND Off: open
I/O Mode	DI
Sensor Type	Dry contact Wet contact (NPN or PNP)
Wet Contact (DI to COM)	On: 10 to 30 VDC Off: 0 to 3 VDC

Digital Outputs

Connector	Screw-fastened Euroblock terminal
Current Rating	200 mA per channel
I/O Type	Sink
Voltage	24 to 30 VDC

LED Indicators

System	Power x 1 Storage x 1
LAN	2 per port (10/100/1000 Mbps)
Serial	2 per port (Tx, Rx)

Serial Interface

Baudrate	50 bps to 921.6 kbps
Flow Control	RTS/CTS, XON/XOFF, ADDC® (automatic data direction control) for RS-485, RTS Toggle (RS-232 only)
Parity	None, Even, Odd, Space, Mark
Data Bits	5, 6, 7, 8
Stop Bits	1, 1.5, 2

Serial Signals

RS-232	TxD, RxD, RTS, CTS, DTR, DSR, DCD, GND
RS-422	Tx+, Tx-, Rx+, Rx-, GND
RS-485-2w	Data+, Data-, GND
RS-485-4w	Tx+, Tx-, Rx+, Rx-, GND

Power Parameters

Input Voltage	12 to 48 VDC
Power Connector	M12 A-coded male connector
Power Consumption (Max.)	3.3 A @ 12 VDC 0.82 A @ 48 VDC
Power Consumption	40 W (max.)

Physical Characteristics

Housing	Aluminum
IP Rating	IP30
Dimensions (with ears)	275 x 63 x 154 mm (10.83 x 2.47 x 6.06 in)
Dimensions (without ears)	250 x 57 x 154 mm (9.84 x 2.23 x 6.06 in)
Weight	2,000 g (4.44 lb)
Installation	DIN-rail mounting (optional), Wall mounting (standard)
Protection	V2406A-C2-CT-T/C7-CT-T: PCB conformal coating

Environmental Limits

Operating Temperature	Standard Models: -25 to 55°C (-13 to 131°F) Wide Temp. Models: -40 to 70°C (-40 to 158°F)
Storage Temperature (package included)	-40 to 85°C (-40 to 185°F)
Ambient Relative Humidity	5 to 95% (non-condensing)

Standards and Certifications

EMC	EN 55032/24
EMI	CISPR 32, FCC Part 15B Class A
EMS	IEC 61000-4-2 ESD: Contact: 6 kV; Air: 8 kV IEC 61000-4-3 RS: 80 MHz to 1 GHz: 20 V/m IEC 61000-4-4 EFT: Power: 2 kV; Signal: 2 kV IEC 61000-4-5 Surge: Power: 2 kV IEC 61000-4-6 CS: 10 V IEC 61000-4-8 PFMF
Railway	EN 50121-4, IEC 60571
Railway Fire Protection	EN 45545-2
Safety	EN 60950-1, UL 60950-1
Shock	IEC 60068-2-27, IEC 61373, EN 50155
Vibration	IEC 60068-2-64, IEC 61373, EN 50155

Declaration

Green Product	RoHS, CRoHS, WEEE
---------------	-------------------

MTBF

Time	332,173 hrs
Standards	Telcordia (Bellcore), GB

Warranty

Warranty Period	3 years
Details	See www.moxa.com/warranty

Package Contents

Device	1 x V2406A Series computer
Installation Kit	1 x wall-mounting kit
Documentation	1 x document and software CD 1 x quick installation guide 1 x warranty card

Dimensions

Unit: mm (inch)

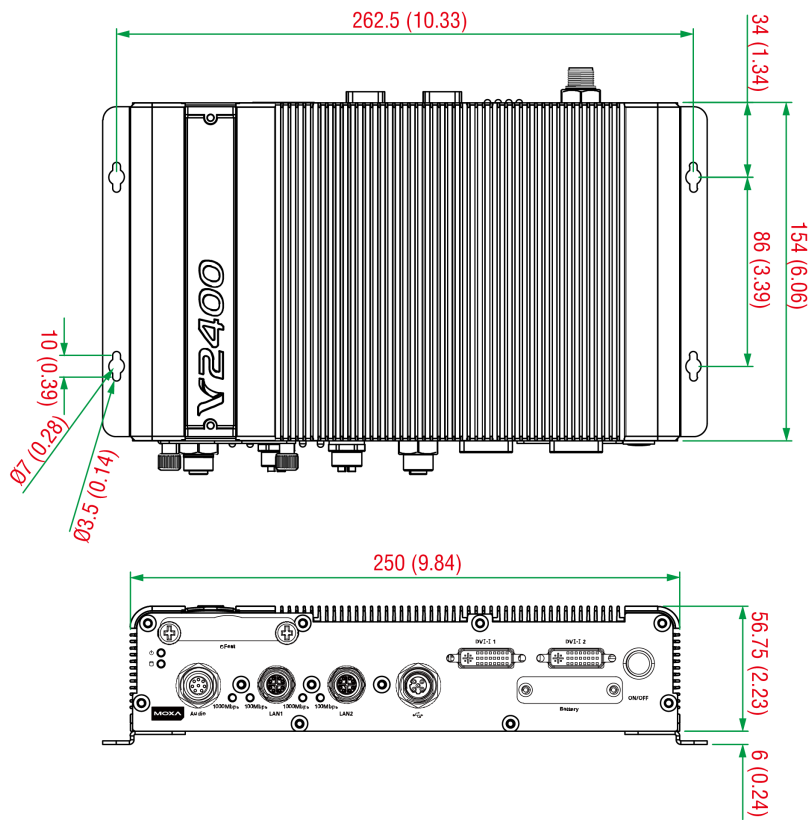

Ordering Information

Model Name	CPU	Memory (Default)	OS CFast (CTO)	Backup CFast (CTO)	SSD/HDD Tray (CTO)	Operating Temp.	Conformal Coating
V2406A-C2	Celeron 1047UE	4 GB	1 (Optional)	1 (Optional)	1 (Optional)	-25 to 55°C	-
V2406A-C2-T	Celeron 1047UE	4 GB	1 (Optional)	1 (Optional)	1 (Optional)	-40 to 70°C	-
V2406A-C2-CT-T	Celeron 1047UE	4 GB	1 (Optional)	1 (Optional)	1 (Optional)	-40 to 70°C	✓
V2406A-C7	Core i7-3517UE	4 GB	1 (Optional)	1 (Optional)	1 (Optional)	-25 to 55°C	-
V2406A-C7-T	Core i7-3517UE	4 GB	1 (Optional)	1 (Optional)	1 (Optional)	-40 to 70°C	-
V2406A-C7-CT-T	i7-3517UE	4 GB	1 (Optional)	1 (Optional)	1 (Optional)	-40 to 70°C	✓
V2406A-C2-W7E	Celeron 1047UE	4 GB	8 GB	1 (Optional)	1 (Optional)	-25 to 55°C	-

Model Name	CPU	Memory (Default)	OS CFast (CTO)	Backup CFast (CTO)	SSD/HDD Tray (CTO)	Operating Temp.	Conformal Coating
V2406A-C2-T-W7E	Celeron 1047UE	4 GB	8 GB	1 (Optional)	1 (Optional)	-40 to 70°C	-
V2406A-C7-T-W7E	i7-3517UE	4 GB	8 GB	1 (Optional)	1 (Optional)	-40 to 70°C	-

Accessories (sold separately)

Battery Kits

RTC Battery Kit	Lithium battery with built-in connector
-----------------	---

Cables

CBL-M12(FF5P)/Open-100 IP67	A-coded M12-to-5-pin power cable, IP67-rated 5-pin female M12 connector, 1 m
CBL-M12XMM8PRJ45-BK-100-IP67	M12-to-RJ45 Cat-5E UTP gigabit Ethernet cable, 8-pin X-coded male connector, IP67, 1 m

Connectors

M12A-5PMM-IP68	5-pin male circular threaded D-coded M12 USB connector, IP68
M12X-8PMM-IP67	8-pin male X-coded circular threaded gigabit Ethernet connector, IP67
M12A-5P-IP68	A-coded screw-in sensor connector, female, IP68, 4.05 cm
M12A-8PMM-IP67	8-pin male circular threaded A-codes M12 connector, IP67-rated (for field-installation)

Power Adapters

PWR-24270-DT-S1	Power adapter, input voltage 90 to 264 VAC, output voltage 24 V with 2.5 A DC load
-----------------	--

Power Cords

PWC-C7AU-2B-183	Power cord with Australian (AU) plug, 2.5A/250V, 1.83 m
PWC-C7CN-2B-183	Power cord with two-prong China (CN) plug, 1.83 m
PWC-C7EU-2B-183	Power cord with Continental Europe (EU) plug, 2.5A/250V, 1.83 m
PWC-C7UK-2B-183	Power cord with United Kingdom (UK) plug, 2.5A/250V, 1.83 m
PWC-C7US-2B-183	Power cord with United States (US) plug, 10A/125V, 1.83 m

Antennas

ANT-WDB-ANF-0407	2.4/5 GHz, omni-directional antenna, 4/7 dBi, N-type (male)
------------------	---

Wall-Mounting Kits

V2400 Isolated Wall Mount Kit	Wall-mounting kit with isolation protection, 2 wall-mounting brackets, 4 screws
-------------------------------	---

Storage Kits

FK-75125-02	Storage bracket, 4 large silver screws, 4 soft washers, 4 small silver bronze screws, 1 SATA power cable, 4 golden spacers (only for the V2406 and V2426)
-------------	---

DIN-Rail Mounting Kits

DK-DC50131	DIN-rail mounting kit, 6 screws
------------	---------------------------------

© Moxa Inc. All rights reserved. Updated Jan 22, 2020.

This document and any portion thereof may not be reproduced or used in any manner whatsoever without the express written permission of Moxa Inc. Product specifications subject to change without notice. Visit our website for the most up-to-date product information.