



ATO25D1GA

3.3V 1G-BIT
Serial NAND Flash Memory with Quad SPI



Revision History

| Revision No. | History | Date | Remark |
|---------------------|--|-------------|---------------|
| 0.0 | Initial Draft | Sep.2012 | preliminary |
| 0.1 | 1. Add one page configuration (page 15) 2. Add OTP Protection Register (page 24) 3. Add Random Data-in Limitation (page 31) 4. Add NOP Description (page 41) 5. Correct the typo (page17; 7.2 Quad SPI Instructions) | Nov. 2012 | |
| 0.2 | Add operating temperature(page 46) | Apr. 2013 | |
| 0.3 | Add Package pin map (page 9) | July. 2013 | |
| 0.4 | Adjust Package(WSON / SOIC 300mil) Image (Page 9) | Aug. 2013 | |
| 0.5 | Add Industrial operating temperature (Page 39) | Sep. 2013 | |

FEATURES

GENERAL

Serial Peripheral Interface

- Mode 0 and Mode 3

Standard, Quad SPI

- Standard SPI : SCLK, CS#, SI, SO
- Quad SPI : SCLK, CS#, SIO0, SIO1, SIO2/W#, SIO3/Hold#

Single power supply operation

- Full voltage range: 2.7V to 3.6V read, erase and program operations

Organization

- Memory Cell Array : (128M + 4M) x Bytes
- Data Register : (2048 + 64) x Bytes

Automatic Program and Erase

- Page Program : (2048 + 64) x Bytes
- Block Erase : (128K + 4K) x Bytes = 64pages

Page Read Operation

- Page Size : (2048 + 64) Bytes
- Page Read(cell array to page buffer) : 25us(Max.)
- Serial Page Access : 104MHz, 133MHz(C_L=15pF)

Fast Write Cycle Time

- Program time : 200us(Typ.)
- Block Erase time : 2ms(Typ.)

Electronic Identification

- JEDEC standard 1-byte manufacturer ID and 1-byte device ID.

Copy-Back PROGRAM Operation

- Fast Page copy without external buffering

Security features

- OTP area, 16K bytes(8 pages)

Hardware Data Protection

- Program / Erase locked during Power transitions.
- W# pin works in conjunction with Status Register Bits to protect specified memory areas. Status Register Block Protection bits (BP2, BP1, BP0) in status register configure parts of memory as read-only

Data Integrity

- Endurance:100K Program/Erase Cycles
- Data Retention : 10 years

Error Management

- Internal ECC code generation
- 1bit/528byte ECC, 1NOP/528byte

Package

- 8-pad 8x6 WSON
- 16-pin SOIC 300 mil

Contents

| | |
|---|-----------|
| 1 General Description | 8 |
| 2 Signal Descriptions | 10 |
| 2.1 Serial Data output (SO) – SO1 | 10 |
| 2.2 Serial Data input (SI) – SIO0 | 10 |
| 2.3 Serial Clock (SCLK) | 10 |
| 2.4 Chip Select (CS#) | 10 |
| 2.5 Hold (HOLD#) – SIO3 | 10 |
| 2.6 Write Protect (W#) – SIO2 | 10 |
| 3 SPI modes | 11 |
| 4 Data Protection | 13 |
| 6 OTP Feature | 14 |
| 6 Memory Organization | 15 |
| 7 Function Description | 17 |
| 7.1 Standard SPI Instruction | 17 |
| 7.2 Quad SPI Instruction | 17 |
| 7.3 Hold Condition | 18 |
| 8 Instructions | 19 |
| 8.1 Write Enable (WREN) | 20 |
| 8.2 Write Disable (WRDI) | 21 |
| 8.3 Read Identification (RDID) | 22 |
| 8.4 Software Reset | 23 |
| 8.5 Feature Operation | 24 |
| 8.5.1 OIP bit | 24 |
| 8.5.2 WEL bit | 24 |
| 8.5.3 BP2, BP1, BP0 bits | 24 |
| 8.5.4 QE bit | 25 |
| 8.5.5 P_Fail bit | 25 |
| 8.5.6 E_Fail bit | 25 |
| 8.6 Page Read (13h) | 26 |



| | |
|---|-----------|
| 8.7 Page Program | 28 |
| 8.8 Random Data Program | 31 |
| 8.9 Copy Back Program | 33 |
| 8.10 Block Erase (D8h) | 34 |
| 9 Error Management | 35 |
| 10 Power-up and Power-down | 36 |
| 11 Initial delivery states | 38 |
| 12 Maximum rating. | 38 |
| 13 DC and AC parameters | 39 |
| 14 Package mechanical | 44 |
| 15 Part numbering | 46 |



List of tables

| | | |
|-----------|--|----|
| Table 1. | Signal names | 9 |
| Table 2. | Protected area sizes | 14 |
| Table 3. | Instruction set | 19 |
| Table 4. | Read Identification (RDID) data-out sequence | 22 |
| Table 5. | Status Registers. | 32 |
| Table 6. | Error Management Details | 32 |
| Table 7. | Power-up timing and Vwl threshold. | 37 |
| Table 8. | Absolute maximum ratings | 38 |
| Table 9. | Operating conditions | 39 |
| Table 10. | Data retention and endurance | 39 |
| Table 11. | AC measurement conditions. | 39 |
| Table 12. | Capacitance | 39 |
| Table 13. | DC characteristics | 40 |
| Table 14. | AC characteristics | 41 |
| Table 15. | Ordering Information | 46 |

List of figures

| | | |
|------------|---|----|
| Figure 1. | Logic diagram. | 8 |
| Figure 2. | 8 Pad 8X6 WSON / 16pin SOIC connections | 9 |
| Figure 3. | Bus Master and memory devices on the SPI bus. | 11 |
| Figure 4. | SPI modes supported. | 12 |
| Figure 5. | Memory Organization | 15 |
| Figure 6. | Block diagram. | 16 |
| Figure 7. | Hold Condition activation | 18 |
| Figure 8. | Write Enable (WREN) instruction sequence | 20 |
| Figure 9. | Write Disable (WRDI) instruction sequence | 21 |
| Figure 10. | Read Identification (RDID) instruction sequence and data-out sequence | 22 |
| Figure 11. | Reset Sequence | 23 |
| Figure 12. | Get Feature Timing | 25 |
| Figure 13. | Set Feature Timing | 25 |
| Figure 14. | Page Read (13h) instruction Timing | 26 |
| Figure 15. | Read From Page Buffer(03h/0Bh) instruction Timing | 27 |
| Figure 16. | Read From Page Buffer X4 (6Bh) instruction Timing | 27 |
| Figure 17. | Page Program Load (02h) instruction sequence | 28 |
| Figure 18. | Page Program Load X4 (32h) instruction sequence | 29 |
| Figure 19. | Page Program Execute (10h) instruction sequence | 30 |
| Figure 20. | Page Load Random Data (84h) instruction sequence | 31 |
| Figure 21. | Page Load Random Data X4 (34h) instruction sequence. | 32 |
| Figure 22. | Block Erase (D8h) instruction sequence. | 34 |
| Figure 23. | Power-up timing | 37 |
| Figure 24. | AC measurement I/O waveform | 39 |
| Figure 25. | Serial input timing | 42 |
| Figure 26. | Write Protect setup and hold timing | 42 |
| Figure 27. | Hold timing | 43 |
| Figure 28. | Output timing | 43 |
| Figure 29. | 8 Contact 8x6mm WSON body width, package outline | 44 |
| Figure 30. | 16 Pin SOIC 300 mils body width, package outline | 45 |

1. General Description

The ATO25D1GA is 1G-bit with spare 32Mbit capacity. The device is offered in 3.3V power supply. Its NAND cell provides the most cost-effective solution for the solid state mass storage market. The memory is divided into blocks that can be erased independently so it possible to preserve valid data while old data is erased. The device contains 1024 blocks, composed by 64 pages consisting in two NAND structures of 32series connected Flash Cells. A program operation can be performed in typical 200us on the 2048-bytes and an erase operation can be performed in typical 2ms on a 128K-bytes block. Data in the page can be read out at 25ns cycle time per byte. The on-chip write control automates all program and erase functions including pulse repetition, where required, and internal verification and margining of data. Even the write-intensive systems can take advantage of the ATO25D1GA's extended reliability of 100K program/erase cycles by providing ECC(Error Correction Code) with real time mapping-out algorithm.

ATO25D1GA features a serial peripheral interface and software protocol allowing operation on a simple 3-wire bus while it is in single I/O mode. The three signals are a clock input(SCLK), a serial data input(SI), and a serial data output(SO). Serial access to the device is enabled by CS# input. When it is in four I/O read mode, the SI pin, SO pin, WP# pin and HOLD# pin become SIO0 pin, SIO1 pin, SIO2 pin SIO3 pin for address/dummy bits input and data output. The copy back function allows the optimization of defective blocks management : when a page program operation fails the data can be directly programmed in another page inside the same array section without the time consuming serial data insertion phase. The ATO25D1GA is an optimum solution for large nonvolatile storage applications such as solid state file storage and other portable applications requiring non-volatility.

After program/erase command is issued, auto program/erase algorithms which program/erase and verify the specified page or sector/block locations will be executed. Up to 2Kbytes can be programmed at a time. Pages can be erased in groups of 128KB erase. To provide user with ease of interface, a status register is included to indicate the status of the chip. The status read command can be issued to detect completion status of a program or erase operation via OIP bit. Advanced security features enhance the protection and security functions, please see security features section for more details.

The ATO25D1GA supports JEDEC standard manufacturer and device identification with a 16Kbytes(8 pages) Secured OTP.

Figure 1. Logic Diagram

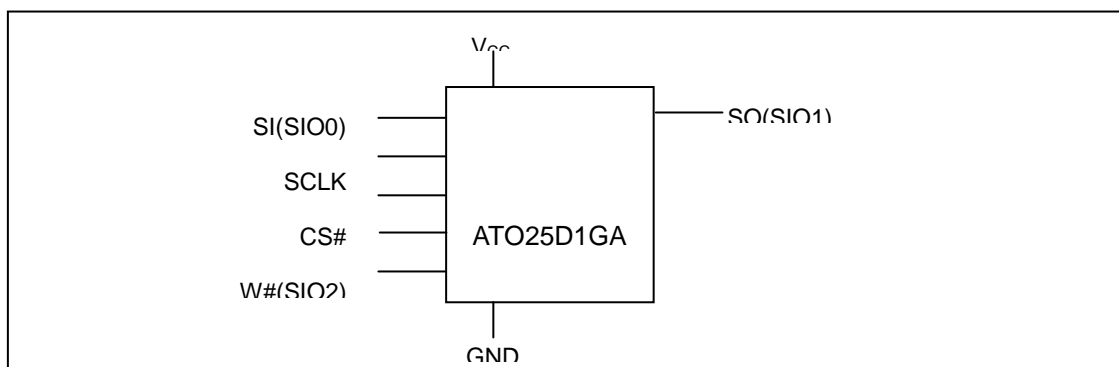
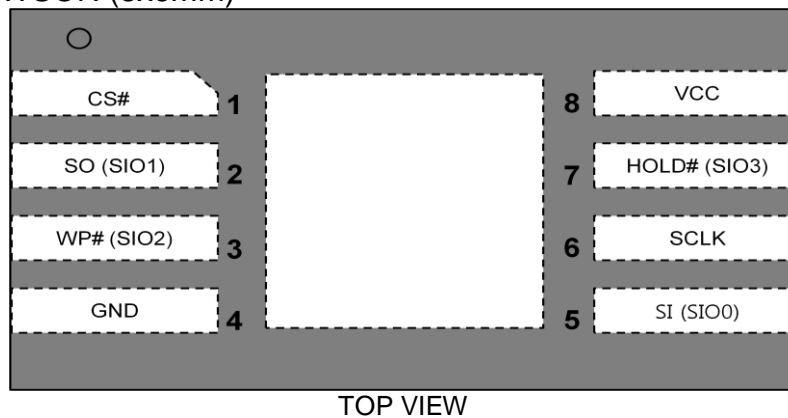

Table 1. Signal names

| Signal name | Function | Direction |
|-------------|--|----------------|
| SCLK | Serial Clock | Input |
| SI(SIO0) | Serial Data Input(for 1 I/O) Serial Data Input & Output(for 4 I/O) | Input / Output |
| SO(SIO1) | Serial Data Output(for 1 I/O) Serial Data Input & Output(for 4 I/O) | Input / Output |
| CS# | Chip Select | Input |
| W#(SIO2) | Write Protect Serial Data Input & Output(for 4 I/O) | Input / Output |
| HOLD#(SIO3) | Hold Serial Data Input & Output(for 4 I/O) | Input / Output |
| VCC | 3.3V Supply voltage | |
| GND | Ground | |

Figure 2. 8 Pad WSON 8x6mm / 16-Pin SOIC 300mil connections

8 Pad WSON (8x6mm)



16 Pin SOIC 300mil

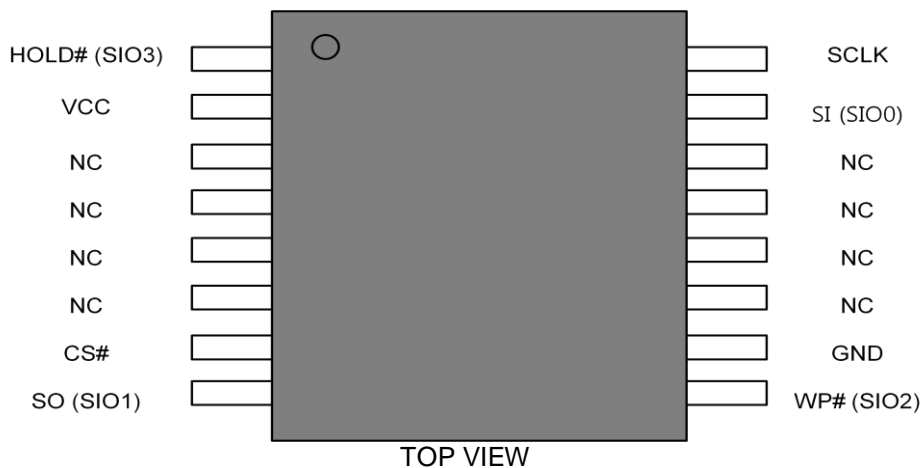

2 Signal descriptions

2.1 Serial Data output (SO) – SIO1

This output signal is used to transfer data serially out of the device. Data is shifted out on the falling edge of Serial Clock (SCLK) at all read mode. Also, When the device is Quad mode, this pin(SO) is used for SIO1

2.2 Serial Data input (SI) – SIO0

This input signal is used to transfer data serially into the device. It receives instructions, addresses, and the data to be programmed. Values are latched on the rising edge of Serial Clock (SCLK). Also, When the device is Quad mode, this pin(SI) is used for SIO0

2.3 Serial Clock (SCLK)

This input signal provides the timing of the serial interface. Instructions, addresses, or data present at Serial Data Input (SI) are latched on the rising edge of Serial Clock (SCLK). Data on Serial Data Output (SO) changes after the falling edge of Serial Clock (SCLK).

2.4 Chip Select (CS#)

When this input signal is High, the device is deselected and Serial Data Output Pins are at high impedance. Unless an internal Program, Erase or Write Status Register cycle is in progress, the device will be in the Standby mode (this is not the Deep Power-down mode). Driving Chip Select (CS#) Low enables the device, placing it in the active power mode.

After Power-up, a falling edge on Chip Select (CS#) is required prior to the start of any instruction.

2.5 Hold (HOLD#) – SIO3

The Hold (HOLD#) signal is used to pause any serial communications with the device without deselecting the device.

During the Hold condition, the Serial Data Output (SO) is high impedance, and Serial Data Input (SI) and Serial Clock (SCLK) are Don't Care.

To start the Hold condition, the device must be selected, with Chip Select (CS#) driven Low. Also, When the QE bit of Status Register is set for "High", the Hold# function is not available and this pin used for SIO3 in Quad mode.

2.6 Write Protect (W#) – SIO2

The main purpose of this input signal is to freeze the size of the area of memory that is protected against program or erase instructions (as specified by the values in the BP2, BP1 and BP0 bits of the Status Register).

Like the Hold# pin, When the QE bit of Status Register is set for "High", the W# function is not available too, and this pin used for SIO2 in Quad mode.

3 SPI modes

These devices can be driven by a microcontroller with its SPI peripheral running in either of the two following modes:

- CPOL=0, CPHA=0
- CPOL=1, CPHA=1

For these two modes, input data is latched in on the rising edge of Serial Clock (SCLK), and output data is available from the falling edge of Serial Clock (SCLK).

The difference between the two modes, as shown in *Figure 4*, is the clock polarity when the bus master is in Standby mode and not transferring data:

- C remains at 0 for (CPOL=0, CPHA=0)
- C remains at 1 for (CPOL=1, CPHA=1)

Figure 3. Bus Master and memory devices on the SPI bus

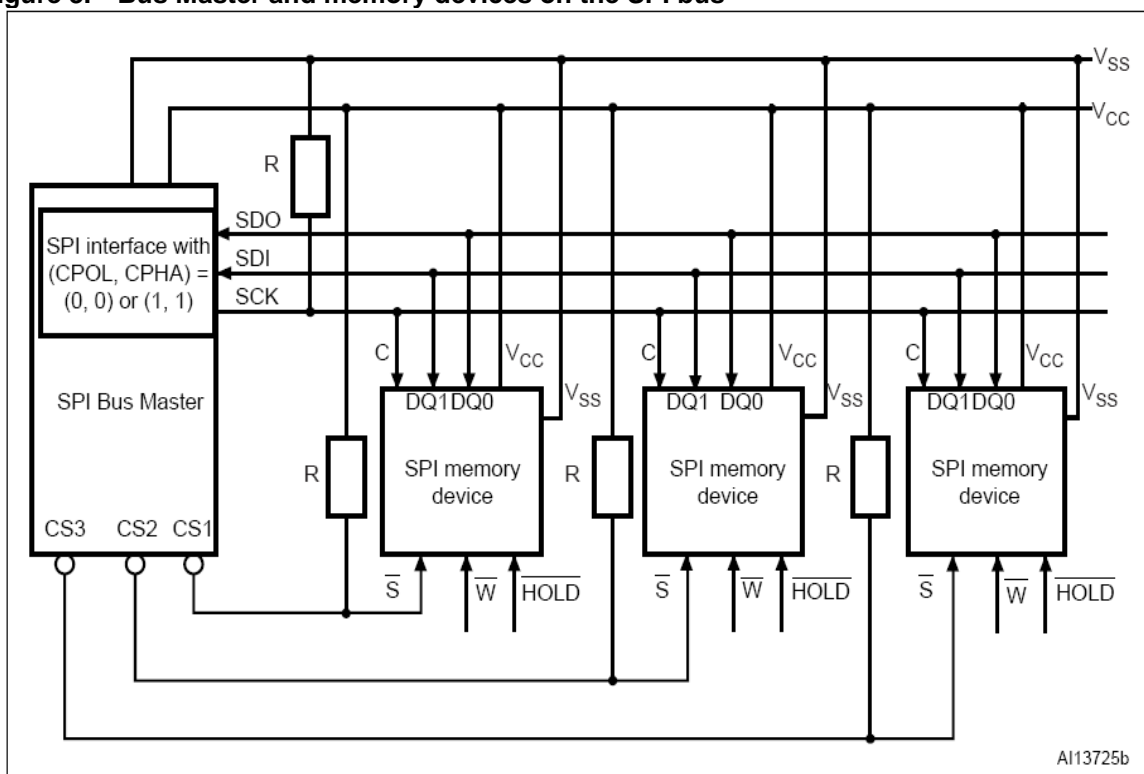

1. The Write Protect (W) and Hold (HOLD) signals should be driven, High or Low as appropriate.

Figure 3 shows an example of three devices connected to an MCU, on an SPI bus. Only one device is selected at a time, so only one device drives the Serial Data Output (SO) line at a time, the other devices are in the high impedance state. Resistors R (represented in *Figure 3*) ensure that the ATO25D1GA is not selected if the Bus Master leaves the CS# line in the high impedance state. As the Bus Master may enter a state where all inputs/outputs are in high impedance at the same time (for example, when the Bus Master is reset), the clock line (SCLK) must be connected to an external pull-down resistor so that, when all inputs/outputs become high impedance, the S line is pulled High while the SCLK line is pulled Low (thus ensuring that CS# and SCLK do not become High at the same time, and so, that the t_{SHCH} requirement is met). The typical value of R is 100 k Ω , assuming that the time constant $R \cdot C_p$ (C_p = parasitic capacitance of the bus line) is shorter than the time during which the Bus Master leaves the SPI bus in high impedance.

Example: $C_p = 50$ pF, that is $R \cdot C_p = 5$ μ s \Leftrightarrow the application must ensure that the Bus Master never leaves the SPI bus in the high impedance state for a time period shorter than 5 μ s.

Figure 4. SPI modes supported

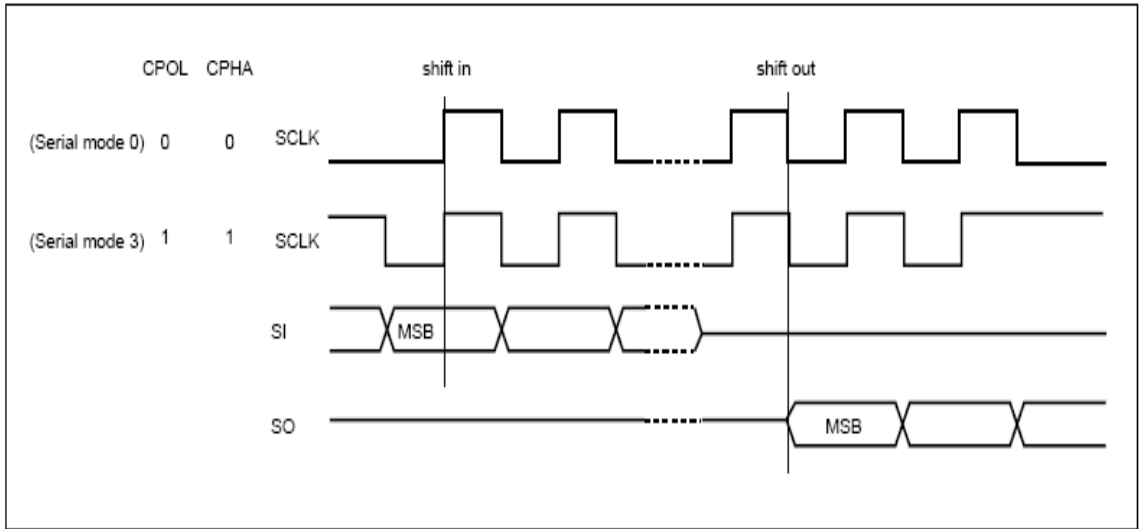

4 Data Protection

The environments where non-volatile memory devices are used can be very noisy. No SPI device can operate correctly in the presence of excessive noise. The block lock feature provides the ability to protect the entire device, or ranges of blocks, from the PROGRAM and ERASE operations. After power-up, the device is in the “locked” state, i.e., bits 3, 4, and 5 of the block lock register are set to 1. To unlock all the blocks, or a range of blocks, the SET FEATURES command must be issued with the A0h feature address, including the data bits shown in *Table 6.* The operation for the SET FEATURES command is shown in *Figure 13* on page 25. When BRWD is set and WP is LOW, none of the writable bits (3, 4, 5, and 7) in the block lock register can be set. Also, when a PROGRAM/ERASE command is issued to a locked block, a status of C0h is returned. When an ERASE command is issued to a locked block, the erase failure, 04h, is returned. When a PROGRAM command is issued to a locked block, program failure, 08h, is returned.

Table 2. Protected area sizes

| BP2 | BP1 | BP0 | Protected Rows |
|-----|-----|-----|----------------------|
| 0 | 0 | 0 | None-all unlocked |
| 0 | 0 | 1 | Upper 1/64 locked |
| 0 | 1 | 0 | Upper 1/32 locked |
| 0 | 1 | 1 | Upper 1/16 locked |
| 1 | 0 | 0 | Upper 1/8 locked |
| 1 | 0 | 1 | Upper 1/4 locked |
| 1 | 1 | 0 | Upper 1/2 locked |
| 1 | 1 | 1 | All locked (default) |

For example, if all the blocks need to be unlocked after power-up, the following sequence should be performed:

1. Issue SET FEATURES register write (1Fh)
2. Issue the feature address to unlock the block (A0h)
3. Issue 00h on data bits to unlock all blocks



5 OTP Feature

Additional 16K-byte secured OTP for unique identifier to provide 16K-byte one-time program area for setting device unique serial number – Which may be set by factory or system customer.

The serial device offers a protected, one-time programmable NAND Flash memory area. Ten full pages (2112 bytes per page) are available on the device, and the entire range is guaranteed to be good. Customers can use the OTP area any way they want; typical uses include programming serial numbers, or other data, for permanent storage. To access the OTP feature, the user must issue the SET FEATURES command, followed by feature address B0h. When the OTP is ready for access, pages 02h–09h can be programmed in sequential order. The PROGRAM LOAD (02h) and PROGRAM EXECUTE(10h) commands can be used to program the pages. Also, the PAGE READ (13h) command can be used to read the OTP area. The data bits used in feature address B0h to enable OTP access are shown in the table below.

OTP Access

To access OTP, perform the following command sequence:

- Issue the SET FEATURES register write (1Fh)
- Issue the OTP feature address (B0h)
- Issue the PAGE PROGRAM or PAGE READ command

It is important to note that after bits 6 and 7 of the OTP register are set by the user, the OTP area becomes read-only and no further programming is supported.

6 Memory organization

Figure 5. Memory organization

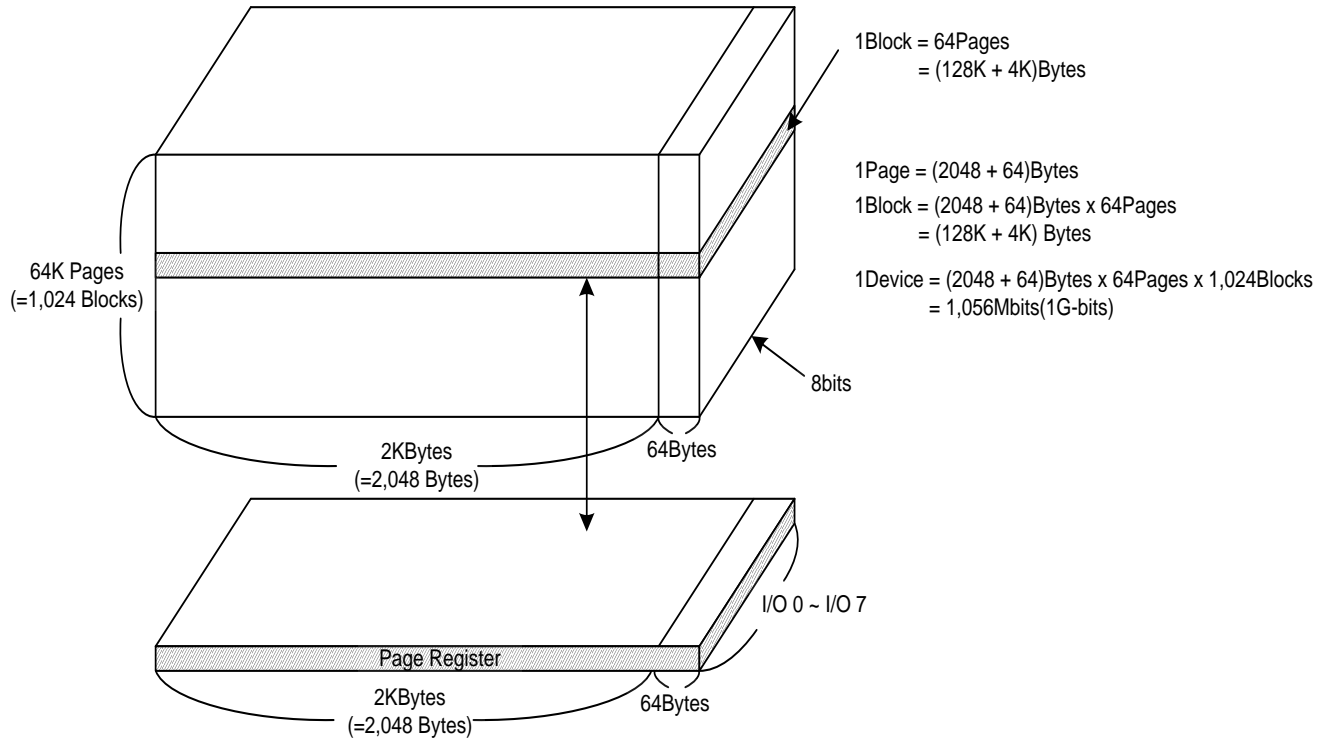

Page(2K Bytes) Configuration

| Area | Main Array(2,048 Bytes) | | | | Spare Array(64 Bytes) | | | |
|---------|-------------------------|------|------|------|-----------------------|------|------|------|
| | 1 | 2 | 3 | 4 | 1 | 2 | 3 | 4 |
| Column | 000h | 200h | 400h | 600h | 800h | 810h | 820h | 830h |
| Address | 1FFh | 3FFh | 5FFh | 7FFh | 80Fh | 81Fh | 82Fh | 83Fh |

Figure 6. Block diagram

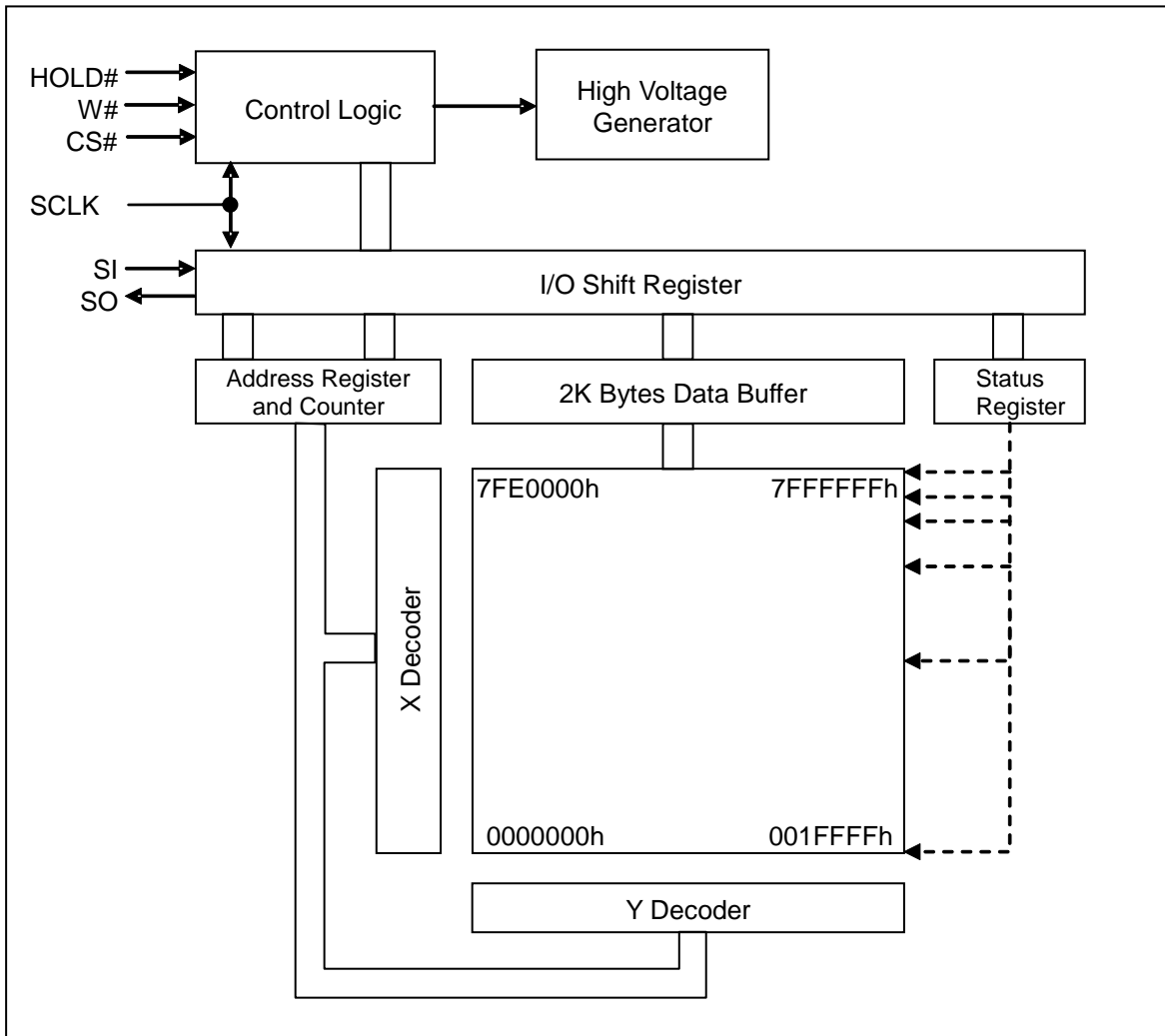

7 FUNCTIONAL DESCRIPTION

7.1 Standard SPI Instructions

The ATO25D1GA is accessed through an SPI compatible bus consisting of four signals: Serial Clock (CLK), Chip Select (CS#), Serial Data Input (SI) and Serial Data Output (SO). Standard SPI instructions use the SI input pin to serially write instructions, addresses or data to the device on the rising edge of CLK. The SO output pin is used to read data or status from the device on the falling edge of SCLK.

SPI bus operation Modes 0 (0, 0) and 3 (1, 1) are supported. The primary difference between Mode 0 and Mode 3 concerns the normal state of the SCLK signal when the SPI bus master is in standby and data is not being transferred to the Serial Flash. For Mode 0 the SCLK signal is normally low on the falling and rising edges of CS#. For Mode 3 the SCLK signal is normally high on the falling and rising edges of CS#.

7.2 Quad SPI Instructions

The ATO25D1GA supports Quad SPI operation when using the “Read from page buffer x4” command. This instruction allows data to be transferred to or from the device six to seven times the rate of ordinary Serial Flash. The Quad Read instruction offers a significant improvement in continuous and random access transfer rates allowing fast code-shadowing to RAM or execution directly from the SPI bus (XIP). When using Quad SPI instruction the SI and SO pins become bidirectional SIO0 and SIO1 and the WP# and HOLD# pins become SIO2 and SIO3 respectively. Quad SPI instructions require the Quad Enable bit (QE) in Status Register to be set.

7.3 Hold condition

The Hold (HOLD#) signal is used to pause any serial communications with the device without resetting the clocking sequence. However, taking this signal Low does not terminate any Write Status Register, Program or Erase cycle that is currently in progress.

To enter the Hold condition, the device must be selected, with Chip Select (CS#) Low.

The Hold condition starts on the falling edge of the Hold (HOLD#) signal, provided that this coincides with Serial Clock (SCLK) being Low (as shown in *Figure 7*).

The Hold condition ends on the rising edge of the Hold (HOLD#) signal, provided that this coincides with Serial Clock (SCLK) being Low.

If the falling edge does not coincide with Serial Clock (SCLK) being Low, the Hold condition starts after Serial Clock (SCLK) next goes Low. Similarly, if the rising edge does not coincide with Serial Clock (SCLK) being Low, the Hold condition ends after Serial Clock (SCLK) next goes Low. (This is shown in *Figure 7*).

During the Hold condition, the Serial Data Output (SO) is high impedance, and Serial Data Input (SI) and Serial Clock (SCLK) are Don't Care.

Normally, the device is kept selected, with Chip Select (CS#) driven Low, for the whole duration of the Hold condition. This is to ensure that the state of the internal logic remains unchanged from the moment of entering the Hold condition.

If Chip Select (CS#) goes High while the device is in the Hold condition, this has the effect of resetting the internal logic of the device. To restart communication with the device, it is necessary to drive Hold (HOLD#) High, and then to drive Chip Select (CS#) Low. This prevents the device from going back to the Hold condition.

Figure 7. Hold condition activation

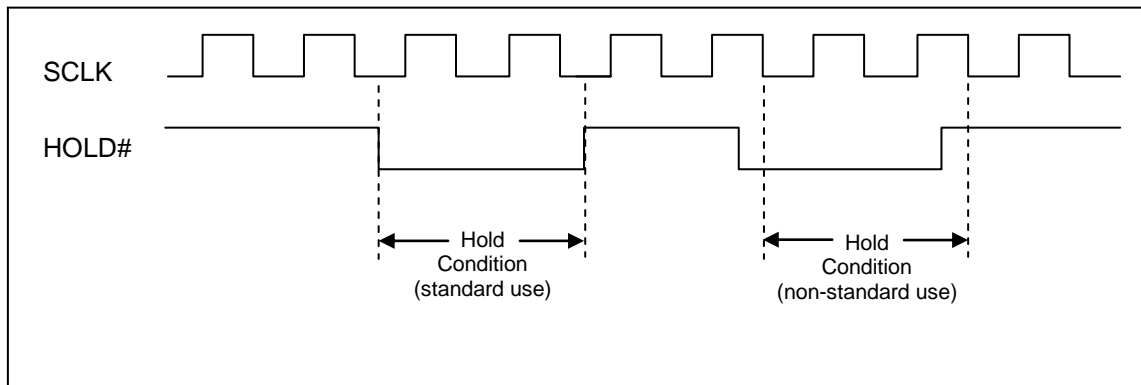

8 Instructions

All instructions, addresses and data are shifted in and out of the device, most significant bit first. Serial Data Input (SI) is sampled on the first rising edge of Serial Clock (SCLK) after Chip Select (CS#) is driven Low. Then, the one-byte instruction code must be shifted in to the device, most significant bit first, on Serial Data input (SI), each bit being latched on the rising edges of Serial Clock (SCLK).

The instruction set is listed in *Table 3*.

All attempts to access the memory array during a Write Status Register cycle, Program cycle or Erase cycle are ignored, and the internal Write Status Register cycle, Program cycle or Erase cycle continues unaffected.

Table 3. Instruction set

| Command | Op Code | Address Bytes | Dummy Bytes | Data Bytes | Note |
|-----------------------------|----------|---------------|-------------|------------|---|
| BLOCK ERASE | D8h | 3 | 0 | 0 | |
| GET FEATURE | 0Fh | 1 | 0 | 1 | Refer to Feature Register |
| SET FEATURE | 1Fh | 1 | 0 | 1 | |
| WRITE DISABLE | 04h | 0 | 0 | 0 | |
| WRITE ENABLE | 06h | 0 | 0 | 0 | |
| PROGRAM LOAD | 02h | 2 | 0 | 1 to 2112 | |
| PROGRAM LOAD x4 | 32h | 2 | 0 | 1 to 2112 | Command/Address is 1 bit, data is 4 bit |
| PROGRAM LOAD RANDOM DATA | 84h | 2 | 0 | 1 to 2112 | |
| PROGRAM LOAD RANDOM DATA x4 | 34h | 2 | 0 | 1 to 2112 | Command/Address is 1 bit, data is 4 bit |
| PROGRAM EXECUTE | 10h | 3 | 0 | 0 | |
| PAGE READ | 13h | 3 | 0 | 0 | |
| READ FROM PAGE BUFFER | 03h, 0Bh | 2 | 1 | 1 to 2112 | |
| READ FROM PAGE BUFFER x4 | 6Bh | 2 | 1 | 1 to 2112 | Command/Address is 1 bit, data is 4 bit |
| READ ID | 9Fh | 1 | 0 | 2 | Address is 00h to get JEDEC ID |
| RESET | FFh | 0 | 0 | 0 | |

8.1 Write Enable (WREN)

The Write Enable (WREN) instruction (*Figure 8*) sets the Write Enable Latch (WEL) bit.

The Write Enable Latch (WEL) bit must be set prior to every Page Program, Block Erase, and OTP program instruction.

The Write Enable (WREN) instruction is entered by driving Chip Select (CS#) Low, sending the instruction code, and then driving Chip Select (CS#) High.

Figure 8. Write Enable (WREN) instruction sequence

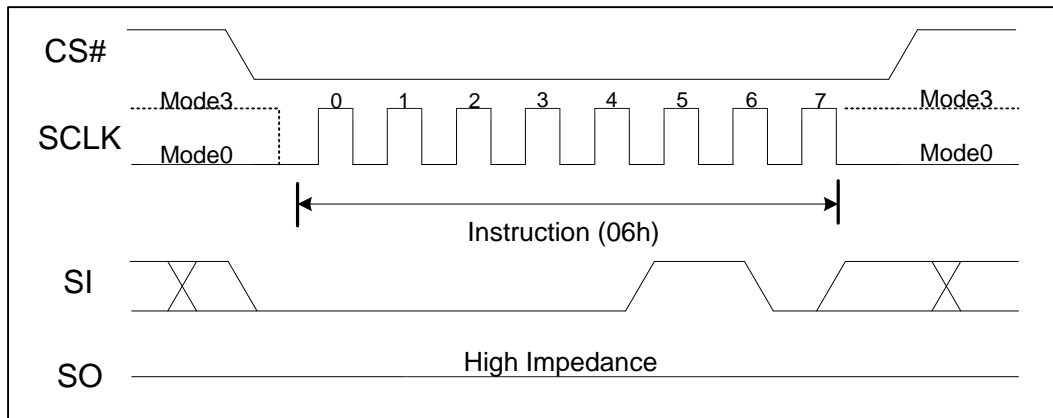

8.2 Write Disable (WRDI)

The Write Disable (WRDI) instruction (*Figure 9*) resets the Write Enable Latch (WEL) bit.

The Write Disable (WRDI) instruction is entered by driving Chip Select (CS#) Low, sending the instruction code, and then driving Chip Select (CS#) High. The Write Enable Latch (WEL) bit is reset under the following conditions:

- Power-up
- Write Disable (WRDI) instruction completion
- OTP program instruction completion
- Page Program (PP) instruction completion
- Block Erase (BE) instruction completion

Figure 9. Write Disable (WRDI) instruction sequence

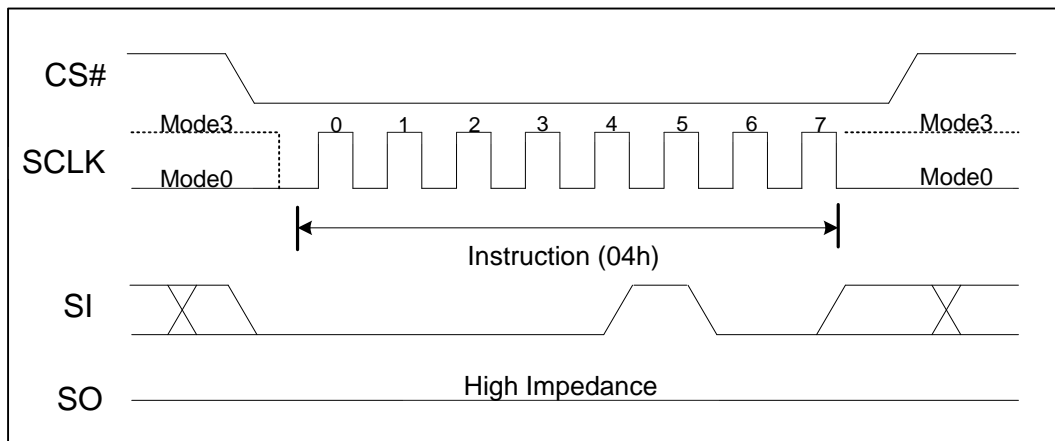

8.3 Read Identification (RDID)

The READ ID command is used to read the 2 bytes of identifier code programmed into the NAND Flash device. The READ ID command reads a 2-byte table (see below) that includes the Manufacturer ID and the device configuration.

- Manufacturer identification (one byte)
- Device identification (one byte)

Any Read Identification (RDID) instruction while an Erase or Program cycle is in progress is not decoded, and has no effect on the cycle that is in progress.

The instruction sequence is shown in *Figure 10*

The Read Identification (RDID) instruction is terminated by driving Chip Select (CS#) High at any time during data output.

When Chip Select (CS#) is driven High, the device is put in the Standby Power mode. Once in the Standby Power mode, the device waits to be selected, so that it can receive, decode and execute instructions.

Table 4. Read Identification (RDID) data-out sequence

| Instruction | Manufacturer Identification | Device Identification |
|-------------|-----------------------------|-----------------------|
| 9Fh | 9Bh | 12h |

Figure 10. Read Identification (RDID) instruction sequence and data-out sequence

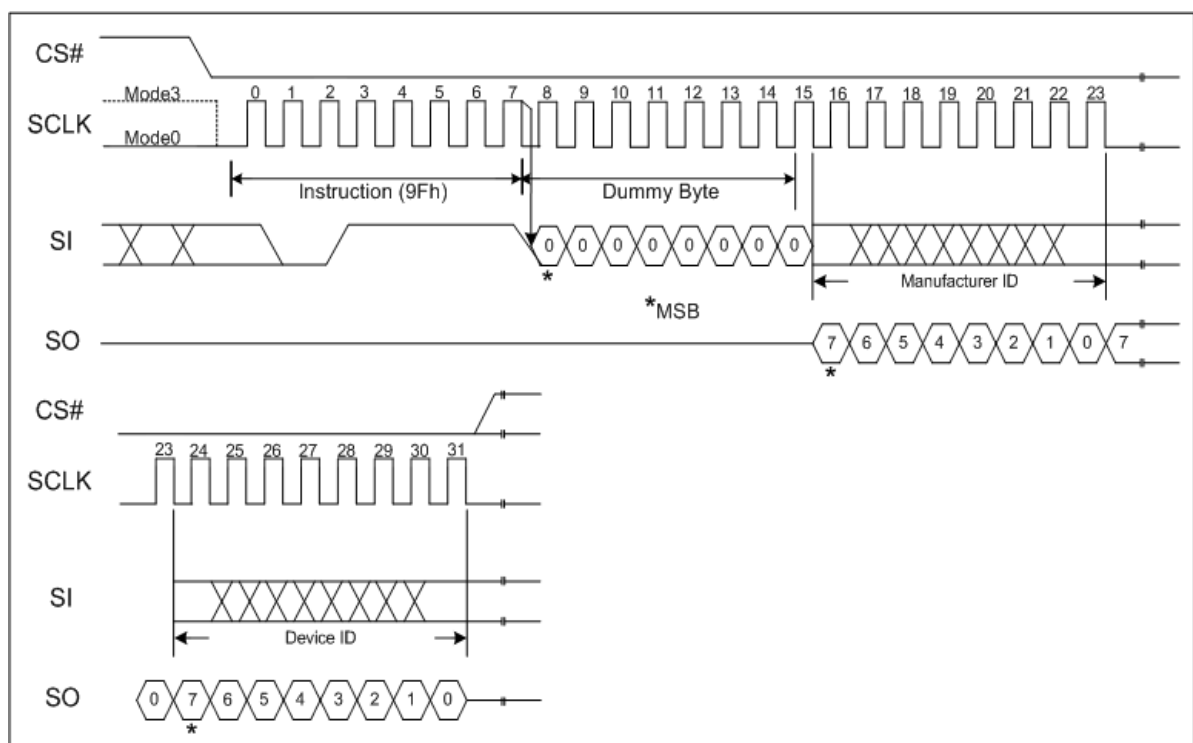

8.4 Software Reset

The Reset operation is used as a system (software) reset that puts the device in normal operating Ready mode.

To reset the ATO25D1GA the host drives CS# low, sends the Reset command(FFh),

A successful command execution will reset the device to SPI stand by read mode, which are their respective default states. A device reset during an active Program and Erase operation aborts the operation, which can cause the data of the targeted address range to be corrupted or lost.

Depending on the prior operation, the reset timing may vary. Recovery from a Write operation requires more latency time than recovery from other operations.

Figure 11. Reset sequence

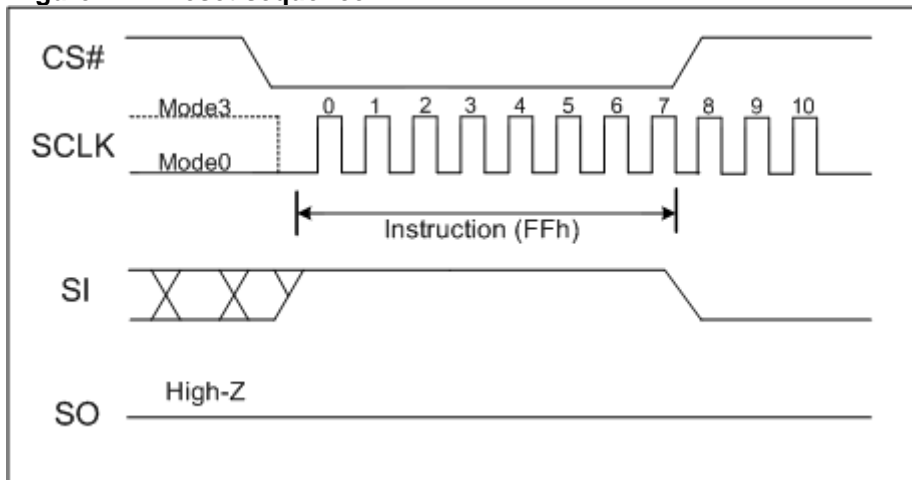

8.5 Feature Operation

The GET FEATURES (0Fh) and SET FEATURES (1Fh) commands are used to alter the device behavior from the default power-on behavior. These commands use a 1-byte feature address to determine which feature is to be read or modified. Features such as OTP and block locking can be enabled or disabled by setting specific bits in feature address A0h and B0h (shown in the following table). The status register is mostly read, except WEL, which is a writable bit with the WRITE ENABLE (06h) command.

Table 5. Status Registers

| Register | Address | Data Bits | | | | | | | |
|------------|---------|---------------------|------------|----------|----------|----------|----------|----------|----------|
| | | 7 | 6 | 5 | 4 | 3 | 2 | 1 | 0 |
| Block Lock | A0h | BRWD ⁽¹⁾ | Reserved | BP2 | BP1 | BP0 | Reserved | Reserved | Reserved |
| OTP | B0h | OTP Protect | OTP Enable | Reserved | Reserved | Reserved | Reserved | Reserved | QE |
| Status | C0h | Reserved | Reserved | Reserved | Reserved | P_Fail | E_Fail | WEL | OIP |

Note: 1. If BRWD is enabled and WP# is LOW, then the block lock register cannot be changed.

8.5.1 OIP bit

The Operation In Progress (OIP) bit indicates whether the memory is busy with a Write Status Register, Program or Erase cycle. When set to 1, such a cycle is in progress, when reset to 0 no such cycle is in progress.

8.5.2 WEL bit

The Write Enable Latch (WEL) bit indicates the status of the internal Write Enable Latch. When set to 1 the internal Write Enable Latch is set, when set to 0 the internal Write Enable Latch is reset and no Write Status Register, Program or Erase instruction is accepted.

8.5.3 BP2, BP1, BP0 bits

The Block Protect (BP2, BP1, BP0) bits define the size of the area to be software protected against Program and Erase instructions. These bits are written with the Set features instruction. When one or both of the Block Protect (BP2, BP1, BP0) bits is set to 1, the relevant memory area becomes protected against Page Program, OTP Program, Block Erase. The Block Protect (BP2, BP1, BP0) bits can be written provided that the Hardware Protected mode has not been set.

8.5.4 QE bit

The Quad Enable(QE) need to enable Quad operation. When the QE bit is set to a 0 state(factory default), W# pin and HOLD# are enabled. When the QE bit is set to a 1 the SIO1, SIO2 and SIO3 pins are enabled.

WARNING : The QE bit should never be set to a 1 during standard SPI operation if the W# or HOLD# pins are tied directly to the power supply or ground.

8.5.5 P_Fail bit

This bit indicates that a program failure has occurred (P_Fail set to 1). This bit will also be set if the user attempts to program an invalid address or a locked or protected region, including the OTP area. This bit is cleared during the PROGRAM EXECUTE command sequence or a RESET command (P_Fail = 0).

8.5.6 E_Fail bit

This bit indicates that an erase failure has occurred (E_Fail set to 1). This bit will also be set if the user attempts to erase a locked region, or if the ERASE operation fails. This bit is cleared (E_Fail = 0) at the start of the BLOCK ERASE command sequence or the RESET command.

Figure 12. Get Feature Timing

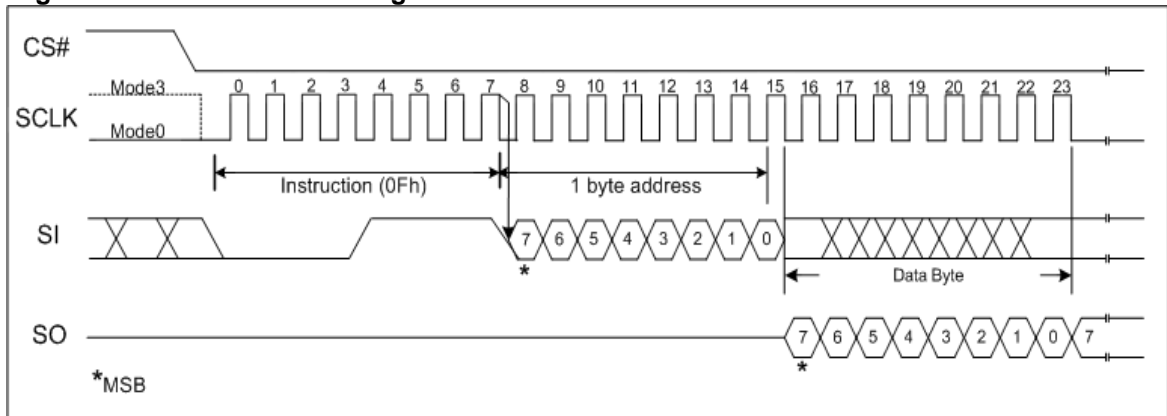
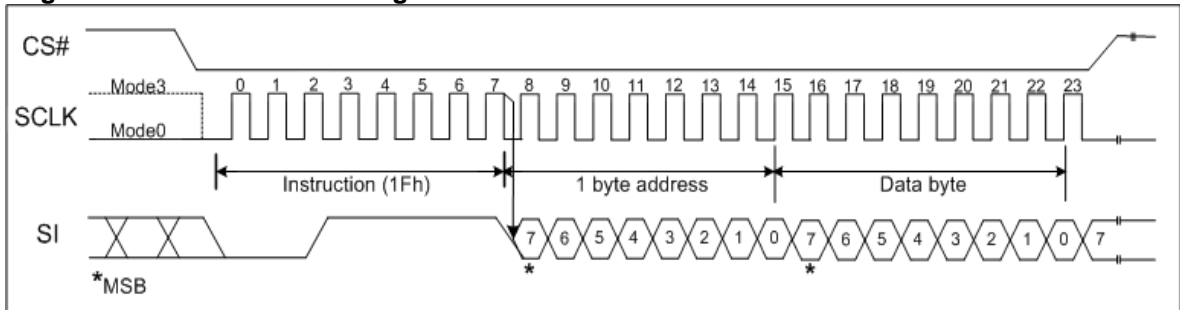

Figure 13. Set Feature Timing



8.6 Page Read(13h)

The PAGE READ (13h) command transfers the data from the NAND Flash array to the page buffer. The command sequence is follows:

- 13h (PAGE READ to page buffer)
- 0Fh (GET FEATURES command to read the status)
- 0Bh or 03h (Random data read)

The PAGE READ command requires a 24-bit address consisting of 8 dummy bits followed by a 16-bit block/page address. After the block/page addresses are registered, the device starts the transfer from the main array to the page buffer, and is busy for tRD time. During this time, the GET FEATURE (0Fh) command can be issued to monitor the status of the operation. Following a status of successful completion, the RANDOM DATA READ (03h or 0Bh) command must be issued in order to read the data out of the page buffer. The RANDOM DATA READ command requires a 16-bit column address for the starting byte address. The starting byte address can be 0 to 2111, but after the end of the page buffer is reached, the data does not wrap around and SO goes to a High-Z state. Refer to *Figure 14* and *Figure 15* to view the entire READ operation.

Figure 14. Page Read(13h) instruction Timing

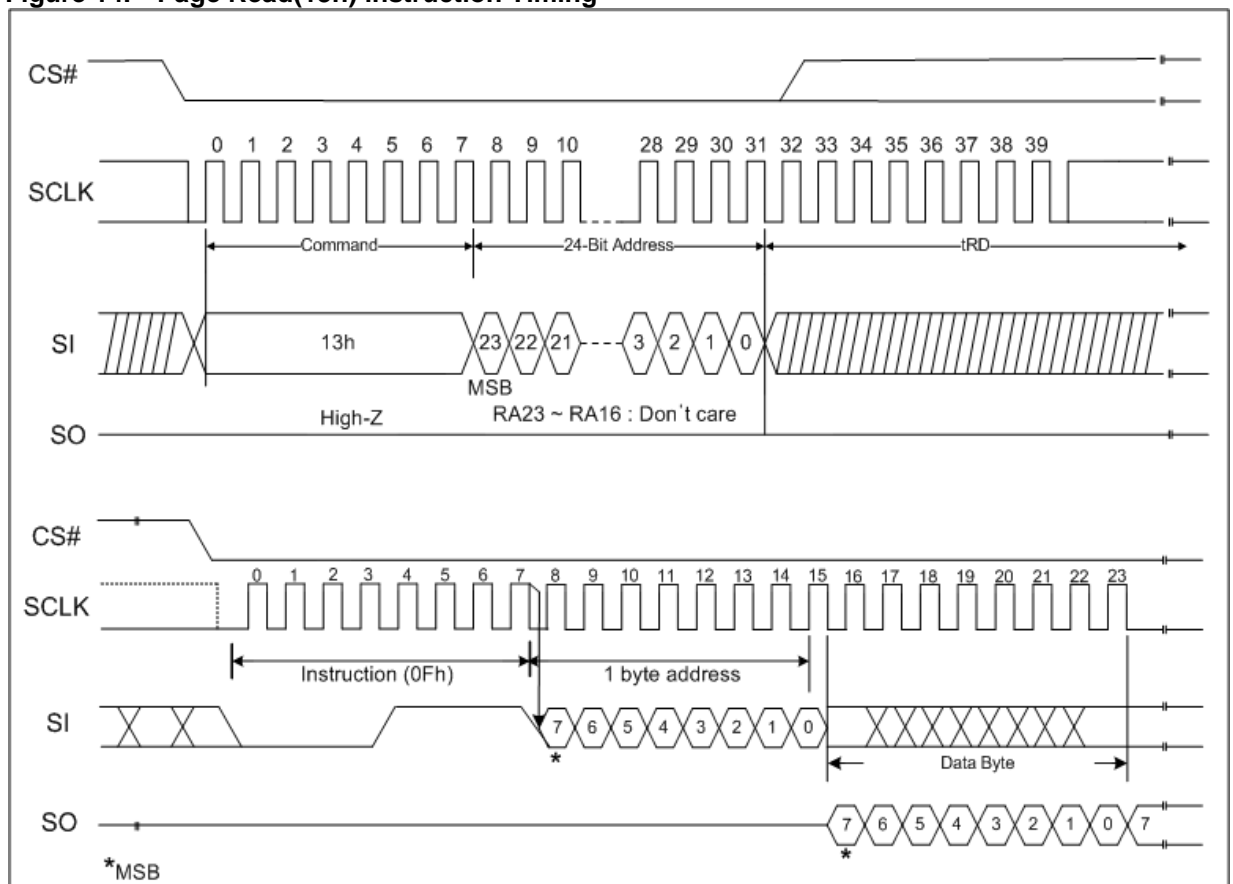

Figure 15. Read From Page Buffer(03h/0Bh) instruction Timing

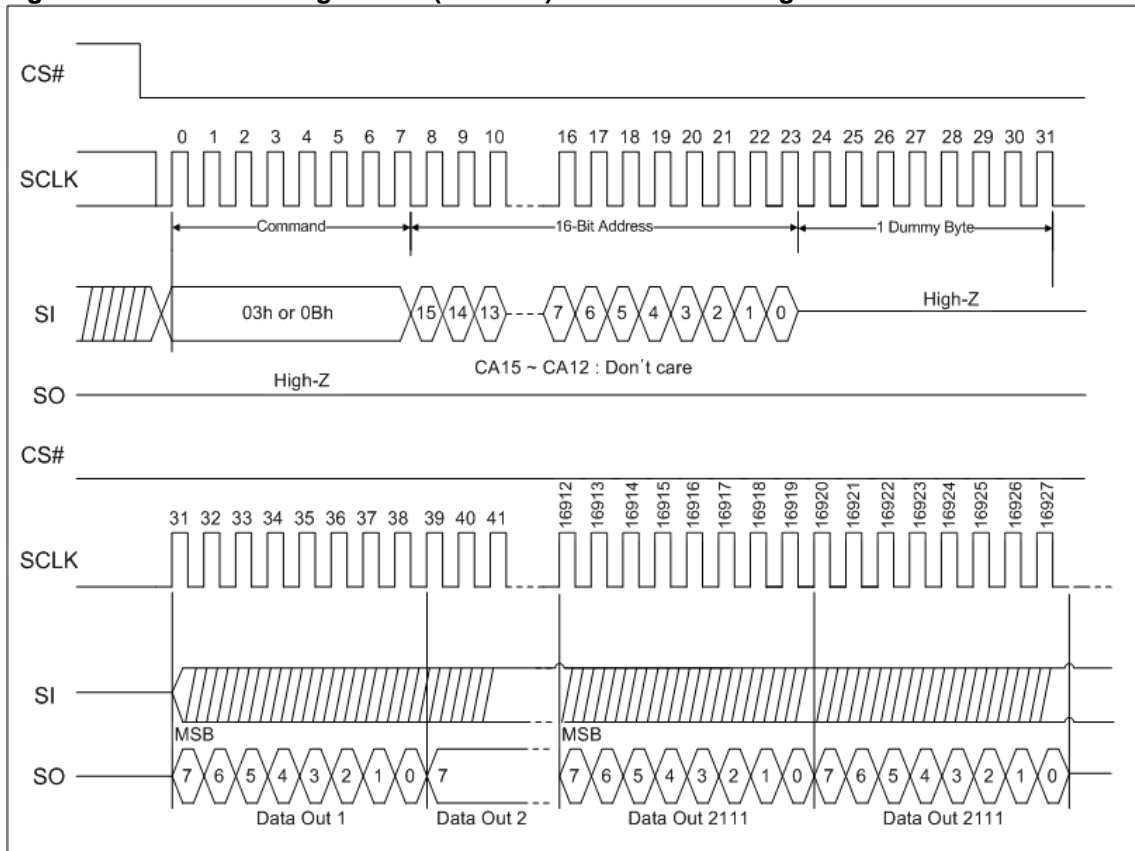
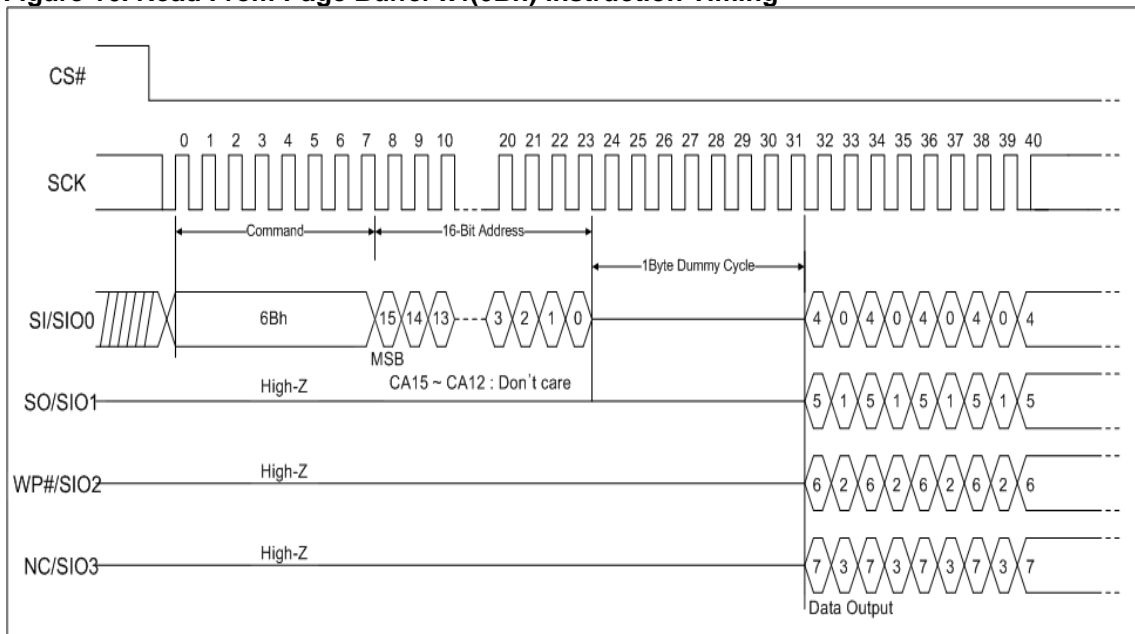

Figure 16. Read From Page Buffer x4(6Bh) instruction Timing



8.7 Page Program

The PAGE PROGRAM operation sequence programs 1 byte to 2112 bytes of data within a page. The page program sequence is as follows:

- 06h (WRITE ENABLE)
- 02h/32h (PROGRAM LOAD)
- 10h (PROGRAM EXECUTE)
- 0Fh (GET FEATURE command to read the status)

Prior to performing the PROGRAM LOAD operation, a WRITE ENABLE (06h) command must be issued. As with any command that changes the memory contents, the WRITE ENABLE must be executed in order to set the WEL bit. If this command is not issued, then the rest of the program sequence is ignored. WRITE ENABLE must be followed by a PROGRAM LOAD (02h/32h) command. PROGRAM LOAD consists of an 8-bit Op code, followed by a 16-bit column address, then the data bytes to be programmed. The data bytes are loaded into a page buffer that is 2112 bytes long. If more than 2112 bytes are loaded, then those additional bytes are ignored by the page buffer. The command sequence ends when CS goes from LOW to HIGH. *Figure 16* shows the PROGRAM LOAD operation.

After the data is loaded, a PROGRAM EXECUTE (10h) command must be issued to initiate the transfer of data from the page buffer to the main array. PROGRAM EXECUTE consists of an 8-bit Op code, followed by a 24-bit address. After the page/block address is registered, the memory device starts the transfer from the page buffer to the main array, and is busy for tPROG time. During this busy time, the status register can be polled to monitor the status of the operation (refer to the Status Register section). When the operation completes successfully, the next series of data can be loaded with the PROGRAM LOAD command. Only the Get Feature and Reset command are valid while programming is in progress. The number of consecutive partial page programming operation within the same page without an intervening erase operation must not exceed 4 for main array and 4 for spare array. And the device is limited to one partial page program per each area of main or spare array. (Refer to *Figure 5*)

Figure 17. Program Load(02h) instruction sequence

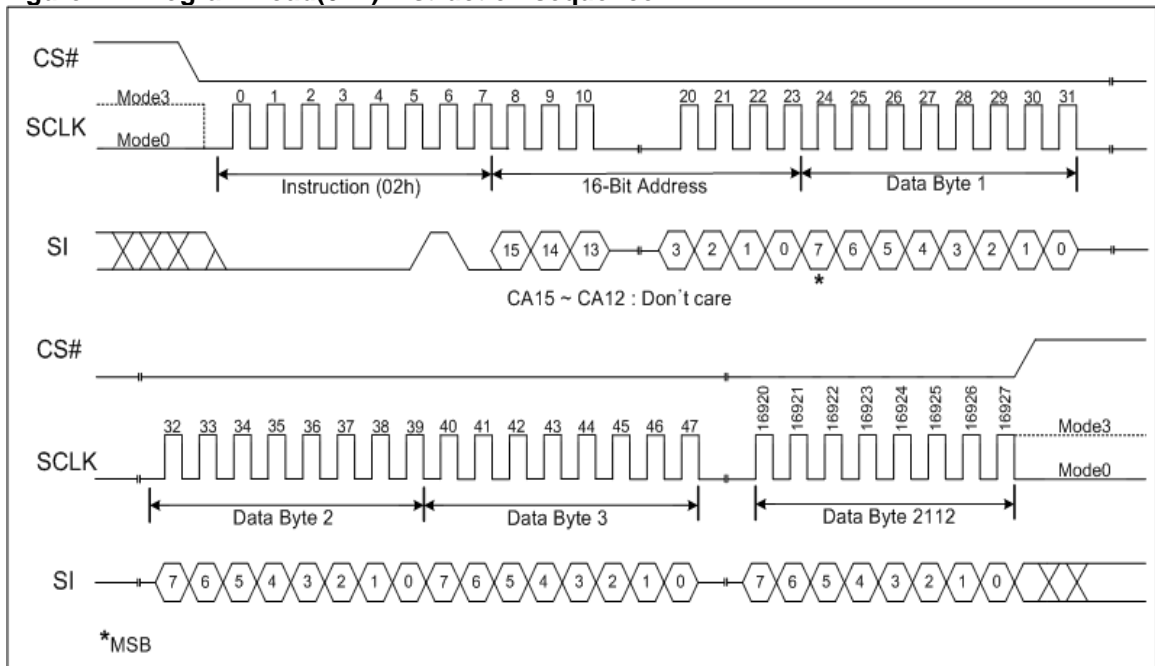

Figure 18. Program Load x4(32h) instruction sequence

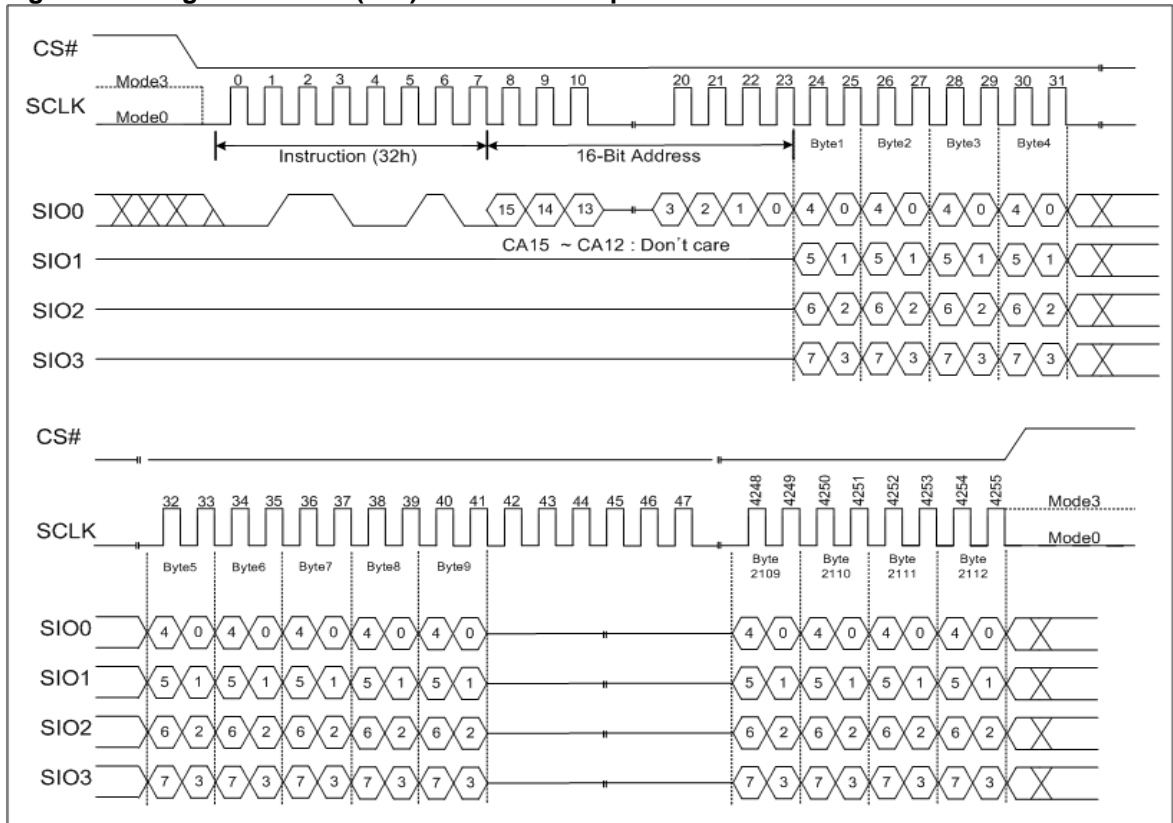
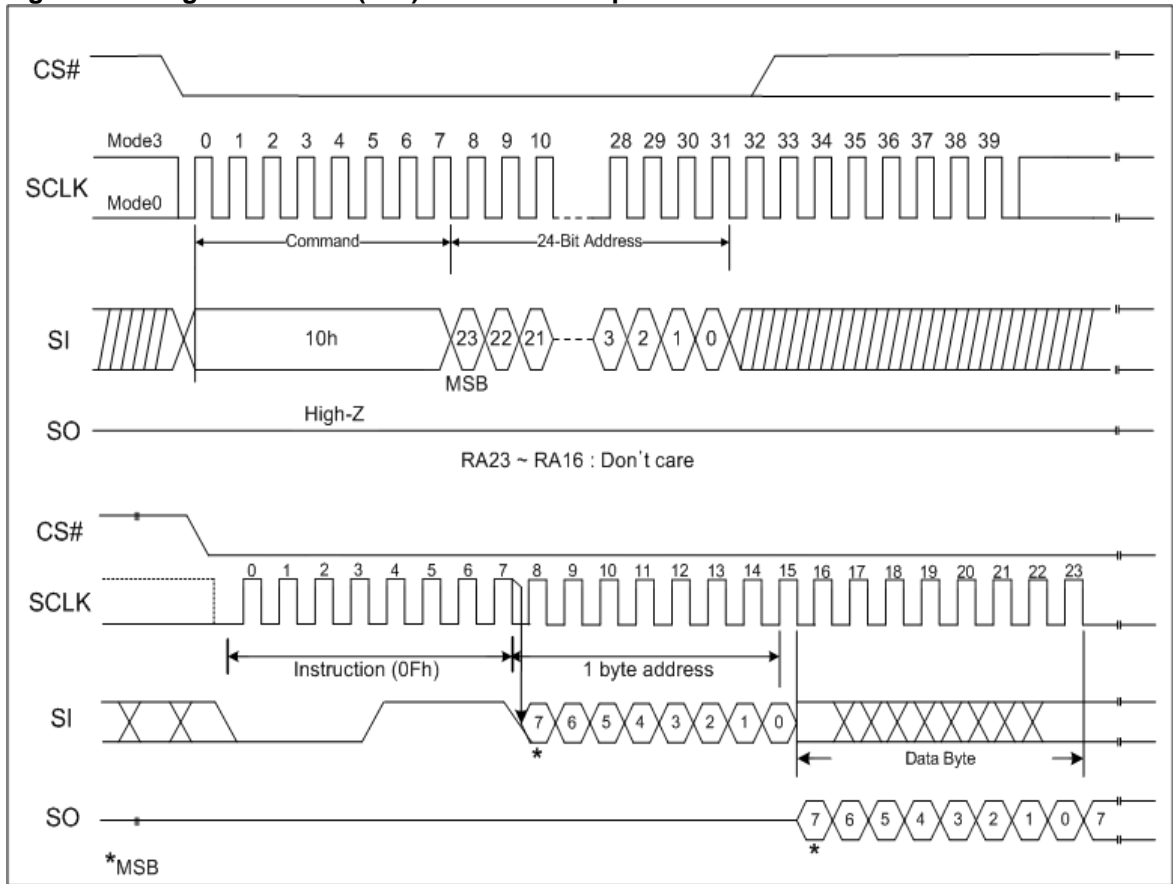

Figure 19. Program Execute(10h) instruction sequence



8.8 Random Data Program

The RANDOM DATA PROGRAM sequence programs or replaces data in a page with existing data. The random data program sequence is as follows:

- 06h (WRITE ENABLE)
- 84h/34h (PROGRAM LOAD RANDOM DATA)
- 10h (PROGRAM EXECUTE)
- 0Fh (GET FEATURE command to read the status)

Prior to performing a PROGRAM LOAD RANDOM DATA operation, a WRITE ENABLE(06h) command must be issued to change the contents of the memory array. Following a WRITE ENABLE (06) command, a PROGRAM LOAD RANDOM DATA (84h/34h) command must be issued. This command consists of an 8-bit Op code, a 16-bit column address. New data is loaded in the column address provided with the 12 bits. If the random data is not sequential, then another PROGRAM LOAD RANDOM DATA (84h/34h) command must be issued with a new column address. And the device is limited to one program data load per each a fixed length of 8 byte section within a 2112 byte(page).

After the data is loaded, a PROGRAM EXECUTE(10h) command can be issued to start the programming operation.

Figure 20. Program Load Random Data(84h) instruction sequence

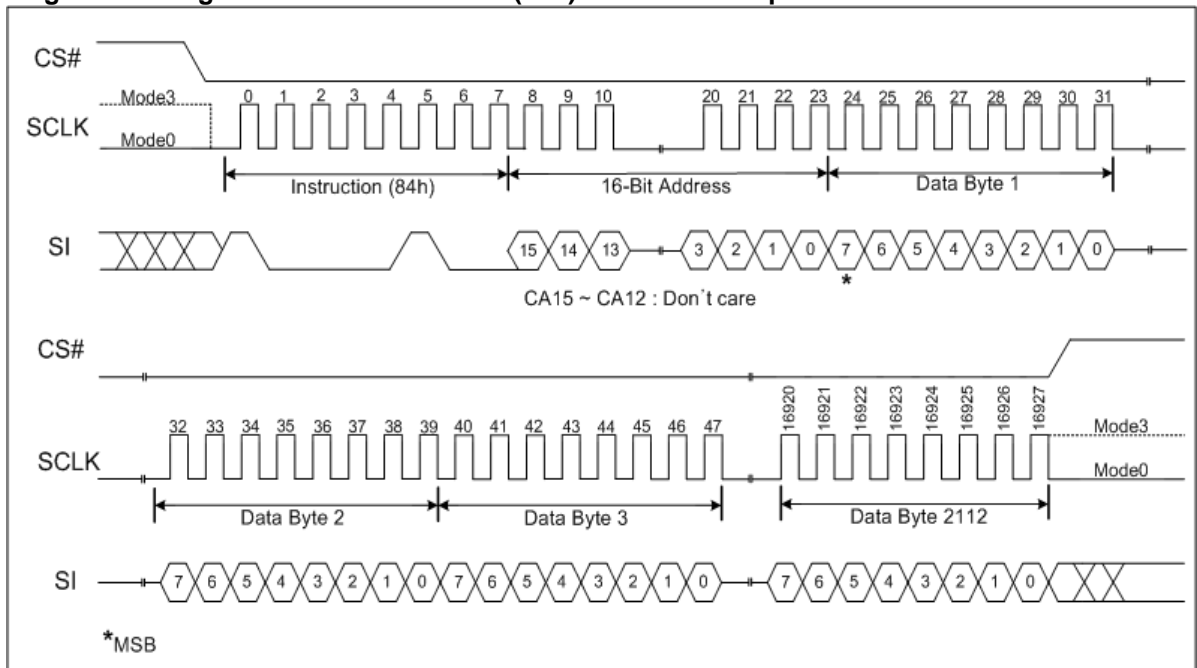
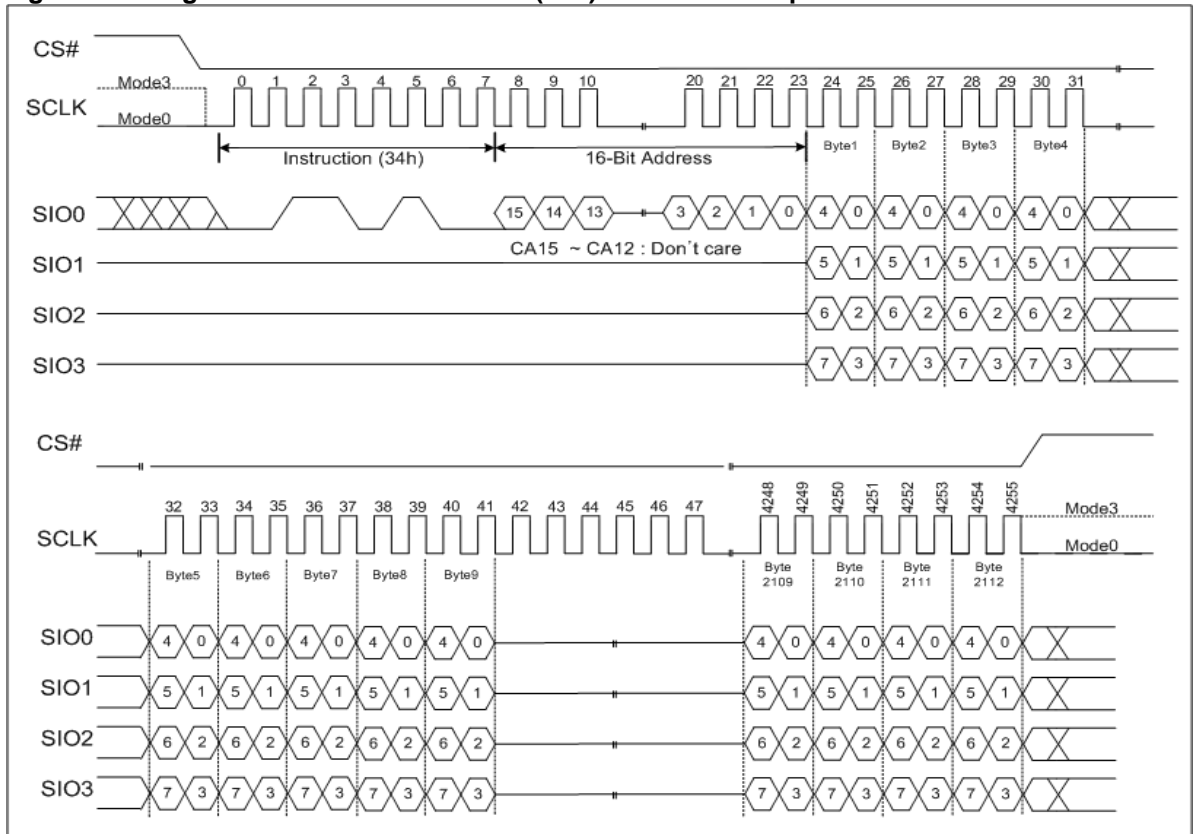

Figure 21. Program Load Random Data x4(34h) instruction sequence





8.9 Copy Back Program

The Copy Back Program command sequence programs or replaces data in a page with existing data. The Copy Back Program command sequence is as follows:

- **13h (PAGE READ to page buffer)**
- **06h (WRITE ENABLE)**
- **10h (PROGRAM EXECUTE)**
- **0Fh (GET FEATURE command to read the status)**

Prior to performing an internal data move operation, the target page content must be read into the page buffer. This is done by issuing a PAGE READ (13h) command. The PAGE READ command must be followed with a WRITE ENABLE (06h) command in order to change the contents of memory array. After the WRITE ENABLE command is issued, a PROGRAM EXECUTE (10h) command can be issued to start the programming operation.

8.10 Block Erase (D8h)

The BLOCK ERASE (D8h) command is used to erase at the block level. The blocks are organized as 64 pages per block, 2112 bytes per page (2048 + 64 bytes). Each block is 132 Kbytes. The BLOCK ERASE command (D8h) operates on one block at a time. The command sequence for the BLOCK ERASE operation is as follows:

- 06h (WRITE ENBALE command)
- D8h (BLOCK ERASE command)
- 0Fh (GET FEATURES command to read the status register)

Prior to performing the BLOCK ERASE operation, a WRITE ENABLE (06h) command must be issued. As with any command that changes the memory contents, the WRITE ENABLE command must be executed in order to set the WEL bit. If the WRITE ENABLE command is not issued, then the rest of the erase sequence is ignored. A WRITE ENABLE command must be followed by a BLOCK ERASE (D8h) command. This command requires a 24-bit address consisting of 8 dummy bits followed by an 16-bit row address. After the row address is registered, the control logic automatically controls timing and erase-verify operations. The device is busy for tERS time during the BLOCK ERASE operation. The GET FEATURES (0Fh) command can be used to monitor the status of the operation. Only the Get Feature and Reset command are valid while erasing is in progress.

Figure 22. Block Erase instruction sequence

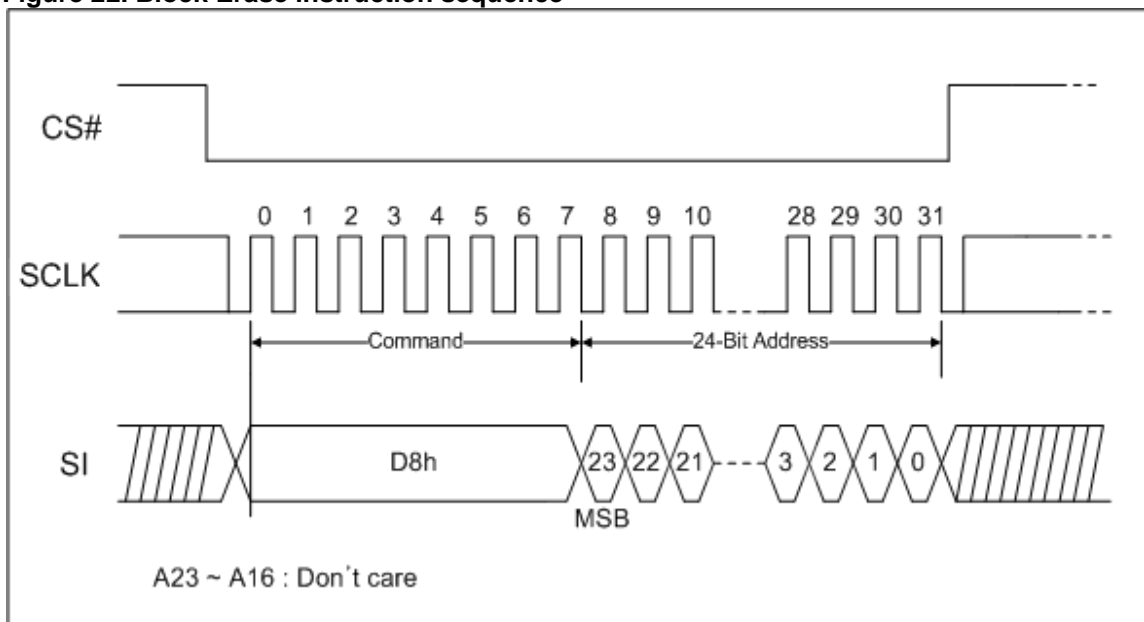

9 Error Management

This NAND Flash device is specified to have the minimum number of valid blocks (NVB) of the total available blocks per die shown in the table below. This means the devices may have blocks that are invalid when shipped from the factory. An invalid block is one that contains at least one page that has more bad bits than can be corrected by the minimum required ECC. Additional bad blocks may develop with use. However, the total number of available blocks will not fall below NVB during the endurance life of the product.

Although NAND Flash memory devices may contain bad blocks, they can be used reliably in systems that provide bad-block management and error-correction algorithms. This ensures data integrity. Internal circuitry isolates each block from other blocks, so the presence of a bad block does not affect the operation of the rest of the NAND Flash array.

NAND Flash devices are shipped from the factory erased. The factory identifies invalid blocks before shipping by attempting to program the bad-block mark into every location in the first page of each invalid block. It may not be possible to program every location in an invalid block with the bad-block mark. However, the first spare area location in each bad block is guaranteed to contain the bad-block mark. See the following table for the bad-block mark.

System software should initially check the first spare area location for non-FFh data on the first page of each block prior to performing any program or erase operations on the NAND Flash device. A bad-block table can then be created, enabling system software to map around these areas. Factory testing is performed under worst-case conditions. Because invalid blocks may be marginal, it may not be possible to recover the bad-block marking if the block is erased. The 1st block, which is placed on 00h block address, is guaranteed to be a valid block up to 1K program/erase cycles.

Table 6. Error Management Details

| Description | Requirement |
|--------------------------------------|-------------|
| Minimum number of valid blocks (Nvb) | 1004 |
| Total available blocks per die | 1024 |
| First spare area location | Byte 2048 |
| Bad block mark | 00h |

10 Power-up and Power-down

At Power-up and Power-down, the device must not be selected (that is Chip Select (S) must follow the voltage applied on V_{CC}) until V_{CC} reaches the correct value:

- $V_{CC}(\text{min})$ at Power-up, and then for a further delay of t_{VSL}
- V_{SS} at Power-down

To avoid data corruption and inadvertent write operations during Power-up, a Power On Reset (POR) circuit is included. The logic inside the device is held reset while V_{CC} is less than the POR threshold value, V_{WI} – all operations are disabled, and the device does not respond to any instruction.

Moreover, the device ignores all Write Enable (WREN), Page Program, Block Erase (BE), OTP Program instructions until a time delay of t_{PUW} has elapsed after the moment that V_{CC} rises above the V_{WI} threshold. However, the correct operation of the device is not guaranteed if, by this time, V_{CC} is still below $V_{CC}(\text{min})$. No Write Status Register, Program or Erase instructions should be sent until the later of:

- t_{PUW} after V_{CC} passed the V_{WI} threshold
- t_{VSL} after V_{CC} passed the $V_{CC}(\text{min})$ level

These values are specified in *Table 8*.

If the delay, t_{VSL} , has elapsed, after V_{CC} has risen above $V_{CC}(\text{min})$, the device can be selected for READ instructions even if the t_{PUW} delay is not yet fully elapsed. At Power-up, the device is in the following state:

- The device is in the Standby mode (not the Deep Power-down mode).
- The Write Enable Latch (WEL) bit is reset.
- The Operation In Progress (OIP) bit is reset.

Normal precautions must be taken for supply rail decoupling, to stabilize the V_{CC} feed. Each device in a system should have the V_{CC} rail decoupled by a suitable capacitor close to the package pins. (Generally, this capacitor is of the order of 100 nF).

At Power-down, when V_{CC} drops from the operating voltage, to below the Power On Reset (POR) threshold value, V_{WI} , all operations are disabled and the device does not respond to any instruction. (The designer needs to be aware that if a Power-down occurs while a Write, Program or Erase cycle is in progress, some data corruption can result.)

Figure 23. Power-up timing

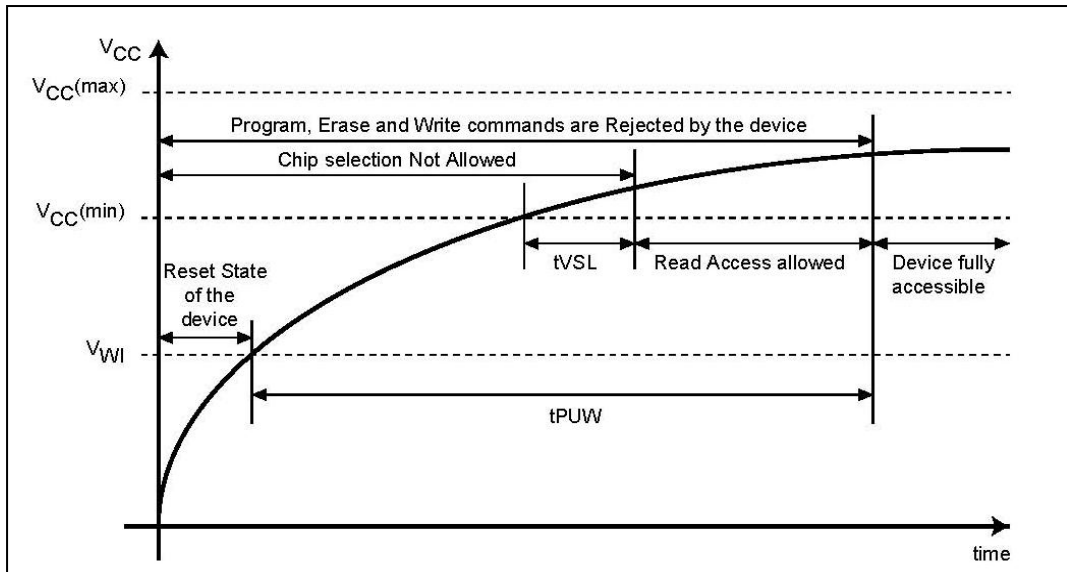

Table 7. Power-up timing and V_{WI} threshold

| Symbol | Parameter | Min. | Max. | Unit |
|-----------------|---------------------------------|------|------|---------|
| $t_{VSL}^{(1)}$ | $V_{CC(min)}$ to S low | 10 | | μs |
| $t_{PUW}^{(1)}$ | Time delay to Write instruction | 1 | 10 | ms |
| $V_{WI}^{(1)}$ | Write Inhibit voltage | 1 | 2 | V |

1. These parameters are characterized only.

11 Initial delivery state

The device is delivered with the memory array erased: all bits are set to 1 (each byte contains FFh). The Status Register contains 00h (all Status Register bits are 0).

12 Maximum rating

Stressing the device above the rating listed in the absolute maximum ratings table may cause permanent damage to the device. These are stress ratings only and operation of the device at these or any other conditions above those indicated in the operating sections of this specification is not implied. Exposure to absolute maximum rating conditions for extended periods may affect device reliability. Refer also to relevant quality documents.

Table 8. Absolute maximum ratings

| Symbol | Parameter | Min. | Max. | Unit |
|-------------------|---|-------|-----------------------|------|
| T _{STG} | Storage temperature | -65 | 150 | °C |
| T _{LEAD} | Lead temperature during soldering | | see (0) | °C |
| V _{IO} | Input and output voltage (with respect to ground) | -0.6 | V _{CC} + 0.4 | V |
| V _{CC} | Supply voltage | -0.6 | 4.6 | V |
| V _{ESD} | Electrostatic discharge voltage (Human Body model) (1) | -2000 | 2000 | V |

0. Compliant with JEDEC Std J-STD-020C (for small body, Sn-Pb or Pb assembly)

1. JEDEC Std JESD22-A114A (C1=100 pF, R1=1500 Ω, R2=500 Ω)

13 DC and AC parameters

This section summarizes the operating and measurement conditions, and the DC and AC characteristics of the device. The parameters in the DC and AC Characteristic tables that follow are derived from tests performed under the Measurement Conditions summarized in the relevant tables. Designers should check that the operating conditions in their circuit match the measurement conditions when relying on the quoted parameters.

Table 9. Operating conditions

| Symbol | Parameter | | Min. | Max. | Unit |
|--------|-------------------------------|----------------|------|------|------|
| VCC | Supply voltage | | 2.7 | 3.6 | V |
| TA | Ambient operating temperature | E(Extended) | -30 | 85 | °C |
| | | C(Commercial) | 0 | 70 | °C |
| | | I (Industrial) | -40 | 85 | °C |

Table 10. Data retention and endurance

| Parameter | Condition | Min. | Max. | Unit |
|----------------------|-----------|------|---------|-------------------|
| Erase/Program cycles | | | 100,000 | cycles per sector |
| Data Retention | | | 10 | years |

Table 11. AC measurement conditions

| Symbol | Parameter | Min. | Max. | Unit |
|--------|----------------------------------|------------------|------|------|
| CL | Load capacitance | 30(15pF/133MHz) | | pF |
| | Input rise and fall times | | 5 | ns |
| | Input pulse voltages | 0.2VCC to 0.8VCC | | V |
| | Input timing reference voltages | 0.3VCC to 0.7VCC | | V |
| | Output timing reference voltages | VCC / 2 | | V |

1. Output Hi-Z is defined as the point where data out is no longer driven.

Figure 24. AC measurement I/O waveform

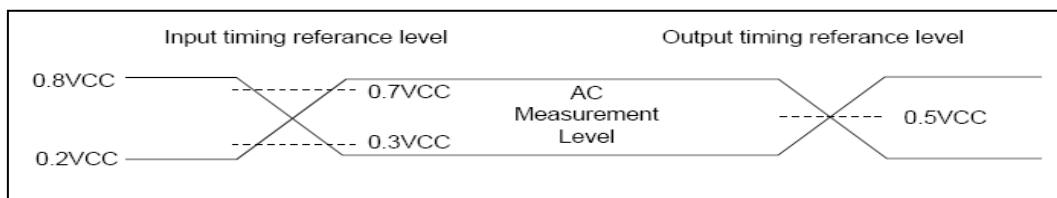

Table 12. Capacitance⁽¹⁾

| Symbol | Parameter | Test condition | Min. | Max. | Unit |
|--------|--------------------------------|----------------|------|------|------|
| COUT | Output capacitance (Q) | VOUT = 0 V | | 8 | pF |
| CIN | Input capacitance (other pins) | VIN = 0 V | | 6 | pF |

1. Sampled only, not 100% tested, at TA = 25 °C and a frequency of 20 MHz.

Table 13. DC characteristics

| Symbol | Parameter | Test condition (in addition to those in Table9) | Min. | Max. | Unit |
|------------------|---------------------------------|--|-----------------------|-----------------------|------|
| I _{LI} | Input leakage current | | | ± 2 | μA |
| I _{LO} | Output leakage current | | | ± 2 | μA |
| I _{CC1} | Standby current | CS# = V _{CC} , V _{IN} = V _{SS} or V _{CC} | 1 | 50 | μA |
| I _{CC2} | Deep Power-down current | CS# = V _{CC} , V _{IN} = V _{SS} or V _{CC} | 1 | 15 | μA |
| I _{CC3} | Operating current (READ) | SCLK = 0.1V _{CC} / 0.9.V _{CC} at 104 MHz, Q = open | 10 | 20 | mA |
| | | SCLK = 0.1V _{CC} / 0.9.V _{CC} at 33 MHz, Q = open | 8 | 12 | mA |
| I _{CC4} | Operating current (Program) | CS# = V _{CC} | 10 | 20 | mA |
| I _{CC5} | Operating current (Block Erase) | CS# = V _{CC} | 10 | 20 | mA |
| V _{IL} | Input low voltage | | -0.5 | 0.2xV _{CC} | V |
| V _{IH} | Input high voltage | | 0.8xV _{CC} | V _{CC} + 0.4 | V |
| V _{OL} | Output low voltage | I _{OL} = 1.6mA | | 0.2 | V |
| V _{OH} | Output high voltage | I _{OH} = -100 μA | V _{CC} - 0.2 | | V |

Table 14. AC characteristics (104 MHz operation)

| Test conditions specified in Table9 and Table11 | | | | | | |
|---|------------------|---|--------------------|---------------------|------|------|
| Symbol | Alt. | Parameter | Min. | Typ. ⁽¹⁾ | Max. | Unit |
| f _Q | f _Q | Clock frequency for the following instructions: Read, Page Program, Block Erase, WREN, WRDI, RDID, Get Feature, Set Feature | D.C. | | 104 | MHz |
| t _{RD} | t _R | Page Read time (cell array to page buffer) | | | 25 | us |
| t _{CH} ⁽²⁾ | t _{CLH} | Clock High time | 4.5 | | | ns |
| t _{CL} ⁽²⁾ | t _{CLL} | Clock Low time | 4.5 | | | ns |
| t _{CLCH} ⁽³⁾ | | Clock Rise time ⁽⁴⁾ (peak to peak) | 0.1 | | | V/ns |
| t _{CHCL} ⁽³⁾ | | Clock Fall time ⁽³⁾ (peak to peak) | 0.1 | | | V/ns |
| t _{SLCH} | t _{CSS} | CS# active setup time (relative to C) | 5 | | | ns |
| t _{CHSL} | | CS# not active hold time (relative to C) | 7 | | | ns |
| t _{DVCH} | t _{DSU} | Data In setup time | 3 | | | ns |
| t _{CHDX} | t _{DH} | Data In hold time | 5 | | | ns |
| t _{CHSH} | | CS# active hold time (relative to C) | 5 | | | ns |
| t _{SHCH} | | CS# not active setup time (relative to C) | 5 | | | ns |
| t _{SHSL} | t _{CSH} | CS# deselect time | 30 | | | ns |
| t _{SHQZ} ⁽³⁾ | t _{DIS} | Output disable time | | | 8 | ns |
| t _{CLQV} | t _V | Clock Low to Output Valid(30pF) | | | 8 | ns |
| t _{CLQV2} | t _{V2} | Clock Low to Output Valid(15pF) | | | 6 | ns |
| t _{CLQX} | t _{HO} | Output hold time | 0 | | | ns |
| t _{HLCH} | | HOLD setup time (relative to C) | 5 | | | ns |
| t _{CHHH} | | HOLD hold time (relative to C) | 5 | | | ns |
| t _{HHCH} | | HOLD setup time (relative to C) | 5 | | | ns |
| t _{CHHL} | | HOLD hold time (relative to C) | 5 | | | ns |
| t _{HHQX} ⁽³⁾ | t _{LZ} | HOLD to Output Low-Z | | | 8 | ns |
| t _{HLQZ} ⁽³⁾ | t _{HZ} | HOLD to Output High-Z | | | 8 | ns |
| t _{WHSL} ⁽⁵⁾ | | Write Protect setup time | 20 | | | ns |
| t _{SHWL} ⁽⁵⁾ | | Write Protect hold time | 100 | | | ns |
| t _{DP} ⁽³⁾ | | CS# High to Deep Power-down mode | | | 10 | μs |
| t _{PP} | | Page Program time | | 200 | 500 | us |
| t _{BE} | | Block Erase time | | 2 | 3 | ms |
| t _{RST} | | After Reset, Recovery time for RD/PGM/Erase | Max 5us/10us/500us | | | μs |
| NOP | | Number of partial programming operation supported. | Main | | 4 | |
| | | | Spare | | 4 | |

1 Typical values given for TA = 25°C.

2 t_{CH} + t_{CL} must be greater than or equal to 1/ f_C

3 Value guaranteed by characterization, not 100% tested in production.

4 Expressed as a slew-rate.

Figure 25. Serial input timing

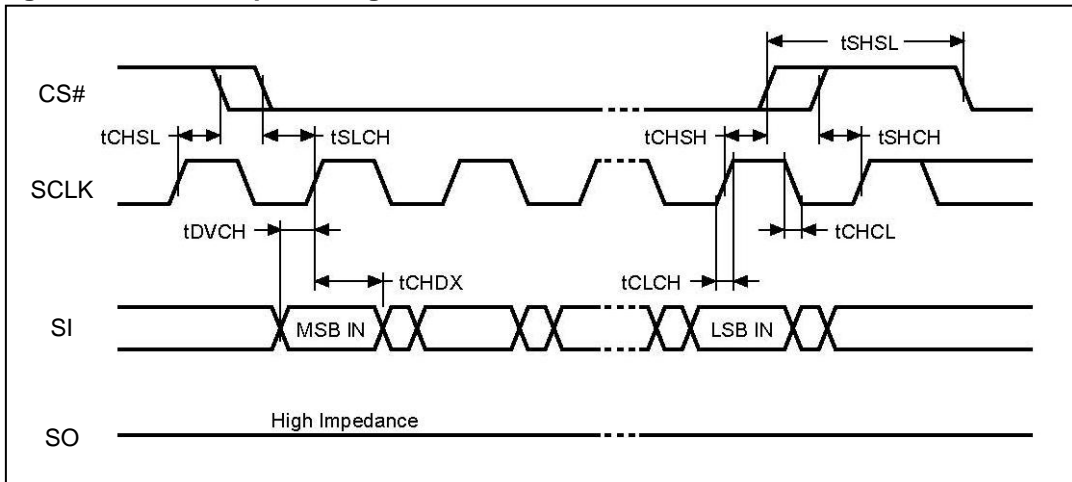

Figure 26. Write protect setup and hold timing

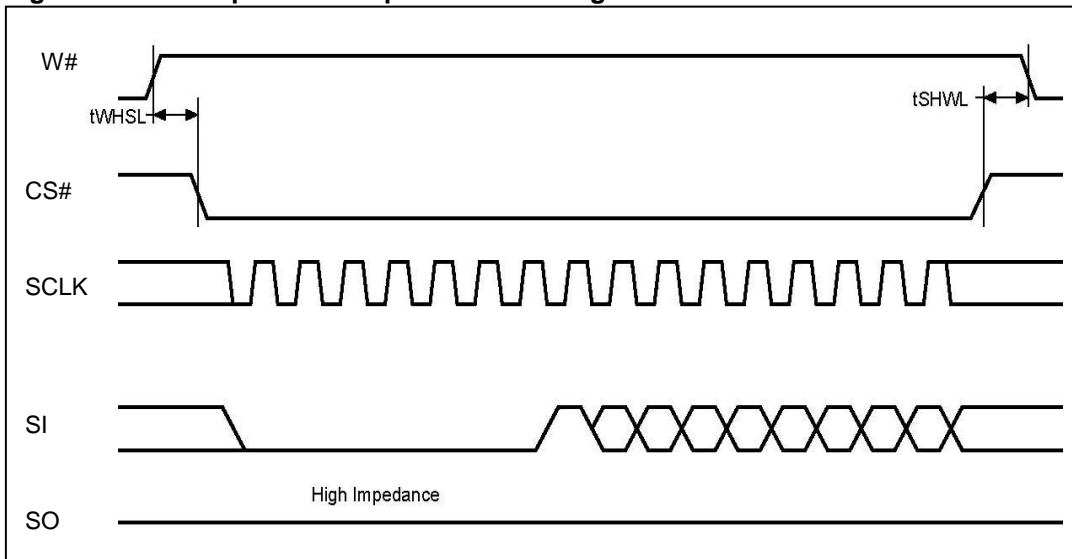

Figure 27. Hold timing

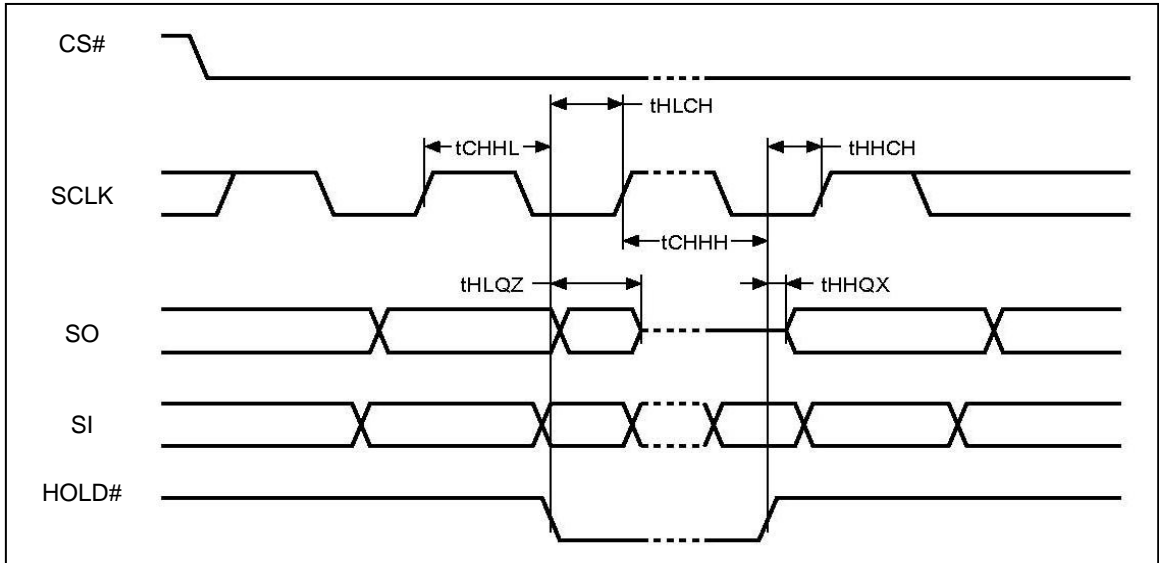
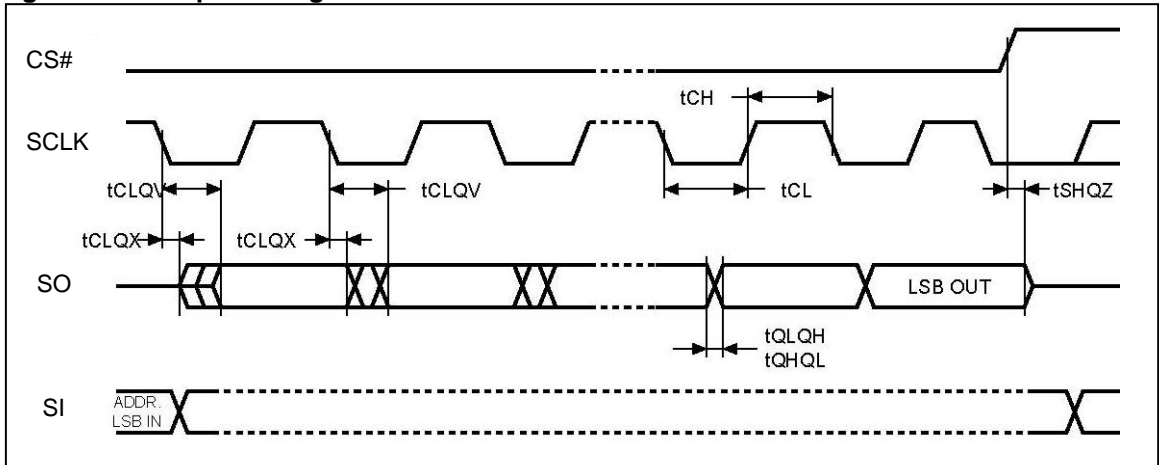
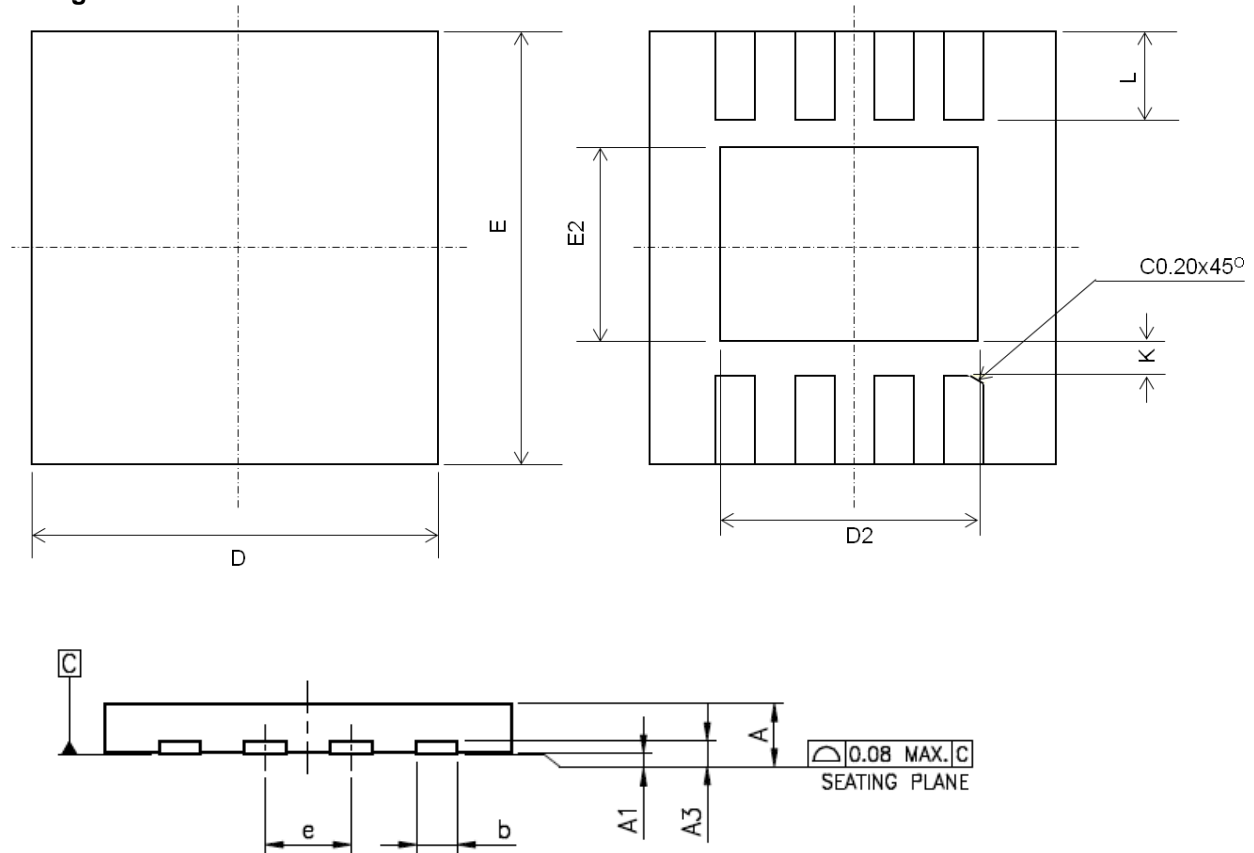

Figure 28. Output timing



14 Package mechanical

Figure 29. 8-Contact 8x6mm WSON



| SYMBOL | MILLIMETERS | | |
|--------|-------------|------|------|
| | MIN. | NOM. | MAX. |
| A | 0.70 | 0.75 | 0.80 |
| A1 | 0.00 | 0.02 | 0.05 |
| A3 | 0.20 REF. | | |
| b | 0.55 | 0.60 | 0.65 |
| D | 5.90 | 6.00 | 6.10 |
| E | 7.90 | 8.00 | 8.10 |
| e | 1.27 BSC | | |
| L | 1.90 | 1.95 | 2.00 |
| K | 0.20 | - | - |

| PAD SIZE | E2 | | | D2 | | |
|----------|------|------|------|------|------|------|
| | MIN. | NOM. | MAX. | MIN. | NOM. | MAX. |
| | 3.35 | 3.40 | 3.45 | 4.25 | 4.30 | 4.35 |

Figure 30. 16-Pin SOIC 300-mil

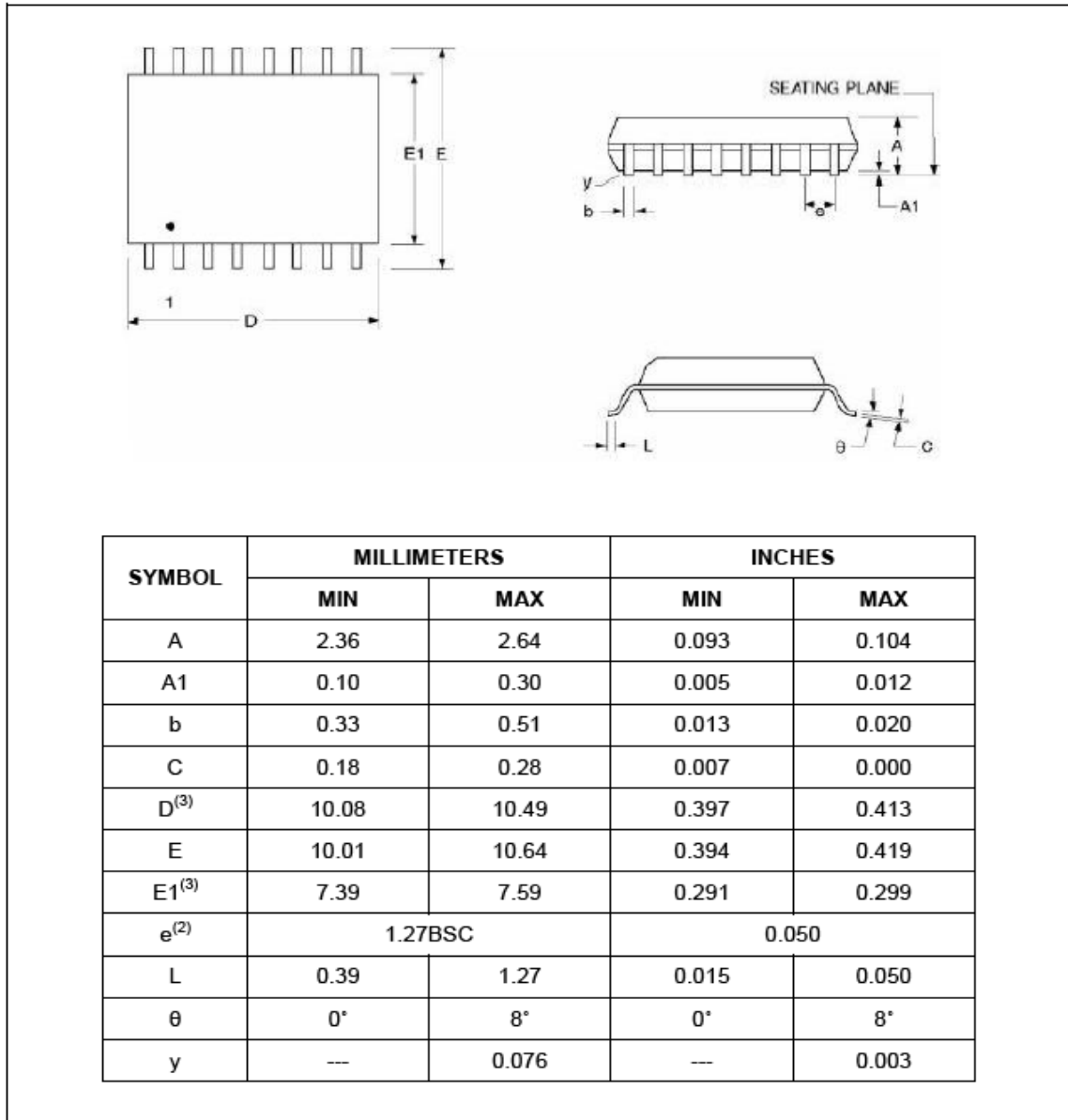

Notes:

1. Controlling dimensions: inches, unless otherwise specified.
2. BSC = Basic lead spacing between centers.
3. Dimensions D and E1 do not include mold flash protrusions and should be measured from the bottom of the package.

15 Part Numbering

Table 15. Ordering information

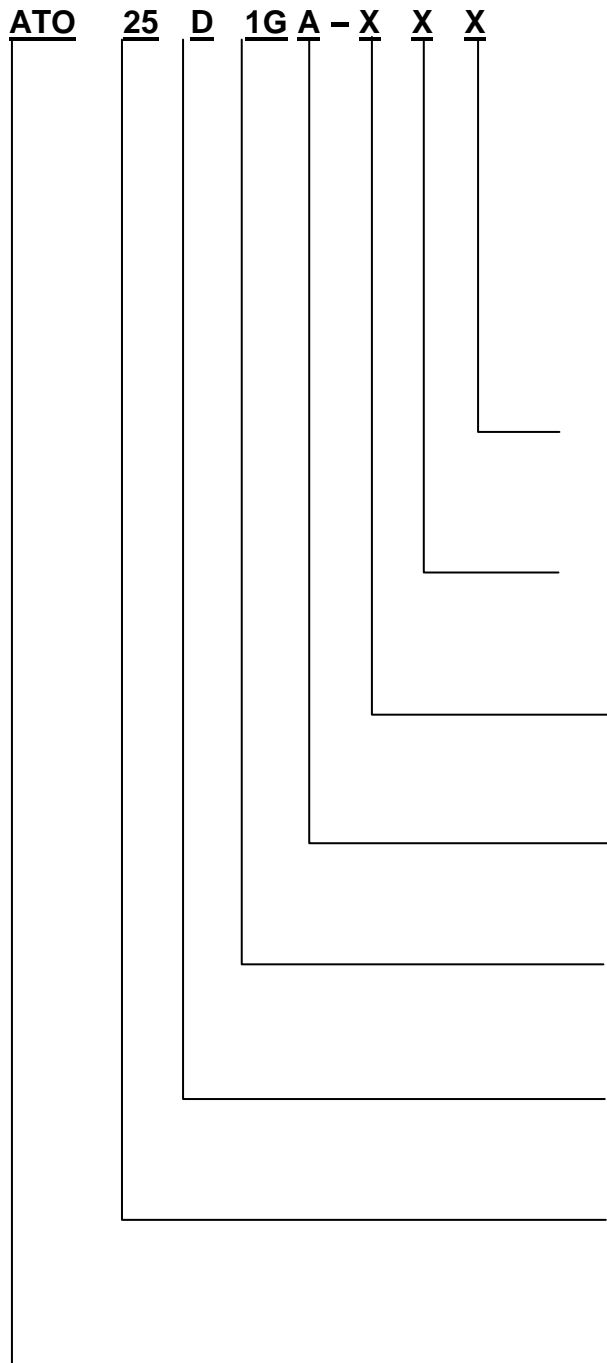

Package Type

- A = 8-pin SOIC 208mil
- B = 16-pin SOIC 300mil
- C = 8-pad WSON 6x5mm
- D = 8-pad WSON 8x6mm
- W=Wafer

Temperature Range

- C = 0°C ~ 70°C
- E = -30°C ~ 85°C
- I = -45°C ~ 85°C

Speed

- 30 = 30MHz
- 75 = 75MHz
- 10 = 104MHz

Generation

- A = 1st Gen.
- B = 2nd Gen.
- C = 3rd Gen.

Device Density

512 / 1G = 512Mbit / 1Gbit

Operating Voltage

- F = 1.8V Single voltage. 1.65V ~ 2V
- D = 3.0V Single voltage. 2.7V ~ 3.6V
- R = 3.0V Single Regulated voltage. 3.0V ~ 3.6V

Device Type

25 = SPI interface Serial Flash Memory

Manufacture Company

ATO = ATO Solution Flash Memory