

REVISIONS				
P.	LTM	DESCRIPTION	DATE	OWN APVD
G		REV PER ECR-14-016951	11FEB2015	J.T W.H

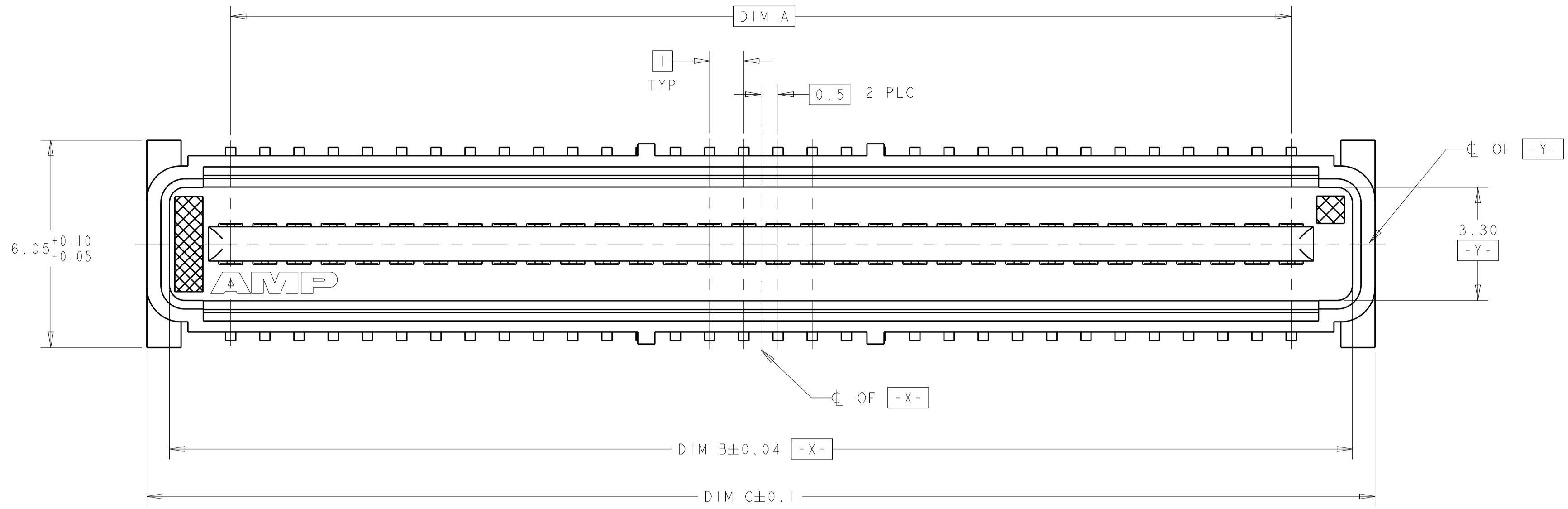

1. HOUSING MATERIAL: LIQUID CRYSTAL POLYMER, COLOR; BLACK, CONTACT MATERIAL: PHOSPHOR BRONZE.
2. CONTACT FINISH: NICKEL UNDERPLATE ALL OVER, MATING SURFACES PLATED TO MEET PLI PERFORMANCE REQUIREMENTS OF INDUSTRY SPECIFICATION EIA-700AAAAB, SOLDER TAILS PLATED TIN-LEAD.
3. DATUM LOCATIONS AND BASIC DIMENSIONS TO BE ESTABLISHED BY THE CUSTOMER. CONSULT AMP ENGINEERING WHEN PLACING MULTIPLE CONNECTORS ON A PC BOARD.
4. PACKAGED IN TAPE ON REELS PER EIA-481.
5. 1.5 MIN DIAMETER HOLE SHOULD BE USED IF USING POST STYLE "A" AND PLACING ON PCB WITH VACUUM PLACEMENT EQUIPMENT.
6. SHORTER SOLDER LANDS MAY BE USED PER EIA 700AAAAB, HOWEVER 2.7 LENGTH ASSURES OPTIMUM SOLDER FILLET REGARDLESS OF MANUFACTURER OF CONNECTOR.
7. REFERRED TO AS DIM N IN EIA 700AAAAB SPECIFICATION.
8. CONTACT FINISH: 0.002 MINIMUM BRIGHT TIN-LEAD (93-7) ON SOLDER AREA, 0.00127 MINIMUM GOLD ON MATING AREA, BOTH OVER 0.00127 MINIMUM NICKEL ON ENTIRE CONTACT.
9. OBSOLETE PART NUMBER.
10. SQUARE AND DIAMOND SHAPED POSTS
11. ROUND SHAPED POSTS

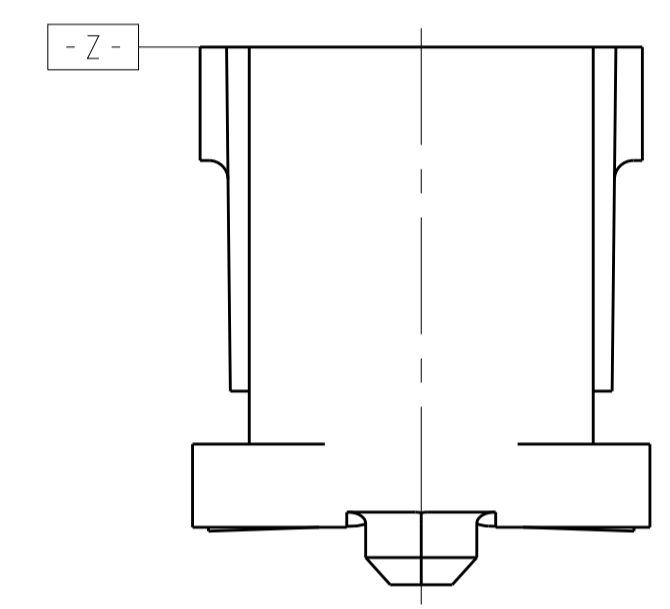
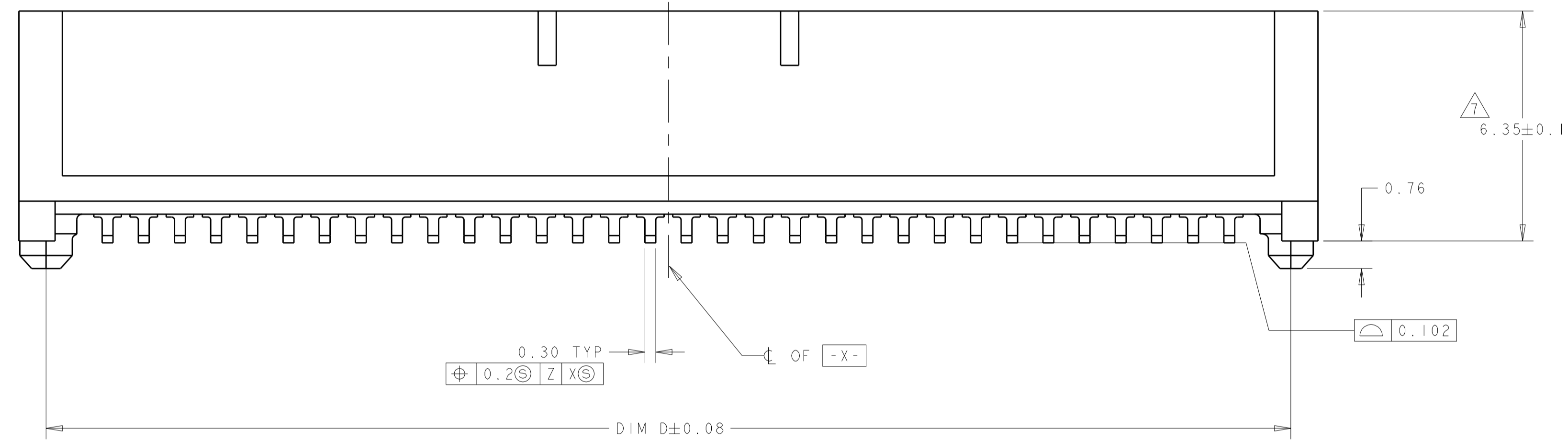

10 STYLE A POST

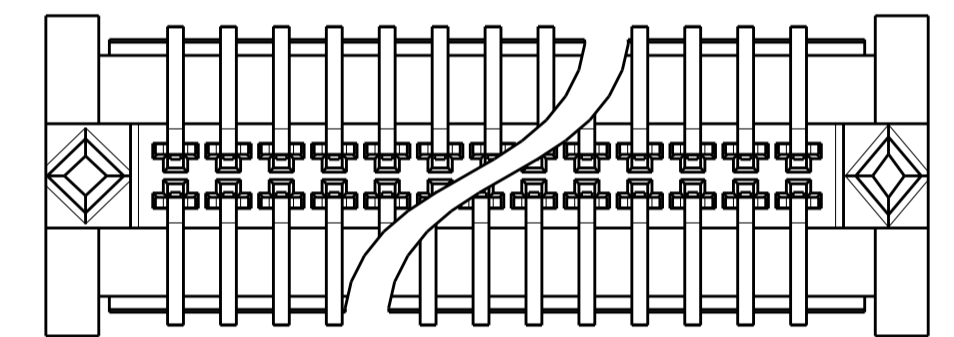

11 STYLE B POST

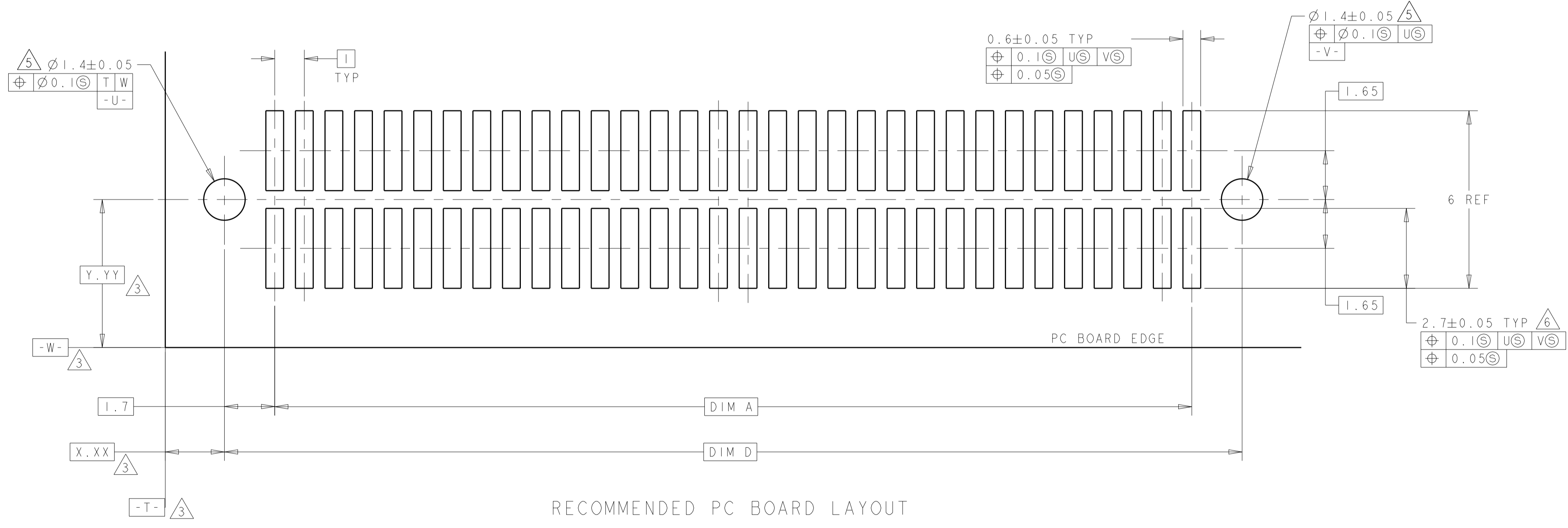
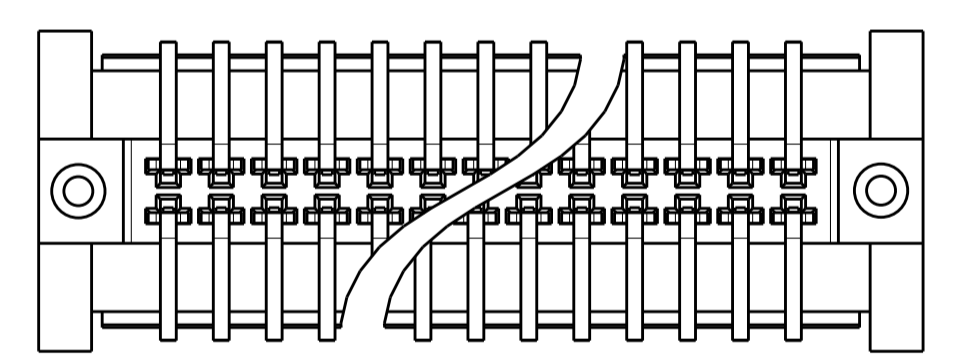

RECOMMENDED PC BOARD LAYOUT

POST STYLE	FINISH	DIM D	DIM C	DIM B	DIM A	STACK HGTS	POS	PART NO
11	8	44.4	45.9	44.58	41	8	84	3-120525-2
11	8	34.4	35.9	34.58	31	8	64	3-120525-1
11	2	44.4	45.9	44.58	41	8	84	2-120525-2
11	2	34.4	35.9	34.58	31	8	64	2-120525-1
10	8	44.4	45.9	44.58	41	8	84	1-120525-2
10	8	34.4	35.9	34.58	31	8	64	1-120525-1
9	10	44.4	45.9	44.58	41	8	84	120525-2
9	10	34.4	35.9	34.58	31	8	64	120525-1

THIS DRAWING IS A CONTROLLED DOCUMENT. DWN J. REED 2/11/97
 CHK L. VO 2/11/97
 APVD -

TE TE Connectivity

PRODUCT SPEC: 502-1079
 APPLICATION SPEC: 114-25045

NAME: PLUG ASSY, 1.0mm FH (IEEE1386)
 CONNECTOR

SIZE: A1 CAGE CODE: 120525 DRAWING NO: 120525-2
 WEIGHT: -

MATERIAL: SEE TABLE
 FINISH: -

CUSTOMER DRAWING SCALE: 10:1 SHEET: 1 OF 1 REV: G