



Data Sheet



telephone
949 252 0522



BACK

Product Category: VCXO

Series Number	Package	Description	Last Modified
551	8 Pin DIP	HCMOS / TTL	Jan. 01 2007

FEATURES

- Wide voltage control range
- HCMOS or TTL output
- Industry standard DIP 8 pin lead spacing
- RoHs / Lead Free compliant 



OPERATING CONDITIONS / ELECTRICAL CHARACTERISTICS

PARAMETERS	CONDITIONS	CHARACTERISTICS		UNITS
Output Logic	-	HCMOS / TTL Output		-
Input Voltage (VDD)	-	3.3 ±10%	5.0 ±10%	VDC
Frequency Range (f ₀)	-	1.5440 ~ 155.520		MHz
Operating Temperature (T _{OPR})	-	0 ~ +70 (Std.) / -40 ~ 85 (Option)		°C
Storage Temperature (T _{STG})	-	-55 ~ +125		°C
Overall Frequency Stability	a + b + c + d	±20, ±25, ±50, ±100 max.		PPM
	(a) Frequency Tolerance	Inclusive of Overall Stability		-
	(b) Temperature Stability	Inclusive of Overall Stability (Operating Temperature)		-
	(c) Input Voltage Stability	Inclusive of Overall Stability (VDD ±5%)		-
	(d) Load Stability	Inclusive of Overall Stability (RL ±5%)		-
Input Current (I _{DD})	-	10 ~ 20 max.	20 ~ 50 max.	mA
Aging	@ 25°C	±5 max.		PPM/Y
Rise Time (T _R) / Fall Time (T _F)	-	5 max. (0.4V to 2.4V / TTL; 20% to 80% / HCMOS)		nS
Pin 1 Control Voltage Range	-	1.65 ±1.35	2.5 ±2	V
Output Voltage High "1" VOH	TTL Load	2.4 min.		VDC
	HCMOS Load	2.7 min.	VDD-0.5 min.	
Output Voltage Low "0" VOL	TTL Load	0.4 max.		VDC
	HCMOS Load	0.5 max.		
Duty Cycle	-	50 ±10 (Std.) / 50 ±5 (Option)		%
Start-Up Time (T _S)	-	10 max.		ms
Jitter	(One Sigma)	±25 max. (< 52MHz); ±50 max. (> 52MHz)		ps
Linearity	-	±20 (Std.) / ±10, ±5 (Option)		%

PIN CONNECTIONS	
#1	Voltage Control
#4	CASE GND

PACKAGE DIMENSIONS (mm)

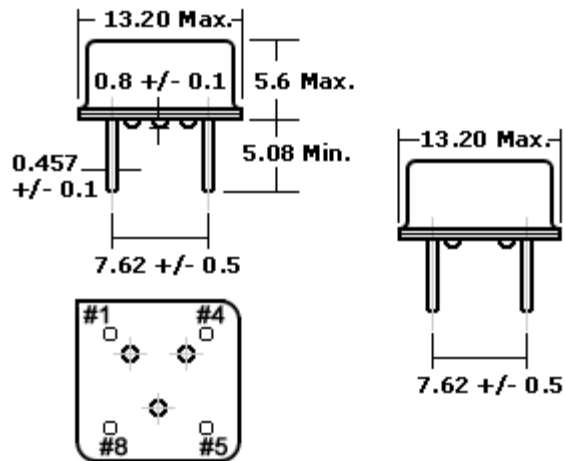

#5	OUTPUT
#8	VDD

PART NUMBER GUIDE

Series Number	Frequency	Voltage Supply Option	Frequency Tolerance & Stability (max.)	Operating Temp. (°C)	Duty Cycle	Pulling Range	Linearity
551	- 12.0 M	- 3	E	N	- T	P1	20
Oscilent VCXO	Enter your desired frequency e.g. 12.0M for 12.000 MHz	5 = 5VDC 3 = 3.3VDC	D = ±100 PPM E = ±50 PPM F = ±25 PPM G = ±20 PPM	Blank* = 0~+70 N = -40~+85	Blank*= 50±10% T = 50±5%	P1 = 50PPM P2 = 100PPM P3 = 150PPM	20 = 20% 10 = 10% 05 = 5%
<p>NOTE: - Deviations on all parameters available. Please consult Oscilent for details. DEFINITIONS: - Click on the characteristic names above for definitions of that particular characteristic. *STANDARDS: - "Blank" part number selections indicate standard variables for that particular characteristic. GULL WING: - Add -G for Gull Wing at end of part number PACKAGING: - Standard tube packaging, add -TR for Tape/Reel. Click here for tape/reel specifications</p>							

Oscilent Corporation - CALL **949.252.0522**

Series No.: **551**

18195 East McDermott Street , Building D , Irvine , CA 92614 , USA
 Fax: 949.252.0599 , E-Mail: Sales@Oscilent.com