

# CXA1191 LINEAR INTEGRATED CIRCUIT

## FM/AM Radio

### DESCRIPTION

The CXA1191 is a one-chip FM/AM radio IC designed for radio-cassette tape recorders and headphone tape recorders.

### FEATURES

- \*Small number of peripheral components
- \*Low current consumption ( $V_{CC}=3V$ )
  - FM:  $I_D=5.3mA$  (Typ.)
  - AM:  $I_D=3.4mA$  (Typ.)
- \*Built-in FM/AM select switch
- \*Large current of AF amplifier

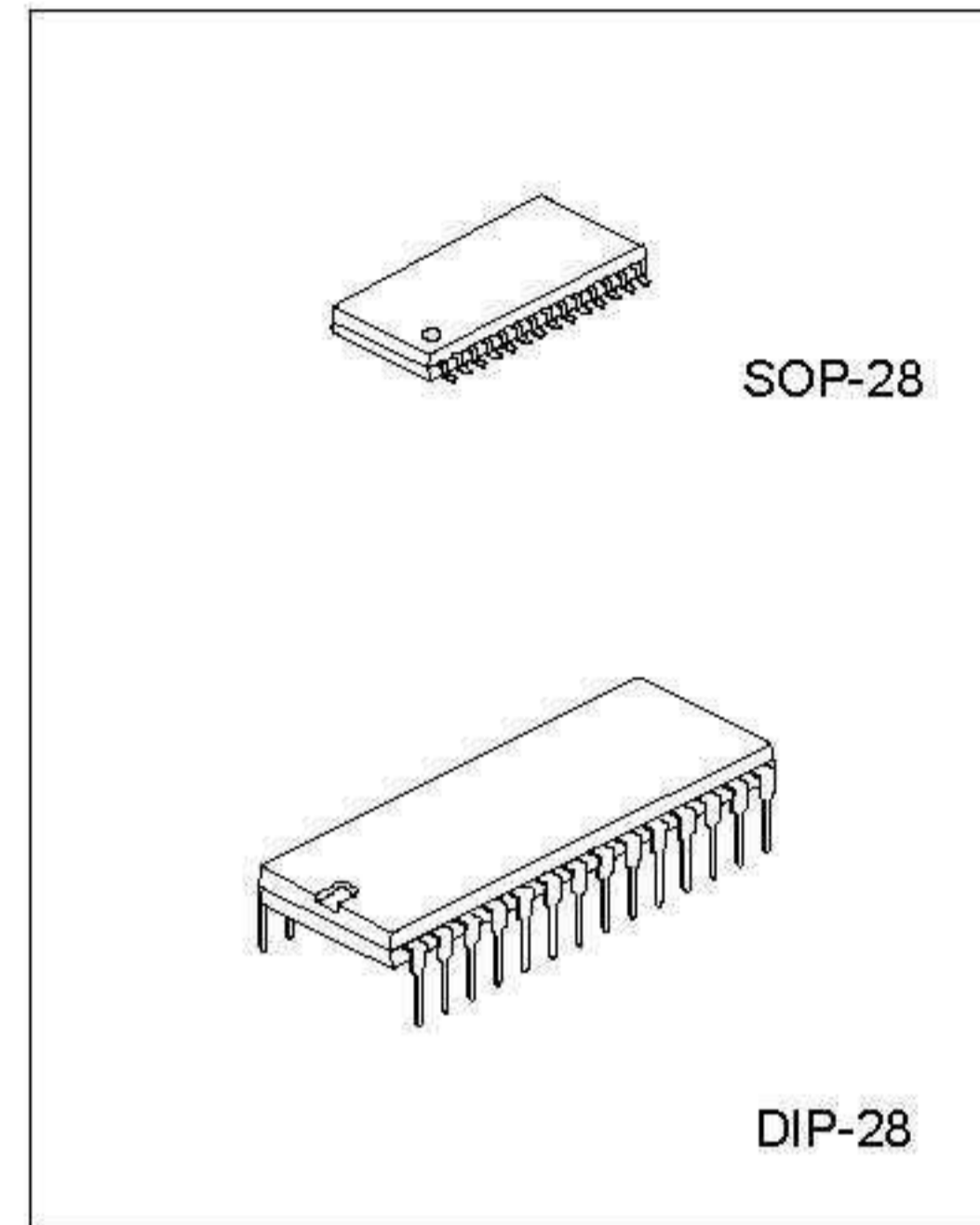

### FUNCTIONS

#### FM section

- RF amplifier, Mixer and OSC  
(incorporating AFC variable capacitor)
- IF amplifier
- Quadrature detection
- Tuning LED driver

#### AM section

- RF amplifier, Mixer and OSC (with RF AGC)
- IF amplifier (with IF AGC)
- Detector
- Tuning LED driver

#### AF section

- Electronic volume control
- FM muting

#### Structure

- Bipolar silicon monolithic IC

### ABSOLUTE MAXIMUM RATINGS( $T_a=25^\circ C$ )

PARAMETER	SYMBOL	VALUE	UNIT
Supply voltage	$V_{CC}$	9	V
Operating temperature	$T_{opr}$	-10 ~ +60	$^\circ C$
Storage temperature	$T_{stg}$	-50 ~ +125	$^\circ C$
Allowable power dissipation	$P_D$	700 (SOP-28) 1000 (DIP-28)	mW

# CXA1191 LINEAR INTEGRATED CIRCUIT

## RECOMMENDED OPERATING CONDITIONS

PARAMETER	SYMBOL	VALUE	UNIT
Supply voltage	V <sub>cc</sub>	2 ~ 7.5 (SOP-28)	V
	V <sub>cc</sub>	2 ~ 8.5 (DIP-28)	V

## BLOCK DIAGRAM

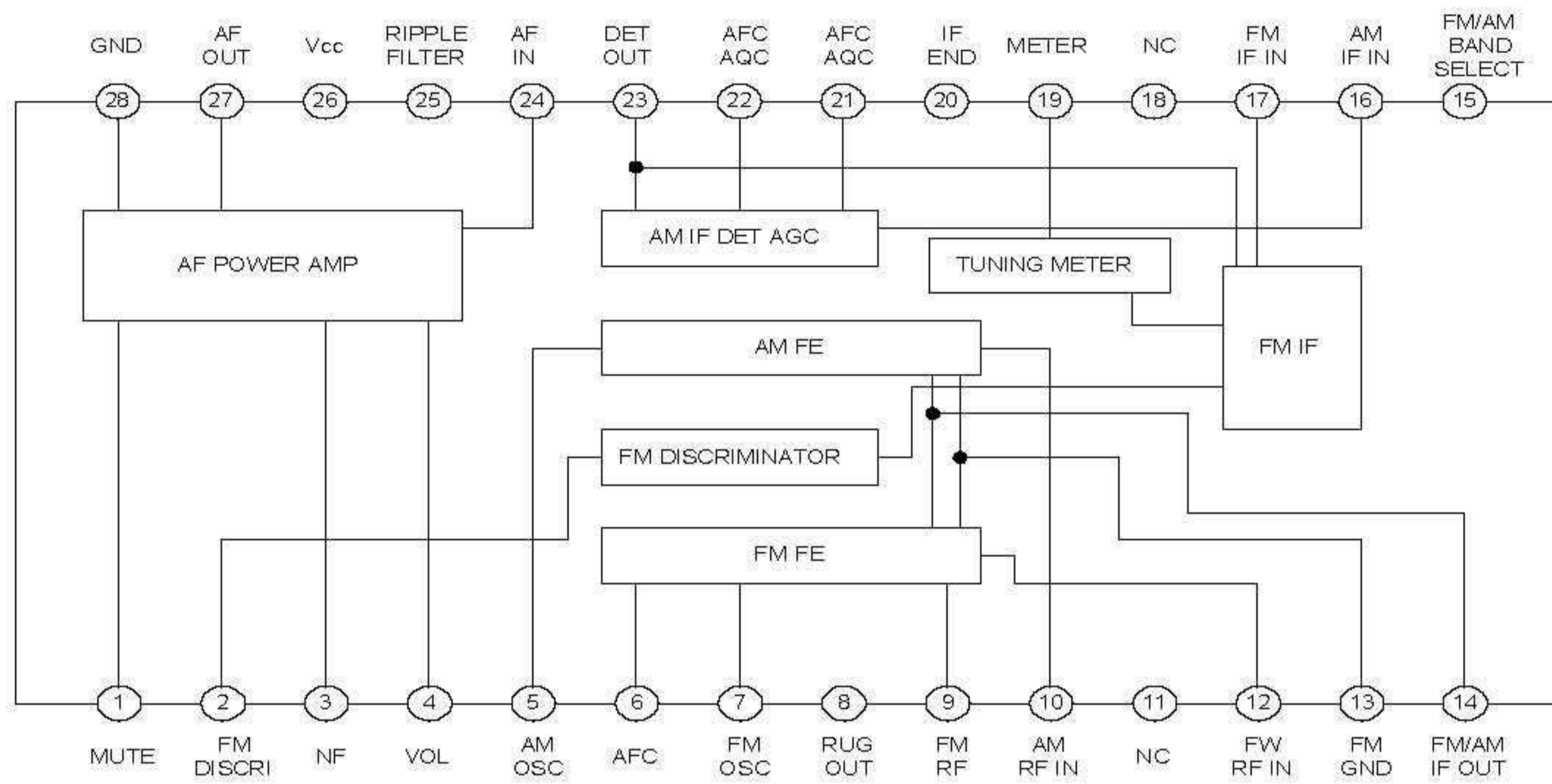

# CXA1191 LINEAR INTEGRATED CIRCUIT

## PIN CONFIGURATIONS

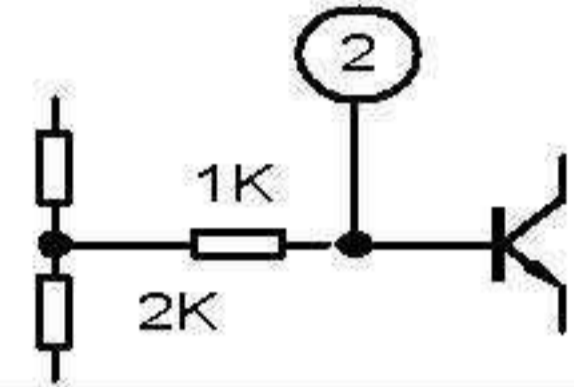
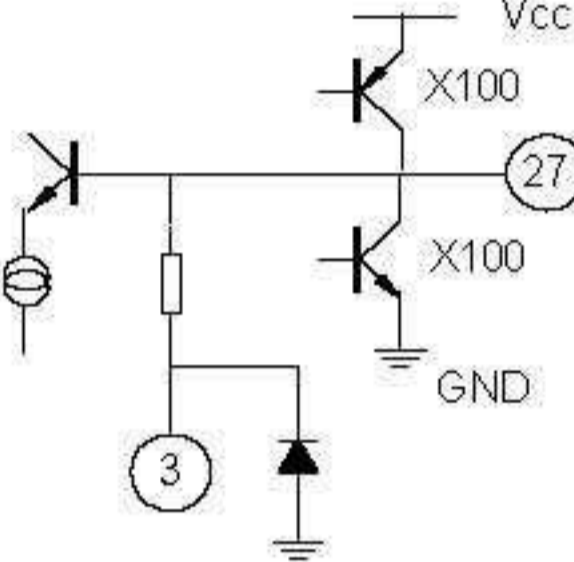
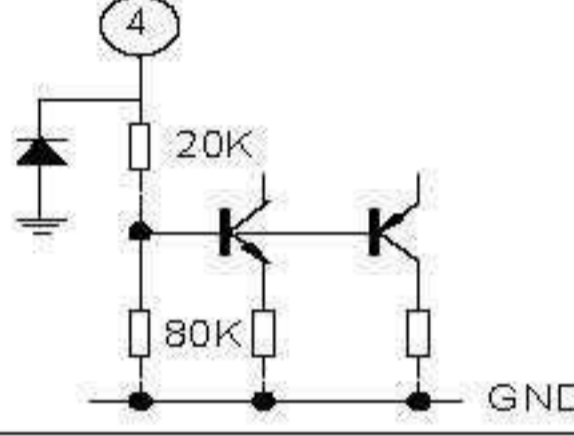
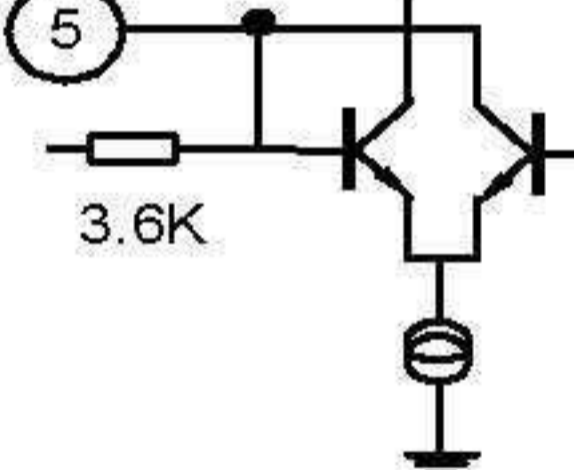
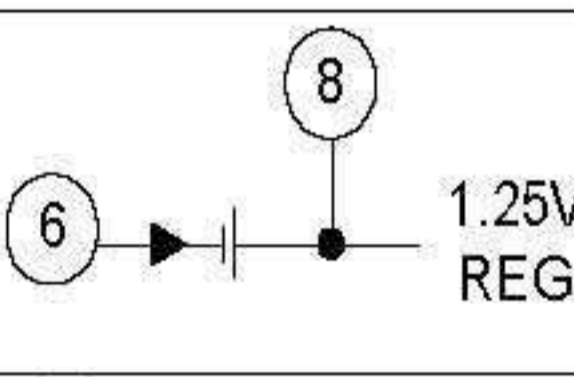
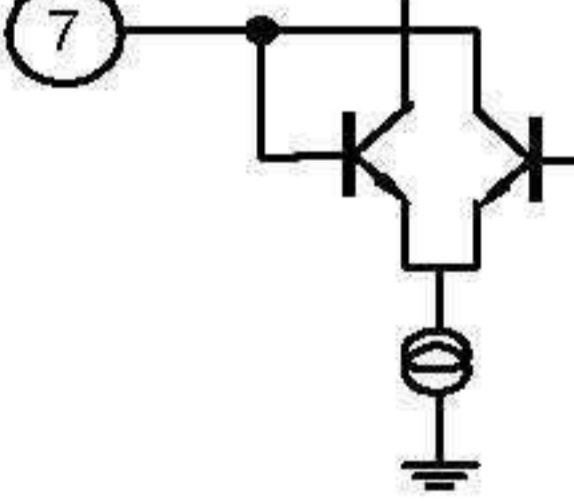
PIN	SYMBOL	VOLTAGE(V)				EQUIVALENT CIRCUIT	DESCRIPTION
		V <sub>cc</sub> =3V		V <sub>cc</sub> =6V			
		FM	AM	FM	AM		
1	MUTE	0	0	0	0		
2	FM DISCRI	2.18	2.7	4.88	5.43		Phase-shift circuit, Connect ceramic discriminator.
3	NF	1.5	1.5	3.0	3.0		Negative feedback pin Power amplifier output pin
27	AF OUT	1.5	1.5	3.0	3.0		
4	VOL CONT	1.25	1.25	1.25	1.25		Connect variable resistor for electronic volume control.
5	AM OSC	1.25	1.25	1.25	1.25		AM local oscillation circuit
6	AFC	1.25	*	1.25	*		AFC variable capacitor pin
8	REG OUT	1.25	1.25	1.25	1.25		Regulator pin 1.25V (Typ.)
7	FM OSC	1.25	1.25	1.25	1.25		FM local oscillation circuit

# CXA1191 LINEAR INTEGRATED CIRCUIT

9	FM RF	1.25	1.25	1.25	1.25		Connect FM RF tuning coil.
12	FM RF IN	0.3	0	0.3	0		FM RF input pin
10	AM RF IN	1.25	1.25	1.25	1.25		AM RF input
11	NC	0	0	0	0		
13	GND (FE GND)	0	0	0	0		
14	FM/AM FE OUT	0.36	0.2	0.36	0.2		IF output pin of FM and AM, Connect IF filter
15	BAND SELECT	0.84	0	0.88	0		FM and AM bands selection switch pin. During GND it becomes AM and during open it becomes FM.
16	AM IF IN	0	0	0	0		Input pin of AM IF
17	FM IF IN	0.34	0	0.88	0		Input pin of FM IF
18	NC	0	0	0	0		

# CXA1191 LINEAR INTEGRATED CIRCUIT

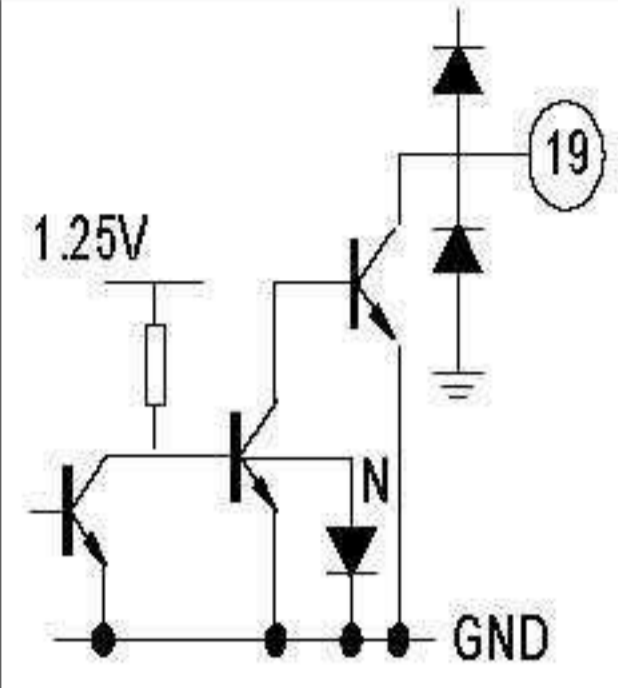
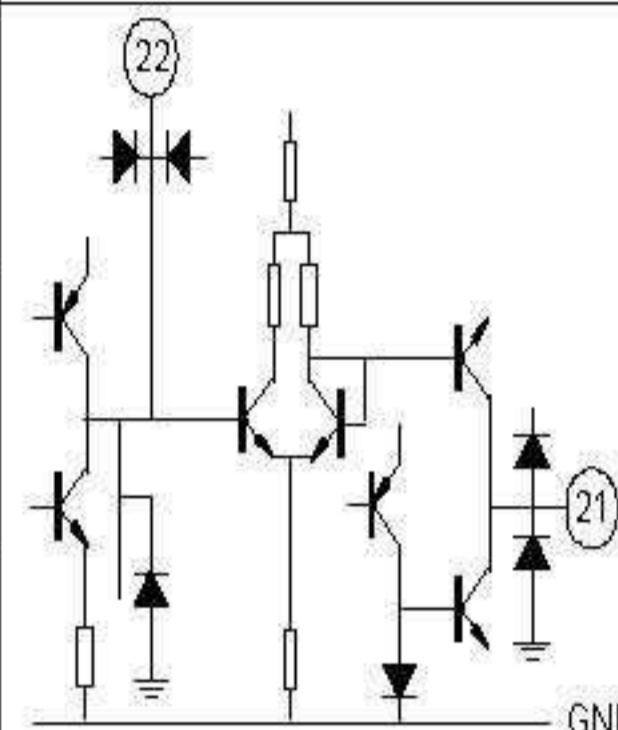
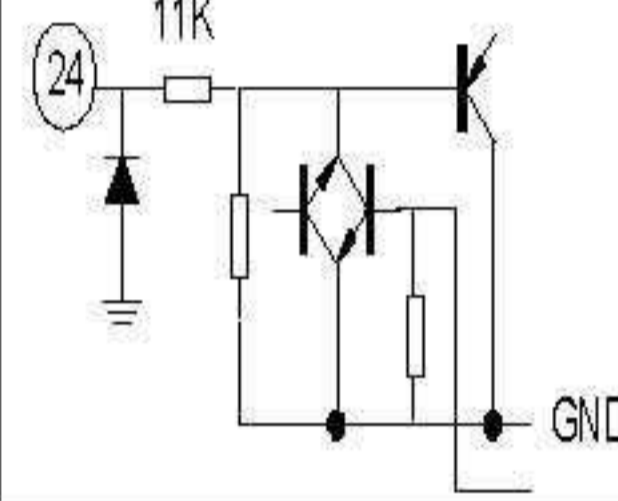
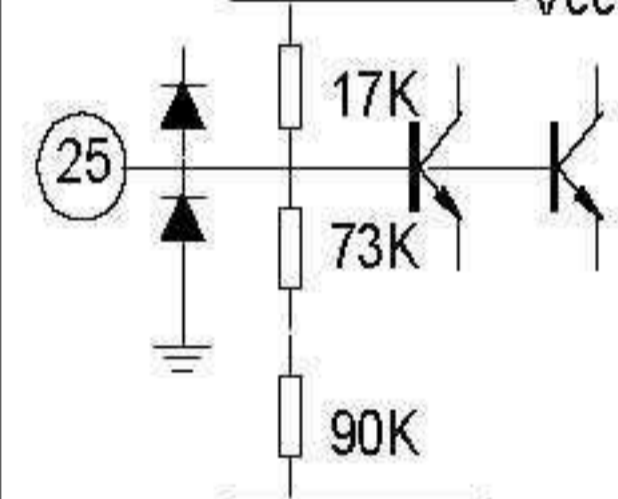
19	METER	1.6	1.6	4.5	4.5		Meter drive circuit (For tuning indicator)
20	GND	0	0	0	0		
21	AFC/AGC	1.25	1.49	1.25	1.49		AFC pin of W band. During AM, it determines time constant of AGC.
22	AFC/AGC	1.25	1.25	1.25	1.25		AFC pin of J band. During AM, it determines time constant of AGC.
23	DET OUT	1.25	1.0	1.25	1.0		Detection output pin
24	AF IN	0	0	0	0		Power amplifier input pin
25	RIPPLE FILTER	2.71	2.71	5.4	5.4		Ripple filter
26	Vcc	3.0	3.0	6.0	6.0		Power supply pin
28	GND	0	0	0	0		Power GND

\*Note: The pin voltage of pin 6 during AM, it is the same pin voltage of pin22 (23) during J BAND and is the same pin voltage of pin 21 (22) during W BAND.

# CXA1191 LINEAR INTEGRATED CIRCUIT

## ELECTRICAL CHARACTERISTICS (Ta=25°C, Vcc=6V)

NO	ITEM	SYMBOL	SW CONDITIONS						TEST POINT	CONDITIONS	MIN	TYP	MAX	UNIT
			1	2	3	4	5	6						
1	AM circuit current	ID1	A	B	A	A	A	A	IA	No signal, AM	-	3.5	10.0	mA
2	FM circuit current	ID2	A	B	A	A	B	A	IA	No signal, FM	-	7.0	14.0	mA
3	FM front end voltage gain	GV1	A	B	A	A	B	A	VA	V <sub>IN</sub> =40dBμV, 100MHz	32	39	46	dB
4	FM detection output level	VD1	A	-	-	A	B	A	VD	V <sub>IN</sub> =90dBμV, 10.7 MHz (1 kHz, 22.5kHz DEV)	39	77.5	155	V <sub>rms</sub>
5	FM IF knee level	VD2	A	-	-	A	B	A	VD	V <sub>IN</sub> level at a point 3 dB down from V <sub>IN</sub> =90dBμV, 10.7 MHz (1 kHz, 22.5kHz DEV)	-	24	32	dBμV
6	FM detection output distortion factor	THD1	A	-	-	A	B	A	VD	V <sub>IN</sub> =90dBμV, 10.7 MHz (1 kHz, 75kHz DEV)	-	0.3	2.0	%
7	FM meter current	IB1	A	-	-	A	B	A	IM	V <sub>IN</sub> =60dBμV, 10.7 MHz	1.8	3.5	7.0	mA
8	AM front end voltage gain	GV2	A	A	A	A	A	A	VB	V <sub>IN</sub> =60dBμV, 1660 kHz	15	22	29	dB
9	AM IF voltage gain	GV3	A	A	-	A	A	A	VD	V <sub>IN</sub> when 455kHz (1kHz, 30% MOD) output is -34dBm	14	20	27	dBμV
10	AM detection output level	VD3	A	A	-	A	A	A	VD	V <sub>IN</sub> =85dBμV, 455kHz (1kHz, 30% MOD)	39	77.5	155	V <sub>rms</sub>
11	AM meter current	IB2	A	A	-	A	A	A	IM	V <sub>IN</sub> =85dBμV, 455kHz (1kHz, 30% MOD)	1.3	3.0	7.0	mA
12	AM detection output distortion factor	THD2	A	A	B	B	A	A	VD	V <sub>IN</sub> =60dBμV, 1660kHz (1kHz, 30% MOD), Vcc=7.8V	-	0.6	2.0	%
13	Audio voltage gain	GV4	A	-	-	-	-	B	VE	V <sub>IN</sub> =60dBμV, 10.7MHz V <sub>IN</sub> =-30dBμV, 1kHz	27	31.5	36	dB
14	Audio distortion factor	THD3	A	-	-	-	-	B	VE	Distortion factor for output of 50mV V <sub>IN</sub> =60dBμV, 10.7MHz V <sub>IN</sub> =-20dBμV, 1kHz	-	0.3	2.5	%
15	Muting level	VD4	A	-	-	-	-	B	VE	Muting level for 50 mW output V <sub>IN</sub> =-20dBm, 1kHz V <sub>IN</sub> OFF	8	15	22	dB

0dBμV=1μV

# CXA1191 LINEAR INTEGRATED CIRCUIT

## APPLICATION CIRCUIT

