

Features

- ESD Protect for 4 high-speed I/O channels
- Provide ESD protection for each line to
IEC 61000-4-2 (ESD) $\pm 15\text{kV}$ (air), $\pm 8\text{kV}$ (contact)
IEC 61000-4-4 (EFT) 20A (5/50ns)
IEC 61000-4-5 (Lightning) 3A (8/20 μs)
- For low operating voltage of 3.3V and below
- Ultra low capacitance: 0.18pF typical
- Fast turn-on and ultra-low clamping voltage
- Array of ESD rated diodes with internal equivalent TVS (Transient Voltage Suppression) diode
- Solid-state silicon-avalanche and active circuit triggering technology
- **Green part**

Applications

- HDMI 1.3 & 1.4, and 2.0 version
- DisplayPort 1.1 & 1.2 and 1.3 version
- USB3.0 & 3.1 interfaces
- USB Type-C interface
- SATA and eSATA interfaces
- Hand Held Portable Applications

Description

AZ1023-04F is a design which includes ESD rated diode arrays to protect high speed data interfaces. The AZ1023-04F has been specifically designed to protect sensitive components which are connected to data and transmission lines from over-voltage damage caused by Electrostatic Discharging (ESD), Electrical Fast Transients (EFT), and Cable Discharge Event (CDE).

AZ1023-04F is a unique design which includes ESD rated, ultra low capacitance steering diodes and a unique design of clamping cell which is an equivalent TVS diode in a single package. During transient conditions, the steering diodes direct the transient to either the internal ESD line or to ground line. The internal unique design of clamping cell prevents over-voltage on the internal ESD line and on the I/O line, which is protecting any downstream components.

AZ1023-04F may be used to meet the ESD immunity requirements of IEC 61000-4-2, Level 4 ($\pm 15\text{kV}$ air, $\pm 8\text{kV}$ contact discharge).

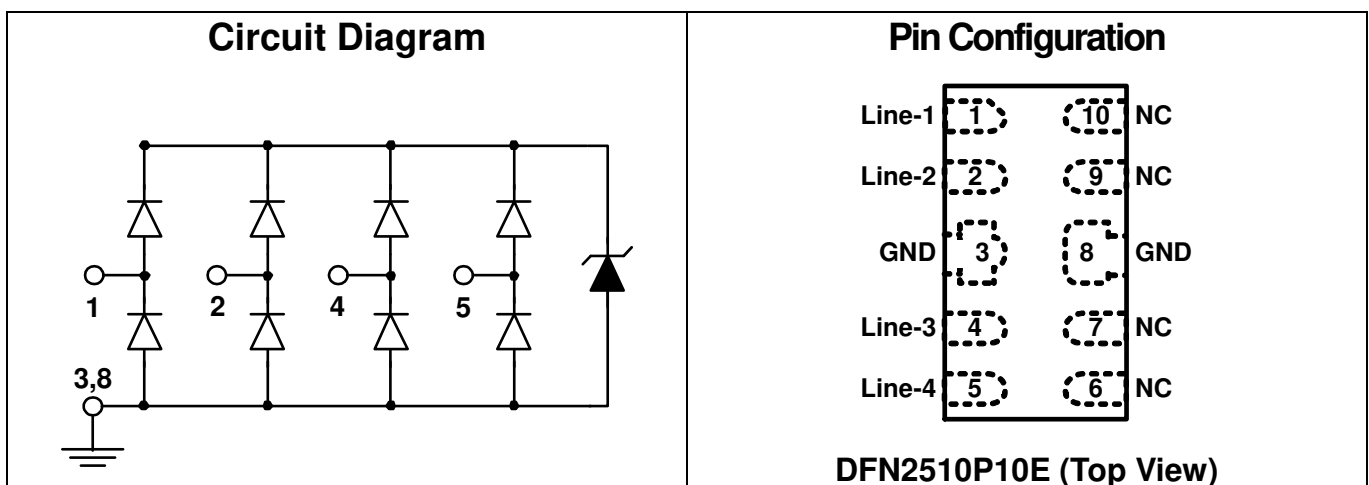

SPECIFICATIONS

ABSOLUTE MAXIMUM RATINGS			
PARAMETER	SYMBOL	RATING	UNITS
Peak Pulse Current (tp =8/20μs)	I _{PP}	3	A
Operating Voltage (I/O pin-GND)	V _{DC}	3.6	V
ESD per IEC 61000-4-2 (Air)	V _{ESD-1}	±15	kV
ESD per IEC 61000-4-2 (Contact)	V _{ESD-2}	±8	
Lead Soldering Temperature	T _{SOL}	260 (10 sec.)	°C
Operating Temperature	T _{OP}	-55 to +85	°C
Storage Temperature	T _{STO}	-55 to +150	°C

ELECTRICAL CHARACTERISTICS						
PARAMETER	SYMBOL	CONDITIONS	MIN	TYP	MAX	UNITS
Reverse Stand-Off Voltage	V _{RWM}	Pin-1,-2,-4,-5 to pin-3,-8, T=25 °C.			3.3	V
Channel Leakage Current	I _{CH-Leak}	V _{Pin-1,-2,-4,-5} = 3.3V, V _{Pin-3,-8} = 0V, T=25 °C.			0.5	μA
Reverse Breakdown Voltage	V _{BV}	I _{BV} = 1mA, T=25 °C, Pin-1,-2,-4,-5 to pin-3,-8.	4.5		7.5	V
Forward Voltage	V _F	I _F = 15mA, T=25 °C, pin-3,-8 to pin-1,-2,-4,-5.		0.9	1.2	V
ESD Clamping Voltage (Note. 1)	V _{clamp}	IEC 61000-4-2 +8kV (I _{TLP} = 16A), Contact mode, T=25 °C, I/O pin to Ground.		11		V
ESD Dynamic Turn-on Resistance	R _{dynamic}	IEC 61000-4-2, 0~+8kV, T=25 °C, Contact mode, any I/O pin to Ground.		0.4		Ω
Channel Input Capacitance	C _{IN}	V _{pin-3,-8} = 0V, V _{IN} = 1.65V, f = 1MHz, T=25 °C, any I/O pin to Ground.		0.18	0.3	pF
Channel to Channel Input Capacitance	C _{CROSS}	V _{pin-3,-8} = 0V, V _{IN} = 1.65V, f = 1MHz, T=25 °C, between I/O pins.		0.04	0.08	pF

Note 1: ESD Clamping Voltage was measured by Transmission Line Pulsing (TLP) System.

TLP conditions: Z₀= 50Ω, t_p= 100ns, t_r= 1ns.



Typical Characteristics

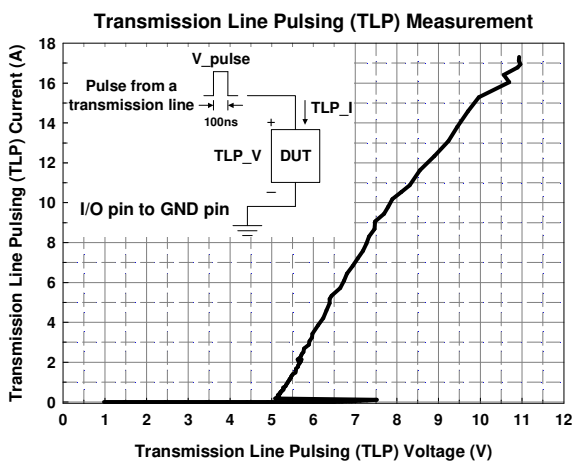
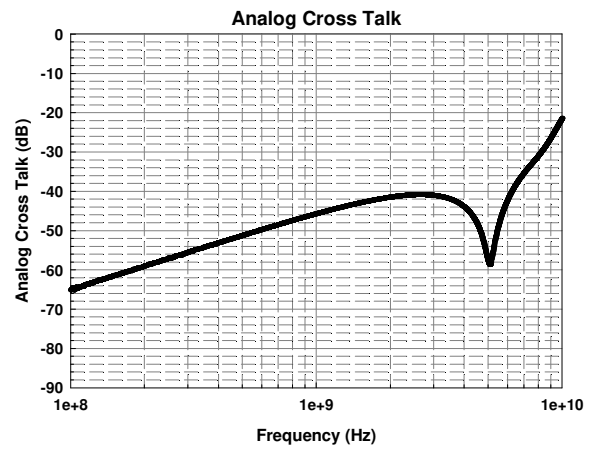
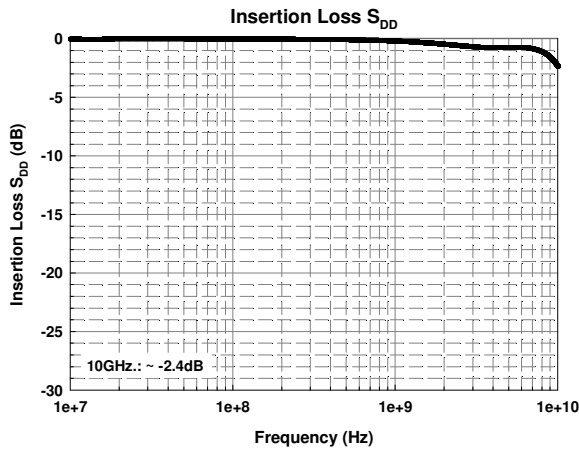
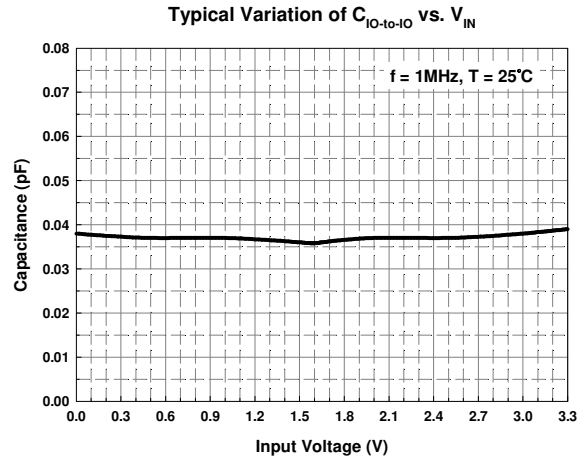
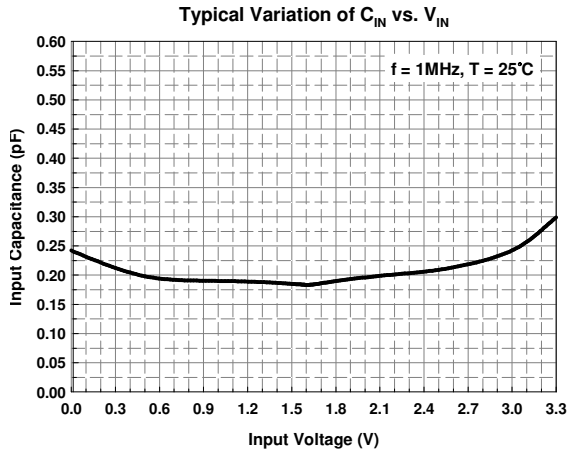

Applications Information

The AZ1023-04F is designed to protect four data lines from transient over-voltage (such as ESD stress pulse). The device connection of AZ1023-04F is shown in the Fig. 1. In Fig. 1, the four protected data lines are connected to the ESD protection pins (pin1, pin2, pin4, and pin5) of AZ1023-04F. The ground pins (pin3 and pin8) of AZ1023-04F are the negative reference pins.

These pins should be directly connected to the GND rail of PCB (Printed Circuit Board). To get minimum parasitic inductance, the path length should keep as short as possible.

AZ1023-04F can provide ESD protection for 4 I/O signal lines simultaneously. If the number of I/O signal lines is less than 4, the unused I/O pins can be simply left as NC pins.

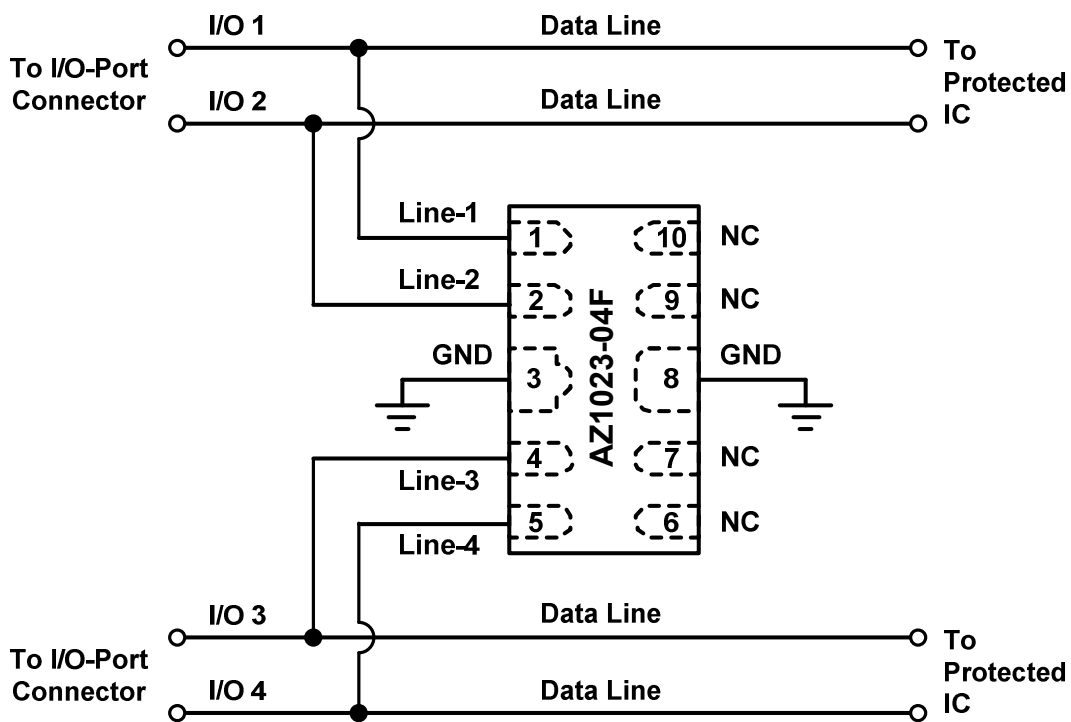
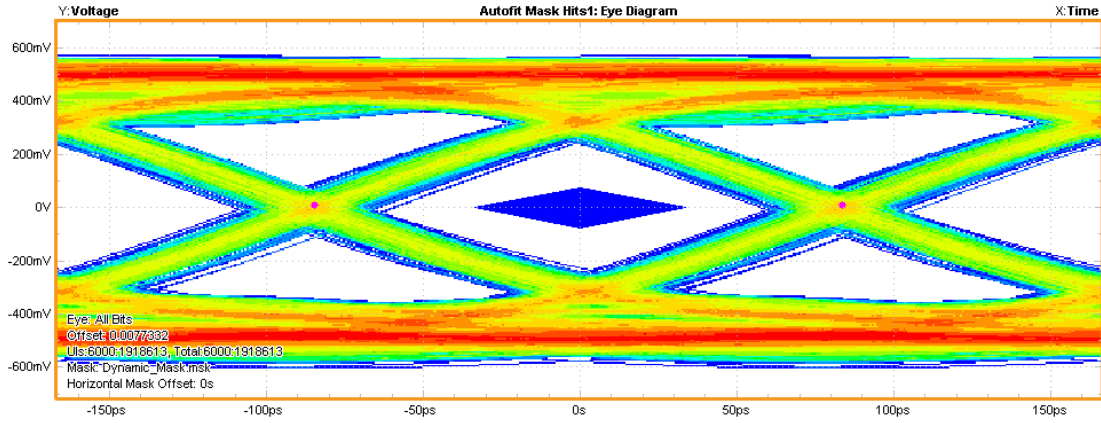
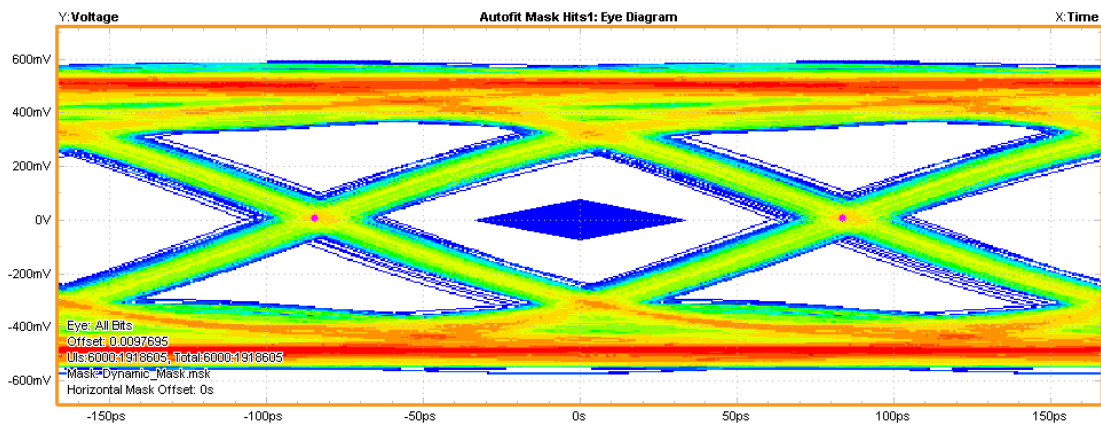

Fig. 1 Data lines connection of AZ1023-04F.

Fig. 2 shows the HDMI 2.0 (6 Gb/s) eye diagrams with and without AZ1023-04F. Due to ultra low capacitance of AZ1023-04F, no degradation is observed.



Without AZ1023-04F



With AZ1023-04F

Fig. 2 HDMI 2.0 (6 Gb/s) Eye Diagrams with and without AZ1023-04F.



PACKAGE OUTLINE
(DFN2510P10E)

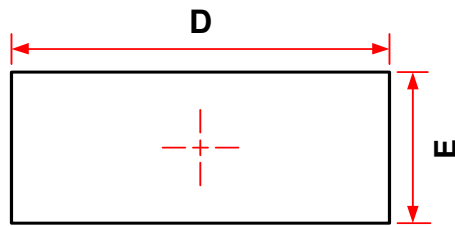

TOP VIEW (unit in mm)

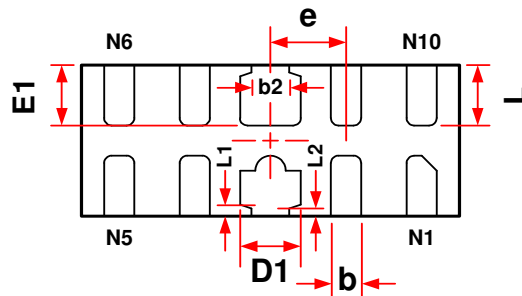

BOTTOM VIEW (unit in mm)

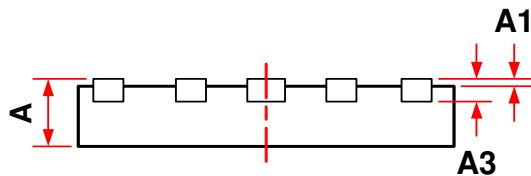

SIDE VIEW (unit in mm)

Symbol	Millimeters		Inches	
	min	max	min	max
A	0.40	0.55	0.016	0.022
A1	0.00	0.05	0.000	0.002
A3	0.152REF.		0.006 BSC	
D	2.45	2.55	0.096	0.100
E	0.95	1.05	0.037	0.041
D1	0.35	0.45	0.014	0.018
E1	0.35	0.45	0.014	0.018
b	0.15	0.25	0.006	0.010
e	0.5 BSC		0.020 BSC	
L1	0.075 REF		0.003 REF	
L2	0.05 REF		0.002 REF	
b2	0.20	0.30	0.008	0.012
L	0.35	0.45	0.014	0.018



LAND LAYOUT

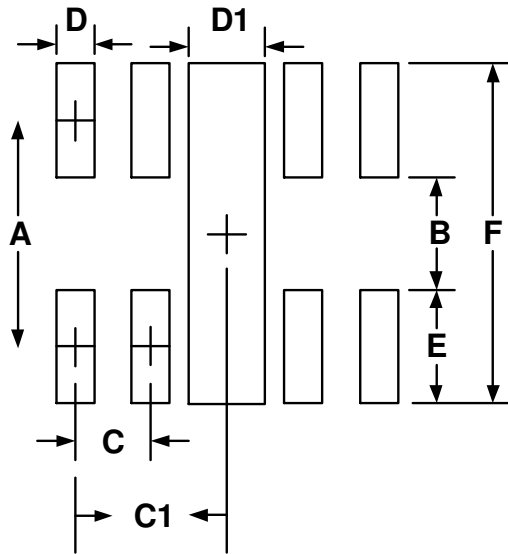

Dimensions		
Index	Millimeter	Inches
A	0.875	0.034
B	0.20	0.008
C	0.50	0.02
C1	1.00	0.039
D	0.25	0.01
D1	0.4	0.016
E	0.675	0.027
F	1.55	0.061

Notes:

This LAND LAYOUT is for reference purposes only. Please consult your manufacturing partners to ensure your company's PCB design guidelines are met.

MARKING CODE



234 = Device Code
X = Date Code
Y = Control Code

Part Number	Marking Code
AZ1023-04F.R7G (Green Part)	234XY

Note. Green means Pb-free, RoHS, and Halogen free compliant.

Ordering Information

PN#	Material	Type	Reel size	MOQ	MOQ/internal box	MOQ/carton
AZ1023-04F.R7G	Green	T/R	7 inch	3,000/reel	4 reels = 12,000/box	6 boxes = 72,000/carton



Revision History

Revision	Modification Description
Revision 2016/06/23	Preliminary Release.
Revision 2017/05/15	Formal Release.
Revision 2017/06/15	Update the Features.