

Cable connector - CA-17P1N12T007S - 1619377

Please be informed that the data shown in this PDF Document is generated from our Online Catalog. Please find the complete data in the user's documentation. Our General Terms of Use for Downloads are valid (<http://phoenixcontact.com/download>)

Cable connector, CA, angled, shielded: yes, SPEEDCON locking, M23, No. of pos.: 17, Direction of rotation: Standard, type of contact: Pin, Solder connection, cable diameter range: 6 mm ... 10 mm, coding:N



The figure shows the 12-pos. product version

Your advantages

- ✓ Angled cable outlet for confined spaces
- ✓ Can be adapted to various applications, thanks to adjustable cable outlet direction
- ✓ Safe use in the field, thanks to high degree of protection
- ✓ Connector for flexible on-site assembly
- ✓ Consistent EMC protection for reliable transmission of signals
- ✓ Reduced connection time with SPEEDCON fast locking system
- ✓ Solder connection: proven connection technology for various litz wires



Key Commercial Data

Packing unit	1 pc
GTIN	 4 046356 824705
GTIN	4046356824705

Technical data

Temperature range

Ambient temperature	-40 °C ... 125 °C
---------------------	-------------------

Data of the insulating body

Coding	N
Insulator material	PBT
Contact material	CuZn
Contact surface material	Ni/Au
Insertion/withdrawal cycles mechanical	100

Cable connector - CA-17P1N12T007S - 1619377

Technical data

Data of the insulating body

Contact connection method	Solder connection
Type of contacts	Pin
Application	Signal
Number of positions	17
Direction of rotation	Standard
Rated voltage	48 V AC
	74 V DC
Rated surge voltage	1.5 kV
Overvoltage category	III
Degree of pollution	3
Contact diameter of signal contacts	1 mm
Litz wire cross section of signal contacts max.	1 mm ²
Nominal current per signal contact	8 A

Housing data

Housing material	Metal
Type of locking	SPEEDCON locking
Degree of protection (when plugged in)	IP67
Thread type	M23

Cable seal data

Cable diameter	6 mm ... 10 mm
Sealing material	NBR

Environmental Product Compliance

REACH SVHC	Lead 7439-92-1
China RoHS	Environmentally Friendly Use Period = 50 years
	For details about hazardous substances go to tab "Downloads", Category "Manufacturer's declaration"

Drawings

Schematic diagram

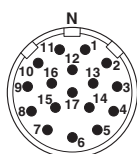

Dimensional drawing

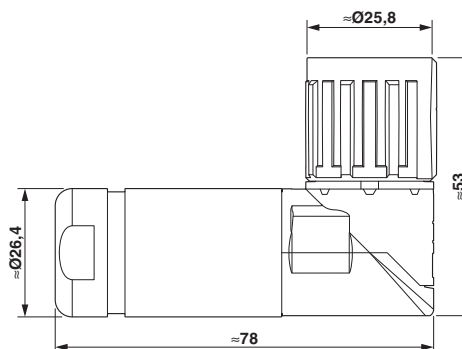

Cable connector - CA-17P1N12T007S - 1619377

Classifications

eCl@ss

eCl@ss 10.0.1	27440102
eCl@ss 11.0	27440102
eCl@ss 4.0	27260700
eCl@ss 4.1	27260700
eCl@ss 5.0	27260700
eCl@ss 5.1	27260700
eCl@ss 6.0	27260700
eCl@ss 7.0	27440102
eCl@ss 9.0	27440102

ETIM

ETIM 3.0	EC001121
ETIM 4.0	EC002635
ETIM 6.0	EC002061
ETIM 7.0	EC002635

UNSPSC

UNSPSC 6.01	43172015
UNSPSC 7.0901	43201404
UNSPSC 11	43172015
UNSPSC 12.01	43201404
UNSPSC 13.2	43201404
UNSPSC 18.0	39121413
UNSPSC 19.0	39121413
UNSPSC 20.0	39121413
UNSPSC 21.0	39121413

Approvals

Approvals

Approvals

UL Recognized / cUL Recognized / cULus Recognized

Ex Approvals

Approval details

Cable connector - CA-17P1N12T007S - 1619377

Approvals

UL Recognized		http://database.ul.com/cgi-bin/XYV/template/LISEXT/1FRAME/index.htm E335019-20141210
Nominal voltage UN		48 V
Nominal current IN		8 A
mm ² /AWG/kcmil		18

cUL Recognized		http://database.ul.com/cgi-bin/XYV/template/LISEXT/1FRAME/index.htm E335019-20141210
Nominal voltage UN		48 V
Nominal current IN		5 A
mm ² /AWG/kcmil		18

cULus Recognized	
------------------	--

Accessories

Accessories

Circular connectors (device side)

Hook wrench - SF-Z0027 - 1607455



Hook wrench

Mounting material

Torque screwdriver - SF-Z0028 - 1607456



Torque screwdriver

Cable connector - CA-17P1N12T007S - 1619377

Accessories

Color-coding - RF-Z0014 - 1620588



Color-coding, color: green

Color-coding - RF-Z0015 - 1620592



Color-coding, color: orange

Color-coding - RF-Z0016 - 1620593



Color-coding, color: black

Protective cover

Protective cap - RC-Z2058 - 1604223



Plastic protection cap for connectors with M23 knurled nut

Plastic anti-static dust protection cap - RC-Z2468 - 1611796



Plastic protection cap, antistatic, for connectors with M23 knurled nut

Phoenix Contact 2021 © - all rights reserved
<http://www.phoenixcontact.com>

PHOENIX CONTACT GmbH & Co. KG
Flachmarktstr. 8
32825 Blomberg
Germany
Tel. +49 5235 300
Fax +49 5235 3 41200
<http://www.phoenixcontact.com>