

# LH3 Torque & Multi-turn Position Sensor

SX-4300



**Features:**

- Torque and position multi-turn output
- Ideally suited for demanding electric power steering systems



## Electrical

Torque Signal Linearity	±3%
Torque Hysteresis	0.5% maximum
Torque Signal Microgradient	±30% of theoretical slope over 0.4° interval
Torque Sensed Angle	±8°
Position Signal Linearity (P1, P2)	±1.5%
Position Signal Microgradient (P1, P2)	±30% of theoretical slope over 2° interval
Multi-turn Position Accuracy (P3)	±3%
Multi-turn Position Sensed Angle	±900°
Total Resistance	420 Ω ±30%

## Mechanical

Torque Mechanical Travel	±11.4°
Position Mechanical Travel	Continuous
Turning Torque (rotor to rotor)	0.03 NM maximum
Turning Torque (position rotor to housing)	0.06 NM maximum
Weight	95 grams maximum

## Environmental

Operating Temperature Range	-40°C to +85°C
Shock	14 ms half-sine at 300 m/s <sup>2</sup>
Vibration	10 to 55 Hz with 1 mm P-P constant displacement, 120 hours each of 3 planes
Torque Rotational Life	1 million cycles
Position Rotational Life	1 million cycles
Storage Temperature Range	-40°C to +105°C

**General Note**

TT Electronics reserves the right to make changes in product specification without notice or liability. All information is subject to TT Electronics' own data and is considered accurate at time of going to print.

TT Electronics | BI Technologies  
 4200 Bonita Place, Fullerton, CA 92835-1053, USA | Ph: +1 714 447 2300  
[www.ttelectronics.com](http://www.ttelectronics.com) | [sensors@ttelectronics.com](mailto:sensors@ttelectronics.com)

## Output Charts

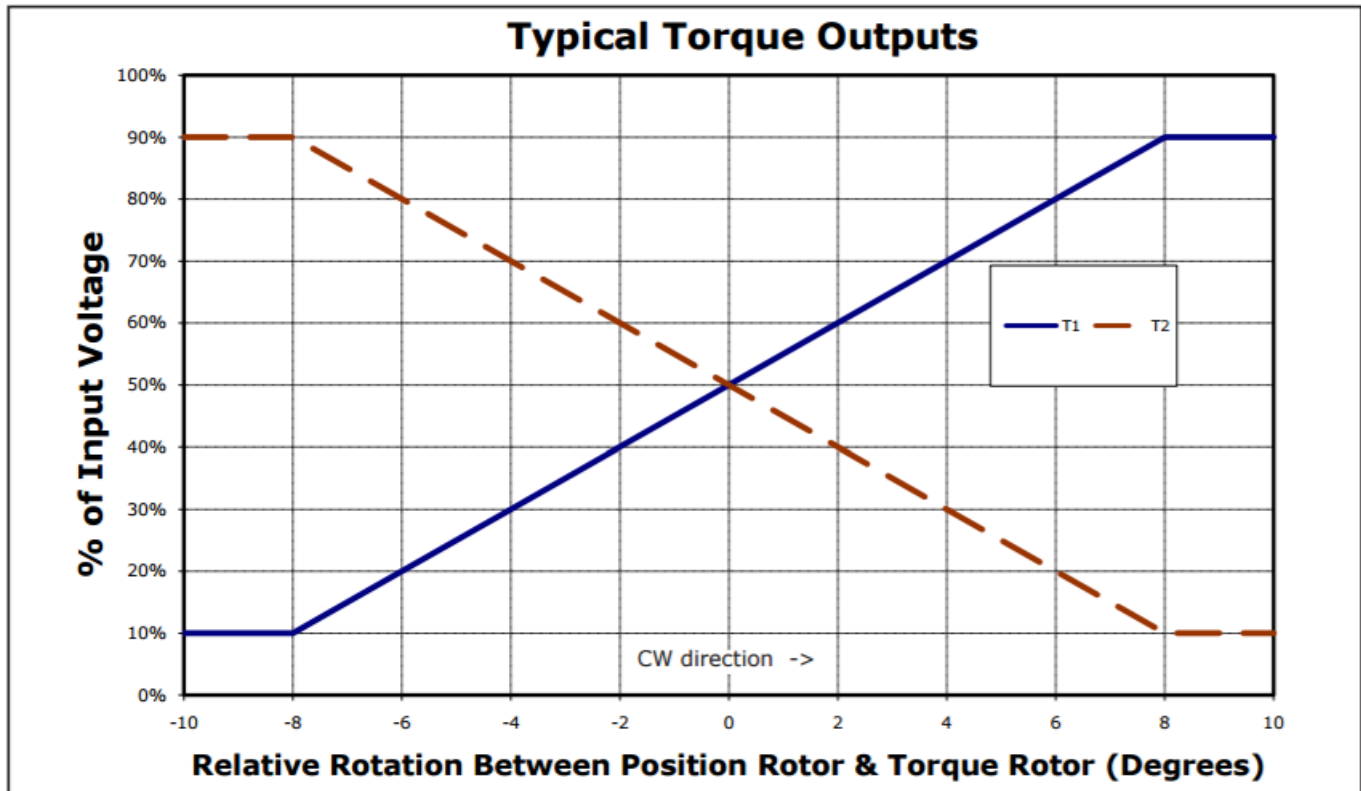
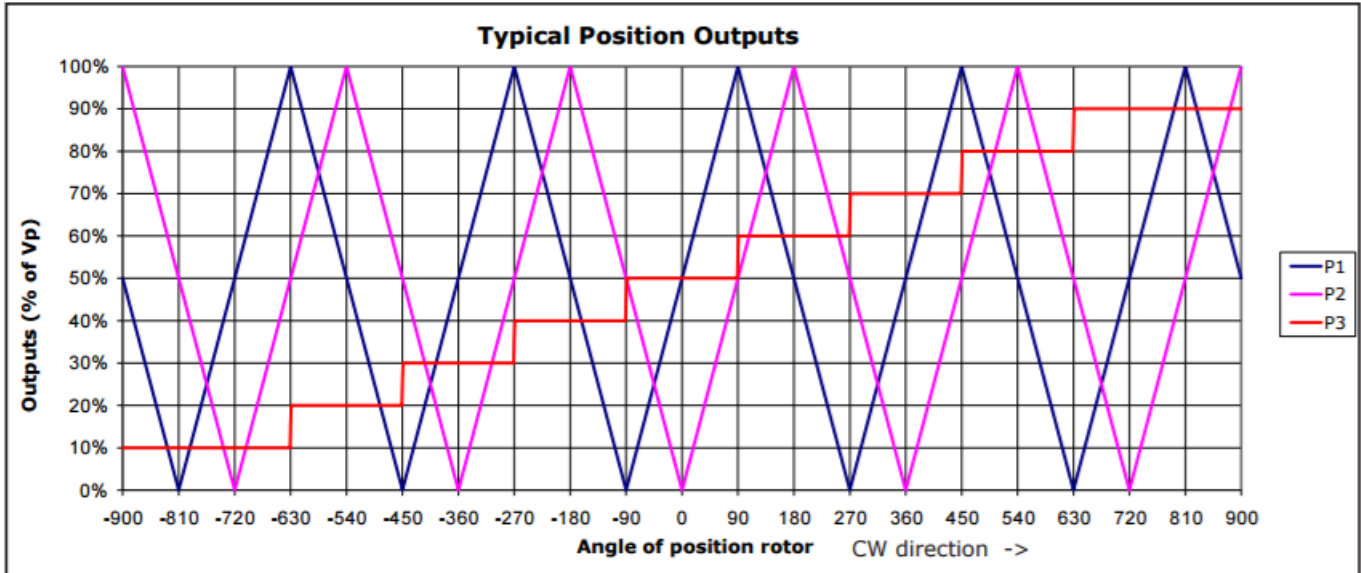

**General Note**

TT Electronics reserves the right to make changes in product specification without notice or liability. All information is subject to TT Electronics' own data and is considered accurate at time of going to print.

TT Electronics | BI Technologies  
 4200 Bonita Place, Fullerton, CA 92835-1053, USA | Ph: +1 714 447 2300  
[www.ttelectronics.com](http://www.ttelectronics.com) | [sensors@ttelectronics.com](mailto:sensors@ttelectronics.com)

# LH3 Torque & Multi-turn Position Sensor



## Outline Drawing

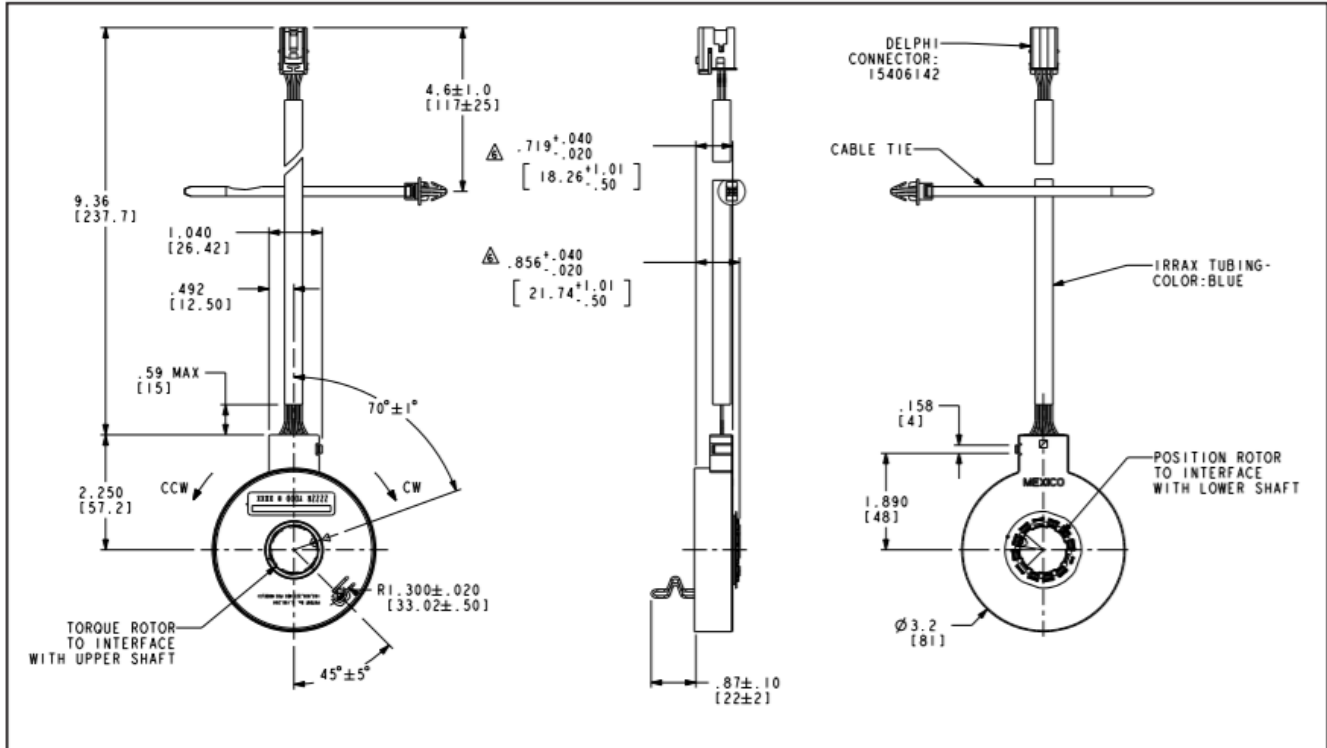

Tolerances ±0.25 mm unless otherwise specified. See drawing # 122-4300-80 for details.

## Pinouts

PIN OUTS-8 PIN CONNECTOR			
DELPHI 15406142			
1	2	3	4
5	6	7	8

(PIN No.'S ARE INDICATED AS WIRES ENTER CONNECTOR END)

PIN No.	SIGNAL	WIRE COLOR
1	P3	YELLOW
2	P1	BROWN
3	Vcc	RED
4	T2	PURPLE
5	NOT USED	- - -
6	P2	WHITE
7	GND	BLACK
8	T1	BLUE

## Barcode Label

**Code 128 symbology**

**4300 A Y DDD T SSSS**

Model #

BI revision letter

Last digit of year

Day of year

Tester #

Sequential serial #

### General Note

TT Electronics reserves the right to make changes in product specification without notice or liability. All information is subject to TT Electronics' own data and is considered accurate at time of going to print.

TT Electronics | BI Technologies  
4200 Bonita Place, Fullerton, CA 92835-1053, USA | Ph: +1 714 447 2300  
www.ttelectronics.com | sensors@ttelectronics.com

## Recommended Interface

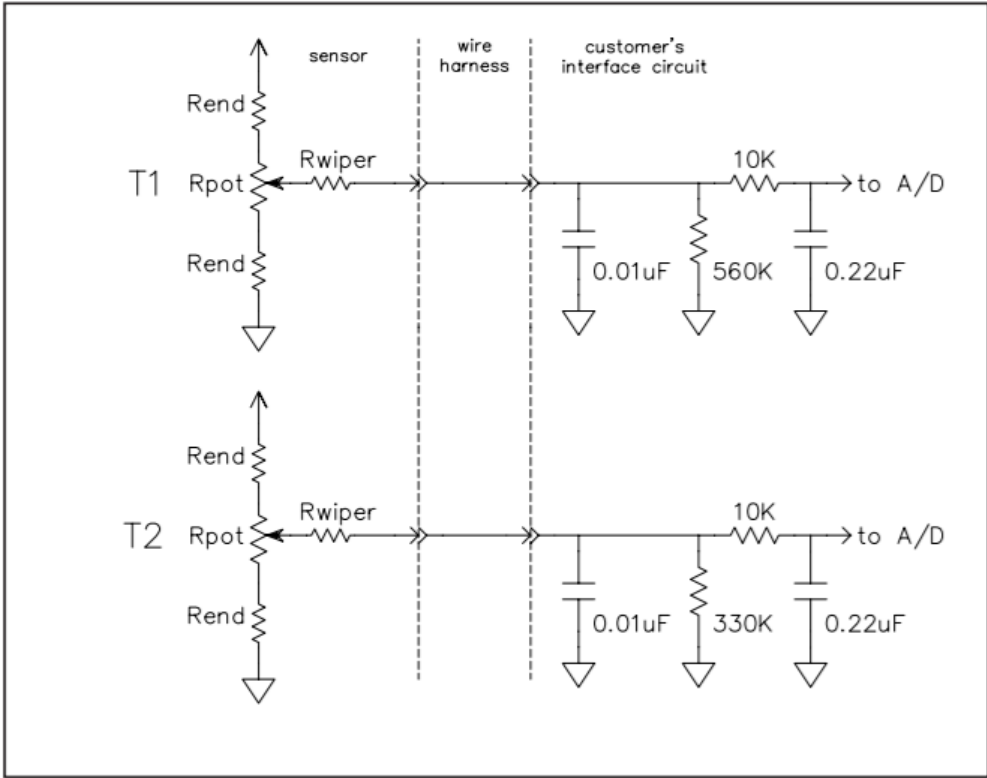
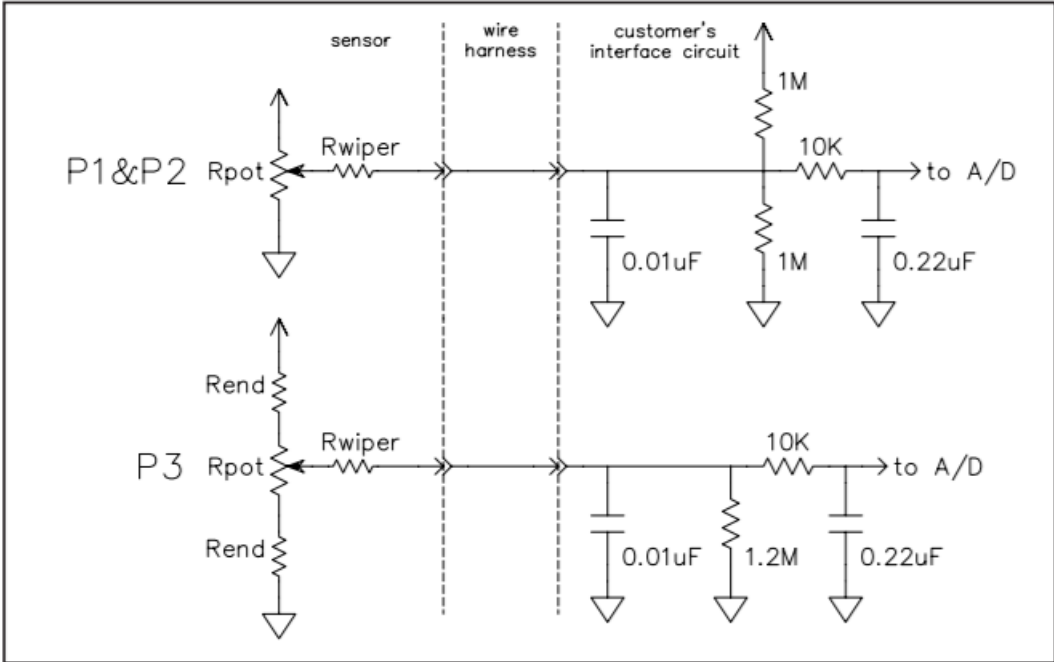

General Note  
 TT Electronics reserves the right to make changes in product specification without notice or liability. All information is subject to TT Electronics' own data and is considered accurate at time of going to print.