

Key Features

- 3W Output at 10% THD with a 4Ω Load and 5V Power Supply
- Filterless, Low Quiescent Current and Low EMI
- Low THD+N
- Power Limit Function to Protect Speaker when Occuring large Input, ±5% Power limit Accuracy
- 64-step DC Volume Control from -45dB to 24dB
- Headphone Output Function
- 12dB Effective Noise Reduction
- Superior Low Noise: 30uV
- Minimize Pop/Clip Noise
- High Efficiency up to 90%
- Auto Recovery Short Circuit Protection
- Thermal Shutdown
- Pb-Free Package

Applications

- LCD Monitors / TV Projectors
- Notebook/All-in-one Computers
- Portable Speakers
- Portable DVD Players, Game Machines

General Description

The PAM8010 is a 3W, class-D audio amplifier with headphone amplifier. Advanced 64-step DC volume control minimizes external components and allows speaker volume control and headphone volume control.

Integrated power limit technology which suppress the output signal clip automatically due to the over level input signal. It offers low THD+N, to produce high-quality sound reproduction.

PAM8010 has an additional noise reduction circuit which achieve 12dB noise attenuation. This circuit may help eliminate external filtering, thereby saving the board space and components cost.

The PAM8010 features SCP (short circuit protection), OTP and thermal shutdown.

The PAM8010 is available in SSOP-24 and SOP-24 package.

Typical Application

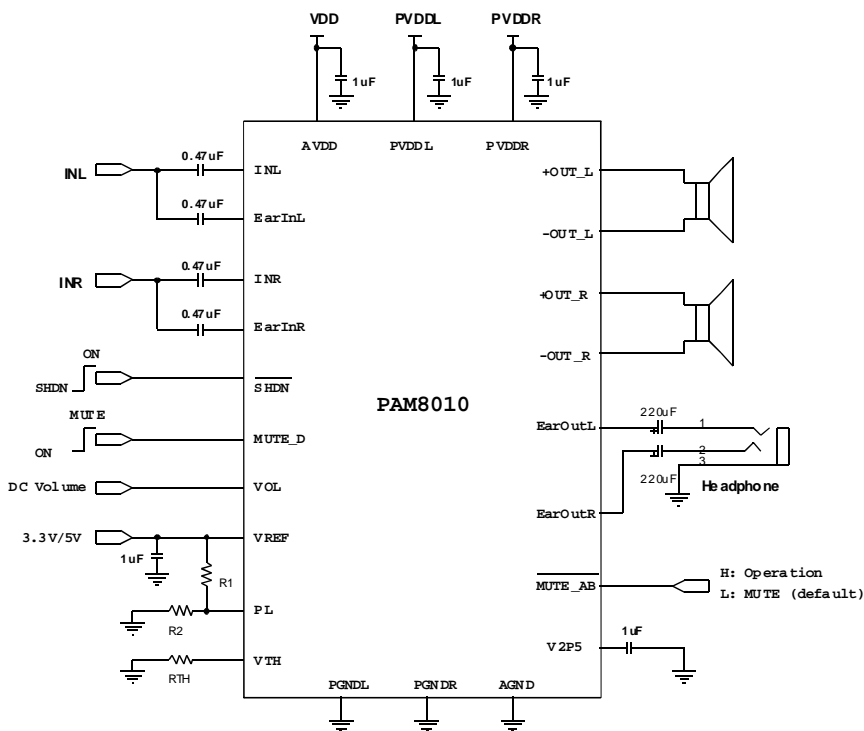

Block Diagram

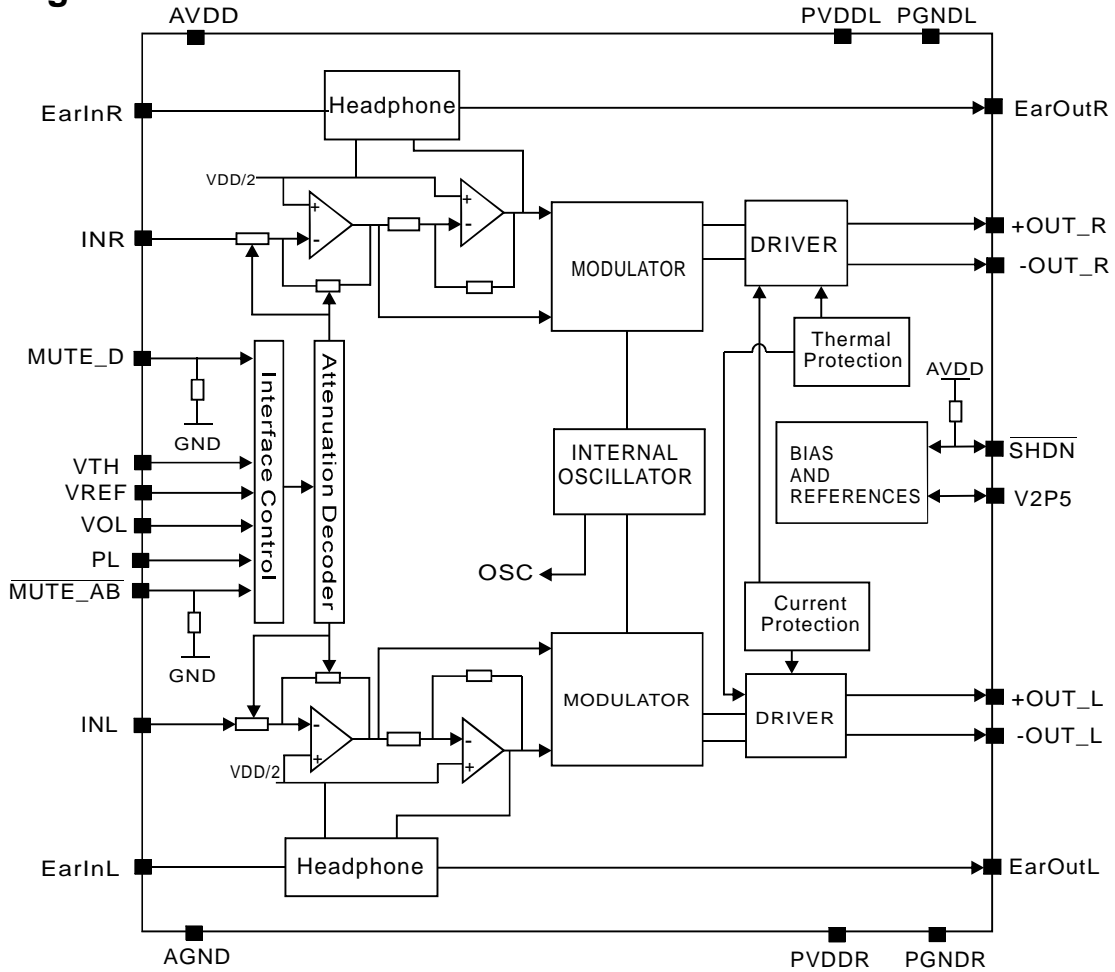

Pin Configuration & Marking Information

SSOP24/SOP24
Top View

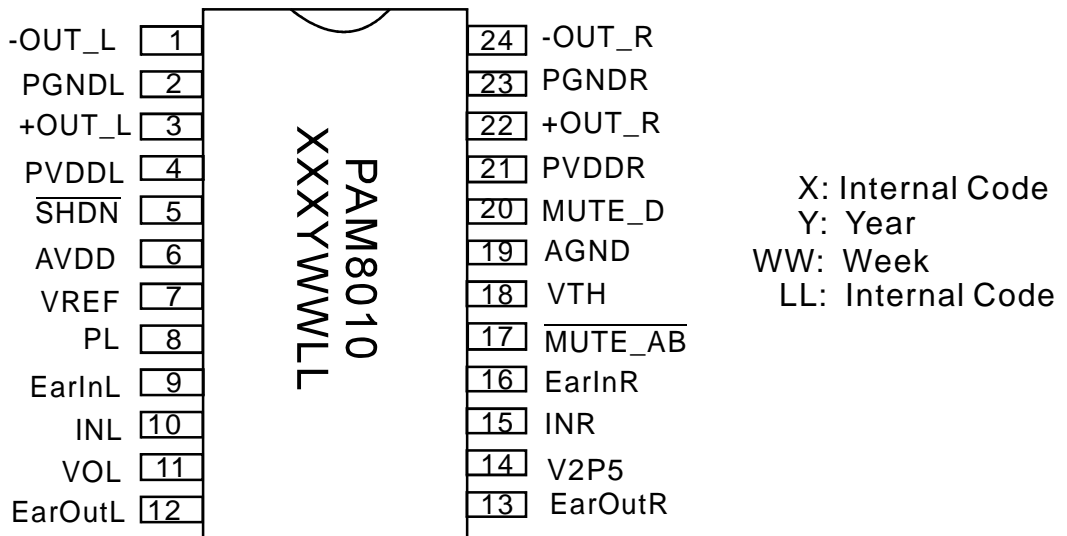



Pin Descriptions

Pin Number	Pin Name	Description
1	-OUT_L	Left Channel Negative Output
2	PGNDL	Left Channel Power GND
3	+OUT_L	Left Channel Positive Output
4	PVDDL	Left Channel Power Supply
5	$\overline{\text{SHDN}}$	Full Chip Shutdown Control Input(active low), Pull-up
6	AVDD	Analog VDD
7	VREF	Reference Voltage Both for DC Volume Control and Power Limit Section
8	PL	Connect a Resistor Divider from VREF to GND for Power Limit Setting
9	EarInL	Left Earphone input
10	INL	Left Channel Input
11	VOL	Apply DC Voltage at This Pin to Set The Gain both of Class D and Class AB
12	EarOutL	Left Earphone output(Non-Inverting)
13	EarOutR	Right Earphone output(Non-Inverting)
14	V2P5	Internal Analog Reference, Connect a Bypass Capacitor from V2P5 to GND
15	INR	Right Channel Input
16	EarInR	Right Earphone Input
17	$\overline{\text{MUTE_AB}}$	Mute control of Class AB Section (active low), Pull-up
18	VTH	Connect a Resistor from VTH to GND for Noise Threshold Setting
19	AGND	Analog GND
20	MUTE_D	Mute Control of Class D Section (active high), Pull-down
21	PVDDR	Right Channel Power Supply
22	+OUT_R	Right Channel Positive Output
23	PGNDR	Right Channel Power GND
24	-OUT_R	Right Channel Negative Output

Absolute Maximum Ratings

These are stress ratings only and functional operation is not implied. Exposure to absolute maximum ratings for prolonged time periods may affect device reliability. All voltages are with respect to ground.

Supply Voltage	6.0V	Operation Junction Temperature	-40°C to 125°C
Input Voltage.....	-0.3V to $V_{DD}+0.3V$	Storage Temperature.....	-65°C to 150°C
		Soldering Temperature.....	300°C,5sec

Recommended Operating Conditions

Supply Voltage Range.....	2.5V to 5.5V	Ambient Operation Temperature	
Junction Temperature Rang.....	-20°C to 125°C	Range.....	-20°C to 85°C

Thermal Information

Parameter	Symbol	Package	Maximum	Unit
Thermal Resistance (Junction to Ambient)	θ_{JA}	SSOP-24	96	°C/W
Thermal Resistance (Junction to Ambient)	θ_{JA}	SOP-24	79.2	°C/W



Electrical Characteristic

$V_{DD}=5V$, Gain = Maximum, $R_L=8\Omega$, $T_A=25^\circ C$, unless otherwise noted.

PARAMETER	SYMBOL	CONDITIONS	MIN	TYP	MAX	UNITS
Class D Stage						
Supply Voltage Range	V_{DD}		2.5		5.5	V
Quiescent Current	I_Q	No Load		10	15	mA
Output Offset Voltage	V_{OS}	No Load			30	mV
Drain-Source On-State Resistance	$R_{DS(ON)}$	$I_{DS}=0.5A$	P MOSFET	0.21		Ω
			N MOSFET	0.17		
Output Power	P_O	THD+N=10%, $f=1kHz$	$R_L=8\Omega$	1.55	1.7	W
			$R_L=4\Omega$	2.85	3.0	
Total Harmonic Distortion Plus Noise	THD+N	$R_L=8\Omega, P_O=0.85W, f=1kHz$		0.08		%
		$R_L=4\Omega, P_O=1.75W, f=1kHz$		0.08		
Power Supply Ripple Rejection	PSRR	Input AC-GND, $f=1kHz, V_{pp}=200mV$		70		dB
Channel Separation	CS	$P_O=1W, f=1kHz$		-95		dB
Oscillator Frequency	f_{osc}		200	250	300	kHz
Efficiency	η	$P_O=1.7W, f=1kHz, R_L=8\Omega$		85	90	%
		$P_O=3.0W, f=1kHz, R_L=4\Omega$		80	83	
Noise	V_n	Input AC-GND	A-weighting	60		μV
			No A-weighting	80		
Signal Noise Ratio	SNR	$f=20-20kHz, THD=1\%$		95		dB
Earphone Stage						
Output Offset Voltage	V_{OS}	No Load	2.45	2.5	2.55	V
Output Power	P_O	THD+N=1%, $R_L=32\Omega, f=1kHz$		60		mW
Total Harmonic Distortion Plus Noise	THD+N	$R_L=32\Omega, P_O=10mW, f=1kHz$		0.02		%
Power Supply Ripple Rejection	PSRR	Input AC-GND, $f=1kHz, V_{pp}=200mV$		80		dB
Channel Separation	CS	$V_O=1V, f=1kHz$		-95		dB
Noise	V_n	Input AC-GND	A-weighting	20		μV
			No A-weighting	35		
Signal Noise Ratio	SNR	$f=20-20kHz, THD=1\%$		95		dB
Control Section						
Mute Current	I_{MUTE}	MUTE_D=VDD, MUTE_AB=GND		7	10	mA
Mute Class D Earphone Current	I_{MUTE_D}	MUTE_D=VDD, MUTE_AB=VDD		7	10	mA
Mute Class AB Earphone Current	I_{MUTE_AB}	MUTE_D=GND, MUTE_AB=VDD		9	10	mA
Shutdown Current	I_{SHDN}	$V_{SHDN}=0V$			1	μA
Logic Input High	V_{IH}		1.4			V
Logic Input Low	V_{IL}				0.6	
Over Temperature Protection	OTP			150		$^\circ C$
Over Temperature Hysteresis	OTH			40		$^\circ C$

Typical Operating Characteristics ($T_A=25^\circ\text{C}$)

$V_{DD}=5\text{V}$, $R_L=8\Omega$, $G_v=24\text{dB}$, $T_A=25^\circ\text{C}$, unless otherwise noted

Class D Output

1. THD+N vs Output Power

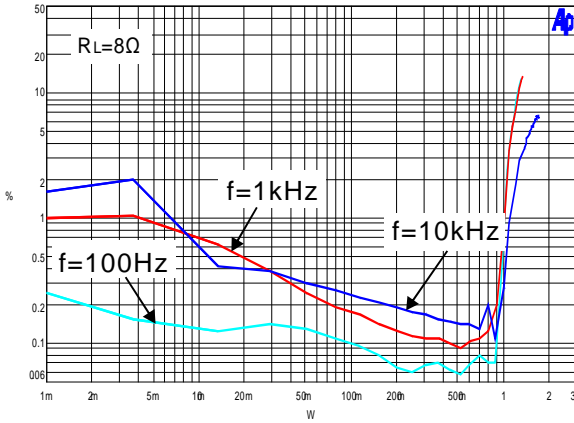

2. THD+N vs Output Power

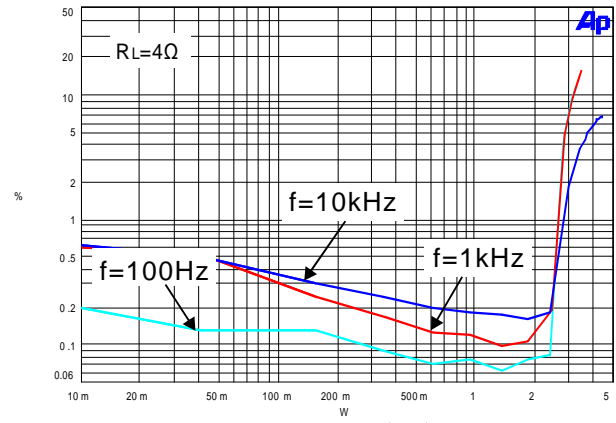

3. THD+N vs Frequency

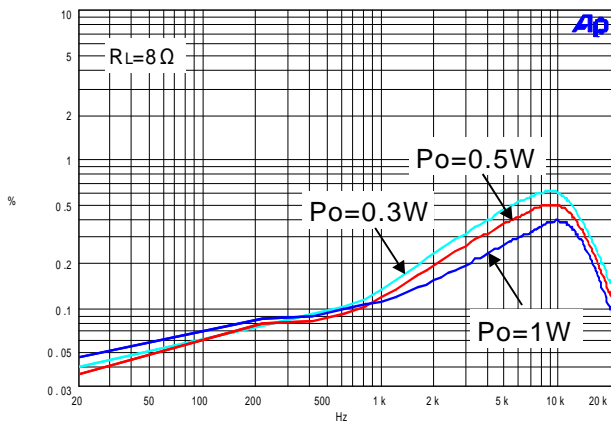

4. THD+N vs Frequency

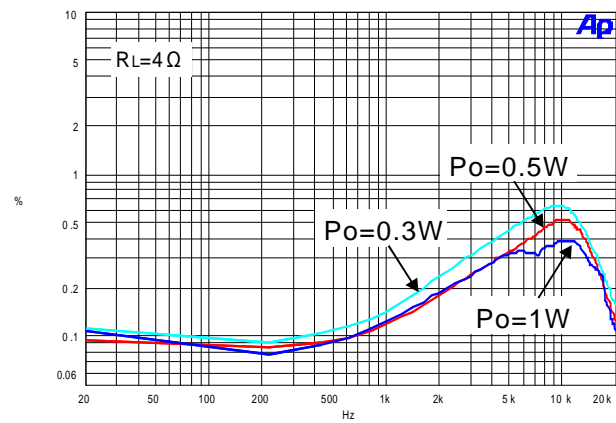

5. PSRR vs Frequency

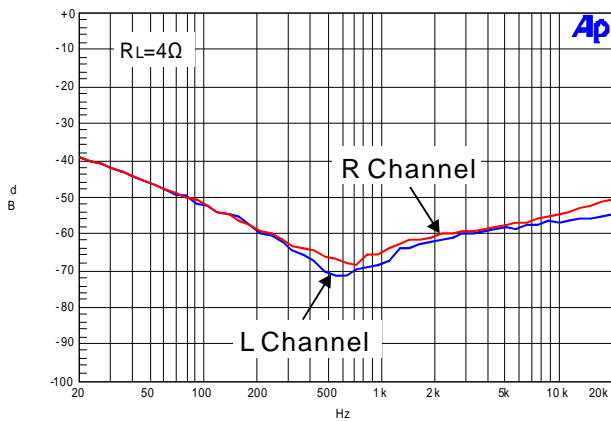

6. Crosstalk vs Frequency

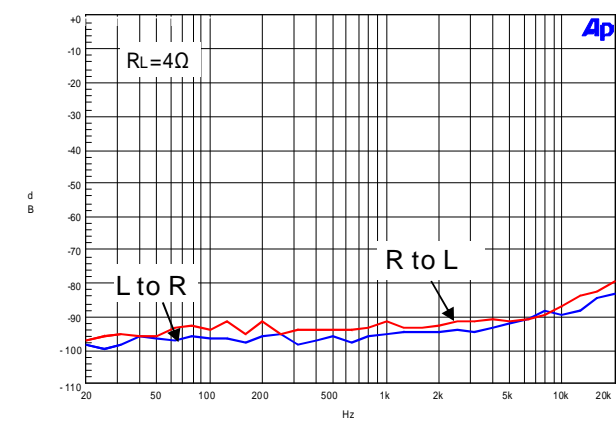

Typical Operating Characteristics ($T_A=25^\circ\text{C}$)

$V_{DD}=5\text{V}$, $R_L=8\Omega$, $G_v=24\text{dB}$, $T_A=25^\circ\text{C}$, unless otherwise noted

Class D Output

7. Frequency Response

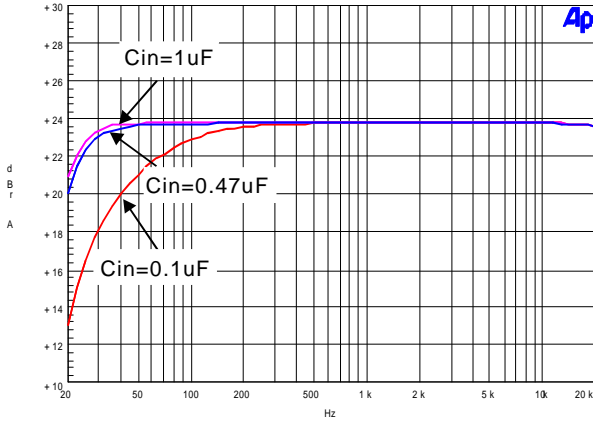

8. Noise Floor

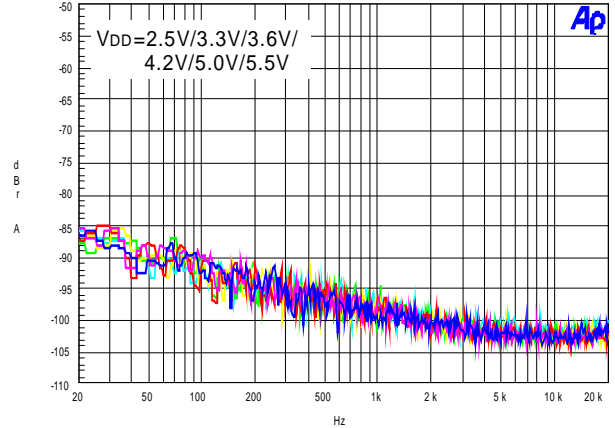

9. Power Dissipation vs Output Power

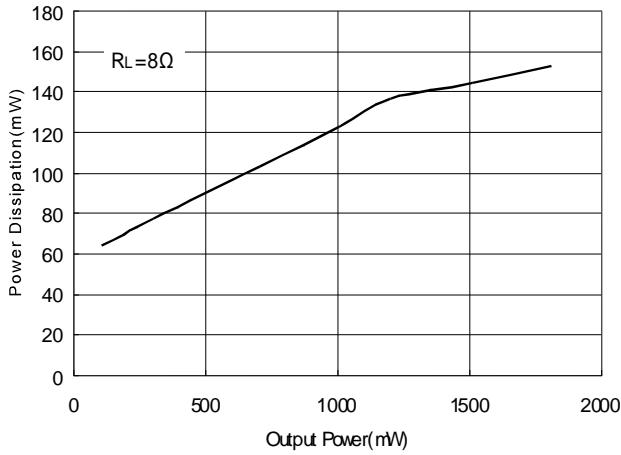

10. Power Dissipation vs Output Power

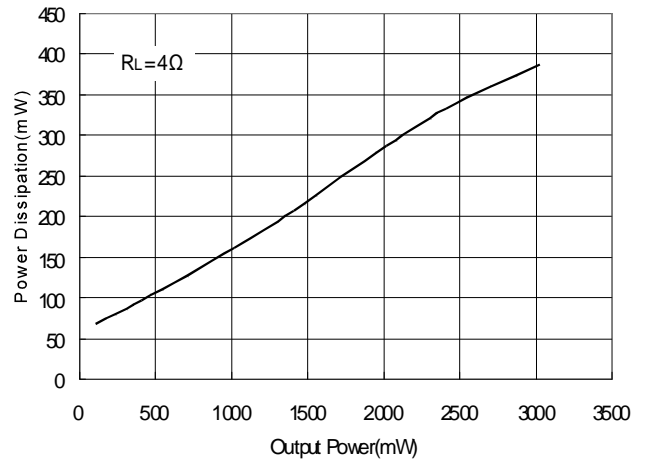

11. Efficiency VS Output Power

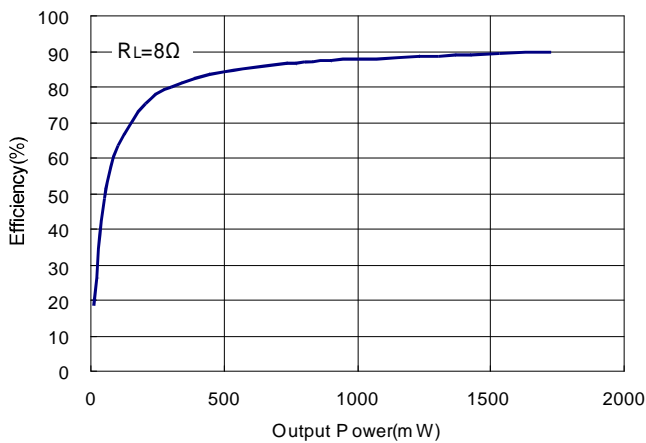

12. Efficiency VS Output Power

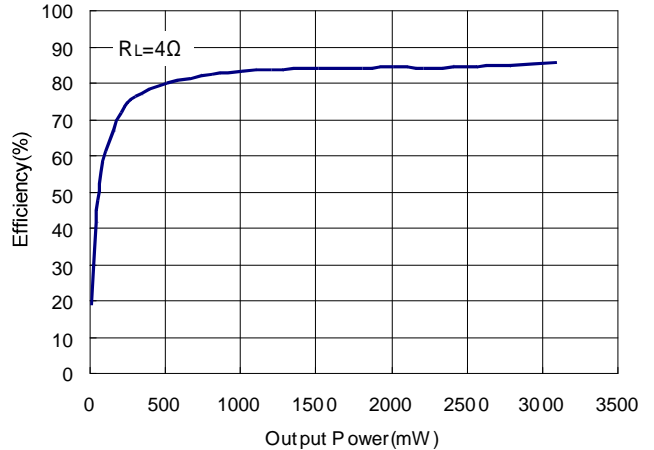

Typical Operating Characteristics (continued)

13. Output Power VS Supply Voltage

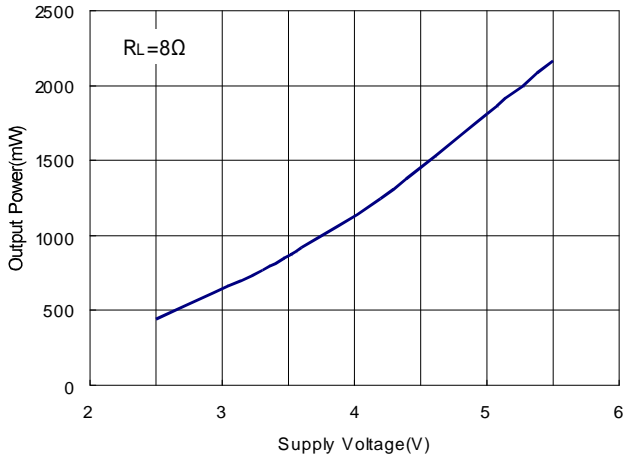

14. Output Power VS Supply Voltage

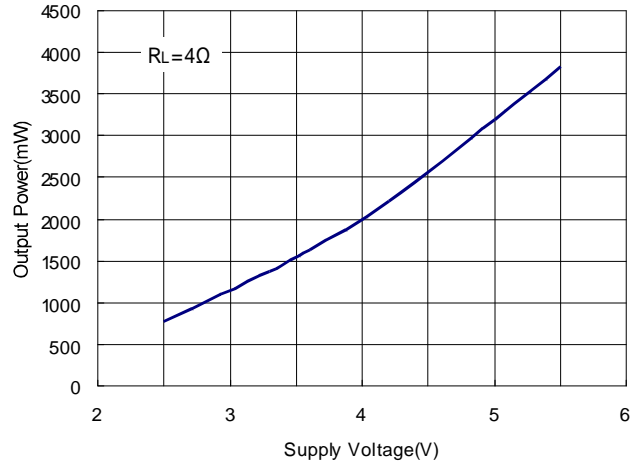

15. Rdson VS Output Current

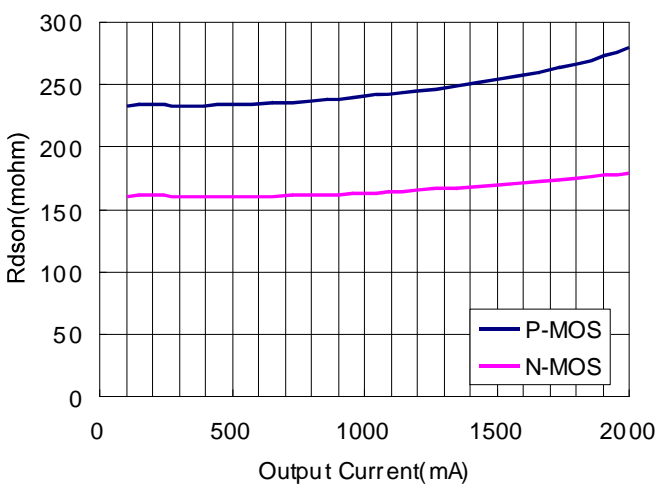

16. Switching Frequency VS Supply Voltage

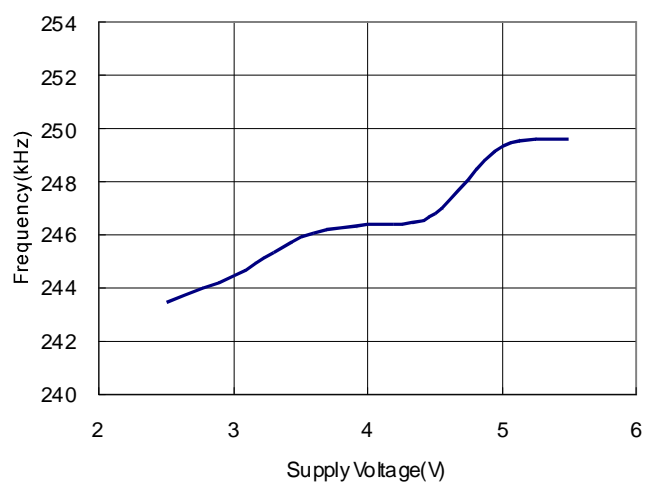

17. Quiescent Current



18. Gain Step

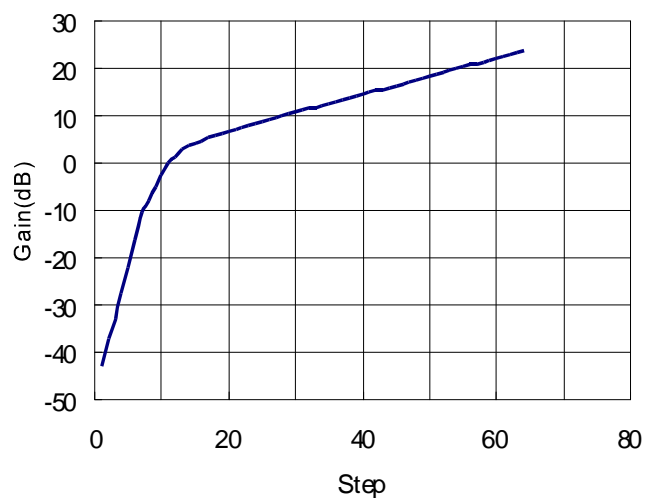

Typical Operating Characteristics (continued)

19. Output Power VS PL-Voltage

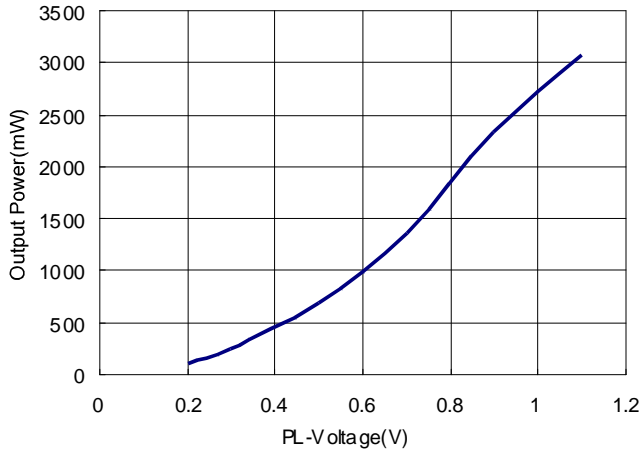

20. Noise Threshold VS RTH

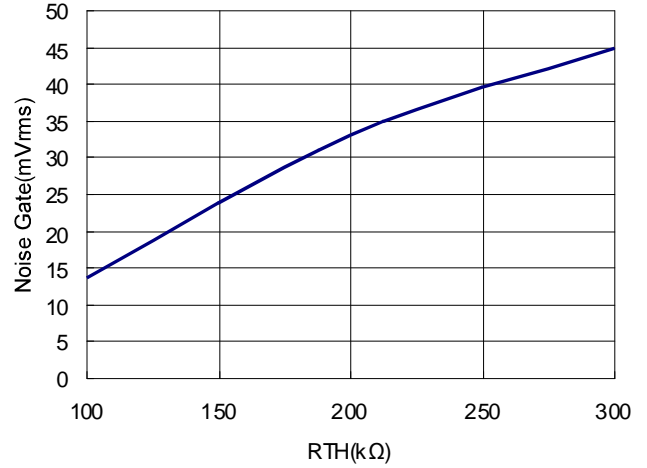

Typical Operating Characteristics (continued)

$V_{DD}=5V, G_v=10dB, T_A=25^\circ C$, unless otherwise noted

Earphone Output

1. THD+N vs Output Power

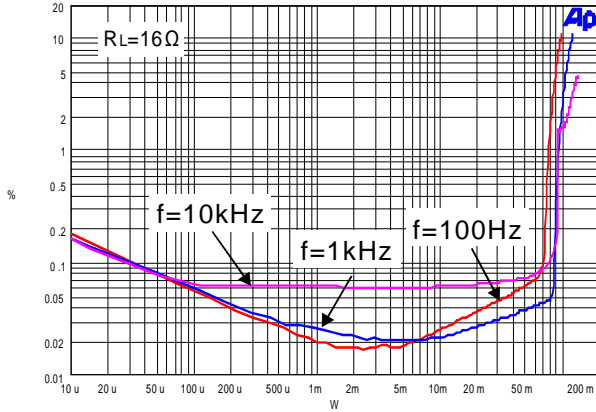

2. THD+N vs Output Power

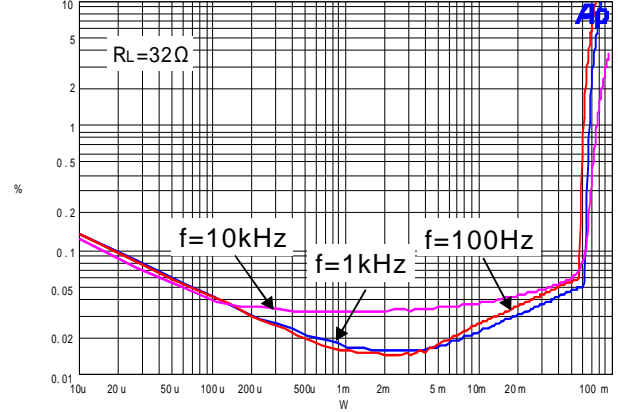

3. THD+N vs Frequency

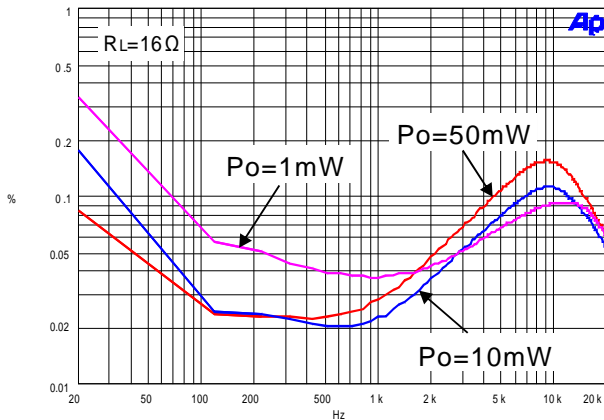

4. THD+N vs Frequency

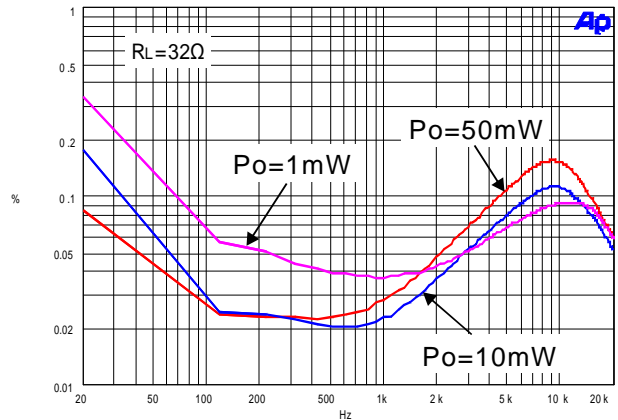

5. PSRR vs Frequency

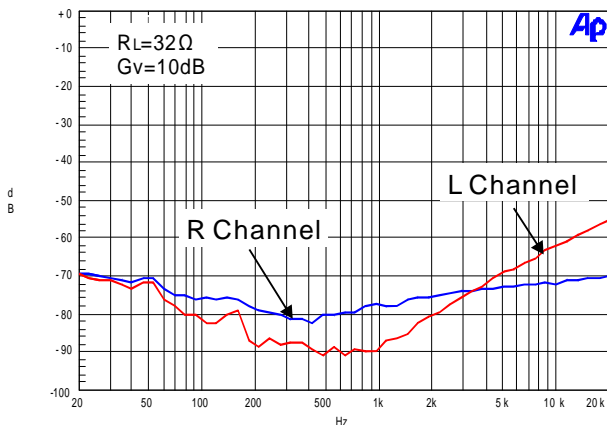

6. Crosstalk vs Frequency

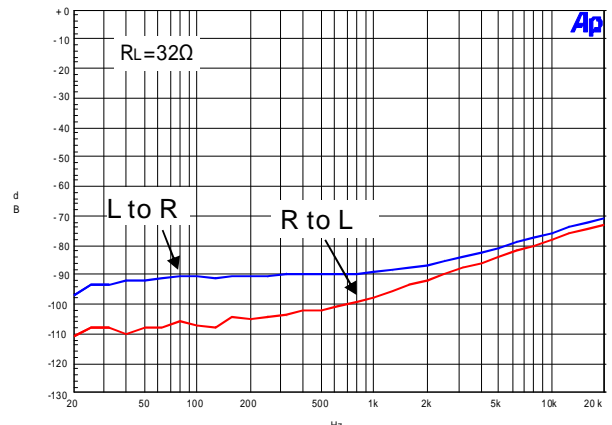

Typical Operating Characteristics (continued)

7. Frequency Response

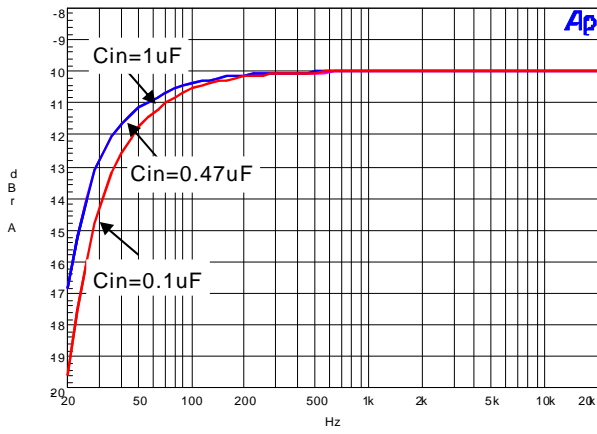

8. Noise Floor

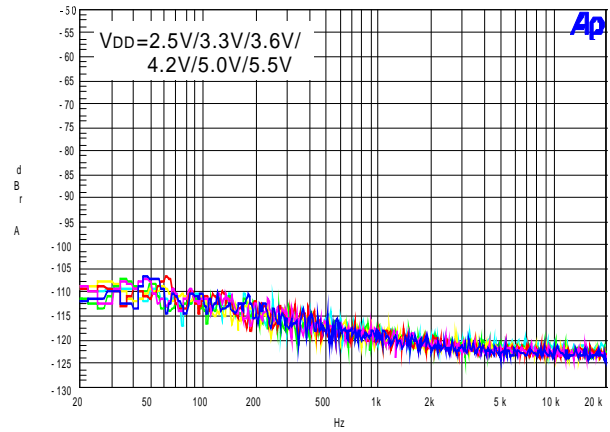

9. Gain Step

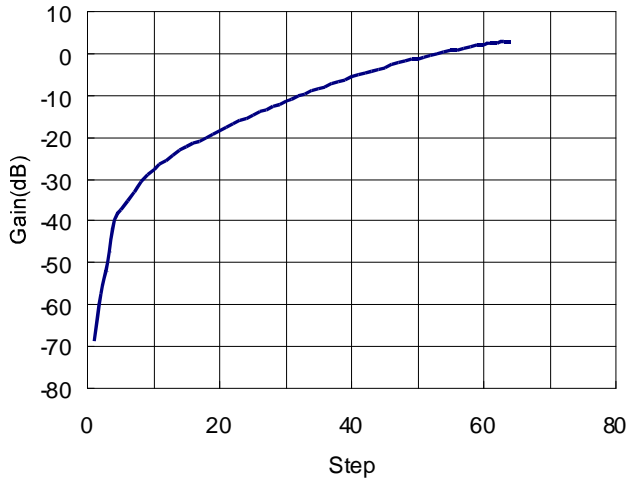



Typical Operating Characteristics (continued)

Table 1. DC Volume Control

STEP	Gain(dB) Class D	Gain(dB) Earphone	STEP	Gain(dB) Class D	Gain(dB) Earphone
1	-43.1	-68.5	33	11.9	-9.6
2	-37.2	-57.4	34	12.2	-9
3	-34.3	-49.7	35	12.7	-8.5
4	-27.7	-39.8	36	13	-7.9
5	-22.1	-37.4	37	13.4	-7.3
6	-16.3	-35.2	38	13.8	-6.7
7	-10.3	-33.1	39	14.2	-6.2
8	-7.8	-30.8	40	14.6	-5.7
9	-5.2	-28.7	41	15	-5.2
10	-2.7	-27.7	42	15.4	-4.7
11	0.2	-26.6	43	15.5	-4.2
12	1.3	-25.5	44	15.8	-3.7
13	2.8	-24.3	45	16.2	-3.2
14	3.8	-23.2	46	16.6	-2.7
15	4.2	-22.4	47	17	-2.3
16	4.6	-21.6	48	17.4	-1.9
17	5.4	-20.8	49	17.8	-1.5
18	5.8	-20	50	18.2	-1.1
19	6.2	-19.2	51	18.6	-0.7
20	6.6	-18.4	52	19	-0.32
21	7	-17.6	53	19.4	0.09
22	7.4	-16.7	54	19.8	0.4
23	7.8	-16.1	55	20.2	0.7
24	8.2	-15.4	56	20.6	0.97
25	8.6	-14.7	57	21	1.3
26	9	-14.1	58	21.4	1.6
27	9.4	-13.4	59	21.9	1.9
28	9.8	-12.7	60	22.2	2.2
29	10.3	-12.1	61	22.6	2.35
30	10.5	-11.4	62	23.1	2.6
31	11	-10.8	63	23.5	2.8
32	11.5	-10.2	64	23.9	3

Test Setup for Performance Testing(Class D)

Application Notice

1. When the PAM8010 works with LC filters, it should be connected with the speaker before it's powered on, otherwise it will be damaged easily.
2. When the PAM8010 works without LC filters, it's better to add a ferrite chip bead at the outgoing line of speaker for suppressing the possible electromagnetic interference.
3. The absolute maximum rating of the PAM8010 operation voltage is 6.0V. When the PAM8010 is powered with 4 battery cells, it should be noted that the voltage of 4 new dry or alkaline batteries is over 6V, higher than its maximum operation voltage, which probably

make the device damaged. Therefore, it's recommended to use either 4 Ni-MH (Nickel Metal Hydride) rechargeable batteries or 3 dry or alkaline batteries.

4. The input signal should not be too high, if too high, it will cause the clipping of output signal when increasing the volume. Because the DC volume control of the PAM8010 has big gain, it will make the device damaged.

5. When testing the PAM8010 without LC filters by using resistor instead of speaker as the output load, the test results, e.g. THD or efficiency, will be worse than those using speaker as load.

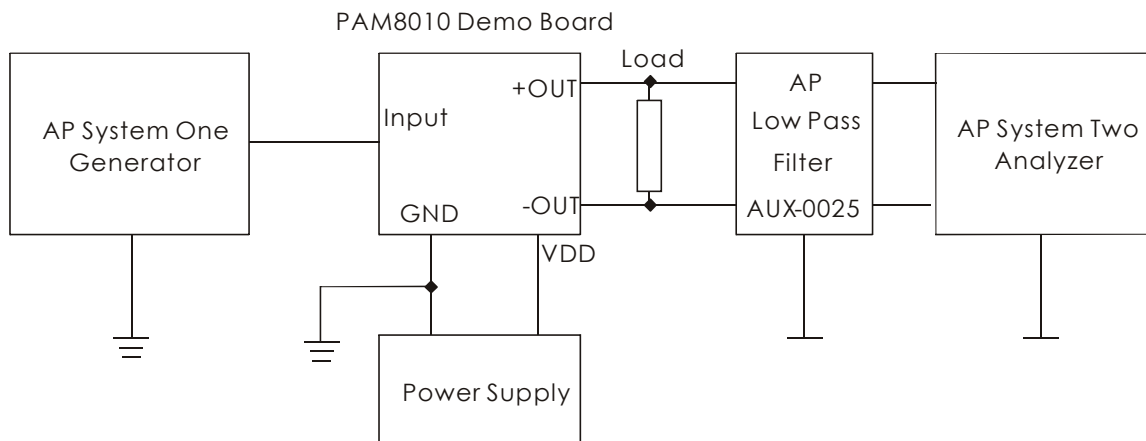

Notes

1. The AP AUX-0025 low pass filter is necessary for class-D amplifier measurement with AP analyzer.
2. Two 22 μ H inductors are used in series with load resistor to emulate the small speaker for efficiency measurement.



Application Information(continued)

Power Limit Function

The maximum output power of Class D section is set by applying a DC voltage at PL pin. Add a resistor divider from AVDD (Pin 6) to ground to set the voltage at the PL pin. An external reference may also be used at VREF (Pin7) if tighter tolerance is required. Also add a 1uF capacitor from pin7 to ground(see the application circuit on page 1).

Different from other company's power limit, the power limit circuit of PAM8010 sets a limit on the output peak voltage, and the value is lower than the half supply voltage(PVDD) makes the PAM8010 never clipping, it means the THD+N always lower than 1% when power limit works.

Noise Reduction Function

The gain of PAM8010 will reduce 12dB when there is no audio at the input of the amplifier for 8s. The gain will recovered until the input signal is above the noise threshold which is set at VTH(Pin18), and the noise threshold is set by an external resistor from VTH to ground.

Mute Operation

The MUTE_D pin is an input for controlling the Class D output state of the PAM8010. A logic low on this pin enables the outputs, and a logic high on this pin disables the outputs. This pin may be used as a quick disable or enable of the outputs without a volume fade. Quiescent current is listed in the electrical characteristic table. The MUTE_D pin can be left floating due to the internal pull-down.

The MUTE_AB pin is an input for controlling the Class AB output state of the PAM8010. A logic high on this pin enables the outputs, and a logic low on this pin disables the outputs.

Shutdown operation

In order to reduce power consumption while not in use, the PAM8010 contains shutdown circuitry to turn off the amplifier's bias circuitry. The amplifier is turned off when logic low is placed on the SHDN pin. By switching the SHDN pin connected to GND, the PAM8010 supply current draw will be minimized in idle mode. The SHDN pin can be left floating due to the internal pull-up.

For the best power on/off pop performance, the amplifier should be placed in the Mute mode prior to turning on/off the power supply.

Power supply decoupling

The PAM8010 is a high performance CMOS audio amplifier that requires adequate power supply decoupling to ensure the output THD and PSRR are as low as possible. Power supply decoupling affects low frequency on the power supply leads. For higher frequency response. Optimum decoupling is achieved by using two capacitors of different types that target different types of noise frequency transients, spikes, or digital hash on the line, a good low equivalent-series-resistance (ESR) ceramic capacitor, typically 1.0μF, placed as close as possible to the device V_{DD} terminal works best. For filtering lower-frequency noise signals, a large capacitor of 10μF(ceramic) or greater placed near the audio power amplifier is recommended.

Input Capacitor (C_i)

Large input capacitors are both expensive and space hungry for portable designs. Clearly, a certain sized capacitor is needed to couple in low frequencies without severe attenuation. But in many cases the speakers used in portable systems, whether internal or external, have little ability to reproduce signals below 100Hz to 150Hz. Thus, using a large input capacitor may not increase actual system performance. In this case, input capacitor (C_i) and input resistance (R_i) of the amplifier form a high-pass filter with the corner frequency determined equation below,

$$f_c = \frac{1}{2\pi R_i C_i}$$

In addition to system cost and size, click and pop performance is affected by the size of the input coupling capacitor, C_i. A larger input coupling capacitor requires more charge to reach its quiescent DC voltage (nominally 1/2 V_{DD}). This charge comes from the internal circuit via the feedback and is apt to create pops upon device enable. Thus, by minimizing the capacitor size based on necessary low frequency response, turn-on pops can be minimized.

Analog Reference Bypass Capacitor (C_{BYP})

The Analog Reference Bypass Capacitor (C_{BYP}) is the most critical capacitor and serves several important functions. During start-up or recovery from shutdown mode, C_{BYP} determines the rate at which the amplifier starts up. The second function is to reduce noise produced by the power supply caused by coupling into the output drive signal.

Application Information(continued)

Over Temperature Protection

Thermal protection on the PAM8010 prevents the device from damage when the internal die temperature exceeds 150°C. There is a 15 degree tolerance on this trip point from device to device. Once the die temperature exceeds the thermal set point, the device outputs are disabled. This is not a latched fault. The thermal fault is cleared once the temperature of the die is reduced by 40°C. This large hysteresis will prevent motor boating sound well. The device begins normal operation at this point without external system interaction. Before thermal shutdown, the gain of the PAM8010 will drop -3dB when the chip temperature reaches 120°C.

How to Reduce EMI (Electro Magnetic Interference)

A simple solution is to put an additional capacitor 1000uF at power supply terminal for power line coupling if the traces from amplifier to speakers are short (<20CM).

Most applications require a ferrite bead filter as shown at Figure 1. The ferrite filter reduces EMI around 1 MHz and higher. When selecting a ferrite bead, choose one with high impedance at high frequencies, and low impedance at low frequencies (MH2012HM221-T).

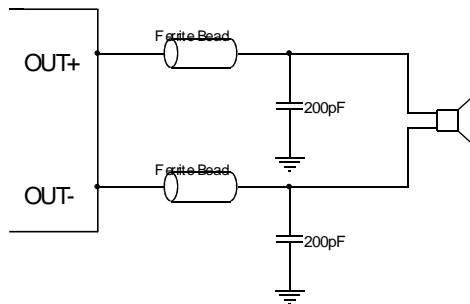

Figure 1: Ferrite Bead Filter to reduce EMI

PCB Layout Guidelines Grounding

At this stage it is paramount to notice the necessity of separate grounds. Noise currents in the output power stage need to be returned to output noise ground and nowhere else. Were these currents to circulate elsewhere, they may get into the power supply, the signal ground, etc, worse yet, they may form a loop and radiate noise. Any of these cases results in degraded amplifier performance. The logical returns for the output noise currents associated with Class D switching are the respective PGND pins for each

channel. The switch state diagram illustrates that PGND is instrumental in nearly every switch state. This is the perfect point to which the output noise ground trace should return. Also note that output noise ground is channel specific. A two channel amplifier has two separate channels and consequently must have two separate output noise ground traces. The layout of the PAM8010 offers separate PGND connections for each channel and in some cases each side of the bridge. Output noise grounds must be tied to system ground at the power in exclusively. Signal currents for the inputs, reference, etc need to be returned to quiet ground. This ground is only tied to the signal components and the GND pin, and GND then tied to system ground.



Ordering Information

PAM8010 X X X

Shipping
Number of Pins
PackageType

Part Number	Package Type	Standard Package
PAM8010NHR	SSOP-24	2,500 Units/Tape & Reel
PAM8010DHR	SOP-24	1,000 Units/Tape & Reel

Outline Dimension

SSOP-24

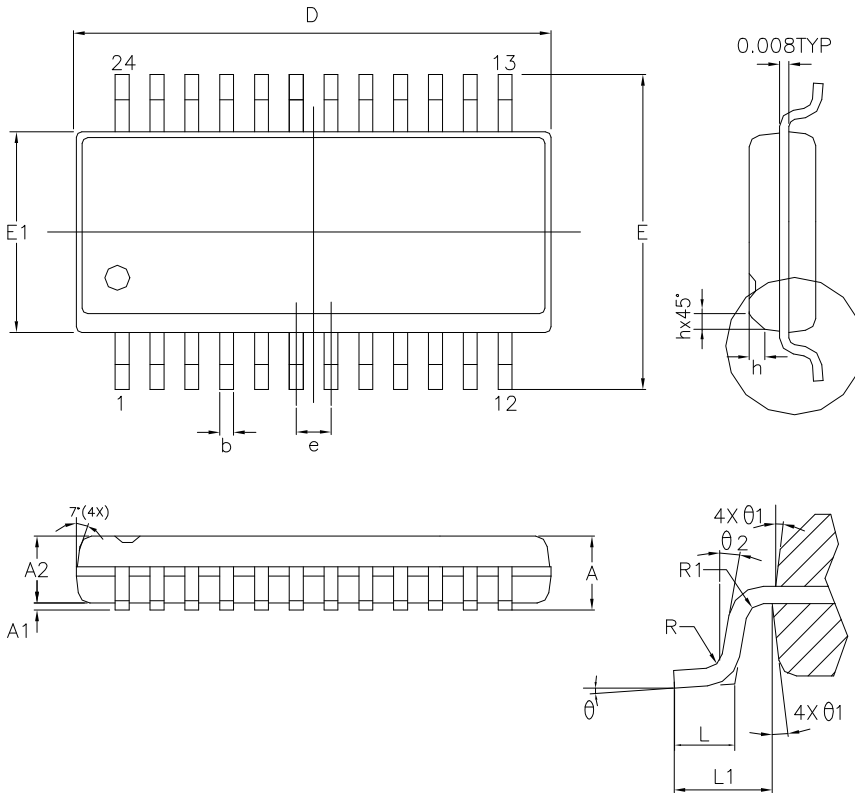

SYMBOLS	MIN.	NOM.	MAX.
A	0.053	0.061	0.069
A1	0.004	—	0.010
A2	0.049	0.057	0.065
b	0.008	0.010	0.012
D	0.335	0.341	0.347
E	0.228	0.236	0.244
E1	0.150	0.154	0.158
e	—	0.025	—
L	0.016	0.033	0.050
L1	0.041 REF		
R	0.003	—	—
R1	0.003	—	—
h	0.010	0.015	0.020
Ø	0°	4°	8°
Ø1	5°	10°	15°
Ø2	0°	—	—

UNIT : INCH

Outline Dimension

SOP-24

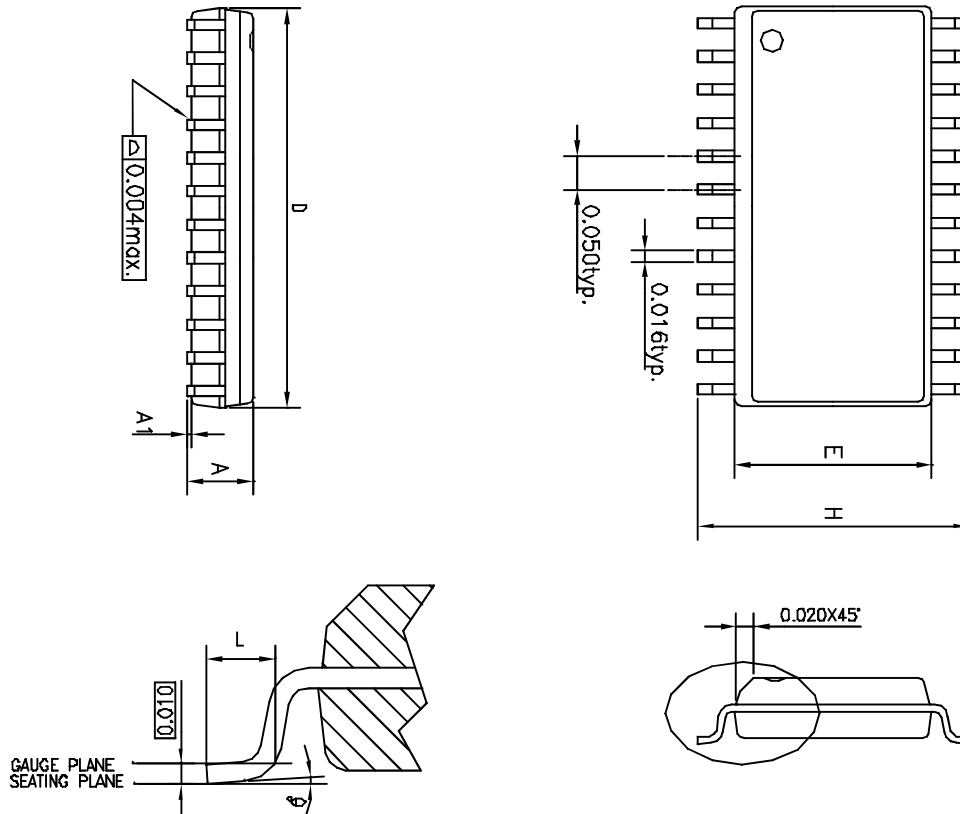

SYMBOLS	MIN.	NOM	MAX.
A	0.093	0.099	0.104
A1	0.004	—	0.012
D	0.599	0.600	0.614
E	0.291	0.295	0.299
H	0.394	0.406	0.419
L	0.016	0.035	0.050
θ°	0	—	8

UNIT : INCH

NOTES:

1. JEDEC OUTLINE : MS-013 AD
2. DIMENSIONS "D" DOES NOT INCLUDE MOLD FLASH, PROTRUSIONS OR GATE BURRS. MOLD FLASH, PROTRUSIONS AND GATE BURRS SHALL NOT EXCEED .15mm (.006in) PER SIDE.
3. DIMENSIONS "E" DOES NOT INCLUDE INTER-LEAD FLASH, OR PROTRUSIONS. INTER-LEAD FLASH AND PROTRUSIONS SHALL NOT EXCEED .25mm (.010in) PER SIDE.