

Si468X EVALUATION BOARD TEST PROCEDURE

1. Introduction

The purpose of this document is to describe the test procedures used in Silicon Laboratories for the Si468x evaluation boards (EVB). It is also intended to enable customers to exactly replicate Silicon Laboratories' test environment so that variances in customers' and Silicon Laboratories' measured results can be accurately compared. This document covers FM, FMHD radio, and DAB/DAB+ radio tests for the Si468x receivers and FM HD demodulators. The pass/fail criteria for each test are provided in the respective data sheets.

The Si468x evaluation boards and software provide a platform to program, test, and operate the Si468x devices. The system consists of two boards: a baseboard and an RF daughter card. The baseboard provides all necessary support functions, including a USB-based programming interface, audio output connection points and an optional external clock input. In addition, the baseboard provides a codec for converting analog audio output to I²S digital output. The RF daughter card contains the receiver and connection points for RF input. Refer to the EVB User's Guides for detailed explanations of the EVB hardware and software. Table 1 summarizes the functionality of each device in the family.

Table 1. Product Family Function

Part Number	General Description	TSIF	Audio Support	FM	FM RDS	HD-AM	HD-FM	DAB DAB+	AM	LW/SW	Decode Only
Si4682	FM/FM RDS HD-FM		✓	✓	✓		✓				
Si4684	FM/FM RDS DAB/DAB+/ 		✓	✓	✓			✓			
Si4688	FM/FM RDS HD-FM/DAB DAB+		✓	✓	✓		✓	✓			
Si4683	AM/HD-AM/FM/ FM RDS/HD-FM		✓	✓	✓	✓	✓		✓		
Si4685	AM/FM/FM RDS/ DAB/DAB+		✓	✓	✓			✓	✓		
Si4689	AM/HD-AM/FM/ FM RDS/HD-FM/ DAB/DAB+		✓	✓	✓	✓	✓	✓	✓		

2. Test Setup and Instrument Settings

This section covers the test setup and instrument settings for testing the Si468x receiver. Figure 1 shows the general setup for Si468x EVB testing. Refer to individual test sections for different receiver modes for any configuration changes.

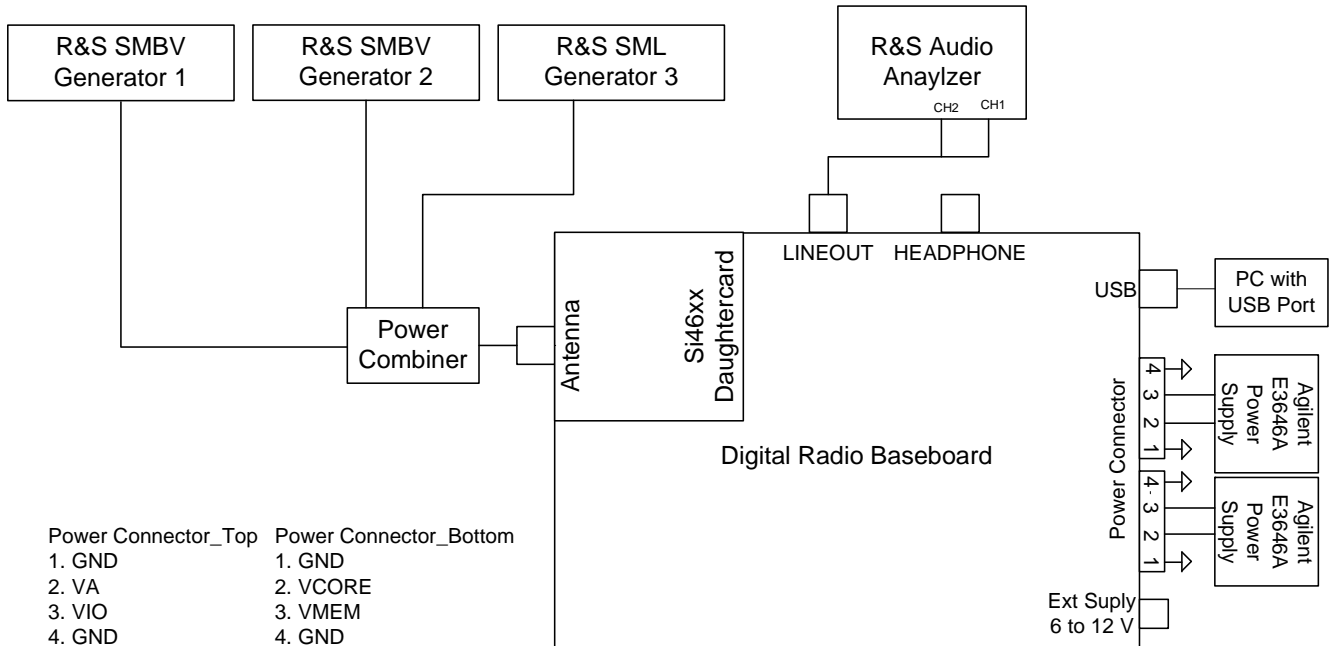

Figure 1. Si468x Test Setup

2.1. Analyzer Configuration

The analyzer is configured in analog mode for the tests. The following configuration is common for all tests:

- Instrument: Analog
- Bandwidth: 22 kHz
- Pre Filter: OFF
- Channel Coupling: AC

2.2. Signal Generator Settings

2.2.1. SMBV Settings for FM Analog, FMHD, DAB, AM Analog, and AMHD Test Cases

Figure 2 shows the SMBV front panel after an instrument preset. From this panel, you can setup the generator for the following test cases.

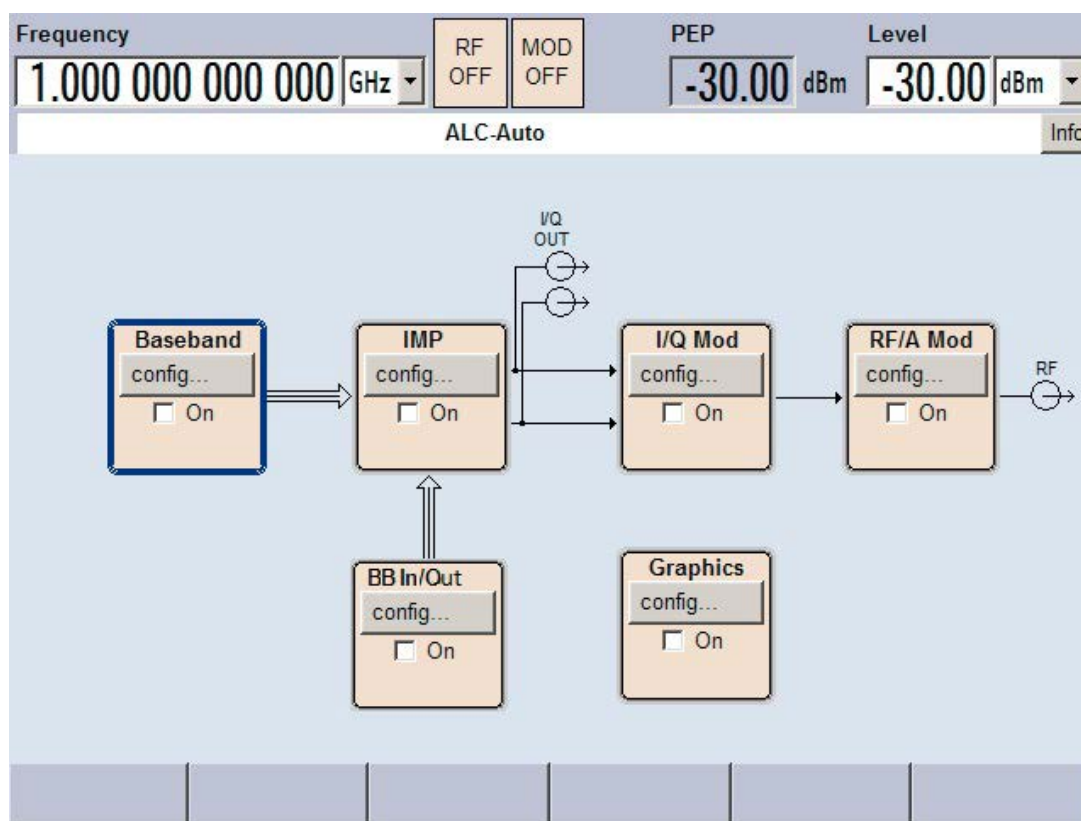

Figure 2. SMBV Front Panel

1. FM Analog Modulation in Mono Mode
 - a. Set Frequency = 98.1 MHz
 - b. Set Level = 60 dB μ V.
 - c. Hit config button on RF/A Mod block.
 - i. Select Frequency Mod under Analog Modulation
 - ii. FM Source = Int
 - iii. FM deviation = 22.5 kHz
 - iv. LFGGen Frequency = 1 kHz
 - v. State = ON (This turns on modulation)
 - vi. Close the config panel.
 - d. Click on the ON check box in the RF/A Mod block to turn RF ON

2. FM Analog Modulation in Stereo Mode
 - a. Set Frequency = 98.1 MHz
 - b. Set Level = 60 dB μ V.
 - c. Hit config button on Baseband block.
 - d. Select FM_STEREO under Broadcast Standards
 - i. Audio Settings
 1. Deviation = 22.5 kHz
 2. Audio Source = LF Generator
 3. LF Generator Frequency = 1 kHz
 4. Audio Mode = Left
 5. Preemphasis = 75 μ s
 - ii. Stereo Pilot Tone Settings
 1. Pilot State = ON
 2. Pilot Deviation = 6.75 kHz
 - iii. State = ON (This turns on modulation)
 - iv. Close the config panel.
 - e. Click on the ON check box in the RF/A Mod block to turn RF ON
3. FM Analog Modulation in Stereo Mode with RDS enabled
 - a. Set Frequency = 98.1 MHz
 - b. Set Level = 60 dB μ V.
 - c. Hit config button on Baseband block.
 - d. Select FM_STEREO under Broadcast Standards
 - i. Audio Settings
 1. Deviation = 22.5 kHz
 2. Audio Source = LF Generator
 3. LF Generator Frequency = 1 kHz
 4. Audio Mode = Left
 5. Preemphasis = 75 μ s
 - ii. Stereo Pilot Tone Settings
 1. Pilot State = ON
 2. Pilot Deviation = 6.75 kHz
 - iii. Click on RDS/RBDS Configurations
 1. State = ON
 2. Deviation = 2 kHz
 3. Program Identification set to 0x0123
 - iv. State = ON (This turns on modulation)
 - v. Close the config panel.
 - e. Click on the ON check box in the RF/A Mod block to turn RF ON
4. FMHD Digital Modulation
 - a. Set Frequency = 98.1 MHz
 - b. Set Level = -47 dBm.
 - c. Hit config button on Baseband block.
 - d. Select ARB

- i. Click on Load Waveform
 - ii. Select the test vector from the location on either SMBV hard drive or an external USB drive.
 - iii. Hit Select
 - iv. State = ON (This turns on modulation)
 - v. Close the config panel.
 - e. Click on the ON check box in the RF/A Mod block to turn RF ON
5. DAB Digital Modulation
- a. Set Frequency = 207.008 MHz
 - b. Set Level = -47 dBm.
 - c. Hit config button on Baseband block.
 - d. Select ARB
 - i. Click on Load Waveform
 - ii. Select the test vector from the location on either SMBV hard drive or an external USB drive.
 - iii. Hit Select
 - iv. State = ON (This turns on modulation)
 - v. Close the config panel.
 - e. Click on the ON check box in the RF/A Mod block to turn RF ON.
6. AM Analog Modulation
- a. Set frequency = 1 MHz
 - b. Set Level = 60 dB μ V
 - c. Hit config button on RF/A Mod block.
 - i. Select AM Modulation under Analog Modulation.
 - ii. Set AM Modulation Depth = 30%.
 - iii. Set Source = LFGEN (internal).
 - iv. Set LFGEN frequency = 1 kHz.
 - d. Click on the ON check box in the RF/A Mod block to turn RF ON.
7. AMHD Modulation
- a. Set Frequency=1 MHz
 - b. Set Level=60 dBuV
 - c. Hit config button on Baseband block.
 - d. Select ARB.
 - i. Click on Load Waveform.
 - ii. Select the test vector from the location on either SMBV hard drive or an external USB drive.
 - iii. Hit Select.
 - iv. State=ON. (This turns on modulation.)
 - v. Close the config panel.

2.2.2. SML Settings for FM Analog Test Cases

1. FM Analog Modulation in Mono Mode
 - a. Set RF Frequency = 98.1 MHz
 - b. Set RF Level = 60 dB μ V
 - c. Select FM Modulation.
 - i. FM Source = LFGEN
 - ii. FM Deviation = 22.5 kHz
 - iii. LFGen Freq = 1 kHz
 - d. Enable modulation. –MOD ON
 - e. Enable carrier. –RF ON
2. FM Analog Modulation in Stereo Mode
 - a. Set RF Frequency = 98.1 MHz
 - b. Set RF Level = 60 dB μ V
 - c. Select Stereo Modulation
 - i. Source = LFGEN
 - ii. FM Deviation = 22.5 kHz
 - iii. Mode = L = R
 - iv. LFGen Freq = 1 kHz
 - v. Preemphasis = 75 μ s
 - vi. Pilot State = ON
 - vii. Pilot Deviation = 6.75 kHz
 - d. Enable modulation. –MOD ON
 - e. Enable carrier. –RF ON
3. FM Analog Modulation in Stereo Mode with RDS enabled
 - a. Set RF Frequency = 98.1 MHz
 - b. Set RF Level = 60 dB μ V
 - c. Select Stereo Modulation
 - i. Source = LFGEN
 - ii. FM Deviation = 22.5 kHz
 - iii. Mode = L = R
 - iv. LFGen Freq = 1 kHz
 - v. Preemphasis = 75 μ s
 - vi. Pilot State = ON
 - vii. Pilot Deviation = 6.75 kHz
 - viii. Set RDS = ON
 - ix. Set RDS Deviation = 2 kHz
 - x. Set Program Identification set to 0x0123
 - xi. Set Traffic Announcement = OFF
 - xii. Set Traffic Program = OFF.
 - d. Enable modulation. –MOD ON
 - e. Enable carrier. –RF ON
4. AM Analog Modulation
 - a. Set RF Frequency = 1 MHz.

- b. Set RF Level = 60 dB μ V.
- c. Select AM Modulation.
 - i. Set AM Modulation Depth = 30%.
 - ii. Set Source = LFGEN (internal).
 - iii. Set LFGEN frequency = 1 kHz.
- d. Enable modulation. –MOD ON.
- e. Enable carrier. –RF ON.

3. FM Analog Radio Testing

This section covers FM analog radio testing for Si468x receivers. Table 2 provides a summary of tests and equipment used for FM analog radio tests.

Table 2. Si468x Analog FM Tuner Test Equipment

Test	Equipment
Sensitivity RDS Sensitivity AM Suppression Audio Output Voltage Audio Output L/R Imbalance Audio Band Limits Stereo Separation Audio THD Audio SINAD Audio SNR Pilot Suppression	Rohde & Schwarz UPV (or UPL) Audio Analyzer (with digital audio functionality) Rohde & Schwarz SMBV Signal Generator #1 (a Rohde & Schwarz SMB or SML with Stereo/RDS could also be sufficient) 2 x Agilent E3646A Power Supply* Mini-Circuits Power Combiner
Image Rejection Selectivity IP3	Equipment above plus: Rohde & Schwarz SMBV Signal Generator #2 (a Rohde & Schwarz SMB or SML with Stereo/RDS could also be sufficient)
*Note: You can power up the EVB through the USB port for these tests.	

Several issues must be considered to make accurate measurements.

First, the power combiner and cable losses must be calibrated and factored into each measurement. The loss for the Mini-Circuit power combiner is approximately 6 dB.

Second, most signal generators display the voltage generated at the input of the device under test (DUT) assuming an input resistance of 50Ω . For example, if the signal generator displays $V_L = 1 \mu\text{V}$ (0 dB μV), the generator source voltage V_S is $2 \mu\text{V}$ (6 dB μV). The load voltage V_L is generated from the source voltage V_S by the voltage divider created by the 50Ω generator source resistance R_S and the 50Ω load resistance R_L . This distinction is important only for sensitivity, RDS sensitivity, and IP3, which are specified in μV electromotive force (EMF), where EMF refers to the source voltage V_S . Measurements such as AM suppression, selectivity, and spurious response are relative and may be referenced using V_S or V_L . To summarize, the generator displays the voltage at the input of the DUT. In the case of Si468x FM tuner, input impedance is high; therefore, to convert the value displayed on the signal generator to EMF, double the voltage (add 6 dB).

3.1. FM Analog Radio Configuration

3.1.1. Si468x Standard Configuration

1. Set frequency = 98.1 MHz.
2. Tune the 46xx in tune mode = 0, FM analog mode.
3. Set mono = On. For mono only operation:
FM_BLEND_RSSI_LIMITS 0X7877
4. Set volume = 0x3F.
5. Set de-emphasis = 75 μ s.
6. Set soft mute = Off. For soft mute off:
FM_SOFTMUTE_SNR_ATTENUATION_ATTENMAX(dB) = 0
FM_SOFTMUTE_SNR_ATTENUATION_ATTENMIN(dB) = 0

3.1.2. Other FM Tuner Settings

Table 3. FM Tuner Settings

Tuner Setting	Si468x
Set RDS On	Set FM_RDS_CONFIG = 0x0001
Set AGC Off	Set AGC_OVERRIDE = 0x0003
Set Stereo Mode	FM_BLEND_RSSI_LIMIT = 0xEDEC FM_BLEND_SNR_LIMIT = 0XEDEC FM_BLEND_MULTIPATH_LIMIT = 0X6364

3.2. FM Analog Radio Test Procedures

The following procedures measure analog audio output.

3.2.1. Sensitivity

Sensitivity of a receiver is a measure of its ability to receive weak signals and produce an audio frequency output of usable magnitude and acceptable quality. Sensitivities may be defined with respect to many different characteristics of the output signal. For the purposes of our testing, sensitivity is the minimum RF level required to produce an audio output with a specified signal-to-noise and distortion ratio, 26 dB. Please note that the sensitivity measurement is defined with respect to SINAD and not SNR. Descriptions for these two measurements will be given in the following sections.

1. Connect test equipment as shown in Figure 1.
2. Configure the tuner in standard configuration.
3. Configure the audio analyzer:
 - f. Set Function = THD+N/SINAD.
 - g. Set Measurement Mode = SINAD.
 - h. Set Fundamental = 1000 Hz Fixed.
 - i. Set Unit = dB.
 - j. Set Filter = A-weighting.
 - k. Set Frequency Limit Low = 300 Hz.
 - l. Set Frequency Limit High = 15000 Hz.
 - m. Set Function Settling = Off (for quick measurement) or Average (for accurate measurement).
4. Configure generator #1 in FM Analog Modulation in Mono mode as described in "2.2. Signal Generator Settings" on page 3 with the following settings:
 - a. Carrier frequency = 98.1 MHz.
 - b. FM Deviation = 22.5 kHz.
 - c. LFGEN frequency = 1 kHz.
5. Disable generator #2.
6. Adjust generator #1 RF level, V_{RF0} , until audio analyzer SINAD = 26 dB.
7. Sensitivity (dB μ V) = V_{RF0} .

3.2.2. IP3

Intermodulation distortion in the detected or decoded audio-frequency signal may be caused by non-linearity in the radio-frequency, intermediate-frequency, and detector stages of the receiver. A good measure of intermodulation distortion is IP3. IP3 is the theoretical RF level at which two blockers (V_{RF1}), offset from the desired frequency by Δf and $2\Delta f$, and their intermodulation product (V_{RF0}) would be of the same amplitude, according to the equation $IP3 = V_{RF1} + \frac{1}{2}(V_{RF1} - V_{RF0})$.

V_{RF0} is the 26 dB SINAD sensitivity level at the fundamental frequency. V_{RF1} is the blocker level required to produce an inter-modulation product at the same sensitivity level.

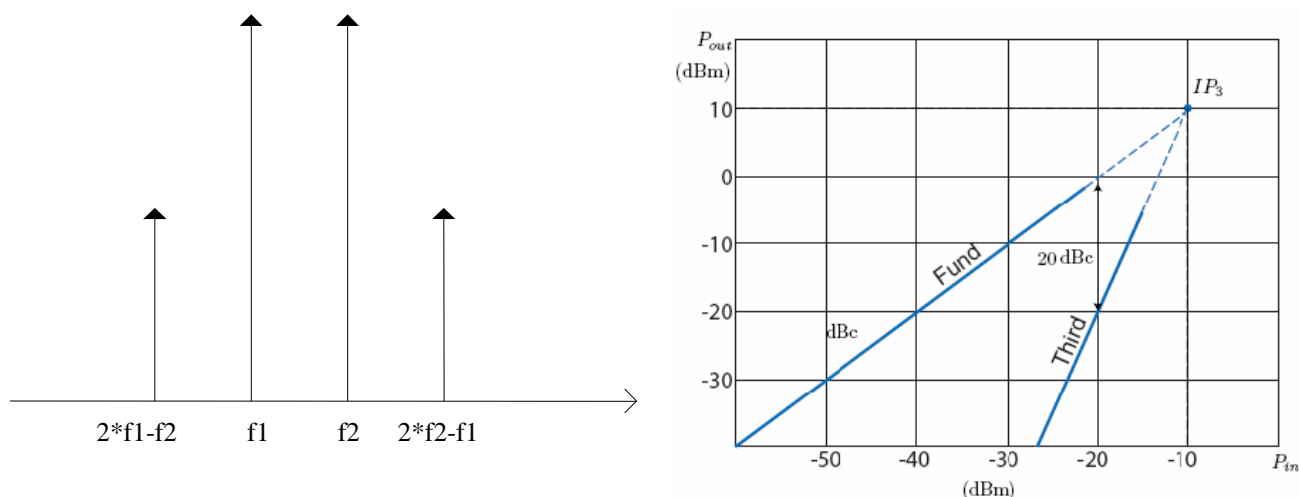

Figure 3. Graphical Representation of IP3

In our test:

- $f1 = 102.1$ MHz (blocker #1)
- $f2 = 106.1$ MHz (blocker #2)
- $2*f1-f2 = 98.1$ MHz (tuner frequency)

1. Connect test equipment as shown in Figure 1.
2. Make a sensitivity measurement, V_{RF0} , as described above.
3. Configure the tuner in standard configuration, except for the AGC setting. For this section of the test, set AGC OFF.
4. Configure the audio analyzer:
 - a. Select Analyze.
 - b. Set Function = THD+N / SINAD.
 - i. Set Measurement Mode = SINAD.
 - ii. Select Unit = dB.
5. Configure generator #1 in FM Analog Modulation in mono mode as described in "2.2. Signal Generator Settings" on page 3 with the following settings:
 - a. Carrier frequency = 106.1 MHz.
 - b. RF level = 70 dB μ V.
 - c. FM Deviation = 22.5 kHz.
 - d. LFGEN frequency = 1 kHz.

AN651

6. Configure generator #2 in FM Analog Modulation in mono mode as described in "2.2. Signal Generator Settings" on page 3 with the following settings:
 - a. Carrier frequency = 102.1 MHz.
 - b. RF level = 70 dB μ V.
 - c. Disable modulation.
 - d. Enable carrier.
7. Simultaneously adjust the generator #1 and generator #2 RF level, V_{RF1} , until SINAD = 26 dB.
8. $IP3 \text{ (dB}\mu\text{V)} = V_{RF1} + \frac{1}{2} (V_{RF1} - V_{RF0})$.

3.2.3. Adjacent / Alternate Channel Rejection

Rejection is a measure of the performance of a radio receiver to respond only to the tuned transmission (such as a radio station) and reject other signals nearby, such as another broadcast on an adjacent channel. The adjacent/alternate channel rejection tests are performed at -200 and -400 kHz offsets.

1. Configure the tuner in standard configuration:
 - a. Set Function = THD+N/SINAD.
 - b. Set Measurement Mode = SINAD.
 - c. Filter = A-weighting.
 - d. Frequency Limit Low = 300 Hz.
 - e. Frequency Limit High = 15000 Hz.
 - f. Set Frequency Mode = FIX: 1 kHz.
 - g. Function Setting = Off (for quick measurement) or Average (for accurate measurement).
 - h. Select Unit = dB.
2. Configure generator #1 in FM Analog Modulation in mono mode as described in "2.2. Signal Generator Settings" on page 3 with the following settings:
 - a. Carrier frequency = 98.1 MHz.
 - b. RF level VRF0 = 40 dB μ V.
 - c. FM Deviation = 22.5 kHz.
 - d. LFGEN frequency = 1 kHz.
3. Configure generator #2 in FM Analog Modulation in mono mode as described in "2.2. Signal Generator Settings" on page 3 with the following settings:
 - a. Set carrier frequency = 97.9 or 98.3 MHz (adjacent channel) or Set carrier frequency = 97.7 or 98.5 MHz (alternate channel).
 - b. FM Deviation = 22.5 kHz.
 - c. LFGEN frequency = 0.4 kHz.
4. Adjust generator #2 RF level, VRF1, until the SINAD level is 26 dB.
5. Rejection (dB) = VRF1 – VRF0.

3.2.4. AM Suppression

AM suppression of an FM receiver represents the ability of the receiver to reject AM of the input signal. AM might be a result of fading multi-path signals, aircraft flutter, AM at the transmitter, and AM introduced in the receiver by pass-band limitations and mistuning. AM suppression is measured as a ratio of voltage measured with an FM modulated signal to that of an AM modulated signal.

1. Connect test equipment as shown in Figure 1.
2. Configure the tuner in standard configuration.
3. Configure the audio analyzer:
 - a. Set Function = RMS Select.
 - i. Set Bandwidth = BP 3%.
 - ii. Set Units = dBV.
 - iii. Set Frequency Mode = FIX: 1 kHz.
4. Configure generator #1 in FM Analog Modulation in mono mode as described in "2.2. Signal Generator Settings" on page 3 with the following settings:
 - a. Carrier frequency = 98.1 MHz.
 - b. RF level = 60 dB μ V.
 - c. Select FM Modulation.
 - d. FM Deviation = 22.5 kHz.
 - e. LFGEN frequency = 1 kHz.
5. Record the audio level, VAUDIO₀.
6. Turn off generator #1 FM modulation.
7. Configure generator #1:
 - a. Carrier frequency = 98.1 MHz.
 - b. RF level = 60 dB μ V.
 - c. Select AM Modulation.
 - i. Set Depth = 30%.
 - ii. Set Source = LFGEN.
 - iii. Set LFGEN frequency = 1 kHz.
 - d. Enable modulation.
 - e. Enable carrier.
8. Record the audio level, VAUDIO₁.
9. AM Suppression (dB) = VAUDIO₀ – VAUDIO₁.

AN651

6. Configure generator #2 in FM Analog Modulation in mono mode as described in "2.2. Signal Generator Settings" on page 3 with the following settings:
 - a. Carrier frequency = 97.823 MHz (image at 258 kHz)*
 - b. FM Deviation = 22.5 kHz.
 - c. LFGEN frequency = 400 Hz.

Note: The IF frequency is 277 kHz for firmware 1.x.x and 258 kHz for 2.x.x and beyond.

7. Set generator#2 initially at VRF2. Increase the RF level of the image (generator #2) until SINAD drops back to 26 dB. Call this RF level VRF3.
8. Image rejection (dB) = VRF3 – VRF2.

3.2.6. RDS Sensitivity

RDS sensitivity is the minimum RF level required to produce an audio output with a specified Block Error Rate (BLER), 5%. BLER is a ratio of the number of data blocks received with at least one un-correctable bit to the number of blocks received.

1. Connect test equipment as shown in Figure 1.
2. Configure the tuner in standard configuration.
3. Set RDS ON.
4. Configure generator #1 in FM Analog Modulation in stereo mode with RDS enabled as described in "2.2. Signal Generator Settings" on page 3 with the following settings:
 - a. Carrier frequency = 98.1 MHz.
 - b. RF level = 4 μ V (target sensitivity level).
 - c. FM Deviation = 22.5 kHz.
 - d. Mode = LEFT.
 - e. LFGEN frequency = 1 kHz.
 - f. Set Pre-emphasis = 75 μ s.
 - g. Pilot Deviation = 6.75 kHz.
 - h. RDS Deviation = 2 kHz.
 - i. RDS Data Set = 1.
5. Disable generator #2.
6. Adjust generator #1 RF level, V_{RF0} , until BLER = 5%.*
7. Sensitivity (μ V) = V_{RF0} .

***Note:** Block Error Rate (BLER) measurement settles approximately in 20 seconds. Because the Silicon Laboratories automated test system configures the generator after the tuner, the BLER reading should be allowed to update twice before it is considered valid. Alternatively, the tuner could be configured after the generator and the BLER reading would be valid after one update.

3.2.7. RDS BLER

BLER stands for block error rate, which is a ratio of number of data blocks received with at least one un-correctable bit to the number of blocks received. This test is often used to test the RDS Sensitivity (BLER <5%) specification during production.

1. Connect test equipment as shown in Figure 1.
2. Configure the tuner in standard configuration.
3. Set RDS ON
4. Configure generator #1 in FM Analog Modulation in stereo mode with RDS enabled as described in "2.2. Signal Generator Settings" on page 3 with the following settings:
 - a. Carrier frequency = 98.1 MHz.
 - b. Set RF level = 7 μ V (target RDS sensitivity level + 3 μ V).
 - c. FM Deviation = 22.5 kHz.
 - d. Mode = LEFT.
 - e. LFGEN frequency = 1 kHz.
 - f. Pre-emphasis = 75 μ s.
 - g. Pilot Deviation = 6.75 kHz.
 - h. RDS Deviation = 2 kHz.
 - i. RDS Data Set = 1.
5. Read BLER * from the GUI after 22 seconds.

***Note:** Block Error Rate (BLER) measurement settles approximately in 20 seconds. Because the Silicon Laboratories automated test system configures the generator after the tuner, the BLER reading should be allowed to update twice before it is considered valid. Alternatively, the tuner could be configured after the generator and the BLER reading would be valid after an update.

3.2.8. RDS Persistence

RDS Sync is influenced by the signal quality and strength. Once the RDS is synchronized, the FM tuner has the ability to maintain its synchronization even with high BLER and fading signal strength. This test measures the ability to maintain RDS Sync in degrading signal condition.

1. Connect test equipment as shown in Figure 1.
2. Configure the tuner in standard configuration.
3. Set RDS ON.
4. Configure generator #1 in FM Analog Modulation in stereo mode with RDS enabled as described in "2.2. Signal Generator Settings" on page 3 with the following settings:
 - a. Carrier frequency = 98.1 MHz.
 - b. RF level = 4 μ V (RDS sensitivity level).
 - c. FM Deviation = 22.5 kHz.
 - d. Mode = LEFT.
 - e. LFGEN frequency = 1 kHz.
 - f. Pre-emphasis = 75 μ s.
 - g. Pilot Deviation = 6.75 kHz.
 - h. RDS Deviation = 2 kHz.
 - i. RDS Data Set = 1.
5. Slowly decrease the RF level until green "RDS" display on the main window of the Si47xx GUI goes off.
6. Record the RF level and BLER after 22 seconds.

3.2.9. THD Measurement

The total harmonic distortion, or THD, is a measurement of the harmonic distortion present at the audio output and is defined as the ratio of the sum of the powers of all harmonic components calculated in RMS fashion to the power of the fundamental.

3.2.9.1. Mono THD Measurement

1. Connect test equipment as shown in Figure 1.
2. Configure the tuner in standard configuration.
3. Configure the audio analyzer:
 - a. Set Function = THD.
 - b. Set Measurement Mode = All di (all harmonics).
 - c. Fundamental = 1000 Hz Fixed.
 - d. Equalizer = Off.
 - e. Function Settling = Off (for quick measurement) or Average (for accurate measurement).
 - f. Select Unit = %.
4. Configure generator #1 in FM Analog Modulation in Mono mode as described in "2.2. Signal Generator Settings" on page 3 with the following settings:
 - a. Carrier frequency = 98.1 MHz.
 - b. FM deviation = 75 kHz.
 - c. RF level = 60 dB μ V.
 - d. LFGEN frequency = 1 kHz.
5. Disable generator #2.
6. Record THD (%).

3.2.9.2. Stereo THD Measurement

1. Connect test equipment as shown in Figure 1.
2. Configure the tuner in stereo mode.
3. Configure the audio analyzer:
 - a. Set Function = THD.
 - b. Set Measurement Mode = All di (all harmonics).
 - c. Fundamental = 1000 Hz Fixed.
 - d. Equalizer = Off.
 - e. Function Settling = Off (for quick measurement) or Average (for accurate measurement).
 - f. Select Unit = %.
4. Configure generator #1 in FM Analog Modulation in Stereo mode as described in "2.2. Signal Generator Settings" on page 3 with the following settings:
 - a. Carrier frequency = 98.1 MHz.
 - b. FM Deviation = 67.5 kHz.
 - c. RF level = 60 dB μ V.
 - d. LFGEN frequency = 1 kHz.
 - e. Pilot deviation = 6.75 kHz.
 - f. Mode = Left.
 - g. Preemphasis = 75 μ s.
5. Disable generator #2.
6. Record THD (%).

3.2.10. SNR

The signal-to-noise ratio of a receiver, under specified conditions, is the ratio of the audio frequency output voltage due to the signal to that due to random noise. The noise may be measured using different filtering techniques. The technique used in this document is the A-weighting filter. Weighting filters are used to determine the loudness of sounds, particularly noise. A-weighting filter is commonly used to emphasize frequencies around 3–6 kHz, where the human ear is most sensitive, while attenuating very high and very low frequencies to which the ear is insensitive. The aim is to ensure that measured loudness corresponds well with subjectively perceived loudness. A-weighting is only really valid for relatively quiet sounds and for pure tones.

3.2.10.1. Mono SNR

1. Connect test equipment as shown in Figure 1.
2. Configure the tuner in standard configuration.
3. Configure the audio analyzer:
 - a. Set Function = THD+N / SINAD.
 - b. Set Measurement Mode = NOISE.
 - c. Set Units = dB.
 - d. Set Filter = A-weighting.
 - e. Set Frequency Limit Low = 300 Hz.
 - f. Set Frequency Limit Upper = 15000 Hz.
 - g. Set Function Settling = Off (for quick measurement) or Average (for accurate measurement)
4. Configure generator #1 in FM Analog Modulation in mono mode as described in "2.2. Signal Generator Settings" on page 3 with the following settings:
 - a. Carrier frequency = 98.1 MHz.
 - b. RF level = 60 dB μ V.
 - c. FM Deviation = 22.5 kHz.
 - d. LFGEN frequency = 1 kHz.
5. Record SNR (dB) = Noise (dB)

3.2.10.2. Stereo SNR

1. Connect test equipment as shown in Figure 1.
2. Configure the tuner in stereo mode.
3. Configure the audio analyzer:
 - a. Set Function = THD+N / SINAD.
 - b. Set Measurement Mode = NOISE.
 - c. Set Units = dB
 - d. Set Filter = A-weighting.
 - e. Set Frequency Limit Low = 300 Hz.
 - f. Set Frequency Limit Upper = 15000 Hz.
 - g. Function Settling = Off (for quick measurement) or Average (for accurate measurement).
4. Configure generator #1 in FM Analog Modulation in stereo mode as described in "2.2. Signal Generator Settings" on page 3 with the following settings:
 - a. Carrier frequency = 98.1 MHz.
 - b. FM Deviation = 67.5 kHz.
 - c. RF level = 60 dB μ V.
 - d. LFGEN frequency = 1 kHz.
 - e. Pilot deviation = 6.75 kHz.
 - f. Mode = Left.
 - g. Preemphasis = 75 μ s.
5. Record SNR (dB) = Noise (dB).

3.2.11. SINAD

Signal to noise and distortion (SINAD) is similar to signal to noise ratio, but includes distortion and is a ratio of "signal plus noise plus distortion" to "noise plus distortion." To make the SINAD measurement, a signal modulated with an audio tone is entered into the receiver. A measurement of the whole signal, *i.e.*, the signal plus noise plus distortion, is made by the audio analyzer. The audio tone is then removed by the analyzer and the remaining noise and distortion is measured.

3.2.11.1. Mono SINAD

1. Connect test equipment as shown in Figure 1.
2. Configure the tuner in standard configuration.
3. Configure the audio analyzer:
 - a. Set Function = THD+N / SINAD.
 - b. Set Measurement Mode = SINAD.
 - c. Set Units = dB.
 - d. Set Filter = A-weighting.
 - e. Set Frequency Limit Low = 300 Hz.
 - f. Set Frequency Limit Upper = 15000 Hz.
 - g. Set Function Settling = Off (for quick measurement) or Average (for accurate measurement)
4. Configure generator #1 in FM Analog Modulation in mono mode as described in "2.2. Signal Generator Settings" on page 3 with the following settings:
 - a. Carrier frequency = 98.1 MHz.
 - b. RF level = 60 dB μ V.
 - c. FM Deviation = 22.5 kHz.
 - d. LFGEN frequency = 1 kHz.
5. Record SINAD (dB) = SINAD (dB).

3.2.11.2. Stereo SINAD

1. Connect test equipment as shown in Figure 1.
2. Configure the tuner in stereo mode.
3. Configure the audio analyzer:
 - a. Set Function = THD+N / SINAD.
 - b. Set Measurement Mode = SINAD
 - c. Set Units = dB.
 - d. Set Filter = A-weighting.
 - e. Set Frequency Limit Low = 300 Hz.
 - f. Set Frequency Limit Upper = 15000 Hz.
 - g. Set Function Settling = Off (for quick measurement) or Average (for accurate measurement)
4. Configure generator #1 in FM Analog Modulation in stereo mode as described in "2.2. Signal Generator Settings" on page 3 with the following settings:
 - a. Carrier frequency = 98.1 MHz.
 - b. FM Deviation = 67.5 kHz.
 - c. RF level = 60 dB μ V.
 - d. LFGEN frequency = 1 kHz.
 - e. Pilot deviation = 6.75 kHz.
 - f. Mode = Left.
 - g. Preemphasis = 75 μ s.
5. Record SINAD (dB) = SINAD (dB).

3.2.12. Audio Output Voltage

Higher audio output voltage is an indicator of cleaner sound from the tuner. It is measured as an RMS value under standard operating conditions.

1. Connect test equipment as shown in Figure 1.
2. Configure the tuner in standard configuration.
3. Configure the audio analyzer:
 - a. Set Function = RMS Select.
 - i. Set Bandwidth = BP 3%.
 - ii. Set Units = V_{RMS} .
 - iii. Set Frequency Mode = FIX: 1 kHz.
4. Configure generator #1 in FM Analog Modulation in mono mode as described in "2.2. Signal Generator Settings" on page 3 with the following settings:
 - a. Carrier frequency = 98.1 MHz.
 - b. RF level = 60 dB μ V.
 - c. FM Deviation = 22.5 kHz.
 - d. LFGEN frequency = 1 kHz.
5. Audio level (V_{RMS}) = $VAUDIO_0$.

3.2.13. Audio L/R Imbalance

The level deviation between the two stereo channels is a quality criterion of the tuner because level differences shift the center for stereo sound impression. Audio L/R imbalance is the ratio of left to right channel output voltage.

1. Connect test equipment as shown in Figure 1.
2. Configure the tuner in standard configuration.
3. Configure the audio analyzer:
 - a. Set Function = RMS Select.
 - i. Set Bandwidth = BP 3%.
 - ii. Set Units = dBV.
 - iii. Set Frequency Mode = FIX: 1 kHz.
4. Configure generator #1 in FM Analog Modulation in mono mode as described in "2.2. Signal Generator Settings" on page 3 with the following settings:
 - a. Carrier frequency = 98.1 MHz.
 - b. RF level = 60 dB μ V.
 - c. Set FM Deviation = 75 kHz.
 - d. Set LFGEN frequency = 1 kHz.
5. Left channel audio level (dBV) = VAUDIO_L.
6. Right channel audio level (dBV) = VAUDIO_R.
7. Audio L/R imbalance (dB) = abs (VAUDIO_L – VAUDIO_R).

3.2.14. Audio Band Limits/Audio Frequency Response

The audio frequency response of a tuner is influenced by the quality of the IF section, detector, stereo coder and de-emphasis circuit. The emphasis of 75 μ s specified by the standards for VHF FM transmissions is simulated in the signal generator. This means that low-frequency audio signals are modulated with a low deviation. The frequency deviation is then increased by emphasis to the maximum permissible deviation at the upper frequency limit. This effect is compensated by the de-emphasis circuit in the tuner so that the frequency response of the audio signal becomes as linear as possible. Audio frequency response is the measure of linearity of output voltage vs. modulation frequency across the audio band.

The frequency response of pre-emphasis has the effect of a 1st order highpass filter with predefined time constant, in this case 75 μ s. Pre-emphasis with this time constant increases the signal by a factor of about 5.3 at 15 kHz relative to low frequencies. It is important to note that the maximum deviation of the system should not be exceeded even at high frequencies while pre-emphasis is on. Therefore, if measurements are performed at the modulation frequency with pre-emphasis on, the deviation should be adjusted so that the maximum permissible deviation is only attained at a modulation frequency of 15 kHz. In this case, the maximum deviation that can be adjusted for frequency response measurements is approximately 14%, 10.5 kHz. This influence must also be taken into account for measurements with the 1 kHz standard test frequency. For 1 kHz test frequency, the setting is approximately 90% at 75 μ s pre-emphasis.

1. Connect test equipment as shown in Figure 1.
2. Configure the tuner in standard configuration.
3. Configure the audio analyzer:
 - a. Set Function = RMS Select.
 - i. Set Bandwidth = BP 3%.
 - ii. Set Units = dBV.
 - iii. Set Frequency Mode = FIX: 1 kHz.
4. Configure generator #1 in FM Analog Modulation in stereo mode as described in "2.2. Signal Generator Settings" on page 3 with the following settings:
 - a. Carrier frequency = 98.1 MHz.
 - b. RF level = 60 dB μ V.
 - c. FM Deviation = 10.5 kHz.
 - d. Mode = L = R.
 - e. LFGEN frequency = 1 kHz.
 - f. Pre-emphasis = 75 μ s.
 - g. Pilot Deviation = 6.75 kHz.
5. Audio 1 kHz level (dBV) = $V_{1\text{kHz}}$.
6. Configure audio analyzer frequency mode through RMS Select Function.* Set Frequency Mode = FIX: 30 Hz.
7. Configure generator #1 LFGEN frequency = 30 Hz.
8. Audio 30 Hz level (dBV) = $V_{30\text{Hz}}$.
9. Configure audio analyzer frequency mode through RMS Select Function. Set Frequency Mode = FIX: 15 kHz.
10. Configure generator #1 LFGEN frequency = 15 kHz.
11. Audio 15 kHz level (dBV) = $V_{15\text{kHz}}$.
12. Audio frequency response (dB) equals the greater magnitude of $(V_{30\text{Hz}} - V_{1\text{kHz}})$ and $(V_{15\text{kHz}} - V_{1\text{kHz}})$.

***Note:** R&S audio analyzer should be set to 22 kHz analyzer mode to select this frequency mode.

3.2.15. Audio Stereo Separation

Crosstalk occurs when signal components of a channel are coupled into another audio channel. This reduces channel separation and thus impairs the stereo effect. Audio stereo separation is the level ratio of the wanted signal in a channel to the unwanted signal coupled into the other channel. Only the left channel is modulated and the levels are measured in both channels to obtain the ratio. To suppress the noise components, a selective measurement is carried out.

1. Connect test equipment as shown in Figure 1.
2. Configure the tuner in standard configuration, except for setting in mono operation. Set the tuner in stereo mode.
3. Configure the audio analyzer:
 - a. Set Function = RMS Select.
 - i. Set Bandwidth = BP 3%.
 - ii. Set Units = dBV.
 - iii. Set Frequency Mode = FIX: 1 kHz.
4. Configure generator #1 in FM Analog Modulation in stereo mode as described in "2.2. Signal Generator Settings" on page 3 with the following settings:
 - a. Carrier frequency = 98.1 MHz.
 - b. RF level = 60 dB μ V.
 - c. FM Deviation = 67.5 kHz.
 - d. Mode = Left.
 - e. Set LFGEN frequency = 1 kHz.
 - f. Pre-emphasis = 75 μ s.
 - g. Pilot Deviation = 6.75 kHz.
5. Left channel audio level (dBV) = VAUDIO_L.
6. Right channel audio level (dBV) = VAUDIO_R.
7. Audio Stereo Separation (dB) = abs (VAUDIO_L – VAUDIO_R).

3.2.16. Stereo Pilot Rejection

A pilot tone is transmitted at 19 kHz to identify stereo broadcast transmissions. In order not to disturb instruments such as amplifiers and recorders connected to the tuner, the pilot tone and its subcarriers must be sufficiently suppressed in the tuner. Stereo pilot rejection is the quality criterion of a tuner that is measured as the ratio of wanted audio frequency voltage to pilot frequency voltage according to the equation:

$$\text{Pilot Rejection} = V_{\text{audio0}} (1 \text{ kHz}) + 20 \cdot \log (\Delta_{\text{pilot}}/\Delta f) - V_{\text{audio0}} (19 \text{ kHz})$$

where Δf is FM frequency deviation and Δ_{pilot} is pilot frequency deviation.

1. Connect test equipment as shown in Figure 1.
2. Configure the tuner in standard configuration, except for setting in mono operation. Set the tuner in stereo mode.
3. Configure the audio analyzer:
 - a. Set Function = RMS Select.
 - i. Set Bandwidth = BP 3%.
 - ii. Set Units = dBV.
 - iii. Set Frequency Mode = FIX: 1 kHz.
4. Configure generator #1 in FM Analog Modulation in stereo mode as described in "2.2. Signal Generator Settings" on page 3 with the following settings:
 - a. Carrier frequency = 98.1 MHz.
 - b. RF level = 60 dB μ V.
 - c. FM Deviation = 67.5 kHz.
 - d. Mode = Left = Right.
 - e. LFGEN frequency = 1 kHz.
 - f. Pre-emphasis = 75 μ s.
 - g. Pilot Deviation = 6.75 kHz.
5. Audio 1 kHz level (dBV) = $V_{1\text{kHz}}$.
6. Configure audio analyzer frequency mode = FIX: 19 kHz.
7. Audio 19 kHz level (dBV) = $V_{19\text{kHz}}$.
8. Pilot Rejection (relative to pilot) (dB) = $V_{1 \text{ kHz}} - V_{19 \text{ kHz}} + 20 \cdot \log_{10} (\Delta_{\text{pilot}}/\Delta f) = V_{1 \text{ kHz}} - V_{19 \text{ kHz}} - 20$.
9. Pilot Rejection (relative to 75 kHz) (dB) = $V_{1 \text{ kHz}} - V_{19 \text{ kHz}} + 20 \cdot \log_{10} (75 \text{ kHz}/\Delta f) = V_{1 \text{ kHz}} - V_{19 \text{ kHz}} + 0.91$.

4. FMHD Radio Testing

This section covers testing the FMHD radio specs of the Si468x receivers. Table 4 provides a summary of tests and equipment.

Table 4. Si468x FMHD Receiver Test Equipment for FMHD Reception

Test	Equipment
Sensitivity (audio based) Sensitivity (BER based)	Rohde & Schwarz UPV (or UPL) Audio Analyzer (with digital audio functionality) Rohde & Schwarz SMBV Signal Generator #1 2 x Agilent E3646A Power Supply* Mini-Circuits Power Combiner
Image Rejection Selectivity IP3	Equipment above plus: Rohde & Schwarz SMBV Signal Generator #2 (a Rohde & Schwarz SMB or SML with Stereo/RDS could also be sufficient)
*Note: You can power up the EVB through the USB port for these tests.	

Several issues must be considered to make accurate measurements.

First, the power combiner and cable losses must be calibrated and factored into each measurement. The loss for the Mini-Circuits power combiner is approximately 6 dB for the entire FM band.

4.1. FMHD Radio Configuration

1. Set frequency = 98.1 MHz.
2. Tune Si468x FMHD receiver in tune mode = 3 for wideband digital only tune mode.

4.2. FMHD Radio Test Procedures

4.2.1. Sensitivity (Audio Based)

This test uses an HD test vector to produce a signal that will allow the measurement of an audio output tone with an audio analyzer (i.e., 1 kHz tone). Sensitivity is also commonly evaluated using a measurement of the Bit Error Rate (BER) presented as a separate procedure in section "4.2.2. Sensitivity (Bit Error Rate Based)" on page 32.

1. Connect test equipment as shown in Figure 1.
2. Tune the receiver to 98.1 MHz in tune mode 3 (see the Programming Guide, FM_tune_freq command).
3. Configure the audio analyzer:
 - a. Select Analyze.
 - b. Set Function = THD+N / SINAD.
 - c. Set Measurement Mode = SINAD.
 - d. Set Unit = dB.
 - e. Set Filter = A-weighting.
 - f. Set Frequency Limit Low = 30 Hz.
 - g. Set Frequency Limit High = 15000 Hz.
4. Configure generator #1 in FMHD Digital Modulation as described in "2.2. Signal Generator Settings" with the following settings:
 - a. Carrier frequency = 98.1 MHz
 - b. Select test file to produce 1 kHz tone
 - i. Load test vector IB_FMr208c_e1wfc08.wv
5. Disable generator #2.
6. Adjust generator #1 RF level, VRF0, until audio analyzer SINAD = 26 dB +/- 1 dB.
7. Sensitivity (dBm) = VRF0.

4.2.2. Sensitivity (Bit Error Rate Based)

This test uses a specified test vector and the receiver's built-in bit error rate (BER) measurement feature to determine the receiver's sensitivity

1. Connect test equipment as shown in Figure 1.
2. Tune the receiver to 98.1 MHz in tune mode 3 (see the Programming Guide, FM_Tune_Freq command).
3. Configure generator #1 FMHD Digital Modulation as described in "2.2. Signal Generator Settings" with the following settings:
 - a. Set carrier frequency = 98.1 MHz
 - b. Load BER test vector, IB_FMr208c_e1wfc204.wv
4. Disable generator #2.
5. Start the receiver BER test feature using the FMHD_TEST_BER_CONFIG property (see the Programming Guide for details).
6. Adjust generator #1 RF level, VRF0, until the BER reported = $5e-5$.
 - a. Note that if the receiver is re-tuned, you must restart the BER test
 - b. Audio will not be output while the BER test is enabled
7. Sensitivity (dBm) = VRF0.

4.2.3. Input IP3 Test

f1 = 102.1 MHz (blocker #1)

f2 = 106.1 MHz (blocker #2)

$2 \times f1 - f2 = 98.1$ MHz (tuner frequency)

1. Connect test equipment as shown in Figure 1.
2. Make a sensitivity measurement, VRF0, based on audio performance as described in section "4.2.1. Sensitivity (Audio Based)" on page 31.
3. Configure the tuner in standard configuration, except for the AGC setting. For this section of the test, set AGC OFF.
4. Configure the audio analyzer:
 - a. Select Analyze.
 - b. Set Function = THD+N / SINAD.
 - i. Set Measurement Mode = SINAD.
 - ii. Select Unit = dB.
5. Configure generator #1 in FM Analog Modulation in mono mode as described in section 2.4 with the following settings:
 - a. Carrier frequency = 106.1 MHz.
 - b. RF level = -47 dBm.
 - c. FM Deviation = 22.5 kHz.
 - d. Set LFGEN frequency = 1 kHz.
6. Configure generator #2 in FM Analog Modulation in mono mode as described in section 2.4 with the following settings:
 - a. Carrier frequency = 102.1 MHz.
 - b. RF level = -47 dBm.
 - c. Disable modulation.
 - d. Enable carrier.
7. Simultaneously adjust the generator #1 and generator #2 RF level, VRF1, until SINAD = 26 dB.
8. $IP3 \text{ (dB}\mu\text{V)} = VRF1 + 1/2 (VRF1 - VRF0)$.

4.2.4. 1st Adjacent/2nd Adjacent Selectivity

1. Connect test equipment as shown in Figure 1.
2. Configure generator #1 in FMHD Digital Modulation as described in “2.2. Signal Generator Settings” with the following settings:
 - a. Carrier frequency = 98.1 MHz.
 - b. RF level VRF0 = -65 dBm.
 - c. Load BER test vector, IB_FMr208c_e1wfc204.wv
3. Configure generator #2 in FM Analog Modulation in mono mode as described in “2.2. Signal Generator Settings” with the following settings:
 - a. Carrier frequency = 98.3/97.9 MHz (1st adjacent channel) or
 - b. Carrier frequency = 98.5/97.7 MHz (2nd adjacent channel).
 - c. RF level = -47 dBm.
 - d. FM Deviation = 22.5 kHz.
 - e. LFGEN frequency = 1 kHz.
4. Start the receiver BER test feature using the FMHD_TEST_BER_CONFIG property (see the Programming Guide for details).
5. Adjust generator #2 RF level, VRF1, until the BER reported = 5e-5.
 - a. Note that if the receiver is re-tuned, you must restart the BER test
 - b. Audio will not be output while the BER test is enabled
6. Selectivity (dB) = VRF1 – VRF0.

4.2.5. Far-Off Selectivity (+/-4MHz)

1. Connect test equipment as shown in Figure 1.
2. Configure generator #1 in FMHD Digital Modulation as described in “2.2. Signal Generator Settings” with the following settings:
 - a. Carrier frequency = 98.1 MHz.
 - b. RF level VRF0 = -65 dBm.
 - c. Load BER test vector, IB_FMr208c_e1wfc204.wv
3. Configure generator #2 in FM Analog Modulation in mono mode as described in “2.2. Signal Generator Settings” with the following settings:
 - a. Carrier frequency = 102.1/94.1 MHz
 - b. RF level = -47 dBm.
 - c. FM Deviation = 22.5 kHz.
 - d. LFGEN frequency = 1 kHz.
4. Start the receiver BER test feature using the FMHD_TEST_BER_CONFIG property (see the Programming Guide for details).
5. Adjust generator #2 RF level, VRF1, until the BER reported = 5e-5.
 - a. Note that if the receiver is re-tuned, you must restart the BER test
 - b. Audio will not be output while the BER test is enabled
6. Selectivity (dB) = VRF1 – VRF0.

4.2.6. Image Rejection

1. Connect test equipment as shown in Figure 1.
2. Configure generator #1 in FMHD Digital Modulation as described in “2.2. Signal Generator Settings” with the following settings:
 - a. Carrier frequency = 98.1 MHz.
 - b. RF level VRF0 = -65 dBm.
 - c. Load BER test vector, IB_FMr208c_e1wfc204.wv
3. Configure generator #2 in FM Analog Modulation in mono mode as described in “2.2. Signal Generator Settings” with the following settings:
 - a. Carrier frequency, -416 kHz offset = 97.684 MHz
 - b. RF level = -47 dBm.
 - c. FM Deviation = 22.5 kHz.
 - d. LFGEN frequency = 1 kHz.
4. Start the receiver BER test feature using the FMHD_TEST_BER_CONFIG property (see the Programming Guide for details).
5. Adjust generator #2 RF level, VRF1, until the BER reported = 5e-5.
 - a. Note that if the receiver is re-tuned, you must restart the BER test
 - b. Audio will not be output while the BER test is enabled
6. Image Rejection (dB) = VRF1 – VRF0.

5. AM Analog Radio Testing

This section covers testing the AM specs for the Si468x receiver. Table 5 provides a summary of tests and equipment.

Table 5. AM Tuner Test Equipment

Test	Equipment
Sensitivity Audio Output Voltage Audio THD Audio SNR Audio SINAD	Rohde & Schwarz UPV Audio Analyzer (with digital audio functionality) Rohde & Schwarz SMB USB Power Supply*
Image Rejection Adjacent/Alternate Channel Rejection IP3	Equipment above plus: Rohde & Schwarz SMB Signal Generator #2 Mini Circuits ZSC-3-2 0-30MHz or equivalent 3 to 1 combiner (required for IP2) OR Mini Circuits ZFRSC-42-S+ 0-4.2GHz or 2 to 1 Combiner (if not running the IP3 tests)
*Note: You can power up the EVB through two Agilent E3646A Power Supplies.	

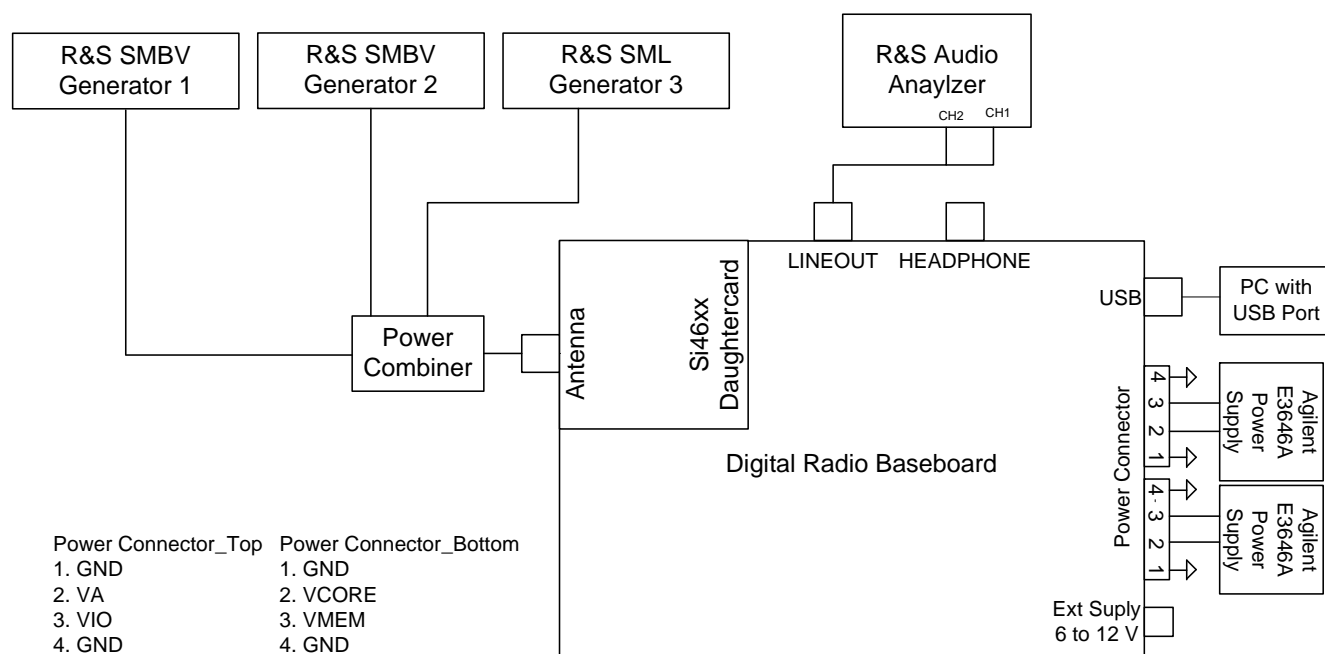

Figure 5. Si468x Test Setup

5.1. AM Tuner Testing Calibration

During testing power combiner and cable losses must be calibrated and factored into each measurement. The calibration is performed by setting the Generator#1 at 1 MHz and 0 dBm and measuring the RF power at the DUT. The calibration factor is either programmed as an offset to the generator or manually compensated during measurement. All the levels specified in this document are the levels that should be set at the DUT.

5.2. AM Tuner Configuration

The AM tuner is set to following common configuration. It is not necessary to set the following properties during AM testing. The user can run the AM tests by configuring the AM frequency and using the power up defaults (by just booting up the tuner using GUI). However, the following setups enhance the measurement speed, and can be used if the user is running automated tests.

Property	Value	Property Address	Property Value to Set
Input Frequency	1000 kHz		
Volume	63 (max)	0x0300	0x003F
AGC_Override	RF AGC Disabled	0x1700	0x0001

5.3. AM Tuner Testing Procedures

The following procedures describe AM tuner measurements.

5.3.1. Sensitivity

Sensitivity of a receiver is a measure of its ability to receive weak signals and produce an audio frequency output of usable magnitude and acceptable quality. Sensitivities may be defined with respect to many different characteristics of the output signal. For the purposes of our testing, sensitivity is the minimum RF level required to produce an audio output with a specified signal-to-noise and distortion ratio (SINAD), of 20 dB. Note that the sensitivity measurement is defined with respect to SINAD and not SNR. Descriptions for these two measurements will be given in the following sections.

1. Configure the audio analyzer:
 - a. Set Function = THD+N/SINAD.
 - b. Set Measurement Mode = SINAD.
 - c. Set Unit = dB.
 - d. Set Filter = OFF.
 - e. Set Frequency Limit Low = 30 Hz.
 - f. Set Frequency Limit High = 15000 Hz.
 - g. Fundamental = 1000 Hz fixed function.
2. Configure generator #1:
 - a. Set carrier frequency = 1 MHz.
 - b. Select AM Modulation.
 - c. Set AM Modulation Depth = 30%.
 - d. Set source = LFGEN (internal). Set LFGEN frequency = 1 kHz.
 - e. Enable AM modulation. Enable RF carrier.
3. Disable generator #2.
4. Adjust generator #1 RF level, VRF0, until audio analyzer SINAD = 20 dB.
5. Sensitivity = VRF0 (dBuV).

5.3.2. SNR

The signal-to-noise ratio of a receiver, under specified conditions, is the ratio of the audio frequency output voltage due to the signal to that due to random noise. This test is performed at standard (30%) and High (90%) modulation depth as well as normal (74 dB μ V) and strong (120 dB μ V) signal levels.

1. Configure the audio analyzer to record noise.
 - a. Set Function = THD+N/SINAD.
 - b. Set Measurement Mode = Noise.
 - c. Set Unit = dB.
 - d. Set Frequency Mode = FIX: 1 kHz.
 - e. Set Filter = OFF.
 - f. Set Frequency Limit Low = 30 Hz.
 - g. Set Frequency Limit High = 15000 Hz.
2. Configure generator #1:
 - a. Set carrier frequency = 1 MHz.
 - b. Set RF level = 60 dB μ V.
 - c. Select AM Modulation.
 - d. Set AM Modulation Depth = 30%. (90% for high Modulation depth measurement).
 - e. Set Source = LFGEN (internal). Set LFGEN frequency = 1 kHz.
 - f. Enable AM modulation. Enable RF carrier.
3. Disable generator #2.
4. Record Noise (dB) from analyzer.
5. Record SNR (dB) = Noise (dB).

5.3.3. THD

The total harmonic distortion, or THD, is a measurement of the harmonic distortion present at the audio output and is defined as the ratio of the sum of the powers of all harmonic components calculated in RMS fashion to the power of the fundamental. This test is performed at standard (30%) and high (90%) modulation depth as well as normal (74 dB μ V) and strong (120 dB μ V) signal levels.

1. Configure the audio analyzer:
 - a. Function= THD.
 - b. Measurement Mode= All di.
 - c. Fundamental= 1000 Hz fixed.
 - d. Equalizer = OFF.
 - e. Function Setting = Off (for quick measurement) or Average (for accurate measurement).
 - f. Select Unit = %.
2. Configure generator #1:
 - a. Set carrier frequency = 1 MHz.
 - b. Set RF level = 60 dB μ V.
 - c. Select AM Modulation.
 - d. Set AM Modulation Depth = 30% (90% for high Modulation depth measurement).
 - e. Set Source = LFGEN (internal).
 - f. Set LFGEN frequency = 1 kHz.
 - g. Enable AM modulation. Enable RF (carrier).
3. Disable generator #2.
4. Record THD (%).

5.3.4. SINAD

Signal to noise and distortion (SINAD) is similar to signal to noise ratio, but includes distortion. A measurement of the whole signal, i.e., the signal plus noise plus distortion, is made by the audio analyzer. The audio tone is then removed by the analyzer and the remaining noise and distortion is measured. This test is performed at standard (30%) and High (90%) modulation.

depth

1. Configure the audio analyzer:
 - a. Set Function = THD+N/SINAD.
 - b. Set Measurement Mode = SINAD.
 - c. Fundamental: 1000 Hz fixed.
 - d. Filter = OFF.
 - e. Frequency Limit Low = 30 Hz.
 - f. Frequency Limit High = 15000 Hz.
 - g. Function Setting: Off (for quick measurement) or Average (for accurate measurement).
 - h. Select Unit = dB.
2. Configure generator #1:
 - a. Set carrier frequency = 1 MHz
 - b. Set RF level = 60 dB μ V.
 - c. Select AM Modulation.
 - d. Set AM Modulation Depth = 30% (90% for high Modulation depth measurement).
 - e. Set Source = LFGEN (internal).
 - f. Set LFGEN frequency = 1 kHz.
 - g. Enable AM modulation. Enable RF (carrier).
3. Enable modulation. Enable carrier.
4. Disable generator #2.
5. Record SINAD (dB).

5.3.5. Output Voltage

1. Configure the audio analyzer:
 - a. Set Function = RMS Select.
 - b. Set Bandwidth = BP 3%.
 - c. Set Units = V_{RMS}.
 - d. Set Frequency Mode = FIX: 1 kHz.
2. Configure generator #1:
 - a. Set carrier frequency = 1 MHz.
 - b. Set RF level = 60 dB μ V.
 - c. Select AM Modulation.
 - d. Set AM Modulation Depth = 30%.
 - e. Set Source = LFGEN (internal).
 - f. Set LFGEN frequency = 1 kHz.
 - g. Enable AM modulation. Enable RF (carrier).
3. Disable generator #2.
4. Record audio level (V_{rms}) from the analyzer.

5.3.6. Adjacent/Alternate Channel Rejection

Rejection is a measure of the performance of a radio receiver to respond only to the tuned transmission (such as a radio station) and reject other signals nearby, such as another broadcast on an adjacent channel. Adjacent channel rejection measures the interference from an unwanted signal present one band spacing away (9 kHz away). Alternate channel rejection measures the interference from an unwanted signal present two band spacing away (18 kHz away).

1. Configure the audio analyzer:
 - a. Set Function = THD+N/SINAD.
 - b. Set Measurement Mode = SINAD.
 - c. Filter = OFF
 - d. Frequency Limit Low = 30 Hz.
 - e. Frequency Limit High = 15000 Hz
 - f. Set Frequency Mode = FIX: 1 kHz.
 - g. Select Unit = dB.
2. Configure generator #1:
 - a. Set carrier frequency = 1 MHz.
 - b. Set RF level VRF0= 22 dB μ V.
 - c. Select AM Modulation.
 - d. Set AM Modulation Depth = 30%.
 - e. Set Source = LFGEN (internal).
 - f. Set LFGEN frequency = 1 kHz.
 - g. Enable AM modulation. Enable RF carrier.
3. Configure generator #2:
 - a. Set carrier frequency = 0.990 MHz (adjacent channel), or
 - b. Set carrier frequency = 0.980 MHz (alternate channel).
 - c. Select AM Modulation.
 - d. Set AM Modulation Depth = 30%.
 - e. Set Source = LFGEN (internal).
 - f. Set LFGEN frequency = 400 Hz.
 - g. Enable AM Modulation. Enable RF carrier.
4. Adjust generator #2 RF level, VRF1, until the sinad = 20 dB.
5. Rejection (dB) = VRF1 – VRF0.

5.3.7. Image Rejection

This test measures the image rejection at negative 258 kHz offset from the carrier frequency.

1. Configure the audio analyzer:
 - a. Set Function = RMS & S/N.
 - b. Set Units = dBV.
2. Configure generator #1:
 - a. Set carrier frequency = 1 MHz.
 - b. Set AM Modulation Depth = 30%.
 - c. Set Source = LFGEN (internal).
 - d. Set LFGEN frequency = 1 kHz.
 - e. Set signal level VRF1 = 45 dB μ V.
 - f. Enable modulation.
 - g. Enable carrier.
3. Configure generator #2:
 - a. Set carrier frequency = 742 kHz.
 - b. Set image level VRF2 = 75 dB μ V.
 - c. Enable generator.
4. Set audio analyzer and read the (message) level value VAUDIO0
5. Disable the modulation on generator # 1.
6. Set audio analyzer and read the (image) level value VAUDIO1
7. $V_{\text{AudioRelative}} = \text{VAUDIO0} - \text{VAUDIO1}$.
8. $V_{\text{RFRelative}} = \text{VRF2} - (\text{VRF1} + 20.0 \times \text{Math.Log10}(0.3))$.
9. Image Rejection = $V_{\text{AudioRelative}} + V_{\text{RFRelative}}$.

5.3.8. IP3

Intermodulation distortion in the detected or decoded audio-frequency signal may be caused by non-linearity in the radio-frequency, intermediate-frequency, and detector stages of the receiver. A good measure of intermodulation distortion is IP3. IP3 is the theoretical RF level at which two blockers (VRF1), offset from the desired frequency by Δf and $2\Delta f$, and their intermodulation product.

In our test:

- $f_1 = 1100.2 \text{ kHz}$ (blocker #1) $f_2 = 1200 \text{ kHz}$ (blocker #2)
 - $2 \times f_1 - f_2 = 1.0004 \text{ MHz}$ (400 Hz away from tuner frequency)
1. The IP3 test requires that Si468x receiver should be set in standard configuration except with the RF AGC disabled. RF AGC is disabled by setting property 0x1700 to 1.
 2. Configure the audio analyzer:
 - a. Set Function = RMS Select.
 - b. Set Bandwidth = BP 3%.
 - c. Set Units = dBV.
 - d. Set Frequency Mode = FIX: 1 kHz.
 3. Configure generator #1 (For the carrier signal):
 - a. Set carrier frequency = 1000 kHz.
 - b. Set RF level = 30 dB μ V (VRF_message).
 - c. Select AM Modulation.
 - d. Set AM Modulation Depth = 30%.
 - e. Set Source = LFGEN (internal).

-
- f. Set LFGEN frequency = 1 kHz.
 - g. Enable modulation. Enable carrier.
 4. Configure generator #2 (For the blocker#1 signal):
 - a. Set carrier frequency = 1100.2 kHz.
 - b. Set RF level = 70 dB μ V (VRF_blocker).
 - c. Enable carrier.
 5. Configure generator #3 (For the blocker#2 signal):
 - a. Set carrier frequency = 1200 kHz.
 - b. Set RF level = 70 dB μ V (VRF_blocker).
 - c. Enable carrier.
 6. Read the message level rms value (due to carrier at 1kHz) displayed in the analyzer by setting fixed frequency to 1000 kHz (Vrms_message (dBV))
 7. Disable modulation on generator #1.
 8. Setup Analyzer at fixed frequency of 400 Hz (blocker)
 9. Read the blocker level rms value (due to blocker at 400 Hz) displayed in the analyzer (Vrms_blocker (dBV))
 10. Calculate IP3
 - a. $RelativeLevel = (Vrms_message - Vrms_blocker)$
 - b. $MessageInputLevel = VRF_message + 20.0 \times Math.Log10(0.3)$
 - c. $BlkMessageInputLevel = MessageInputLevel - RelativeLevel$
 - d. $IP3 = VRF_blocker + ((VRF_blocker - BlkMessageInputLevel)/2)$

6. AMHD Radio Testing

This section covers testing the AMHD radio specs of the Si468x receiver. Table 4 provides a summary of tests and equipment.

Table 6. Si468x AMHD Receiver Test Equipment for FMHD Reception

Test	Equipment
Sensitivity (audio based) Sensitivity (BER based)	Rohde & Schwarz UPV (or UPL) Audio Analyzer (with digital audio functionality) Rohde & Schwarz SMBV Signal Generator #1 2 x Agilent E3646A Power Supply* Mini-Circuits Power Combiner
Selectivity	Equipment above plus: Rohde & Schwarz SMBV Signal Generator #2 (a Rohde & Schwarz SMB or SML with Stereo/RDS could also be sufficient)
*Note: You can power up the EVB through the USB port for these tests.	

Several issues must be considered to make accurate measurements.

First, the power combiner and cable losses must be calibrated and factored into each measurement. The loss for the Mini-Circuits power combiner is approximately 5 dB for the entire AM band.

6.1. AMHD Radio Configuration

1. Set frequency = 1 MHz.
2. Tune Si468x AMHD receiver in blend mode = 2.

6.2. AMHD Radio Test Procedures

6.2.1. Sensitivity (Audio Based)

This test uses an HD test vector to produce a signal that will allow the measurement of an audio output tone with an audio analyzer (i.e., 1 kHz tone). Sensitivity is also commonly evaluated using a measurement of the Bit Error Rate (BER) presented as a separate procedure in section "6.2.2. Sensitivity (Bit Error Rate Based)" on page 45.

1. Connect test equipment as shown in Figure 1.
2. Tune the receiver to 1 MHz in tune mode 2 (see the Programming Guide, AM_tune_freq command).
3. Configure the audio analyzer:
 - a. Select Analyze.
 - b. Set Function = THD+N / SINAD.
 - c. Set Measurement Mode = SINAD.
 - d. Set Unit = dB.
 - e. Set Frequency Limit Low = 30 Hz.
 - f. Set Frequency Limit High = 15000 Hz.
4. Configure generator #1 in FMHD Digital Modulation as described in "2.2. Signal Generator Settings" with the following settings:
 - a. Carrier frequency = 1 MHz
 - b. Select test file to produce 1 kHz tone
 - i. Load test vector IB_AMr208a_e1awfb00.wv
5. Disable generator #2.
6. Adjust generator #1 RF level, VRF0, until audio analyzer SINAD = 20 dB \pm 1 dB.
7. Sensitivity (dBm) = VRF0.

6.2.2. Sensitivity (Bit Error Rate Based)

This test uses a specified test vector and the receiver's built-in bit error rate (BER) measurement feature to determine the receiver's sensitivity

1. Connect test equipment as shown in Figure 1.
2. Tune the receiver to 1 MHz in tune mode 2 (see the Programming Guide, FM_Tune_Freq command).
3. Configure generator #1 AMHD Digital Modulation as described in "2.2. Signal Generator Settings" with the following settings:
 - a. Set carrier frequency = 1 MHz
 - b. Load BER test vector, IB_FMr208c_e1wfc204.wv
4. Disable generator #2.
5. Start the receiver BER test feature using the AMHD_TEST_BER_CONFIG property (see the Programming Guide for details).
6. Adjust generator #1 RF level, VRF0, until the BER reported = $1e-4$.
 - a. Note that if the receiver is re-tuned, you must restart the BER test
 - b. Audio will not be output while the BER test is enabled
7. Sensitivity (dBm) = VRF0.

6.2.3. 1st Adjacent/2nd Adjacent Selectivity

1. Connect test equipment as shown in Figure 1.
2. Configure generator #1 in AMHD Digital Modulation as described in “2.2. Signal Generator Settings” with the following settings:
 - a. Carrier frequency = 1 MHz.
 - b. RF level VRF0 = 32 dB μ V.
 - c. Load BER test vector, IB_AMr208a_e1awfb00.wv
3. Configure generator #2 in AM Analog Modulation as described in “2.2. Signal Generator Settings” with the following settings:
 - a. Carrier frequency = 1010/990 kHz (1st adjacent channel) or
 - b. Carrier frequency = 1020/980 kHz (2nd adjacent channel).
 - c. RF level = 50 dB μ V.
 - d. Set AM Modulation Depth = 30%.
 - e. Set Source = LFGEN (internal).
 - f. Set LFGEN frequency = 1 kHz.
4. Start the receiver BER test feature using the AMHD_TEST_BER_CONFIG property (see the Programming Guide for details).
5. Adjust generator #2 RF level, VRF1, until the BER reported = 1.0e-4.
 - a. Note that if the receiver is re-tuned, you must restart the BER test
 - b. Audio will not be output while the BER test is enabled
6. Selectivity (dB) = VRF1 – VRF0.

7. DAB Radio Testing

This section covers testing the DAB radio testing of the Si468x receivers. Table 7 provides a summary of tests and equipment.

Table 7. Si468x DAB Receiver Test Equipment for DAB Reception

Test	Equipment
Sensitivity (audio based) Sensitivity (BER based) Audio THD Audio SNR Audio SINAD	Rohde & Schwarz UPV (or UPL) Audio Analyzer (with digital audio functionality) Rohde & Schwarz SMBV Signal Generator #1 2 x Agilent E3646A Power Supply* Mini-Circuits Power Combiner
Half-band FM Blocker Selectivity Selectivity	Equipment above plus: Rohde & Schwarz SMBV Signal Generator #2
*Note: You can power up the EVB through the USB port for these tests.	

First, the power combiner and cable losses must be calibrated and factored into each measurement. The loss for the Mini-Circuits power combiner is approximately 5.2 dB for the entire DAB band.

7.1. DAB Radio Configuration

1. Set frequency = 207.008 MHz.
2. Tune Si468x DAB receiver.

7.2. DAB Radio Test Procedures

7.2.1. Sensitivity (Bit Error Rate Based)

This test uses a specified test vector and the receiver's built-in bit error rate (BER) measurement feature to determine the receiver's sensitivity.

1. Connect test equipment as shown in Figure 1 on page 2.
2. Configure generator #1 DAB Digital Modulation as described in "2.2. Signal Generator Settings" on page 3 with the following settings:
 - a. Set carrier frequency = 207.008 MHz.
 - b. Load BER test vector, BER_NullPattern_test2.eti.
3. Disable generator #2.
4. Tune the receiver to 207.008 MHz (see the Programming Guide, DAB_Tune_Freq command).
5. Acquire a list of digital services (see the Programming Guide, Get_Digital_Service_List command).
6. Start digital service (see the Programming Guide, Start_Digital_Service).
 - a. Digital Service ID = 0xE1C00001.
 - b. Component = 0xE001.
7. Start the receiver BER test feature using the DAB_Test_Get_BER_Info property (see the Programming Guide for details).
8. Adjust generator #1 RF level, VRF0, until the BER reported = 1e-4.
 - a. Note that if the receiver is re-tuned, you must restart the BER test.
 - b. Audio will not be output while the BER test is enabled.
9. Sensitivity (dBm) = VRF0*

***Note:** It is recommended to acquire at least 1 million points for each BER measurement.

7.2.2. Sensitivity (Audio Based)

1. Connect test equipment as shown in Figure 2 on page 3.
2. Configure generator #1 DAB Digital Modulation as described in section “2.2. Signal Generator Settings” with the following settings:
 - a. Set carrier frequency = 207.008 MHz.
 - b. Load test vector, SilabsEnsembleTones07.eti.
3. Disable generator #2.
4. Tune the receiver to 207.008 MHz (see the Programming Guide, DAB_Tune_Freq command).
5. Acquire a list of digital services (see the Programming Guide, Get_Digital_Service_List command).
6. Start digital service (see the Programming Guide, Start_Digital_Service).
 - a. Digital Service ID = 0x0000c000.
 - b. Component = 0x0000.
7. Configure the audio analyzer:
 - a. Select Analyze.
 - b. Set Function = THD+N / SINAD.
 - c. Set Measurement Mode = SINAD.
 - d. Set Unit = dB.
 - e. Set Filter = A-weighting.
 - f. Set Frequency Limit Low = 30 Hz.
 - g. Set Frequency Limit High = 15000 Hz.
 - h. Adjust generator #1 RF level, VRF0, until audio analyzer SINAD \leq 26 dB.
8. Sensitivity (dBm) = VRF0

7.2.3. Adjacent Channel Selectivity

1. Connect test equipment as shown in Figure 1 on page 2.
2. Configure generator #1 as described in “2.2. Signal Generator Settings” with the following settings:
 - a. Frequency = 195.936 MHz.
 - b. RF level = -70 dBm.
 - c. Test Vector = BER_NullPattern_test2.eti.
3. Tune the receiver to 195.936 MHz (see the Programming Guide, DAB_Tune_Freq command).
4. Acquire a list of digital services (see the Programming Guide, Get_Digital_Service_List command).
5. Start digital service (see the Programming Guide, Start_Digital_Service).
 - a. Digital Service ID = 0xE1C00001.
 - b. Component = 0xE001.
6. Configure generator #2 as described in “2.2. Signal Generator Settings” with the following settings:
 - a. Frequency = 194,224/197,648 MHz (first adjacent), or
 - b. Frequency = 192,512/199,360 MHz (second adjacent), or
 - c. Frequency = 190,800/201,072 MHz (third adjacent).
 - d. RF level = -47 dBm.
 - e. Test Vector = BER_NullPattern_test2.eti*
- *Note: Generator #2's output must be compliant to the RF mask specified in Figure 3 of EN50248: Characteristics of DAB Receivers (Aug, 2001).
7. Start the receiver BER test feature using the DAB_Test_Get_BER_Info property (see the Programming Guide for details).
8. Adjust the generator #2 RF level, VRF1, until the BER reported = $1e-4$.
9. Selectivity (dB) = VRF1 - VRF0.

Note: VRF0 is the RF level of generator #1.

7.2.4. Half-Band FM Blocker Selectivity

1. Connect test equipment as shown in Figure 1 on page 2.
2. Configure generator #1 as described in "2.2. Signal Generator Settings" on page 3 with the following settings:
 - a. Frequency = 195.936 MHz.
 - b. RF level = -65 dBm.
 - c. Test Vector = BER_NullPattern_test2.eti.
3. Tune the receiver to 195.936 MHz (see the Programming Guide, DAB_Tune_Freq command).
4. Acquire a list of digital services (see the Programming Guide, Get_Digital_Service_List command).
5. Start digital service (see the Programming Guide, Start_Digital_Service).
 - a. Digital Service ID = 0xE1C00001.
 - b. Component = 0xE001.
6. Configure generator #2 in FM Analog Modulation in mono mode as described in "2.2. Signal Generator Settings" on page 3 with the following settings:
 - a. Frequency = 97.968 MHz.
 - b. RF level = -47 dBm.
 - c. FM Deviation = 22.5 kHz.
 - d. Set LFGEN frequency = 1 kHz.
7. Start the receiver BER test feature using the DAB_Test_Get_BER_Info property (see the Programming Guide for details).
8. Adjust the generator #2 RF level, VRF1, until the BER reported = $1e-4$.
9. Selectivity (dB) = VRF1 - VRF0.

Note: VRF0 is the RF level of generator #1.

7.2.5. FIC Timing

1. Connect test equipment as shown in Figure 1 on page 2.
2. Configure generator #1 as described in "2.2. Signal Generator Settings" on page 3 with the following settings:
 - a. Frequency = 207.008 MHz.
 - b. Test Vector = BER_NullPattern_test2.eti.
3. Configure DAB interrupt source to trigger on acquisition change (see the Programming Guide, DAB_DIGRAD_Interrupt_Source).
 - a. Reg 0xB000 = 0x0004.
4. Enable the interrupt property to issue interrupt based on a digital acquisition interrupt (see the Programming Guide, INT_CTL_Enable).
 - a. Reg 0x0000 = 0x0002.
5. Clear the interrupt due to the change in acquisition (see the Programming Guide, DIGRAD_ACK).
6. Place a probe on SSB signal and a probe on INTb signal.
7. Tune the receiver to 207.008 MHz (see the Programming Guide, DAB_Tune_Freq command).
8. Capture the following timing:
 - a. Capture the last rising edge of SSB after the tuning command is issued (T0).
 - b. Capture the falling edge of the INTb line (T1).
9. Ensemble Acquisition time = T1 – T0.

7.3. Stereo THD

1. Connect test equipment as shown in Figure 2 on page 3.
2. Configure generator #1 DAB Digital Modulation as described in section “2.2. Signal Generator Settings” with the following settings:
 - a. Set carrier frequency = 207.008 MHz.
 - b. Load BER test vector, SilabsEnsembleTones07.eti.
3. Configure the audio analyzer:
 - a. Set Function = THD.
 - b. Set Measurement Mode = All di (all harmonics).
 - c. Fundamental = 1000 Hz Fixed.
 - d. Equalizer = Off.
 - e. Function Settling = Off (for quick measurement) or Average (for accurate measurement).
 - f. Select Unit = %.
4. Tune the receiver to 207.008 MHz (see the Programming Guide, DAB_Tune_Freq command).
5. Acquire a list of digital services (see the Programming Guide, Get_Digital_Service_List command).
6. Start digital service (see the Programming Guide, Start_Digital_Service).
 - a. Digital Service ID = 0x0000C000.
 - b. Component = 0x0000.
7. Disable generator #2.
8. Record THD (%).

7.4. Stereo SNR

1. Connect test equipment as shown in Figure 2 on page 3.
2. Configure generator #1 DAB Digital Modulation as described in section “2.2. Signal Generator Settings” with the following settings:
 - a. Set carrier frequency = 207.008 MHz.
 - b. Load BER test vector, SilabsEnsembleTones07.eti.
3. Configure the audio analyzer:
 - a. Set Function = THD+N / SINAD.
 - b. Set Measurement Mode = NOISE.
 - c. Set Units = dB
 - d. Set Filter = A-weighting.
 - e. Set Frequency Limit Low = 300 Hz.
 - f. Set Frequency Limit Upper = 15000 Hz.
 - g. Function Settling = Off (for quick measurement) or Average (for accurate measurement).
4. Tune the receiver to 207.008 MHz (see the Programming Guide, DAB_Tune_Freq command).
5. Acquire a list of digital services (see the Programming Guide, Get_Digital_Service_List command).
6. Start digital service (see the Programming Guide, Start_Digital_Service).
 - a. Digital Service ID = 0x0000C000.
 - b. Component = 0x0000.
7. Record SNR (dB) = Noise (dB).

7.5. Stereo SINAD

1. Connect test equipment as shown in Figure 2 on page 3.
2. Configure generator #1 DAB Digital Modulation as described in section “2.2. Signal Generator Settings” with the following settings:
 - a. Set carrier frequency = 207.008 MHz.
 - b. Load BER test vector, SilabsEnsembleTones07.eti.
3. Configure the audio analyzer:
 - a. Set Function = THD+N / SINAD.
 - b. Set Measurement Mode = SINAD
 - c. Set Units = dB.
 - d. Set Filter = A-weighting.
 - e. Set Frequency Limit Low = 300 Hz.
 - f. Set Frequency Limit Upper = 15000 Hz.
 - g. Set Function Settling = Off (for quick measurement) or Average (for accurate measurement)
4. Record SINAD (dB) = SINAD (dB).

APPENDIX A—PRE-EMPHASIS AND DE-EMPHASIS

A review of FM modulation can be used to understand the effect of pre-emphasis on the spectrum. For a single-tone message,

$$m(t) = A_m \cos(2\pi f_m t) \quad \text{message signal}$$

$$s(t) = A_c \cos(2\pi f_c t) \quad \text{RF carrier}$$

the modulated signal can be represented as

$$\begin{aligned} s(t) &= A_c \cos \left(2\pi f_c t + 2\pi k_f \int_0^t m(t) dt \right) \\ &= A_c \cos \left(2\pi f_c t + \frac{k_f A_m}{f_m} \sin(2\pi f_m t) \right) \end{aligned}$$

with a modulation index, β

$$\beta = \frac{k_f A_m}{f_m} = \frac{\Delta f}{f_m} = \frac{\text{freq deviation}}{\text{modulating freq}} = \text{modulation index}$$

The bandwidth of this signal would be approximately:

$$BW_{s(t)} \approx 2(\Delta f + f_m)$$

The frequency response of a pre-emphasis filter is shown in Figure 6. Depending on the region, a time constant of either 50 or 75 μs is used. This time constant affects the range of frequencies that will be emphasized by the filter. Also, the increase in signal at higher frequencies depends on the time constant of this filter. For a 75 μs filter, 15 kHz would get an increase of 5.3 times relative to 1 kHz, whereas a 50 μs filter would provide an increase on the order of 4.8 times relative to 1 kHz.

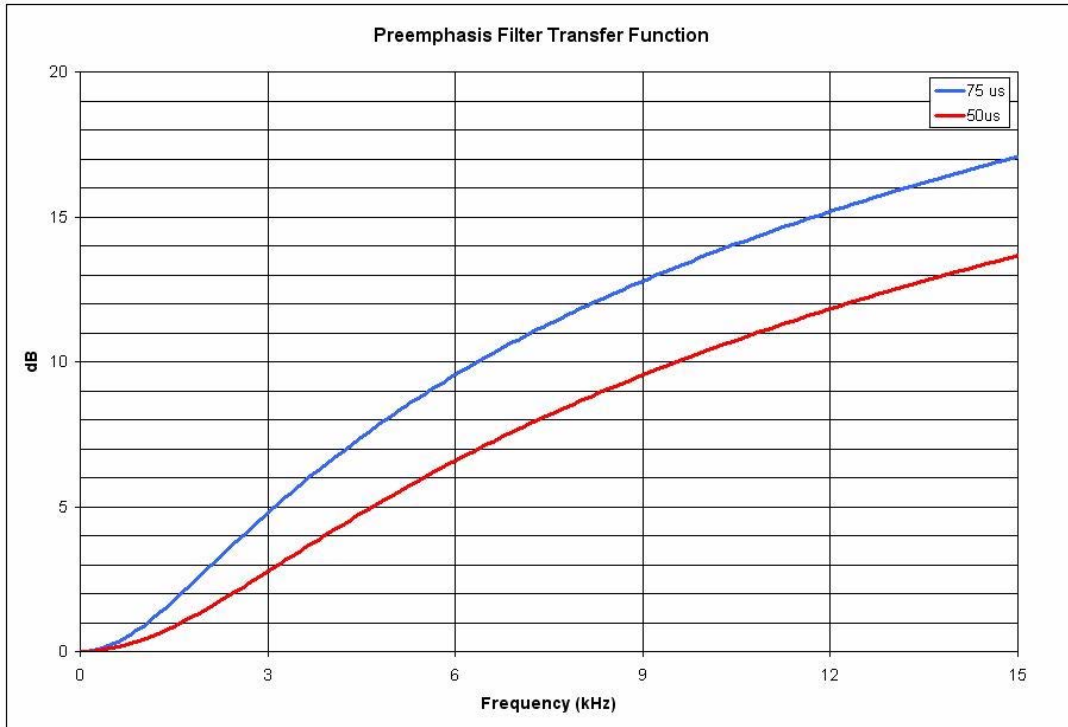

Figure 6. Pre-Emphasis Filter Response

To compensate for the effects of pre-emphasis, the tuner has a de-emphasis filter with low pass characteristics. This filter would need to attenuate higher frequency signals to achieve a flat audio frequency response. Frequency response of an ideal de-emphasis filter for both time constants is shown in Figure 7.

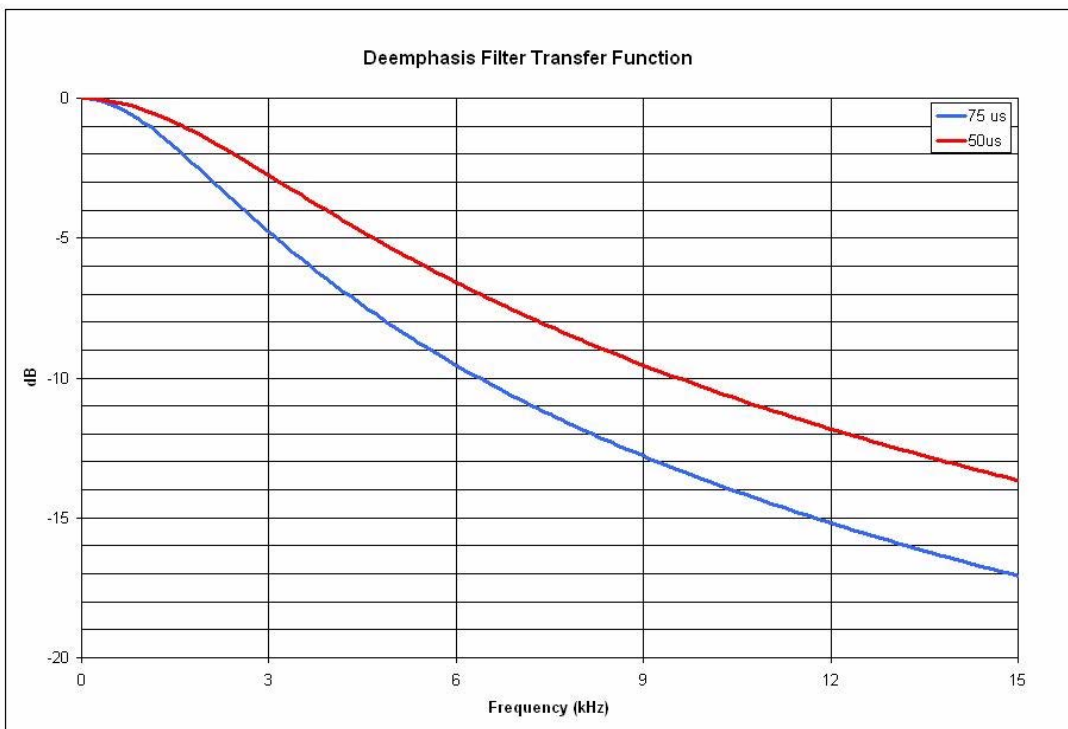
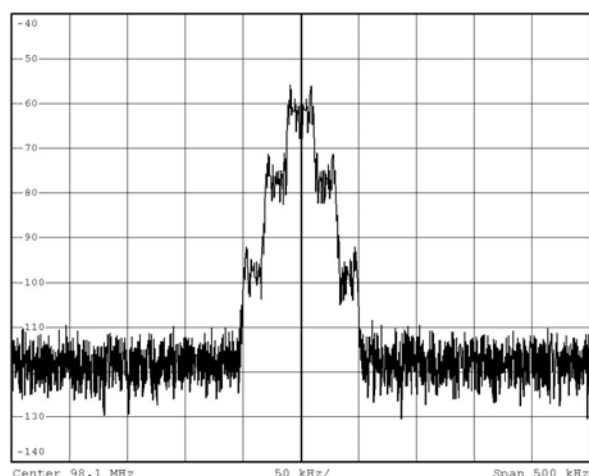

Figure 7. De-Emphasis Filter Response

Figures 8 through 9 are examples of FM spectra with different modulation frequencies and frequency deviations. With low modulation frequencies, applying a pre-emphasis filter has minimum effect on the FM bandwidth since the filter has high-pass characteristics. In Figure 8 and Figure 9, where the modulation frequency is 1 kHz and deviation is 10.5 kHz, you can see that the overall bandwidth does not change with pre-emphasis. The same is true for Figure 12 and Figure 13.

With higher modulation frequencies, the pre-emphasis filter increases the modulating signal amplitude, AM, which translates into a higher FM bandwidth (Figure 10 and Figure 11.) The effect of the pre-emphasis filter combined with higher deviations increases the bandwidth. This increase in the bandwidth is equivalent to having a modulated signal with a frequency deviation higher than the maximum permissible deviation. That is why the deviation should be adjusted when pre-emphasis is applied such that the overall bandwidth is equal to the bandwidth with maximum deviation at 15 kHz modulation frequency.



**Figure 8. RF Frequency = 98.1 MHz,
Frequency Deviation = 10.5 kHz,
Modulation Frequency = 1 kHz,
Pre-emphasis OFF**

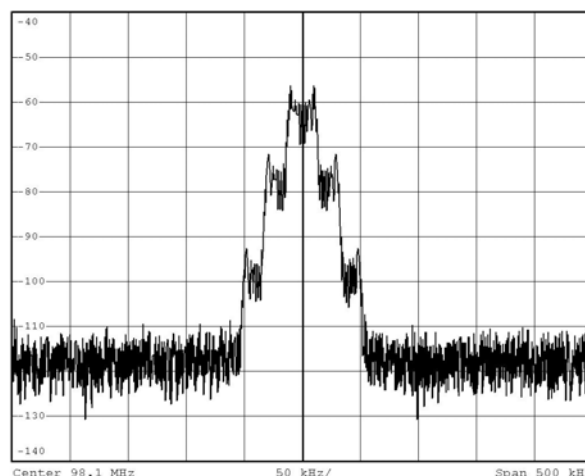

**Figure 9. RF Frequency = 98.1 MHz,
Frequency Deviation = 10.5 kHz,
Modulation Frequency = 1 kHz,
Pre-emphasis = 75 μ s**

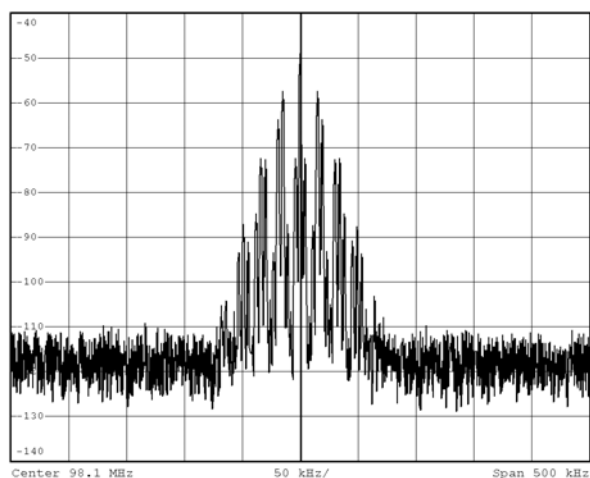

**Figure 10. RF Frequency = 98.1 MHz,
Frequency Deviation = 10.5 kHz,
Modulation Frequency = 15 kHz,
Pre-emphasis OFF**

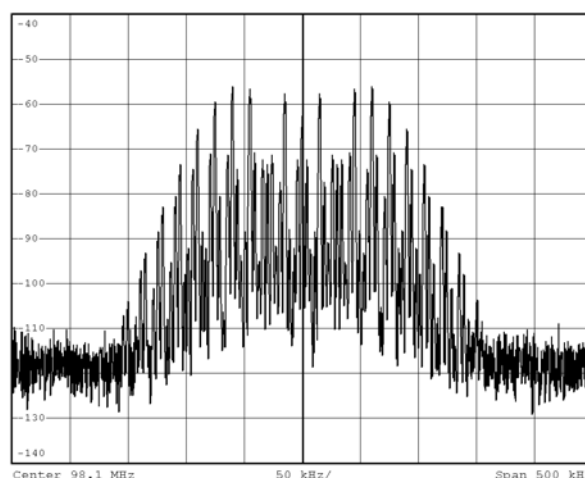

**Figure 11. RF Frequency = 98.1 MHz,
Frequency Deviation = 10.5 kHz,
Modulation Frequency = 15 kHz,
Pre-emphasis = 75 μ s**

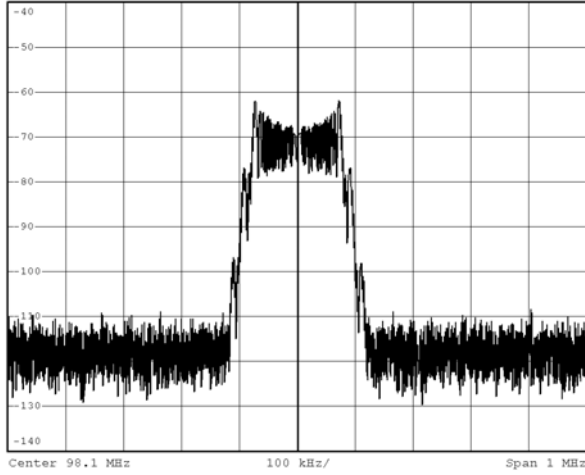

**Figure 12. RF Frequency = 98.1 MHz,
Frequency Deviation = 75 kHz,
Modulation Frequency = 1 kHz,
Pre-emphasis OFF**

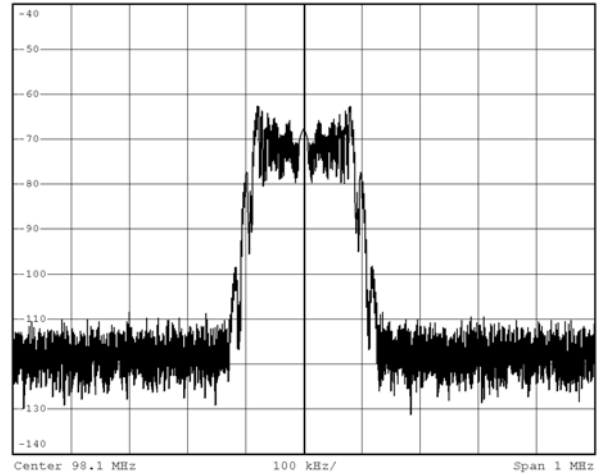

**Figure 13. RF Frequency = 98.1 MHz,
Frequency Deviation = 75 kHz,
Modulation Frequency = 1 kHz,
Pre-emphasis = 75 µs**

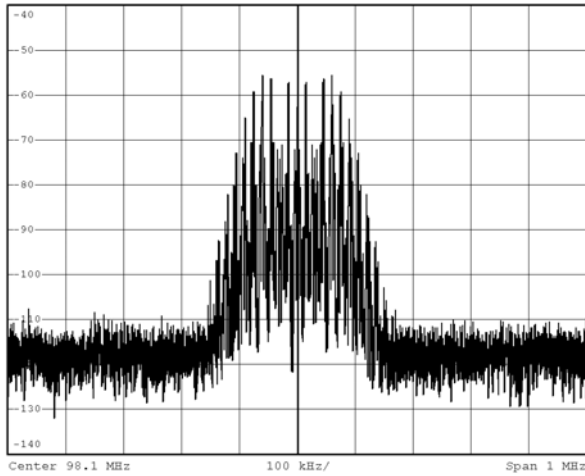

**Figure 14. RF Frequency = 98.1 MHz,
Frequency Deviation = 75 kHz,
Modulation Frequency = 15 kHz,
Pre-emphasis OFF**

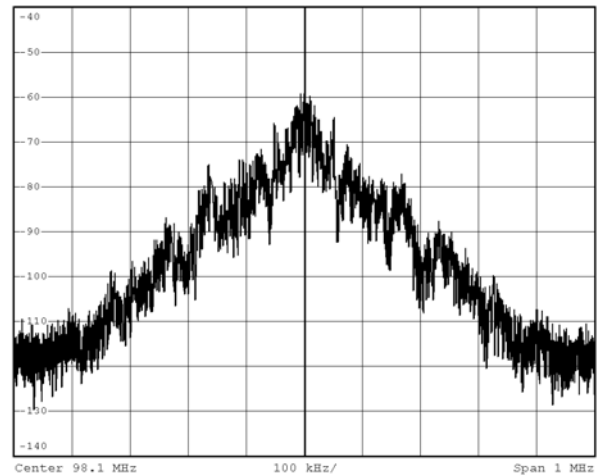

**Figure 15. RF Frequency = 98.1 MHz,
Frequency Deviation = 75 kHz,
Modulation Frequency = 15 kHz,
Pre-emphasis = 75 µs**

DOCUMENT CHANGE LIST

Revision 0.1 to Revision 0.2

- Updated tests to reflect P2 release

Revision 0.2 to Revision 0.3

- Changed flow so that Audio and RF tests are together.

Revision 0.3 to Revision 0.4

- Changed "Si46xx" to "Si468x" throughout.

Revision 0.4 to Revision 0.5

- Added "5. AM Analog Radio Testing" on page 37.
- Added step on page 43.
- Added "6. AMHD Radio Testing" on page 44.

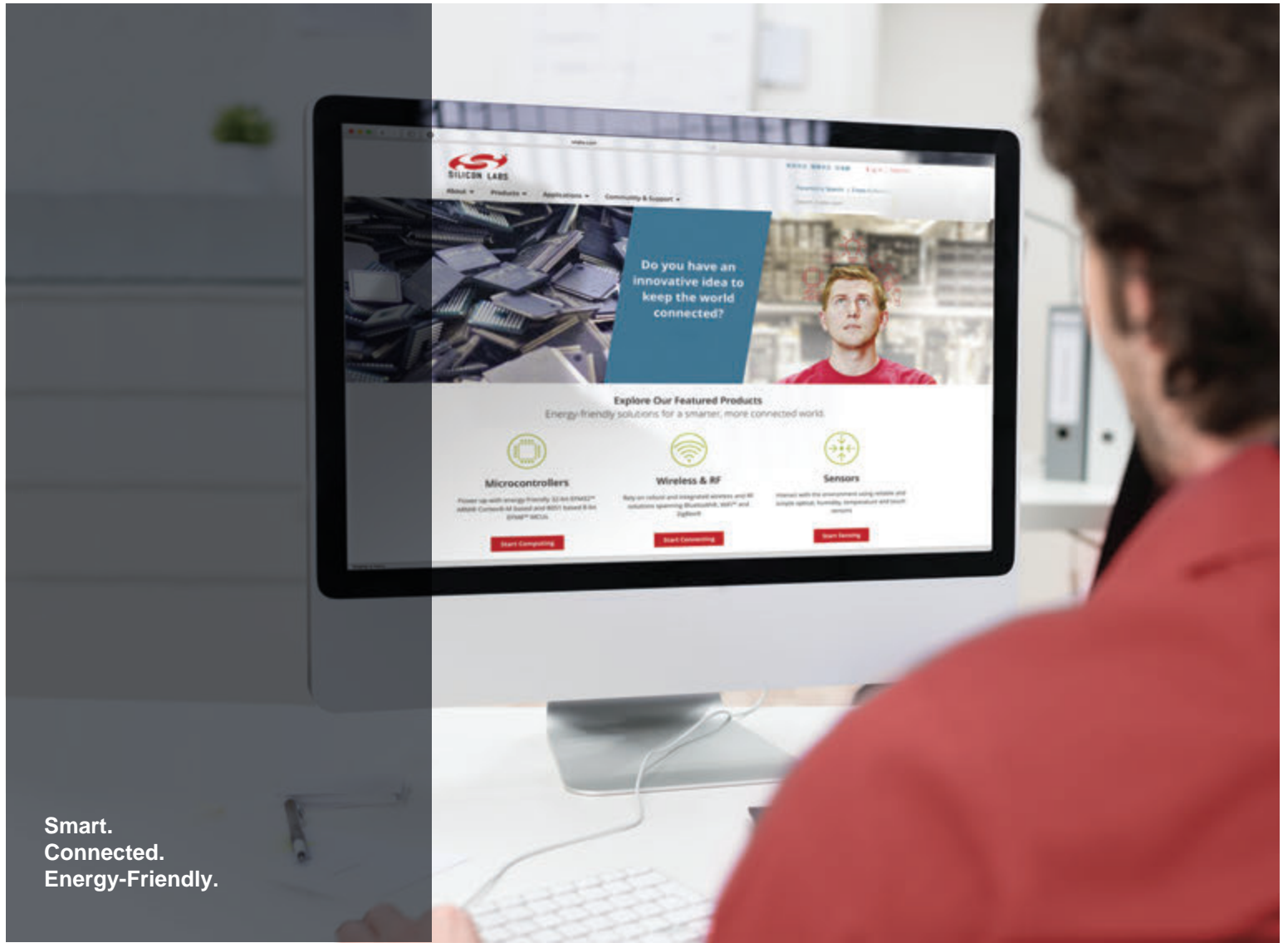

Smart.
Connected.
Energy-Friendly.



Products
www.silabs.com/products

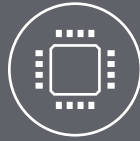

Quality
www.silabs.com/quality



Support and Community
community.silabs.com

Disclaimer
Silicon Labs intends to provide customers with the latest, accurate, and in-depth documentation of all peripherals and modules available for system and software implementers using or intending to use the Silicon Labs products. Characterization data, available modules and peripherals, memory sizes and memory addresses refer to each specific device, and "Typical" parameters provided can and do vary in different applications. Application examples described herein are for illustrative purposes only. Silicon Labs reserves the right to make changes without further notice and limitation to product information, specifications, and descriptions herein, and does not give warranties as to the accuracy or completeness of the included information. Silicon Labs shall have no liability for the consequences of use of the information supplied herein. This document does not imply or express copyright licenses granted hereunder to design or fabricate any integrated circuits. The products are not designed or authorized to be used within any Life Support System without the specific written consent of Silicon Labs. A "Life Support System" is any product or system intended to support or sustain life and/or health, which, if it fails, can be reasonably expected to result in significant personal injury or death. Silicon Labs products are not designed or authorized for military applications. Silicon Labs products shall under no circumstances be used in weapons of mass destruction including (but not limited to) nuclear, biological or chemical weapons, or missiles capable of delivering such weapons.

Trademark Information

Silicon Laboratories Inc.®, Silicon Laboratories®, Silicon Labs®, SiLabs® and the Silicon Labs logo®, Bluegiga®, Bluegiga Logo®, Clockbuilder®, CMEMS®, DSPLL®, EFM®, EFM32®, EFR®, Ember®, Energy Micro, Energy Micro logo and combinations thereof, "the world's most energy friendly microcontrollers", Ember®, EZLink®, EZRadio®, EZRadioPRO®, Gecko®, ISOModem®, Micrium, Precision32®, ProSLIC®, Simplicity Studio®, SiPHY®, Telegesis, the Telegesis Logo®, USBXpress®, Zentri, Z-Wave and others are trademarks or registered trademarks of Silicon Labs. ARM, CORTEX, Cortex-M3 and THUMB are trademarks or registered trademarks of ARM Holdings. Keil is a registered trademark of ARM Limited. All other products or brand names mentioned herein are trademarks of their respective holders.



Silicon Laboratories Inc.
400 West Cesar Chavez
Austin, TX 78701
USA

<http://www.silabs.com>