

GHB-3M50-DR

Features

- ✓ULTRABRIGHTNESS.
- ✓WATER CLEAR LENS.
- ✓OUTSTANDING MATERIAL EFFICIENCY.
- ✓RELIABLE AND RUGGED.
- ✓AC COMPATIBLE/LOW CURRENT CAPABILITY.

Description

The Super Bright Red source color devices are made with Gallium Aluminum Arsenide Red Light Emitting Diode.

T-1 (3mm) SUPER BRIGHT LED LAMP

Package Dimensions

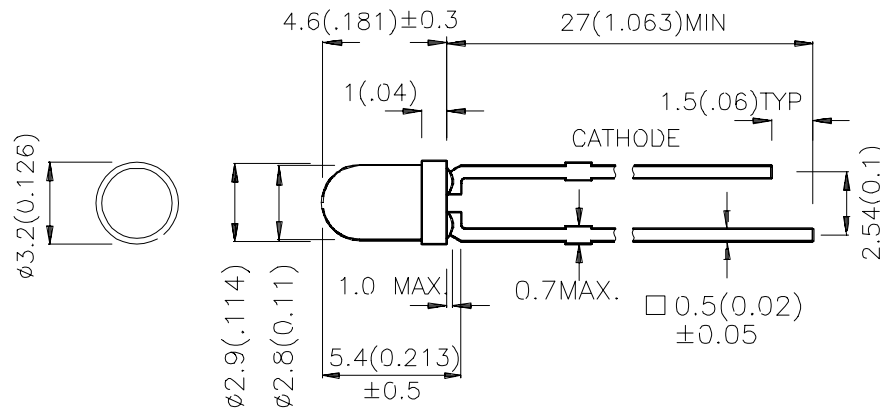

Notes:

1. All dimensions are in millimeters (inches).
2. Tolerance is $.25(0.01)$ unless otherwise noted.
3. Lead spacing is measured where the lead emerge package.
4. Specifications are subject to change without notice.

Optical Characteristics

Part No.	Dice	Lens Type	Iv (mcd) @20mA		Viewing Angle
			Min.	Typ.	
GHB-3M50-DR	SUPER BRIGHT RED (GaAlAs)	WATER CLEAR	1800	2300	50°

Note:

1 1/2 is the angle from optical centerline where the luminous intensity is 1/2 the optical centerline value.

Electrical / Optical Characteristics at T_A=25 C

Symbol	Parameter	Device	Typ.	Max.	Units	Test Conditions
peak	Peak Wavelength	Super Bright Red	660		nm	I _F =20mA
D	Dominate Wavelength	Super Bright Red	640		nm	I _F =20mA
1/2	Spectral Line Half-width	Super Bright Red	20		nm	I _F =20mA
C	Capacitance	Super Bright Red	45		pF	V _F =0V;f=1MHz
V _F	Forward Voltage	Super Bright Red	1.85	2.5	V	I _F =20mA
I _R	Reverse Current	Super Bright Red		10	uA	V _R = 5V

Absolute Maximum Ratings at T_A=25 C

Parameter	Super Bright Red	Units
Power dissipation	100	mW
DC Forward Current	30	mA
Peak Forward Current [1]	155	mA
Reverse Voltage	5	V
Operating/Storage Temperature	-40 C To +85 C	
Lead Solder Temperature [2]	260 C For 5 Seconds	

Notes:

- 1/10 Duty Cycle, 0.1ms Pulse Width.
- 2mm below package base.

