

**PLEASE CHECK WWW.MOLEX.COM FOR LATEST PART INFORMATION**

**Part Number:** [0039310027](#)  
**Status:** **Active**  
**Overview:** [minifit\\_jr](#)  
**Description:** 4.20mm (.165") Pitch Mini-Fit Jr.™ Header, Dual Row, Vertical, without Snap-in Plastic Peg PCB Lock, 2 Circuits, PA Polyamide Nylon 6/6 94V-2, 0.76µm (30µ") Gold (Au) Selective Plating, with Drain Holes

**Documents:**

[3D Model](#)  
[Drawing \(PDF\)](#)

[RoHS Certificate of Compliance \(PDF\)](#)

**Agency Certification**

CSA	LR19980
TUV	R72081037
UL	E29179

**General**

Product Family	PCB Headers
Series	<a href="#">5566</a>
Application	Wire-to-Board
Comments	Current = 13A max. per circuit when header is mated to a receptacle loaded with <a href="#">45750</a> Mini-Fit Plus HCS™ Crimp Terminal Crimped to to 16 AWG wire. . See Molex product specification PS-45750-001 for additional current de-rating information.. High Temperature, Square Pin, Solder Type
Overview	<a href="#">minifit_jr</a>
Product Name	Mini-Fit Jr.™

**Physical**

Breakaway	No
Circuits (Loaded)	2
Circuits (maximum)	2
Color - Resin	Natural
Durability (mating cycles max)	30
First Mate / Last Break	No
Flammability	94V-2
Glow-Wire Compliant	No
Guide to Mating Part	No
Keying to Mating Part	None
Lock to Mating Part	Yes
Material - Metal	Brass
Material - Plating Mating	Gold
Material - Plating Termination	Tin
Material - Resin	Nylon
Number of Rows	2
Orientation	Vertical
PC Tail Length (in)	0.138 In
PC Tail Length (mm)	3.50 mm
PCB Locator	Yes
PCB Retention	None
PCB Thickness Recommended (in)	0.062 In
PCB Thickness Recommended (mm)	1.60 mm
Packaging Type	Bag
Pitch - Mating Interface (in)	0.165 In
Pitch - Mating Interface (mm)	4.20 mm

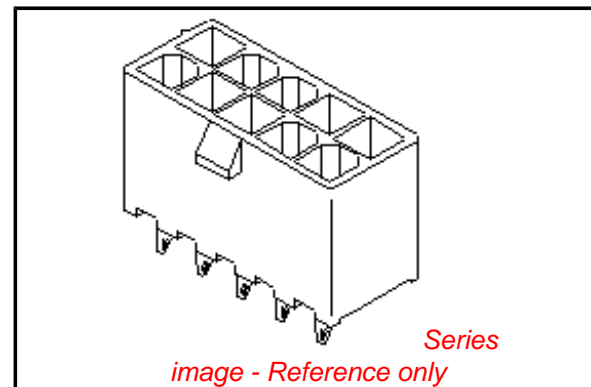

**EU RoHS**

**ELV and RoHS Compliant**  
**REACH SVHC Contains SVHC: No**  
**Halogen-Free Status**

**China RoHS**



**Need more information on product environmental compliance?**

Email [productcompliance@molex.com](mailto:productcompliance@molex.com)  
 For a multiple part number RoHS Certificate of Compliance, [click here](#)

Please visit the [Contact Us](#) section for any non-product compliance questions.

**Search Parts in this Series**

[5566Series](#)

**Mates With**

[5557](#) Mini-Fit Jr.™ Receptacle Housing

Pitch - Term. Interface (in)	0.165 In
Pitch - Term. Interface (mm)	4.20 mm
Polarized to Mating Part	Yes
Polarized to PCB	Yes
Shrouded	Fully
Stackable	No
Surface Mount Compatible (SMC)	No
Temperature Range - Operating	-40°C to +105°C
Termination Interface: Style	Through Hole

**Electrical**

Current - Maximum per Contact	13A
Voltage - Maximum	600V

**Material Info**

Old Part Number	5566-02BGS
-----------------	------------

**Reference - Drawing Numbers**

Sales Drawing	SD-5566-002
---------------	-------------

This document was generated on 05/21/2010

**PLEASE CHECK [WWW.MOLEX.COM](http://WWW.MOLEX.COM) FOR LATEST PART INFORMATION**

CIRCUIT SIZE	DIM. "A"	DIM. "B"
2	.21 (5.4)	—
4	.38 (9.6)	.17 (4.2)
6	.54 (13.8)	.33 (8.4)
8	.71 (18.0)	.50 (12.6)
10	.87 (22.2)	.66 (16.8)
12	1.04 (26.4)	.83 (21.0)
14	1.20 (30.6)	.99 (25.2)
16	1.37 (34.8)	1.16 (29.4)
18	1.54 (39.0)	1.32 (33.6)
20	1.70 (43.2)	1.49 (37.8)
22	1.87 (47.4)	1.65 (42.0)
24	2.03 (51.6)	1.82 (46.2)

**LEGEND**

BASE NUMBER 5566 - N \* \* \* \* - \* - \*

CIRCUIT SIZE \_\_\_\_\_

ASS'Y TYPE \_\_\_\_\_

A : WITHOUT DRAIN HOLES  
B : WITH DRAIN HOLES

TERMINAL MATERIAL \_\_\_\_\_  
SEE NOTE 1

TERMINAL PLATING \_\_\_\_\_  
SEE NOTE 2

HOUSING MATERIAL \_\_\_\_\_  
SEE NOTE 1

COLOR OR PACKAGING \_\_\_\_\_

BL : BLACK RE : RED GR : GRAY  
BU : BLUE YE : YELLOW GRE : GREEN  
TA : TRAY PACKAGING SEE NOTE 4

**NOTES:**

- MATERIALS:  
HOUSING:  
"BLANK"=NYLON 6/6, UL94V-2, COLOR: NATURAL  
"210"=NYLON 6/6, UL94V-0, COLOR: NATURAL  
"400"=NYLON 6/6, UL94V-0, COLOR: BLACK  
TERMINALS:  
"BLANK" = BRASS  
"PB" = PHOSPHOR BRONZE
- TERMINAL PLATING:  
"BLANK" = BRIGHT TIN 000035/(0.00090) MIN.  
OVER COPPER .000020/(0.00050) MIN. (BRASS)  
TIN .000035/(0.00090) MIN. REFLOW TREATMENT  
OR BRIGHT TIN .000035/(0.00090) MIN. (PHOSPHOR BRONZE)  
"S"=.000100/(0.00254) MIN. BRIGHT TIN OVER  
.000050/(0.00127) MIN NICKEL  
"GS2"=.000015/(0.00038) MIN. SELECT GOLD AND  
.000100/(0.00254) MIN. SELECT MATTE TIN  
OVER .000050/(0.00127) MIN. NICKEL OVERALL  
"GS"=.000030/(0.00076) MIN. SELECT GOLD AND  
.000100/(0.00254) MIN. SELECT MATTE TIN  
OVER .000050/(0.00127) MIN. NICKEL OVERALL
- PRODUCT SPECIFICATION: PS-5556-001
- PACKAGING: "BLANK"= BULK PACKED, "TA"=TRAY PACK PER PK-5566-001
- PART MATES WITH MINI-FIT JR. RECEPTACLE NO. 5557.
- PART IS NOT DESIGNED FOR CURRENT SHARING.
- PARTS ARE NOT DESIGNED TO BE MATED OR UN-MATED WHILE CIRCUITS ARE LIVE.
- ANTI-SHINGLING RIB MAY OR MAY NOT APPEAR ON HOUSINGS.
- PART CONFORMS TO CLASS "B" REQUIREMENTS OF COSMETIC SPECIFICATION PS-45499-002.

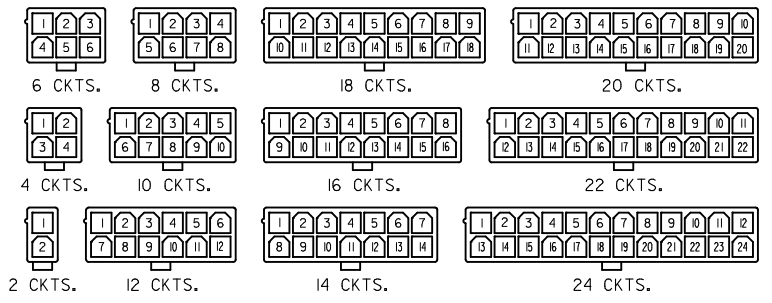
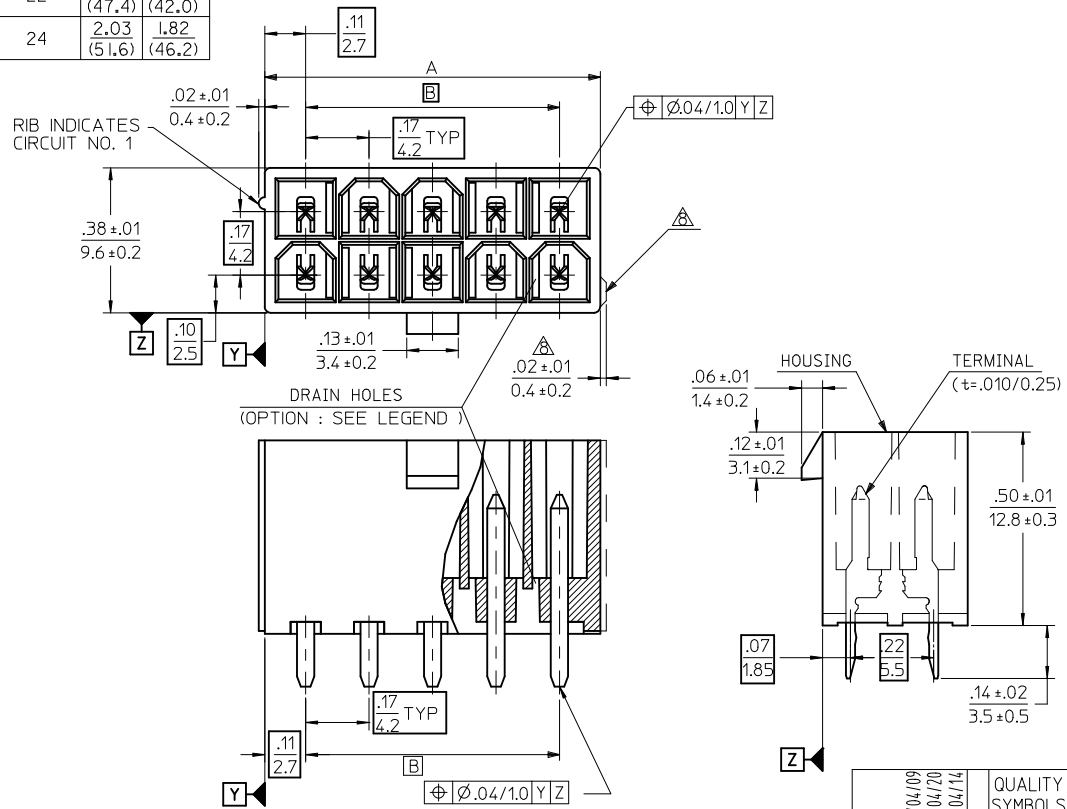

**CIRCUIT SIZE LAYOUT**

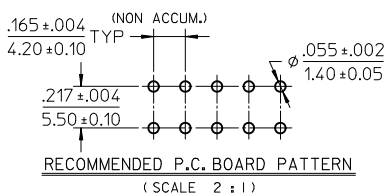

CORRECTED PN EC NO: UCP2010-2614 DRWNG: JAGUILAR 2010/04/09 CHKD: J.BELL '94/04/20 APPR: FSMITH 2010/04/14 REV L3	QUALITY SYMBOLS	GENERAL TOLERANCES (UNLESS SPECIFIED)	DIMENSION STYLE IN/MM	SCALE 4:1	DESIGN UNITS METRIC	THIRD ANGLE PROJECTION
	▽=0	mm INCH	DRAWN BY DATE H.HIRAMOTO '89/04/03	TITLE NEW MINI FIT CONNECTOR HEADER HOUSING ASS'Y -LEAD FREE-	<b>MOLEX INCORPORATED</b>	SHEET NO. 1 OF 6
	▽=0	4 PLACES ± --- ± ---	CHECKED BY DATE M.FUKUSHIMA '94/04/20	DOCUMENT NO. SD-5566-002		
	▽=0	3 PLACES ± --- ± .005	2 PLACES ± .13 ± .010	APPROVED BY DATE M.FUKUSHIMA '94/04/20	THIS DRAWING CONTAINS INFORMATION THAT IS PROPRIETARY TO MOLEX INCORPORATED AND SHOULD NOT BE USED WITHOUT WRITTEN PERMISSION	

	10	9	8	7	6	5	4	3	2	1	
F	39-30-9247	5566-24BGS2-2 I0	39-31-0248	5566-24BGS-2 I0	39-31-0242	5566-24BS-2 I0	39-31-0240	5566-24B-2 I0	39-30-6244	5566-24APBS-2 I0	24
	▲ -9227	▲ -22BGS2-2 I0	▲ -0228	▲ -22BGS-2 I0	▲ -0222	▲ -22BS-2 I0	▲ -0220	▲ -22B-2 I0	▲ -6224	▲ -22APBS-2 I0	22
	-9207	-20BGS2-2 I0	-0208	-20BGS-2 I0	-0202	-20BS-2 I0	-0200	-20B-2 I0	-6204	-20APBS-2 I0	20
	-9187	-18BGS2-2 I0	-0188	-18BGS-2 I0	-0182	-18BS-2 I0	-0180	-18B-2 I0	-6184	-18APBS-2 I0	18
	-9167	-16BGS2-2 I0	-0168	-16BGS-2 I0	-0162	-16BS-2 I0	-0160	-16B-2 I0	-6164	-16APBS-2 I0	16
	-9147	-14BGS2-2 I0	-0148	-14BGS-2 I0	-0142	-14BS-2 I0	-0140	-14B-2 I0	-6144	-14APBS-2 I0	14
	-9127	-12BGS2-2 I0	-0128	-12BGS-2 I0	-0122	-12BS-2 I0	-0120	-12B-2 I0	-6124	-12APBS-2 I0	12
	-9107	-10BGS2-2 I0	-0108	-10BGS-2 I0	-0102	-10BS-2 I0	-0100	-10B-2 I0	-6104	-10APBS-2 I0	10
	-9087	-08BGS2-2 I0	-0088	-08BGS-2 I0	-0082	-08BS-2 I0	-0080	-08B-2 I0	-6084	-08APBS-2 I0	8
	-9067	-06BGS2-2 I0	-0068	-06BGS-2 I0	-0062	-06BS-2 I0	-0060	-06B-2 I0	-6064	-06APBS-2 I0	6
▼ -9047	▼ -04BGS2-2 I0	▼ -0048	▼ -04BGS-2 I0	▼ -0042	▼ -04BS-2 I0	▼ -0040	▼ -04B-2 I0	▼ -6044	▼ -04APBS-2 I0	4	
39-30-9027	5566-02BGS2-2 I0	39-31-0028	5566-02BGS-2 I0	39-31-0022	5566-02BS-2 I0	39-31-0020	5566-02B-2 I0	39-30-6024	5566-02APBS-2 I0	2	
EDP NO.	ENG. NO.	EDP NO.	ENG. NO.	EDP NO.	ENG. NO.	EDP NO.	ENG. NO.	EDP NO.	ENG. NO.	CKT. SIZE	
5566-NBGS2-2 I0		5566-NBGS-2 I0		5566-NBS-2 I0		5566-NB-2 I0		5566-NAPBS-2 I0			
39-30-9246	5566-24BGS2	39-31-0247	5566-24BGS	39-31-0241	5566-24BS	39-29-3246	5566-24B	39-30-6243	5566-24APBS	24	
▲ -9226	▲ -22BGS2	▲ -0227	▲ -22BGS	▲ -0221	▲ -22BS	▲ -3226	▲ -22B	▲ -6223	▲ -22APBS	22	
-9206	-20BGS2	-0207	-20BGS	-0201	-20BS	-3206	-20B	-6203	-20APBS	20	
-9186	-18BGS2	-0187	-18BGS	-0181	-18BS	-3186	-18B	-6183	-18APBS	18	
-9166	-16BGS2	-0167	-16BGS	-0161	-16BS	-3166	-16B	-6163	-16APBS	16	
-9146	-14BGS2	-0147	-14BGS	-0141	-14BS	-3146	-14B	-6143	-14APBS	14	
-9126	-12BGS2	-0127	-12BGS	-0121	-12BS	-3126	-12B	-6123	-12APBS	12	
-9106	-10BGS2	-0107	-10BGS	-0101	-10BS	-3106	-10B	-6103	-10APBS	10	
-9086	-08BGS2	-0087	-08BGS	-0081	-08BS	-3086	-08B	-6083	-08APBS	8	
-9066	-06BGS2	-0067	-06BGS	-0061	-06BS	-3066	-06B	-6063	-06APBS	6	
▼ -9046	▼ -04BGS2	▼ -0047	▼ -04BGS	▼ -0041	▼ -04BS	▼ -3046	▼ -04B	▼ -6043	▼ -04APBS	4	
39-30-9026	5566-02BGS2	39-31-0027	5566-02BGS	39-31-0021	5566-02BS	39-29-3026	5566-02B	39-30-6023	5566-02APBS	2	
EDP NO.	ENG. NO.	EDP NO.	ENG. NO.	EDP NO.	ENG. NO.	EDP NO.	ENG. NO.	EDP NO.	ENG. NO.	CKT. SIZE	
5566-NBGS2		5566-NBGS		5566-NBS		5566-NB		5566-NAPBS			
	39-31-0245	5566-24BPBS	39-31-0243	5566-24BPB	39-31-0246	5566-24BPBS-2 I0	39-31-0244	5566-24BPB-2 I0	24		
	▲ -0225	▲ -22BPBS	▲ -0223	▲ -22BPB	▲ -0226	▲ -22BPBS-2 I0	▲ -0224	▲ -22BPB-2 I0	22		
	-0205	-20BPBS	-0203	-20BPB	-0206	-20BPBS-2 I0	-0204	-20BPB-2 I0	20		
	-0185	-18BPBS	-0183	-18BPB	-0186	-18BPBS-2 I0	-0184	-18BPB-2 I0	18		
	-0165	-16BPBS	-0163	-16BPB	-0166	-16BPBS-2 I0	-0164	-16BPB-2 I0	16		
	-0145	-14BPBS	-0143	-14BPB	-0146	-14BPBS-2 I0	-0144	-14BPB-2 I0	14		
	-0125	-12BPBS	-0123	-12BPB	-0126	-12BPBS-2 I0	-0124	-12BPB-2 I0	12		
	-0105	-10BPBS	-0103	-10BPB	-0106	-10BPBS-2 I0	-0104	-10BPB-2 I0	10		
	-0085	-08BPBS	-0083	-08BPB	-0086	-08BPBS-2 I0	-0084	-08BPB-2 I0	8		
	-0065	-06BPBS	-0063	-06BPB	-0066	-06BPBS-2 I0	-0064	-06BPB-2 I0	6		
	▼ -0045	▼ -04BPBS	▼ -0043	▼ -04BPB	▼ -0046	▼ -04BPBS-2 I0	▼ -0044	▼ -04BPB-2 I0	4		
	39-31-0025	5566-02BPBS	39-31-0023	5566-02BPB	39-31-0026	5566-02BPBS-2 I0	39-31-0024	5566-02BPB-2 I0	2		
	EDP NO.	ENG. NO	EDP NO.	ENG. NO	EDP NO.	ENG. NO	EDP NO.	ENG. NO	CKT. SIZE		
	5566-NBPBS		5566-NBPB		5566-NBPBS-2 I0		5566-NBPB-2 I0				

PARTS WITH DRAIN HOLES

SEE SHEET 1 EC NO: UCP2010-2614 DRWN: J. AGUILAR 2010/04/09 CHKD: IBELL '94/04/20 APPR: FSM TH 2010/04/14	GENERAL TOLERANCES (UNLESS SPECIFIED)		DIMENSION STYLE IN/MM		SCALE ---	DESIGN UNITS METRIC	THIRD ANGLE PROJECTION
	10 UNDER	± ---	DRAWN BY H. HIRAMOTO	DATE '89/04/03	TITLE NEW MINI FIT CONNECTOR HEADER HOUSING ASS'Y -LEAD FREE-		
	10 OVER 30 UNDER	± ---	CHECKED BY M. FUKUSHIMA	DATE '94/04/20	MOLEX MOLEX INCORPORATED		
	30 OVER	± ---	APPROVED BY M. FUKUSHIMA	DATE '94/04/20	MATERIAL NO. SEE TABLE	DOCUMENT NO. SD-5566-002	SHEET NO. 3 OF 6
ANGULAR ± --- °		DRAFT WHERE APPLICABLE MUST REMAIN WITHIN DIMENSIONS		THIS DRAWING CONTAINS INFORMATION THAT IS PROPRIETARY TO MOLEX INCORPORATED AND SHOULD NOT BE USED WITHOUT WRITTEN PERMISSION			