

Universal Single-chip Clock Solution for VIA P4M266/KM266 DDR Systems

Features

- Supports VIA P4M266/KM266 chipsets
- Supports Pentium® 4, Athlon™ processors
- Supports two DDR DIMMS
- Provides
 - Two different programmable CPU clock pairs
 - Six differential DDR SDRAM pairs
 - Two low-skew/low-jitter AGP clocks
 - Six low-skew/low-jitter PCI clocks
 - One 48M output for USB
 - One programmable 24M or 48M for SIO
- Dial-a-Frequency™ and Dial-a-dB™ features
- Spread Spectrum for best electromagnetic interference (EMI) reduction
- SMBus-compatible for programmability
- 56-pin SSOP and TSSOP packages

Table 1. Frequency Selection Table

| FS(3:0) | CPU | AGP | PCI |
|---------|--------|-------|-------|
| 0000 | 66.80 | 66.80 | 33.40 |
| 0001 | 100.20 | 66.80 | 33.40 |
| 0010 | 120.00 | 60.00 | 30.00 |
| 0011 | 133.33 | 66.67 | 33.33 |
| 0100 | 72.00 | 72.00 | 36.00 |
| 0101 | 105.00 | 70.00 | 35.00 |
| 0110 | 160.00 | 64.00 | 32.00 |
| 0111 | 140.00 | 70.00 | 35.00 |
| 1000 | 77.00 | 77.00 | 38.50 |
| 1001 | 110.00 | 73.33 | 36.67 |
| 1010 | 180.00 | 60.00 | 30.00 |
| 1011 | 150.00 | 60.00 | 30.00 |
| 1100 | 90.00 | 60.00 | 30.00 |
| 1101 | 100.00 | 66.67 | 33.33 |
| 1110 | 200.00 | 66.67 | 33.33 |
| 1111 | 133.33 | 66.67 | 33.33 |

Block Diagram

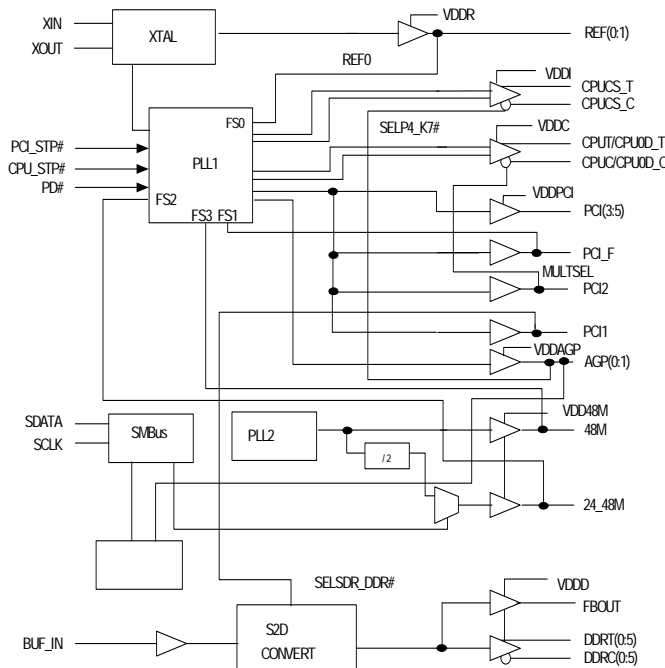

Pin Configuration^[1]

| | | | |
|-----------------|----|----|-----------------|
| *FS0/REF0 | 1 | 56 | VTT/PWRGD#/REF1 |
| VSSR | 2 | 55 | VDDR |
| XIN | 3 | 54 | VSSC |
| XOUT | 4 | 53 | CPUT/CPUOD_T |
| VDDAGP | 5 | 52 | CPUC/CPUOD_C |
| *MODE/AGP0 | 6 | 51 | VDDC |
| *SELP4_K7#/AGP1 | 7 | 50 | VDDI |
| *PCI_STP# | 8 | 49 | CPUCS_C |
| VSSAGP | 9 | 48 | CPUCS_T |
| **FS1/PCLF | 10 | 47 | VSSI |
| PCI1 | 11 | 46 | FBOUT |
| *MULTSEL/PCI2 | 12 | 45 | BUF_IN |
| VSSPCI | 13 | 44 | DDRT0 |
| PCI3 | 14 | 43 | DDRC0 |
| PCI4 | 15 | 42 | DDRT1 |
| VDDPCI | 16 | 41 | DDRC1 |
| PCI5 | 17 | 40 | VDDO |
| *CPU_STP# | 18 | 39 | VSSD |
| VSS48M | 19 | 38 | DDRT2 |
| **FS3/48M | 20 | 37 | DDRC2 |
| **FS2/24_48M | 21 | 36 | DDRT3 |
| VDD48M | 22 | 35 | DDRC3 |
| VDD | 23 | 34 | VDDO |
| VSS | 24 | 33 | VSSD |
| IREF | 25 | 32 | DDRT4 |
| *PD# | 26 | 31 | DDRC4 |
| SCLK | 27 | 30 | DDRT5 |
| SDATA | 28 | 29 | DDRC5 |

CY28347

Note:

1. Pins marked with [*] have internal pull-up resistors. Pins marked with [**] have internal pull-down resistors.

Pin Description ^[2]

| Pin | Name | PWR | I/O | Description |
|-----------------------|--------------------|--------|-----------|---|
| 3 | XIN | | I | Oscillator Buffer Input. Connect to a crystal or to an external clock. |
| 4 | XOUT | VDD | O | Oscillator Buffer Output. Connect to a crystal. Do not connect when an external clock is applied at XIN. |
| 1 | FS0/REF0 | VDD | I/O PU | Power-on Bidirectional Input/Output. At power-up, FS0 is the input. When the power supply voltage crosses the input threshold voltage, FS0 state is latched and this pin becomes REF0, buffered copy of signal applied at XIN. (1–2 x strength, selectable by SMBus. Default value is 1 x strength.) |
| 56 | VTPWRGD# | VDDR | I | If SELP4_K7# = 1, with a P4 processor setup as CPU(T:C). At power-up, VTT_PWRGD# is an input. When this input is sampled LOW, the FS (3:0) and MULTSEL are latched and all output clocks are enabled. After the first transition to a LOW on VTT_PWRGD#, this pin is ignored and will not effect the behavior of the device thereafter. When the VTT_PWRGD# feature is not used, please connect this signal to ground through a 10KΩ resistor. |
| | REF1 | VDDR | O | If SELP4_K7# = 0, with an Athlon (K7) processor as CPUOD_(T:C). VTT_PWRGD# function is disabled, and the feature is ignored. This pin becomes REF1 and is a buffered copy of the signal applied at XIN. |
| 44,42,38, 36,32,30 | DDRT(0:5) | VDDD | O | These pins are configured for DDR clock outputs. They are “True” copies of signal applied at Pin45, BUF_IN. |
| 43,41,37 35,31,29 | DDRC(0:5) | VDDD | O | These pins are configured for DDR clock outputs. They are “Complementary” copies of signal applied at Pin45, BUF_IN. |
| 7 | SELP4_K7#/ AGP1 | VDDAGP | I/O PU | Power-on Bidirectional Input/Output. At power-up, SELP4_K7# is the input. When the power supply voltage crosses the input threshold voltage, SELP4_K7# state is latched and this pin becomes AGP1 clock output. SELP4_K7# = 1 selects P4 mode. SELP4_K7# = 0 selects K7 mode. |
| 12 | MULTSEL/PCI2 | VDDPCI | I/O PU | Power-on Bidirectional Input/Output. At power-up, MULTSEL is the input. When the power supply voltage crosses the input threshold voltage, MULTSEL state is latched and this pin becomes PCI2 clock output. MULTSEL = 0, Ioh is 4 x IREFMULTSEL = 1, Ioh is 6 x IREF |
| 53 | CPUT/CPUOD_T | VDDC | O | 3.3V True CPU Clock Outputs. This pin is programmable through strapping pin7, SELP4_K7#. If SELP4_K7# = 1, this pin is configured as the CPUT Clock Output. If SELP4_K7# = 0, this pin is configured as the CPUOD_T Open Drain Clock Output. See <i>Table 1</i> . |
| 52 | CPUC/CPUOD_C | VDDC | O | 3.3V Complementary CPU Clock Outputs. This pin is programmable through strapping pin7, SELP4_K7#. If SELP4_K7# = 1, this pin is configured as the CPUC Clock Output. If SELP4_K7# = 0, this pin is configured as the CPUOD_C Open Drain Clock Output. See <i>Table 1</i> . |
| 14,15,17 | PCI (3:5) | VDDPCI | O | PCI Clock Outputs. Are synchronous to CPU clocks. See <i>Table 1</i> . |
| 48,49 | CPUCS_T/C | VDDI | O | 2.5V CPU Clock Outputs for Chipset. See <i>Table 1</i> . |
| 18 | CPU_STP# | VDDPCI | I PU | If pin 6 is pulled down at power on reset, then this pin becomes CPU_STP#. When CPU_STP# is asserted LOW, then both of the CPU signals stop at the next HIGH to LOW transition or stays LOW if it already is LOW. This does not stop the CPUCS signals. |
| 10 | FS1/PCI_F | VDDPCI | I/O PD | Power-on Bidirectional Input/Output. At power-up, FS1 is the input. When the power supply voltage crosses the input threshold voltage, FS1 state is latched and this pin becomes PCI_F clock output. |
| 20 | FS3/48M | VDD48M | I/O PD | Power-on Bidirectional Input/Output. At power-up, FS3 is the input. When the power supply voltage crosses the input threshold voltage, FS3 state is latched and this pin becomes 48M, a USB clock output. |
| 11 | PCI1 | VDDPCI | O | PCI Clock Output. |
| 21 | FS2/24_48M | VDD48M | I/O PD | Power-on Bidirectional Input/Output. At power-up, FS2 is the input. When the power supply voltage crosses the input threshold voltage, FS2 state is latched and this pin becomes 24_48M, a SIO programmable clock output. |

Note:

2. PU = internal pull-up. PD = internal pull-down. Typically = 250 kΩ (range 200 kΩ to 500 kΩ).

Pin Description (continued)^[2]

| Pin | Name | PWR | I/O | Description |
|-------|-----------|--------|-----------|---|
| 6 | MODE/AGP0 | VDDAGP | I/O PU | Power-on Bidirectional Input/Output. At power-up, MODE is an input and becomes AGP0 output after the power supply voltage crosses the input threshold voltage. Must have 10KΩ resistor to V _{SS} . See <i>Table 2</i> . |
| 8 | PCI_STP# | VDDAGP | I PU | If pin 6 is pulled down at power on reset, then this pin becomes PCI_STP#. When PCI_STP# is asserted LOW, then all of the PCI signals, except the PCI_F, stops at the next HIGH to LOW transition or stays LOW if it already is LOW. |
| 25 | IREF | | I | Current reference programming input for CPU buffers. A precise resistor is attached to this pin, which is connected to the internal current reference. |
| 28 | SDATA | | I/O | Serial Data Input. Conforms to the SMBus specification of a Slave Receive/Transmit device. It is an input when receiving data. It is an open drain output when acknowledging or transmitting data. |
| 27 | SCLK | | I | Serial Clock Input. Conforms to the SMBus specification. |
| 26 | PD# | | I PU | When PD# is asserted LOW, the device enters power down mode. See power management function. |
| 45 | BUF_IN | | I | 2.5V CMOS type input to the DDR differential buffers. |
| 46 | FBOUT | | O | This is the single-ended, SDRAM buffered output of the signal applied at BUF_IN. It is in phase with the DDRT(0:5) signals. |
| 5 | VDDAGP | | | 3.3V power supply for AGP clocks. |
| 51 | VDDC | | | 3.3V power supply for CPU (T: C) clocks. |
| 16 | VDDPCI | | | 3.3V power supply for PCI clocks. |
| 55 | VDDR | | | 3.3V power supply for REF clock. |
| 50 | VDDI | | | 2.5V power supply for CPUCS_T/C clocks. |
| 22 | VDD48M | | | 3.3V power supply for 48M. |
| 23 | VDD | | | 3.3V Common power supply. |
| 34,40 | VDDD | | | 2.5V power supply for DDR clocks. |
| 9 | VSSAGP | | | Ground for AGP clocks. |
| 13 | VSSPCI | | | Ground for PCI clocks. |
| 54 | VSSC | | | Ground for CPU (T:C) clocks. |
| 33,39 | VSSD | | | Ground for DDR clocks. |
| 19 | VSS48M | | | Ground for 48M clock. |
| 47 | VSSI | | | Ground for CPUCS_T/C clocks. |
| 24 | VSS | | | Common ground. |

Table 2. MODE Pin-Power Management Input Control

| MODE, Pin 6 (Latched Input) | Pin 26 | Pin 18 | Pin 8 |
|--------------------------------|----------|----------|----------|
| 0 | PD# | CPU_STP# | PCI_STP# |
| Invalid | Reserved | Reserved | Reserved |

Table 3. Swing Select Functions Through Hardware

| MULTSEL | Board Target Trace/Term Z | Reference R, IREF = VDD/(3*Rr) | Output Current | VOH@Z |
|---------|------------------------------|-----------------------------------|----------------|---------|
| 0 | 50 Ohm | Rr = 221 1%, IREF = 5.00 mA | IOH = 4* Iref | 1.0V@50 |
| 1 | 50 Ohm | Rr = 475 1%, IREF = 2.32 mA | IOH = 6* Iref | 0.7V@50 |

Serial Data Interface

To enhance the flexibility and function of the clock synthesizer, a two-signal serial interface is provided. Through the Serial Data Interface, various device functions such as individual clock output buffers, etc., can be individually enabled or disabled.

The registers associated with the Serial Data Interface initializes to their default setting upon power-up, and therefore use of this interface is optional. Clock device register changes are normally made upon system initialization, if any are required. The interface can also be used during system operation for power management functions.

Data Protocol

The clock driver serial protocol accepts Byte Write, Byte Read, Block Write, and Block Read operation from the controller. For Block Write/Read operation, the bytes must be accessed in sequential order from lowest to highest byte (most significant bit first) with the ability to stop after any complete byte has been transferred. For Byte Write and Byte Read operations, the system controller can access individual indexed bytes. The offset of the indexed byte is encoded in the command code, as described in *Table 4*.

The Block Write and Block Read protocol is outlined in *Table 5* while *Table 6* outlines the corresponding Byte Write and Byte Read protocol. The slave receiver address is 11010010 (D2H).

Table 4. Command Code Definition

| Bit | Description |
|-------|---|
| 7 | 0 = Block Read or Block Write operation 1 = Byte Read or Byte Write operation |
| (6:0) | Byte offset for Byte Read or Byte Write operation. For Block Read or Block Write operations, these bits should be "0000000" |

Table 5. Block Read and Block Write Protocol

| Block Write Protocol | | Block Read Protocol | |
|----------------------|--|---------------------|--|
| Bit | Description | Bit | Description |
| 1 | Start | 1 | Start |
| 2:8 | Slave address - 7 bits | 2:8 | Slave address - 7 bits |
| 9 | Write | 9 | Write |
| 10 | Acknowledge from slave | 10 | Acknowledge from slave |
| 11:18 | Command Code - 8 Bit "00000000" stands for block operation | 11:18 | Command Code - 8 Bit "00000000" stands for block operation |
| 19 | Acknowledge from slave | 19 | Acknowledge from slave |
| 20:27 | Byte Count - 8 bits | 20 | Repeat start |
| 28 | Acknowledge from slave | 21:27 | Slave address - 7 bits |
| 29:36 | Data byte 0 - 8 bits | 28 | Read |
| 37 | Acknowledge from slave | 29 | Acknowledge from slave |
| 38:45 | Data byte 1 - 8 bits | 30:37 | Byte count from slave - 8 bits |
| 46 | Acknowledge from slave | 38 | Acknowledge |
| | Data Byte N/Slave Acknowledge... | 39:46 | Data byte from slave - 8 bits |
| | Data Byte N - 8 bits | 47 | Acknowledge |
| | Acknowledge from slave | 48:55 | Data byte from slave - 8 bits |
| | Stop | 56 | Acknowledge |
| | | | Data bytes from slave/Acknowledge |
| | | | Data byte N from slave - 8 bits |
| | | | Not Acknowledge |
| | | | Stop |

Table 6. Byte Read and Byte Write Protocol

| Byte Write Protocol | | Byte Read Protocol | |
|---------------------|------------------------|--------------------|------------------------|
| Bit | Description | Bit | Description |
| 1 | Start | 1 | Start |
| 2:8 | Slave address - 7 bits | 2:8 | Slave address - 7 bits |
| 9 | Write | 9 | Write |

Table 6. Byte Read and Byte Write Protocol (continued)

| | | | |
|-------|---|-------|---|
| 10 | Acknowledge from slave | 10 | Acknowledge from slave |
| 11:18 | Command Code - 8 bits "1xxxxxx" stands for byte operation bit[6:0] of the command code represents the offset of the byte to be accessed | 11:18 | Command Code - 8 bits "1xxxxxx" stands for byte operation bit[6:0] of the command code represents the offset of the byte to be accessed |
| 19 | Acknowledge from slave | 19 | Acknowledge from slave |
| 20:27 | Data Byte from Master – 8 Bits | 20 | Repeat start |
| 28 | Acknowledge from slave | 21:27 | Slave address - 7 bits |
| 29 | Stop | 28 | Read |
| | | 29 | Acknowledge from slave |
| | | 30:37 | Data byte from slave - 8 bits |
| | | 38 | Not Acknowledge |
| | | 39 | Stop |

Byte 0: Frequency Select Register

| Bit | @Pup | Pin# | Name | Description |
|-----|-------------|------|-----------|--|
| 7 | 0 | | | Reserved. |
| 6 | H/W Setting | 21 | FS2 | For Selecting Frequencies see <i>Table 1</i> . |
| 5 | H/W Setting | 10 | FS1 | For Selecting Frequencies see <i>Table 1</i> . |
| 4 | H/W Setting | 1 | FS0 | For Selecting Frequencies see <i>Table 1</i> . |
| 3 | 0 | | | If this bit is programmed to "1," it enables WRITES to bits (6:4,1) for selecting the frequency via software (SMBus) If this bit is programmed to a "0" it enables only READS of bits (6:4,1), which reflect the hardware setting of FS(0:3). |
| 2 | H/W Setting | 11 | Reserved | Reserved |
| 1 | H/W Setting | 20 | FS3 | For Selecting frequencies in <i>Table 1</i> . |
| 0 | H/W Setting | 7 | SELP4_K7# | Only for reading the hardware setting of the CPU interface mode, status of SELP4_K7# strapping. |

Byte 1: CPU Clocks Register

| Bit | @Pup | Pin# | Name | Description |
|-----|------|-------|-----------------|--|
| 7 | 0 | | SSMODE | 0 = Down Spread. 1 = Center Spread. See <i>Table 10</i> . |
| 6 | 1 | | SSCG | 1 = Enable (default). 0 = Disable |
| 5 | 1 | | SST1 | Select spread bandwidth. See <i>Table 10</i> . |
| 4 | 1 | | SST0 | Select spread bandwidth. See <i>Table 10</i> . |
| 3 | 1 | 48,49 | CPUCS_T/C_EN# | 1 = output enabled (running). 0 = output disabled asynchronously in a LOW state. |
| 2 | 1 | 53,52 | CPUOD_T/C_EN# | 1 = output enabled (running). 0 = output disable asynchronously in a LOW state. |
| 1 | 0 | 53,52 | CPUT/C_PD_CNTRL | In K7 mode, this bit is ignored. In P4 mode, when PD# asserted LOW, 0 = drive CPUT to 2xIref and CPUC LOW and 1 = three-state CPUT and CPUC. |
| 0 | 1 | 11 | MULT0 | Only For reading the hardware setting of the Pin11 MULT0 value. |

Byte 2: PCI Clock Register

| Bit | @Pup | Pin# | Name | Description |
|-----|------|------|---------|--|
| 7 | 0 | | PCI_DRV | PCI clock output drive strength 0 = Normal, 1 = increase the drive strength 20%. |
| 6 | 1 | 10 | PCI_F | 1 = output enabled (running). 0 = output disabled asynchronously in a LOW state. |
| 5 | 1 | | | Reserved, set = 1. |

Byte 2: PCI Clock Register (continued)

| Bit | @Pup | Pin# | Name | Description |
|-----|------|------|------|--|
| 4 | 1 | 17 | PCI5 | 1 = output enabled (running). 0 = output disabled asynchronously in a LOW state. |
| 3 | 1 | 15 | PCI4 | 1 = output enabled (running). 0 = output disabled asynchronously in a LOW state. |
| 2 | 1 | 14 | PCI3 | 1 = output enabled (running). 0 = output disabled asynchronously in a LOW state. |
| 1 | 1 | 12 | PCI2 | 1 = output enabled (running). 0 = output disabled asynchronously in a LOW state. |
| 0 | 1 | 11 | PCI1 | 1 = output enabled (running). 0 = output disabled asynchronously in a LOW state. |

Byte 3: AGP/Peripheral Clocks Register

| Bit | @Pup | Pin# | Name | Description |
|-----|------|-------|--------|---|
| 7 | 0 | 21 | 24_48M | "0" = pin 21 output is 24 MHz. Writing a "1" into this register asynchronously changes the frequency at pin 21 to 48 MHz. |
| 6 | 1 | 20 | 48MHz | 1 = output enabled (running). 0 = output disabled asynchronously in a LOW state. |
| 5 | 1 | 21 | 24_48M | 1 = output enabled (running). 0 = output disabled asynchronously in a LOW state. |
| 4 | 0 | 6,7,8 | DASAG1 | Programming these bits allow shifting skew of the AGP(0:2) signals relative to their default value. See <i>Table 7</i> . |
| 3 | 0 | 6,7,8 | DASAG0 | |
| 2 | 1 | | | Reserved, set = 1. |
| 1 | 1 | 7 | AGP1 | 1 = output enabled (running). 0 = output disabled asynchronously in a LOW state. |
| 0 | 1 | 6 | AGP0 | 1 = output enabled (running). 0 = output disabled asynchronously in a LOW state. |

Byte 4: Peripheral Clocks Register

| Bit | @Pup | Pin# | Name | Description |
|-----|------|-------|--------|---|
| 7 | 1 | 20 | 48M | 1 = strength x 1. 0 = strength x 2 1 = strength x 1. 0 = strength x 2 |
| 6 | 1 | 21 | 24_48M | 1 = strength x 1. 0 = strength x 2 1 = strength x 1. 0 = strength x 2 |
| 5 | 0 | 6,7,8 | DARAG1 | Programming these bits allow modifying the frequency ratio of the AGP(2:0), PCI(6:1, F) clocks relative to the CPU clocks. See <i>Table 8</i> . |
| 4 | 0 | 6,7,8 | DARAG0 | |
| 3 | 1 | 1 | REF0 | 1 = output enabled (running). 0 = output disabled asynchronously in a LOW state. |
| 2 | 1 | 56 | REF1 | 1 = output enabled (running). 0 = output disabled asynchronously in a LOW state. (K7 Mode only.) |
| 1 | 1 | 1 | REF0 | 1 = strength x 1. 0 = strength x 2 |
| 0 | 1 | 56 | REF1 | 1 = strength x 1. 0 = strength x 2 (K7 Mode only) |

Table 7. Dial-a-Skew™ AGP(0:2)

| DASAG (1:0) | AGP(0:2) Skew Shift |
|-------------|---------------------|
| 00 | Default |
| 01 | -280 ps |
| 10 | +280 ps |
| 11 | +480 ps |

Table 8. Dial-A-Ratio™ AGP(0:2)

| DARAG (1:0) | CU/AGP Ratio |
|-------------|-----------------------------|
| 00 | Frequency Selection Default |
| 01 | 2/1 |
| 10 | 2.5/1 |
| 11 | 3/1 |

Byte 5: DDR Clock Register

| Bit | @Pup | Pin# | Name | Description |
|-----|------|-------|--------------------------|--|
| 7 | 0 | 45 | BUF_IN threshold voltage | DDR Mode, BUF_IN threshold setting. 0 = 1.15V, 1 = 1.05V. |
| 6 | 1 | 46 | FBOUT | 1 = output enabled (running). 0 = output disabled asynchronously in a LOW state. |
| 5 | 1 | 29,30 | DDRT/C5 | 1 = output enabled (running). 0 = output disabled asynchronously in a LOW state. |
| 4 | 1 | 31,32 | DDRT/C4 | 1 = output enabled (running). 0 = output disabled asynchronously in a LOW state. |
| 3 | 1 | 35,36 | DDRT/C3 | 1 = output enabled (running). 0 = output disabled asynchronously in a LOW state. |
| 2 | 1 | 37,38 | DDRT/C2 | 1 = output enabled (running). 0 = output disabled asynchronously in a LOW state. |
| 1 | 1 | 41,42 | DDRT/C1 | 1 = output enabled (running). 0 = output disabled asynchronously in a LOW state. |
| 0 | 1 | 43,44 | DDRT/C0 | 1 = output enabled (running). 0 = output disabled asynchronously in a LOW state. |

Byte 6: Reserve Register

| Bit | @Pup | Description |
|-----|------|-------------|
| 7 | 1 | Reserved. |
| 6 | 0 | Reserved. |
| 5 | 0 | Reserved. |
| 4 | 0 | Reserved. |
| 3 | 0 | Reserved. |
| 2 | 0 | Reserved. |
| 1 | 0 | Reserved. |
| 0 | 0 | Reserved. |

Byte 7: Dial-a-Frequency Control Register N

| Bit | @Pup | Name | Description |
|-----|------|----------|--|
| 7 | 0 | Reserved | Reserved for device function test. These bits are for programming the PLL's internal N register. This access allows the user to modify the CPU frequency at very high resolution (accuracy). All other synchronous clocks (clocks that are generated from the same PLL, such as PCI) remain at their existing ratios relative to the CPU clock. |
| 6 | 0 | N6, MSB | |
| 5 | 0 | N5 | |
| 4 | 0 | N4 | |
| 3 | 0 | N3 | |
| 2 | 0 | N2 | |
| 1 | 0 | N1 | |
| 0 | 0 | N0, LSB | |

Byte 8: Silicon Signature Register (all bits are Read-only)

| Bit | @Pup | Name | Description |
|-----|------|--------------|-----------------------------|
| 7 | 0 | Revision_ID3 | Revision ID bit [3] |
| 6 | 0 | Revision_ID2 | Revision ID bit [2] |
| 5 | 0 | Revision_ID1 | Revision ID bit [1] |
| 4 | 0 | Revision_ID0 | Revision ID bit [0] |
| 3 | 1 | Vender_ID3 | Cypress's Vendor ID bit [3] |
| 2 | 0 | Vender_ID2 | Cypress's VendorID bit [2] |
| 1 | 0 | Vender_ID1 | Cypress's Vendor ID bit [1] |
| 0 | 0 | Vender_ID0 | Cypress's Vendor ID bit [0] |

Byte9: Dial-A-Frequency Control Register R

| Bit | @Pup | Name | Description |
|-----|------|---------|--|
| 7 | 0 | | Reserved |
| 6 | 0 | R5, MSB | These bits are for programming the PLL's internal R register. This access allows the user to modify the CPU frequency at very high resolution (accuracy). All other synchronous clocks (clocks that are generated from the same PLL, such as PCI) remain at their existing ratios relative to the CPU clock. |
| 5 | 0 | R4 | |
| 4 | 0 | R3 | |
| 3 | 0 | R2 | |
| 2 | 0 | R1 | |
| 1 | 0 | R0 | |
| 0 | 0 | DAF_ENB | R and N register mux selection. 0=R and N values come from the ROM. 1=data is load from DAF (I2C) registers. |

Dial-a-Frequency Feature

SMBus Dial-a-frequency feature is available in this device via Byte7 and Byte9.

P is a PLL constant that depends on the frequency selection prior to accessing the Dial-a-Frequency feature.

Table 9.

| FS(4:0) | P |
|---------|----------|
| XXXXX | 96016000 |

Spread Spectrum Clock Generation (SSCG)

Spread Spectrum is enabled/disabled via SMBus register Byte 1, Bit 6.

Table 10. Spread Spectrum Table

| Mode | SST1 | SST0 | % Spread |
|------|------|------|----------|
| 0 | 0 | 0 | -1.5% |
| 0 | 0 | 1 | -1.0% |
| 0 | 1 | 0 | -0.7% |
| 0 | 1 | 1 | -0.5% |
| 1 | 0 | 0 | ±0.75% |
| 1 | 0 | 1 | ±0.5% |
| 1 | 1 | 0 | ±0.35% |
| 1 | 1 | 1 | ±0.25% |

Maximum Ratings^[3]

Input Voltage Relative to V_{SS} :..... $V_{SS} - 0.3V$
 Input Voltage Relative to V_{DDQ} or AV_{DD} :..... $V_{DD} + 0.3V$
 Storage Temperature: $-65^{\circ}C$ to $+150^{\circ}C$
 Operating Temperature:..... $0^{\circ}C$ to $+70^{\circ}C$
 Maximum ESD..... 2000V
 Maximum Power Supply:..... 5.5V

This device contains circuitry to protect the inputs against damage due to HIGH static voltages or electric field. However, precautions should be take to avoid application of any voltage higher than the maximum rated voltages to this circuit. For proper operation, V_{IN} and V_{OUT} should be constrained to the range.

$$V_{SS} < (V_{IN} \text{ or } V_{OUT}) < V_{DD}$$

Unused inputs must always be tied to an appropriate logic voltage level (either V_{SS} or V_{DD}).

DC Parameters ($V_{DD} = V_{DDPCI} = V_{DDAGP} = V_{DDR} = V_{DD48M} = V_{DDC} = 3.3V \pm 5\%$, $V_{DDI} = V_{DD} = 2.5 \pm 5\%$, $T_A = 0^{\circ}C$ to $+70^{\circ}C$)

| Parameter | Description | Conditions | Min. | Typ. | Max. | Unit |
|-----------|-----------------------------------|---|------|------|------|---------|
| VIL1 | Input LOW Voltage | Applicable to PD#, F S(0:4) | | | 1.0 | Vdc |
| VIH1 | Input HIGH Voltage | | 2.0 | | | Vdc |
| VIL2 | Input LOW Voltage | Applicable to SDATA and SCLK | | | 1.0 | Vdc |
| VIH2 | Input HIGH Voltage | | 2.2 | | | Vdc |
| Vol | Output LOW Voltage for Sreset# | IOL | 0.4 | | | V |
| Iol | Pull-down Current for Sreset# | VOL = 0.4V | 24 | 35 | | mA |
| Ioz | Three-state Leakage Current | | | | 10 | μA |
| Idd3.3V | Dynamic Supply Current | CPU frequency set at 133.3 ^[4] | | 156 | 180 | mA |
| Idd2.5V | Dynamic Supply Current | CPU frequency set at 133.3 MHz ^[4] | | 177 | 200 | mA |
| Ipd | Power-down Supply current | PD# = 0 | | 3.8 | 4.0 | mA |
| Ipup | Internal Pull-up Device Current | Input @ V_{SS} | | | -25 | μA |
| Ipdwn | Internal Pull-down Device Current | Input @ V_{DD} | | | 10 | μA |
| Cin | Input Pin Capacitance | | | | 5 | pF |
| Cout | Output Pin Capacitance | | | | 6 | pF |
| Lpin | Pin Inductance | | | | 7 | pF |
| Cxtal | Crystal Pin Capacitance | Measured from the X_{IN} or X_{OUT} to V_{SS} | 27 | 36 | 45 | pF |

AC Parameters

| Parameter | Description | 66 MHz | | 100 MHz | | 133 MHz | | 200 MHz | | Unit | Notes |
|----------------|---------------------------|-------------|-------------|-------------|-------------|-------------|-------------|-------------|-------------|------|-------------|
| | | Min. | Max. | Min. | Max. | Min. | Max. | Min. | Max. | | |
| Crystal | | | | | | | | | | | |
| TDC | Xin Duty Cycle | 45 | 55 | 45 | 55 | 45 | 55 | 45 | 55 | % | 5,6,7,8 |
| TPeriod | Xin Period | 69.84 | 71.0 | 69.84 | 71.0 | 69.84 | 71.0 | 69.84 | 71.0 | ns | 5,6,7,8 |
| VHIGH | Xin HIGH Voltage | $0.7V_{DD}$ | V_{DD} | $0.7V_{DD}$ | V_{DD} | $0.7V_{DD}$ | V_{DD} | $0.7V_{DD}$ | V_{DD} | V | 7,9 |
| VLOW | Xin LOW Voltage | 0 | $0.3V_{DD}$ | 0 | $0.3V_{DD}$ | 0 | $0.3V_{DD}$ | 0 | $0.3V_{DD}$ | V | |
| Tr / Tf | Xin Rise and Fall Times | | 10.0 | | 10.0 | | 10 | | 10 | ns | 7 |
| TCCJ | Xin Cycle to Cycle Jitter | | 500 | | 500 | | 500 | | 500 | ps | 10,11,12,13 |
| Txs | Crystal Start-up Time | | 30 | | 30 | | 30 | | 30 | ms | 9 |

Notes:

- Multiple Supplies:** The Voltage on any input or I/O pin cannot exceed the power pin during power-up. Power supply sequencing is NOT required.
- All outputs loaded as per maximum capacitive load table in P4 and DDR mode. See *Table 12*.
- All outputs loaded as per loading specified in the loading table. See *Table 12*.
- This measurement is applicable with Spread ON or spread OFF.
- This is required for the duty cycle on the REF clock out to be as specified. The device will operate reliably with input duty cycles up to 30/70 but the REF clock duty cycle will not be within data sheet specifications.
- The typical value of VX is expected to be $0.5 \cdot V_{DDD}$ (or $0.5 \cdot V_{DDC}$ for CPUCS signals) and will track the variations in the DC level of the same.
- Measured between $0.2V_{dd}$ and $0.7V_{dd}$.
- Probes are placed on the pins, and measurements are acquired between 0.4V and 2.4V for 3.3V signals and between 0.4V and 2.0V for 2.5V signals, and between 20% and 80% for differential signals.
- Probes are placed on the pins, and measurements are acquired at 2.4V for 3.3V signals and at 2.0V for 2.5V signals.
- When Xin is driven from an external clock source (3.3V parameters apply).
- When Crystal meets minimum 40 ohm device series resistance specification.

AC Parameters (continued)

| Parameter | Description | 66 MHz | | 100 MHz | | 133 MHz | | 200 MHz | | Unit | Notes |
|----------------------------|---|--------|--------|---------|--------|---------|--------|---------|--------|------|------------------|
| | | Min. | Max. | Min. | Max. | Min. | Max. | Min. | Max. | | |
| P4 Mode CPU at 0.7V | | | | | | | | | | | |
| TDC | CPUT/C Duty Cycle | 45 | 55 | 45 | 55 | 45 | 55 | 45 | 55 | % | 5,6,10,14,15 |
| TPeriod | CPUT/C Period | 14.85 | 15.3 | 9.85 | 10.2 | 7.35 | 7.65 | 4.85 | 5.1 | ns | 5,6,10,14,15 |
| Tr/Tf | CPUT/C Rise and Fall Times | 175 | 700 | 175 | 700 | 175 | 700 | 175 | 700 | ps | 15,16 |
| | Rise/Fall Matching | | 20% | | 20% | | 20% | | 20% | | 16,17 |
| Delta Tr/Tf | Rise/Fall Time Variation | | 125 | | 125 | | 125 | | 125 | ps | 10,15,16,18 |
| TSKEW | CPUT/C to CPUCS_T/C Clock Skew | | 100 | | 100 | | 100 | | 100 | ps | 10,11,12,14,15 |
| TCCJ | CPUT/C Cycle-to-Cycle Jitter | | 150 | | 150 | | 150 | | 150 | ps | 6,10,11,12,14,15 |
| Vcross | Crossing Point Voltage | 280 | 430 | 280 | 430 | 280 | 430 | 280 | 430 | mV | 15. |
| P4 Mode CPU at 1.0V | | | | | | | | | | | |
| TDC | CPUT/C Duty Cycle | 45 | 55 | 45 | 55 | 45 | 55 | 45 | 55 | % | 5,10,6,14 |
| TPeriod | CPUT/C Period | 14.85 | 15.3 | 9.85 | 10.2 | 7.35 | 7.65 | 4.85 | 5.1 | nS | 5,10,6,14 |
| Differential Tr/Tf | CPUT/C Rise and Fall Times | 175 | 467 | 175 | 467 | 175 | 467 | 175 | 467 | ps | 10,11,19 |
| Delta Tr/Tf | Rise/Fall Time Variation | | 125 | | 125 | | 125 | | 125 | ps | 10,18 |
| TSKEW | CPUT/C to CPUCS_T/C Clock Skew | | 100 | | 100 | | 100 | | 100 | ps | 10,11,12,14 |
| TCCJ | CPUT/C Cycle-to-Cycle Jitter | | 150 | | 150 | | 150 | | 150 | ps | 10,11,12,14 |
| Vcross | Crossing Point Voltage | 510 | 760 | 510 | 760 | 510 | 760 | 510 | 760 | mV | 19 |
| SE-DeltaSlew | Absolute Single-ended Rise/Fall Waveform Symmetry | | 325 | | 325 | | 325 | | 325 | ps | 20 |
| K7 Mode | | | | | | | | | | | |
| TDC | CPUOD_T/C Duty Cycle | 45 | 55 | 45 | 55 | 45 | 55 | 45 | 55 | % | 5,6,10 |
| TPeriod | CPUOD_T/C Period | 14.85 | 15.3 | 9.85 | 10.2 | 7.35 | 7.65 | 4.85 | 5.1 | ns | 5,6,10 |
| TLOW | CPUOD_T/C LOW Time | 2.8 | | 2.8 | | 1.67 | | 2.8 | | ns | 5,6,10 |
| Tf | CPUOD_T/C Fall Time | 0.4 | 1.6 | 0.4 | 1.6 | 0.4 | 1.6 | 0.4 | 1.6 | ns | 5,10,21 |
| TCCJ | CPUOD_T/C Cycle-to-Cycle Jitter | | ±250 | | ±250 | | ±250 | | ±250 | ps | 6,10 |
| VD | Differential Voltage AC | .4 | Vp+.6V | .4 | Vp+.6V | .4 | Vp+.6V | .4 | Vp+.6V | V | 22 |
| VX | Differential Crossover Voltage | 500 | 1100 | 500 | 1100 | 500 | 1100 | 500 | 1100 | mV | 23 |
| Chipset | | | | | | | | | | | |
| TDC | CPUCS_T/C Duty Cycle | 45 | 55 | 45 | 55 | 45 | 55 | 45 | 55 | % | 5,10,6 |

Notes:

14. Measured at VX between the rising edge and the following falling edge of the signal.
15. Determined as a fraction of $2 \cdot (Trise - Tfall) / (Trise + Tfall)$.
16. See figure 6 for 0.7V loading specification.
17. Measurement taken from differential waveform, from -0.35V to +0.35V.
18. The time specified is measured from when all VDD's reach their respective supply rail (3.3V and 2.5V) till the frequency output is stable and operating within specifications.
19. Ideally the probes should be placed on the pins. If there is a transmission line between the test point and the pin for one signal of the pair (e.g., CPU), you should add the same length transmission line to the other signal of the pair (e.g., AGP).
20. Measured in absolute voltage, i.e., single-ended measurement.
21. Probes are placed on the pins, and measurements are acquired at 1.5V for 3.3V signals and at 1.25V for 2.5V, and 50% point for differential signals.
22. Measured at VX, or where subtraction of CLK-CLK# crosses 0 volts.
23. VD is the magnitude of the difference between the measured voltage level on a DDRT (and CPUCS_T) clock and the measured voltage level on its complementary DDRC (and CPUCS_C) one.

AC Parameters (continued)

| Parameter | Description | 66 MHz | | 100 MHz | | 133 MHz | | 200 MHz | | Unit | Notes |
|---------------|-----------------------------------|------------------|------------------|------------------|------------------|------------------|------------------|------------------|------------------|------|------------|
| | | Min. | Max. | Min. | Max. | Min. | Max. | Min. | Max. | | |
| TPeriod | CPUCS_T/C Period | 15 | 15.5 | 10.0 | 10.5 | 7.35 | 7.65 | 4.85 | 5.1 | ns | 5,10,6 |
| Tr / Tf | CPUCS_T/C Rise and Fall Times | 0.4 | 1.6 | 0.4 | 1.6 | 0.4 | 1.6 | 0.4 | 1.6 | ns | 5,10,21 |
| VD | Differential Voltage AC | 0.4 | Vp+ 0.6V | 0.4 | Vp+ 0.6V | 0.4 | Vp+ 0.6V | 0.4 | Vp+ 0.6V | V | 24 |
| VX | Differential Crossover Voltage | 0.5*VD DI-0.2 | 0.5*VD DI+0.2 | 0.5*VD DI-0.2 | 0.5*VD DI+0.2 | 0.5*VD DI-0.2 | 0.5*VD DI+0.2 | 0.5*VD DI-0.2 | 0.5*VD DI+0.2 | V | 14 |
| AGP | | | | | | | | | | | |
| TDC | AGP(0:2) Duty Cycle | 45 | 55 | 45 | 55 | 45 | 55 | 45 | 55 | % | 5,6,10 |
| TPeriod | AGP(0:2) Period | 15 | 16 | 15 | 16 | 15 | 16 | 15 | 16 | ns | 5,6,10 |
| THIGH | AGP(0:2) HIGH Time | 5.25 | | 5.25 | | 5.25 | | 5.25 | | ns | 10,25 |
| TLOW | AGP(0:2) LOW Time | 5.05 | | 5.05 | | 5.05 | | 5.05 | | ns | 10,18 |
| Tr/Tf | AGP(0:2) Rise and Fall Times | 0.4 | 1.6 | 0.4 | 1.6 | 0.4 | 1.6 | 0.4 | 1.6 | ns | 10,21 |
| TSKEW | Any AGP to Any AGP Clock Skew | | 250 | | 250 | | 250 | | 250 | ps | 10,11,12 |
| TCCJ | AGP(0:2) Cycle-to-Cycle Jitter | | 500 | | 500 | | 500 | | 500 | ps | 6,10,11,12 |
| PCI | | | | | | | | | | | |
| TDC | PCI(_F,1:6) Duty Cycle | 45 | 55 | 45 | 55 | 45 | 55 | 45 | 55 | % | 5,6,10 |
| TPeriod | PCI(_F,1:6) Period | 30.0 | | 30.0 | | 30.0 | | 30.0 | | ns | 5,6,10 |
| THIGH | PCI(_F,1:6) HIGH Time | 12.0 | | 12.0 | | 12.0 | | 12.0 | | ns | 10,25 |
| TLOW | PCI(_F,1:6) LOW Time | 12.0 | | 12.0 | | 12.0 | | 12.0 | | ns | 10,18 |
| Tr/Tf | PCI(_F,1:6) Rise and Fall Times | 0.5 | 2.0 | 0.5 | 2.0 | 0.5 | 2.0 | 0.5 | 2.0 | ns | 10,21 |
| TSKEW | Any PCI to Any PCI Clock Skew | | 500 | | 500 | | 500 | | 500 | ps | 10,11,12 |
| TCCJ | PCI(_F,1:6) Cycle-to-Cycle Jitter | | 500 | | 500 | | 500 | | 500 | ps | 10,6,11,12 |
| 48 MHz | | | | | | | | | | | |
| TDC | 48-MHz Duty Cycle | 45 | 55 | 45 | 55 | 45 | 55 | 45 | 55 | % | 5,6,10 |
| TPeriod | 48-MHz Period | 20.8299 | 20.8333 | 20.8299 | 20.8333 | 20.8299 | 20.8333 | 20.8299 | 20.8333 | ns | 5,6,10 |
| Tr/Tf | 48-MHz Rise and Fall Times | 1.0 | 4.0 | 1.0 | 4.0 | 1.0 | 4.0 | 1.0 | 4.0 | ns | 10,21 |
| TCCJ | 48-MHz Cycle-to-Cycle Jitter | | 500 | | 500 | | 500 | | 500 | ps | 10,6,11,12 |
| 24 MHz | | | | | | | | | | | |
| TDC | 24-MHz Duty Cycle | 45 | 55 | 45 | 55 | 45 | 55 | 45 | 55 | % | 5,6,10 |
| TPeriod | 24-MHz Period | 41.660 | 41.667 | 41.660 | 41.667 | 41.660 | 41.667 | 41.660 | 41.667 | ns | 5,6,10 |
| Tr / Tf | 24-MHz Rise and Fall Times | 1.0 | 4.0 | 1.0 | 4.0 | 1.0 | 4.0 | 1.0 | 4.0 | ns | 10,21 |
| TCCJ | 24-MHz Cycle-to-Cycle Jitter | | 500 | | 500 | | 500 | | 500 | ps | 6,10,11,12 |

Notes:

24. Measured at VX between the falling edge and the following rising edge of the signal.
 25. Probes are placed on the pins, and measurements are acquired at 0.4V.

AC Parameters (continued)

| Parameter | Description | 66 MHz | | 100 MHz | | 133 MHz | | 200 MHz | | Unit | Notes |
|------------|---------------------------------------|------------------|------------------|------------------|------------------|------------------|------------------|------------------|------------------|------|------------|
| | | Min. | Max. | Min. | Max. | Min. | Max. | Min. | Max. | | |
| REF | | | | | | | | | | | |
| TDC | REF Duty Cycle | 45 | 55 | 45 | 55 | 45 | 55 | 45 | 55 | % | 5,10,6 |
| TPeriod | REF Period | 69.8413 | 71.0 | 69.8413 | 71.0 | 69.8413 | 71.0 | 69.8413 | 71.0 | ns | 5,6,10 |
| Tr/Tf | REF Rise and Fall Times | 1.0 | 4.0 | 1.0 | 4.0 | 1.0 | 4.0 | 1.0 | 4.0 | ns | 10,21 |
| TCCJ | REF Cycle-to-Cycle Jitter | | 1000 | | 1000 | | 1000 | | 1000 | ps | 6,10,11,12 |
| DDR | | | | | | | | | | | |
| VX | Crossing Point Voltage of DDRT/C | 0.5*VD DD-0.2 | 0.5*VD DD+0.2 | 0.5*VD DD-0.2 | 0.5*VD DD+0.2 | 0.5*VD DD-0.2 | 0.5*VD DD+0.2 | 0.5*VD DD-0.2 | 0.5*VD DD+0.2 | V | 23 |
| VD | Differential Voltage Swing | 0.7 | VDDD + 0.6 | 0.7 | VDDD + 0.6 | 0.7 | VDDD + 0.6 | 0.7 | VDDD + 0.6 | V | 22 |
| TDC | DDRT/C(0:5) Duty Cycle | 45 | 55 | 45 | 55 | 45 | 55 | 45 | 55 | % | 14 |
| TPeriod | DDRT/C(0:5) Period | 14.85 | 15.3 | 9.85 | 10.2 | 14.85 | 15.3 | 9.85 | 10.2 | ns | 14 |
| Tr/Tf | DDRT/C(0:5) Rise/Fall Slew Rate | 1 | 3 | 1 | 3 | 1 | 3 | 1 | 3 | V/ns | 21 |
| TSKEW | DDRT/C to Any DDRT/C Clock Skew | | 100 | | 100 | | 100 | | 100 | ps | 10,11,14 |
| TCCJ | DDRT/C(0:5) Cycle-to-Cycle Jitter | | ±75 | | ±75 | | ±75 | | ±75 | ps | 10,11,14 |
| THPJ | DDRT/C(0:5) Half Period Jitter | | ±100 | | ±100 | | ±100 | | ±100 | ps | 10,11,14 |
| TDelay | BUF_IN to Any DDRT/C Delay | 1 | 4 | 1 | 4 | 1 | 4 | 1 | 4 | ns | 6,10 |
| TSKEW | FBOUT to Any DDRT/C Skew | | 100 | | 100 | | 100 | | 100 | ps | 6,10 |
| tstable | All Clock Stabilization from Power-up | | 1.5 | | 1.5 | | 1.5 | | 1.5 | ms | 12 |

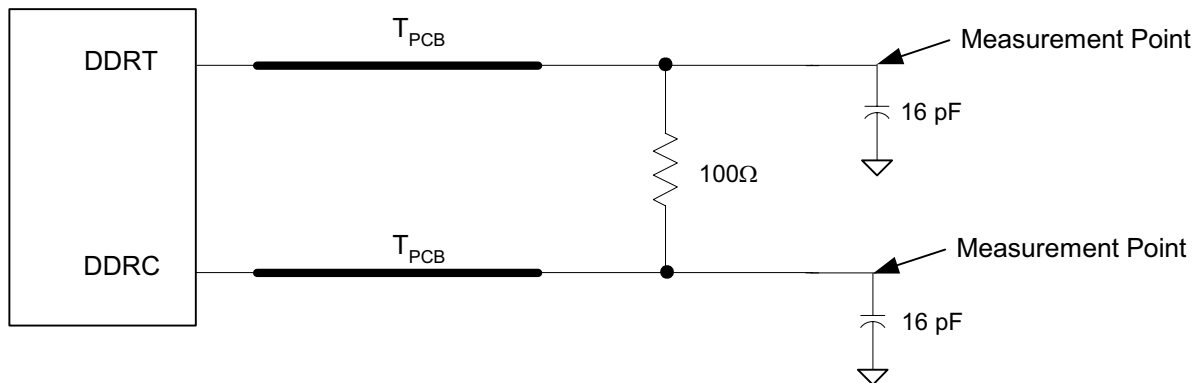
Connection Circuit DDRT/C Signals

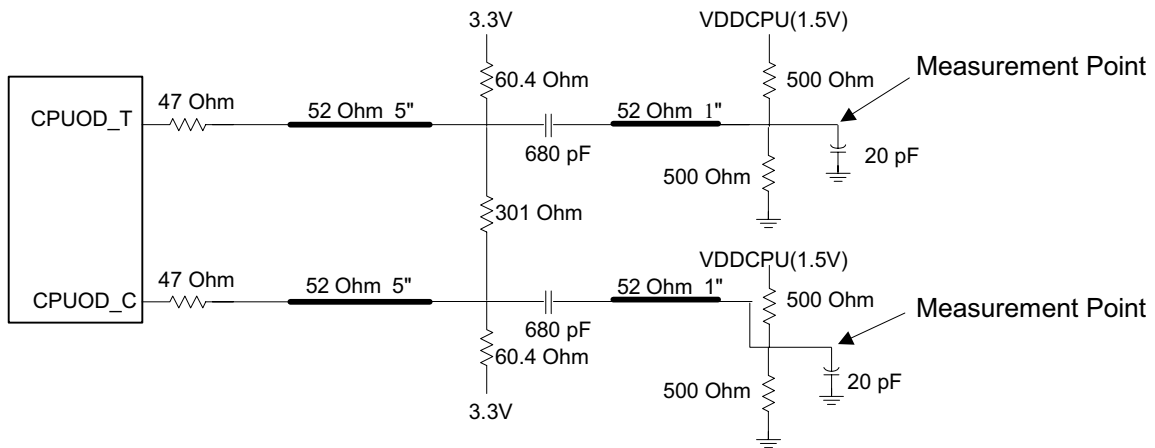
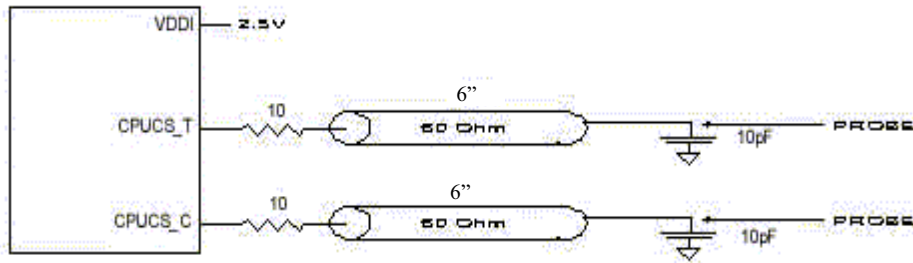
Figure 1. Differential DDR Termination

**For Open Drain CPU Output Signals
(with K7 Processor SELP4_K7# = 0)**

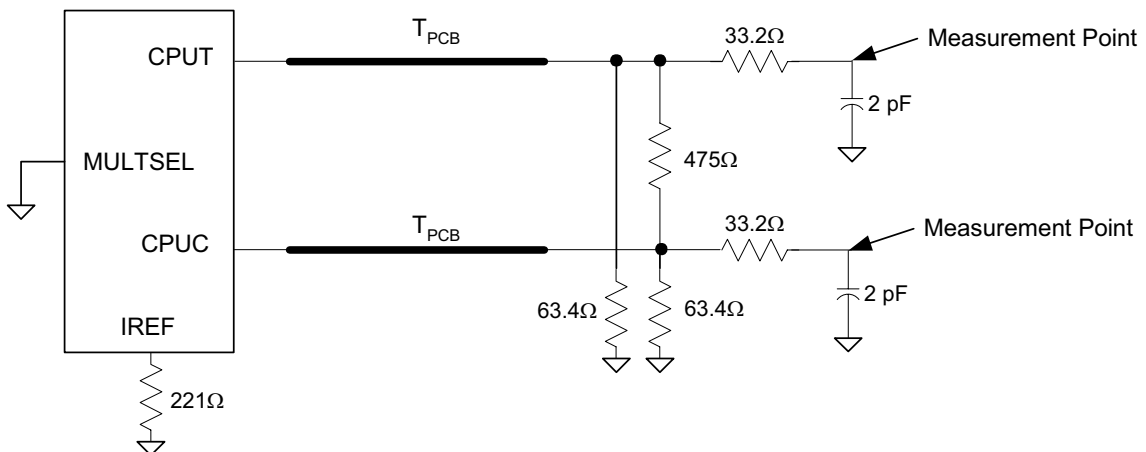
Figure 2. K7 Termination

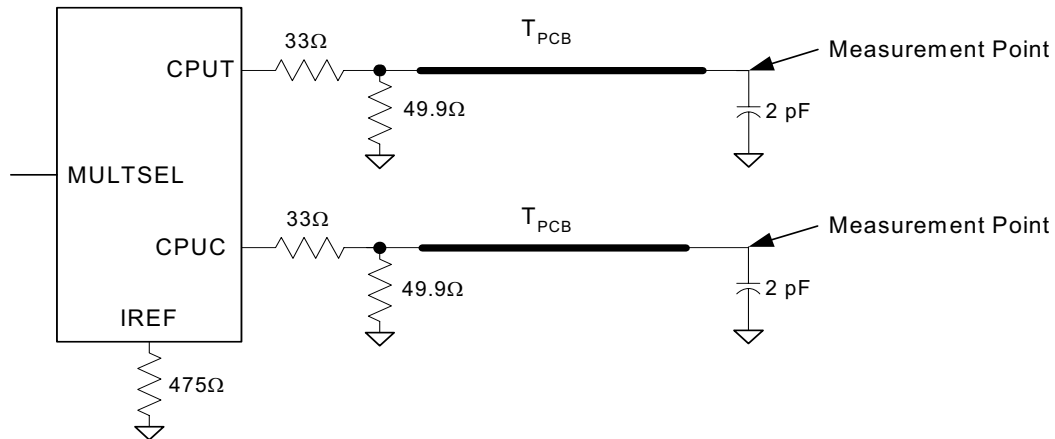
Figure 3. Chipset Termination
For Differential CPU Output Signals (with P4 Processor SELP4_K7# = 1)

The following diagram shows lumped test load configurations for the differential Host Clock Outputs. *Figure 4* is for the 1.0V amplitude signalling and *Figure 5* is for the 0.7V amplitude signalling.

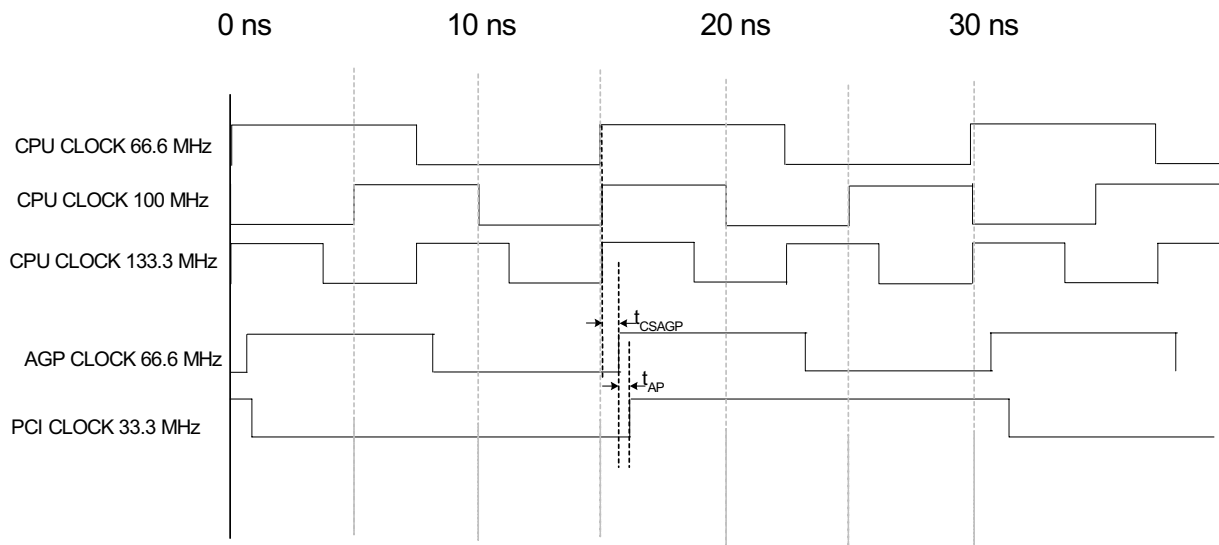

Figure 4. P4 1.0V Configuration

Figure 5. P4 0.7V Configuration
Table 11. Group Timing Relationships and Tolerances

| | | Offset (ps) | Tolerance (ps) | Conditions |
|-------------|--------------|-------------|----------------|-------------|
| t_{CSAGP} | CPUCS to AGP | 750 | 500 | CPUCS Leads |
| t_{AP} | AGP to PCI | 500 | 500 | AGP Leads |

Table 12. Signal Loading

| Clock Name | Max. Load (in pF) |
|----------------------------------|---------------------------|
| REF (0:1), 48MHz (USB), 24_48MHz | 20 |
| AGP(0:2), PCI_F(0:5)SDRAM (0:11) | 30 |
| FBOUT | 10 |
| DDRT/C | See Figure 1 |
| CPUT/C | See Figure 4 and Figure 5 |
| CPUOD_T/C | See Figure 2 |
| CPUCS_T/C | See Figure 3 |

Figure 6. Clock Timing Relationships

CPU_STP# Assertion (P4 Mode)

When CPU_STP# pin is asserted, all CPU outputs will be stopped after being sampled by two rising CPUC clock edges. The final state of the stopped CPU signal is CPUT = HIGH and CPUC = LOW. There is no change to the output drive current

values during the stopped state. The CPUT is driven HIGH with a current value equal to (Mult 0 "select") x (Iref), and the CPUC signal will not be driven. Due to external pulldown circuitry CPUC will be LOW during this stopped state.

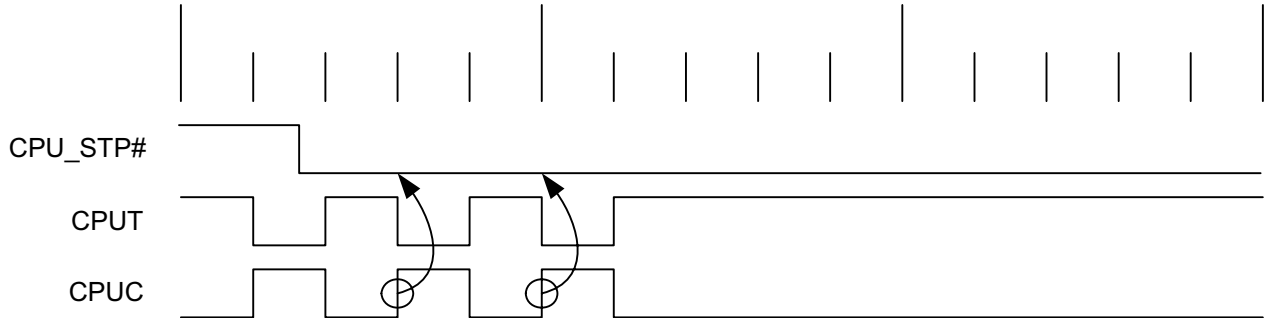
Figure 7. CPU_STP# Assertion Waveform (P4 Mode)
Table 13. CPU_STP# Functionality

| CPU_STP# | CPU#4 | CPU |
|----------|-----------|--------|
| 1 | Normal | Normal |
| 0 | Iref*Mult | Float |

CPU_STP# Deassertion (P4 Mode)

The deassertion of the CPU_STP# signal will cause all CPU outputs that were stopped to resume normal operation in a synchronous manner. Synchronous manner meaning that no short or stretched clock pulses will be produced when the clock resumes. The maximum latency from the deassertion to active outputs is no more than two CPU clock cycles.

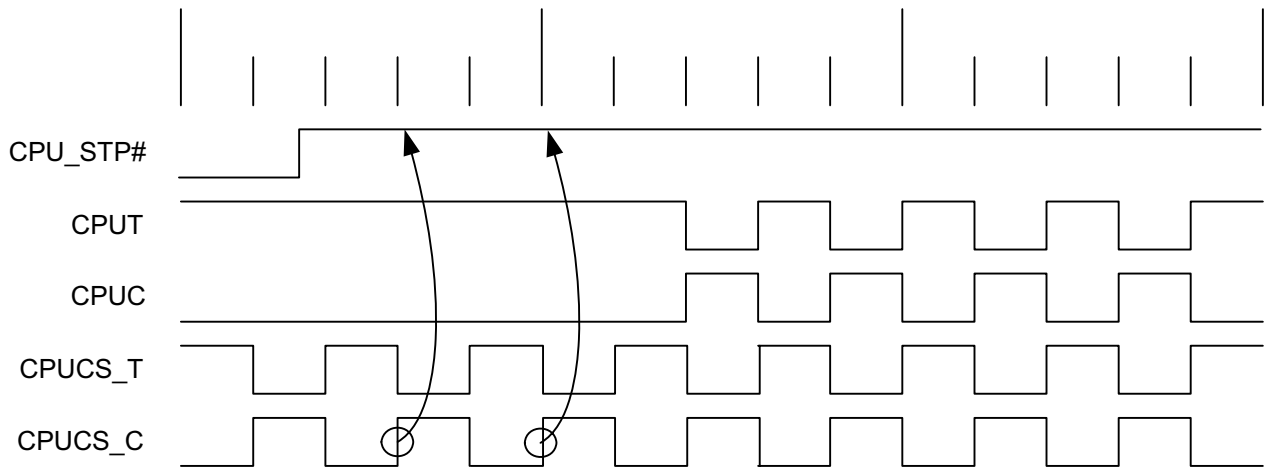
Figure 8. CPU_STP# Deassertion Waveform (P4 Mode)

CPU_STP# Assertion (K7 Mode)

When CPU_STP# pin is asserted, all CPU outputs will be stopped after being sampled by two rising CPUC clock edges.

The final state of the stopped CPU signal is CPUOD_T = LOW and CPUOD_C = LOW.

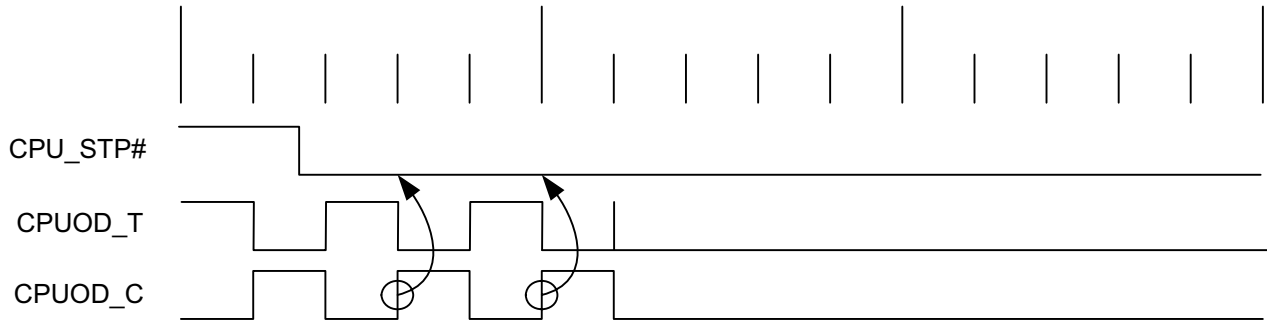

Figure 9. CPU_STP# Assertion Waveform (K7 Mode)

CPU_STP# Deassertion (K7 Mode)

The deassertion of the CPU_STP# signal will cause all CPU outputs that were stopped to resume normal operation in a synchronous manner. Synchronous manner meaning that no

short or stretched clock pulses will be produce when the clock resumes. The maximum latency from the deassertion to active outputs is no more than two CPU clock cycles.

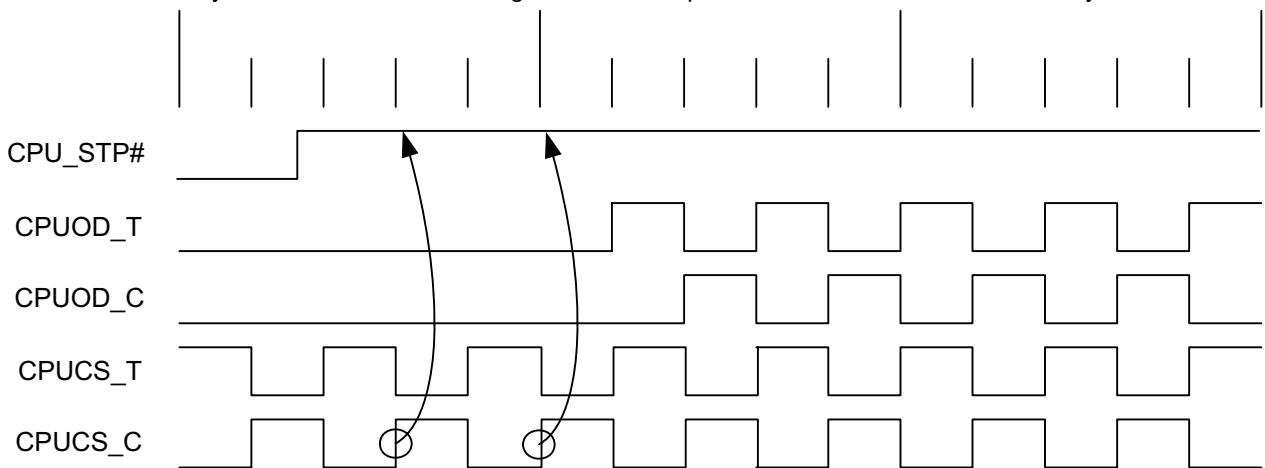

Figure 10. CPU_STP# Deassertion Waveform (K7 Mode)

PCI_STP# Assertion

The PCI_STP# signal is an active LOW input used for synchronous stopping and starting the PCI outputs while the rest of the clock generator continues to function. The setup

time for capturing PCI_STP# going LOW is 10 ns (t_{setup}). The PCI_F clock will not be affected by this pin.

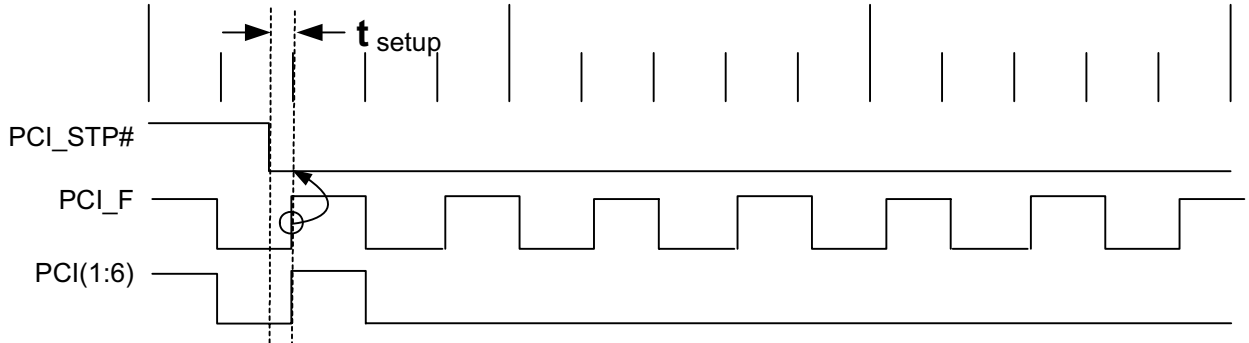

Figure 11. PCI_STP# Assertion Waveform

PCI_STP#- Deassertion

The deassertion of the PCI_STP# signal will cause all PCI clocks to resume running in a synchronous manner within one PCI clock period after PCI_STP# transitions to a HIGH level.

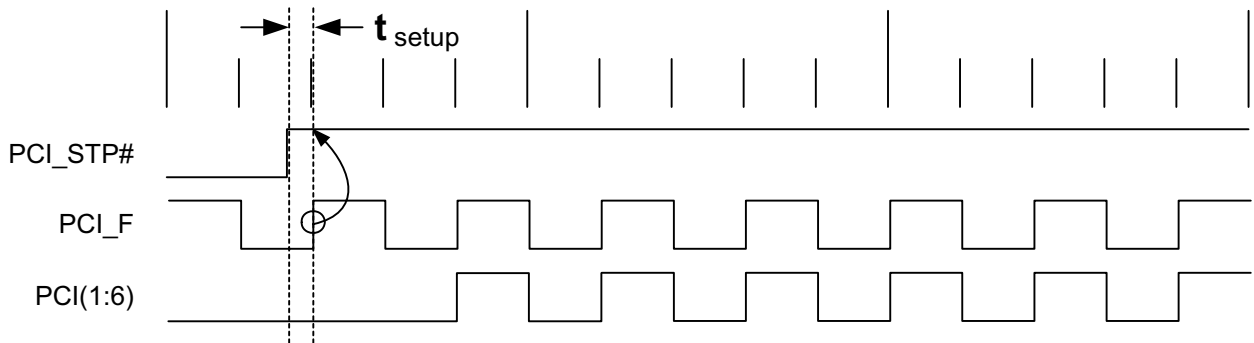

Figure 12. PCI_STP# Deassertion Waveform

Power Management Functions

All clocks can be individually enabled or stopped via the 2-wire control interface. All clocks maintain valid HIGH period on transitions from running to stop and on transitions from stopped to running when the chip was not powered OFF.

Power Down Assertion (P4 Mode)

When PD# is sampled LOW by two consecutive rising edges of CPUC clock then all clocks must be held LOW on their next HIGH to LOW transition. CPUT clocks must be held with a value of $2 \times I_{ref}$,

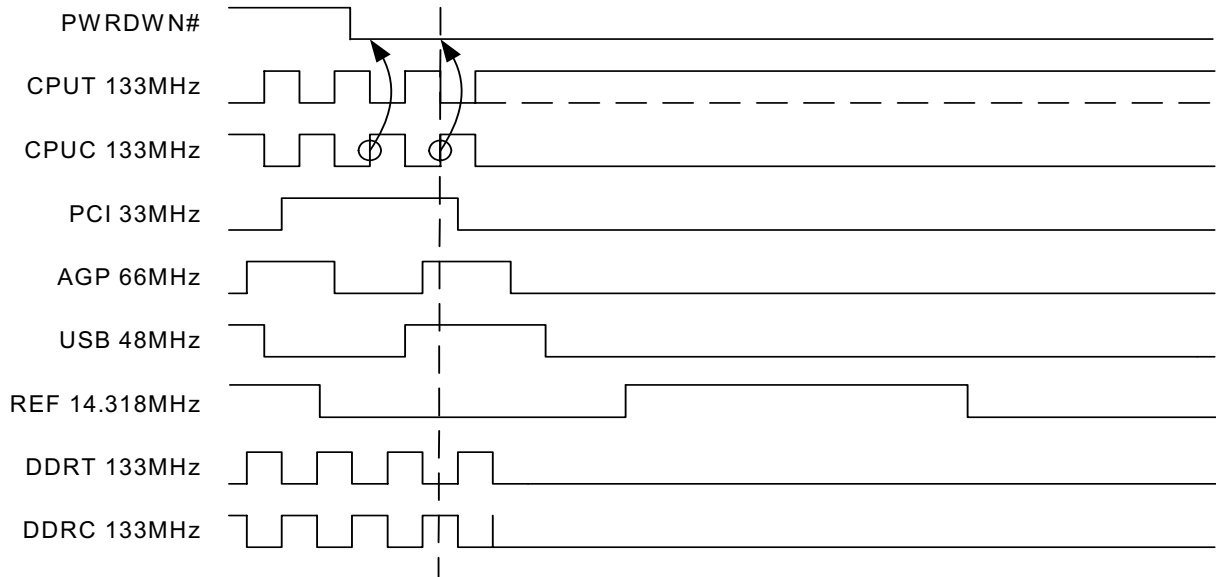
P4 Processor SELP4_K7# = 1.

Figure 13. Power-down Assertion Timing Waveform (in P4 Mode)
Power-down Deassertion (P4 Mode)

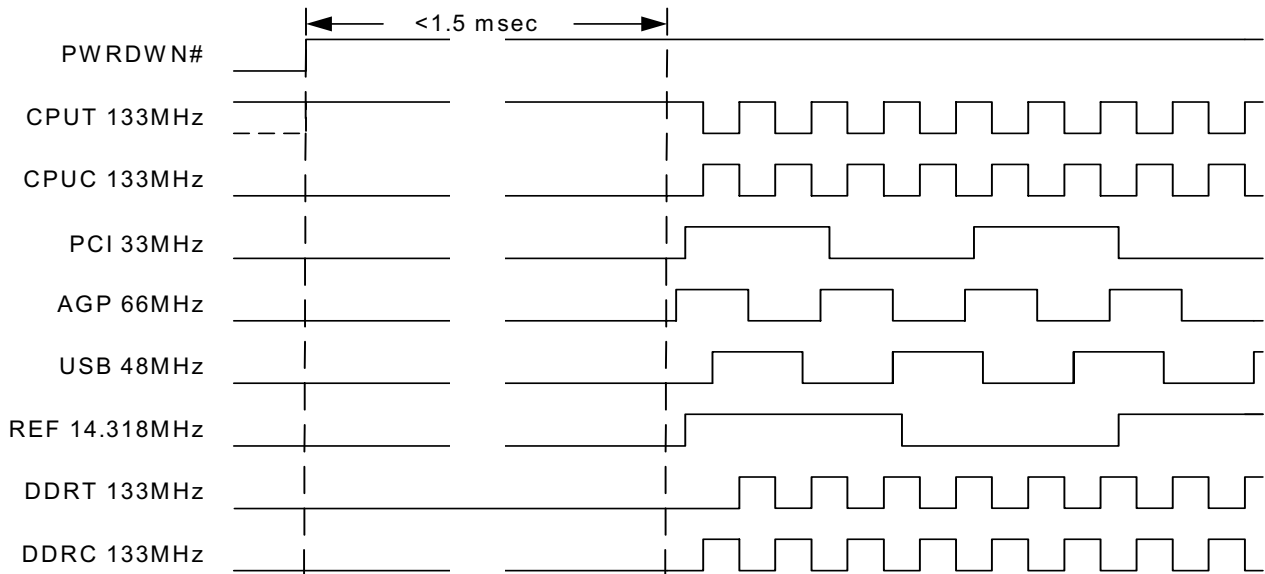
The power-up latency needs to less than 1.5mS.

Figure 14. Power-down Deassertion Timing Waveform (in P4 Mode)

AMD K7 processor SELP4 K7# = 0
Power-down Assertion (K7 Mode)

When the PD# signal is asserted LOW, all clocks are disabled to a LOW level in an orderly fashion prior to removing power from the CPU. When PD# is sampled LOW by two consecutive rising edges of the CPUCS_C clock, then all affected clocks are stopped in a LOW state after the next HIGH to LOW

transition or remains LOW. When in power-down (and before power is removed), all outputs are synchronously stopped in a LOW state (see *Figure 15* below), all PLLs are shut off, and the crystal oscillator is disabled. When the device is shutdown, the I2C function is also disabled.

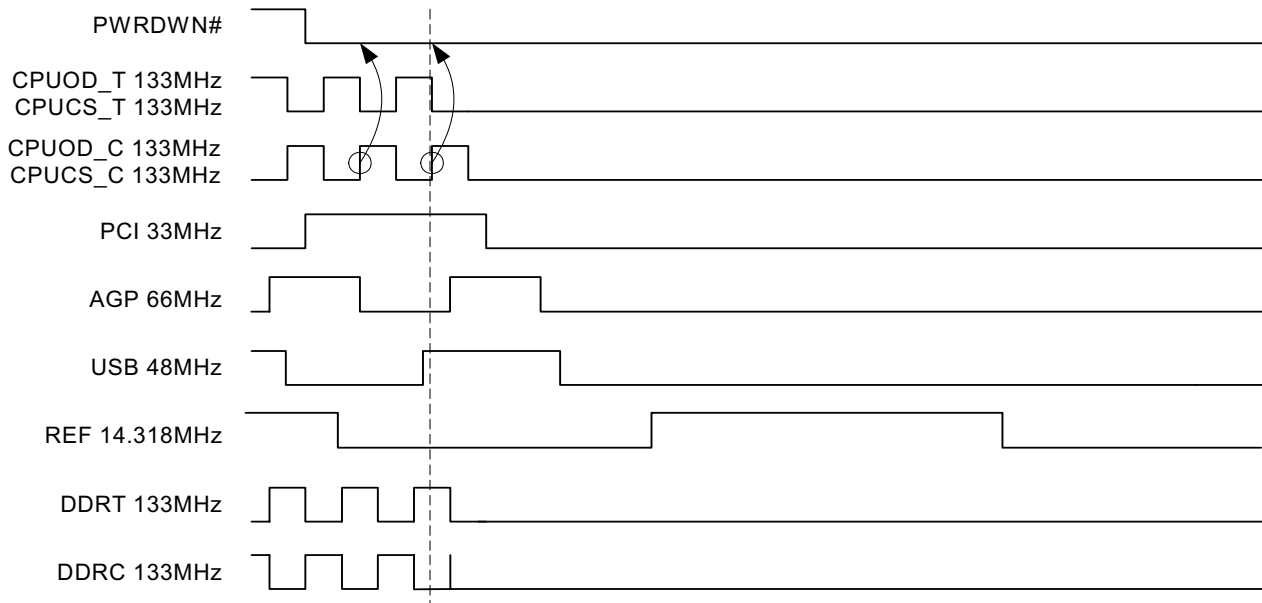

Figure 15. Power-down Assertion Timing Waveform (in K7 Mode)

Power Down Deassertion (K7 Mode)

When deasserted PD# to HIGH level, all clocks are enabled and start running on the rising edge of the next full period in

order to guarantee a glitch-free operation, no partial clock pulses.

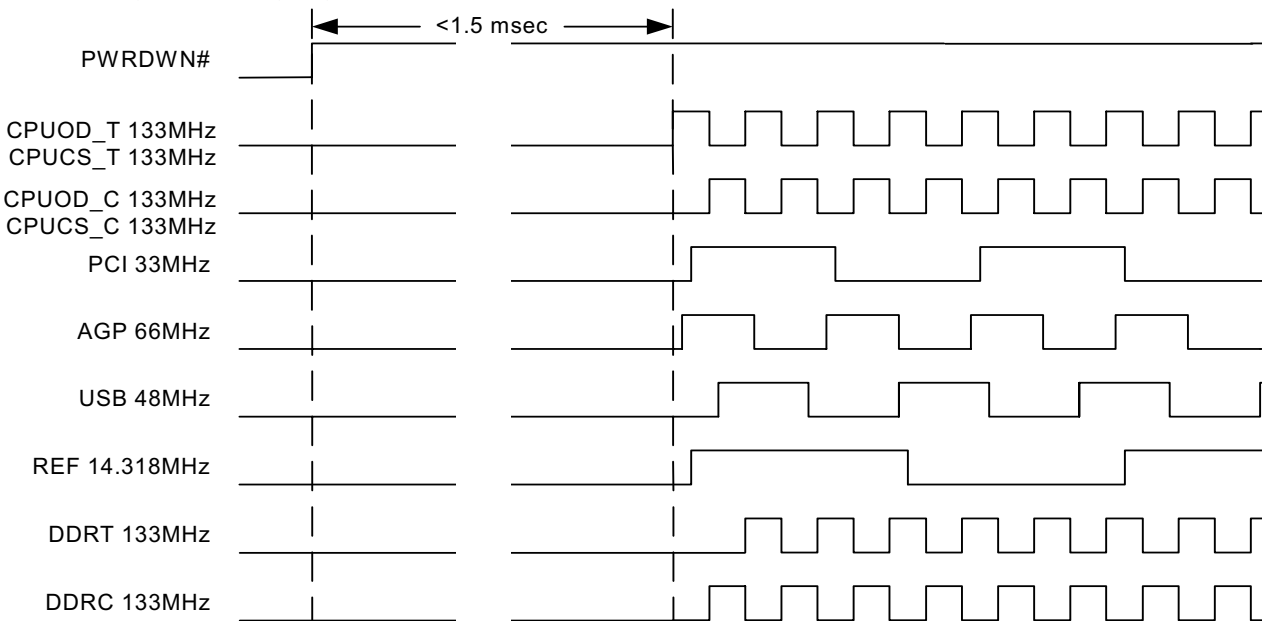

Figure 16. Power-down Deassertion Timing Waveform (in K7 Mode)

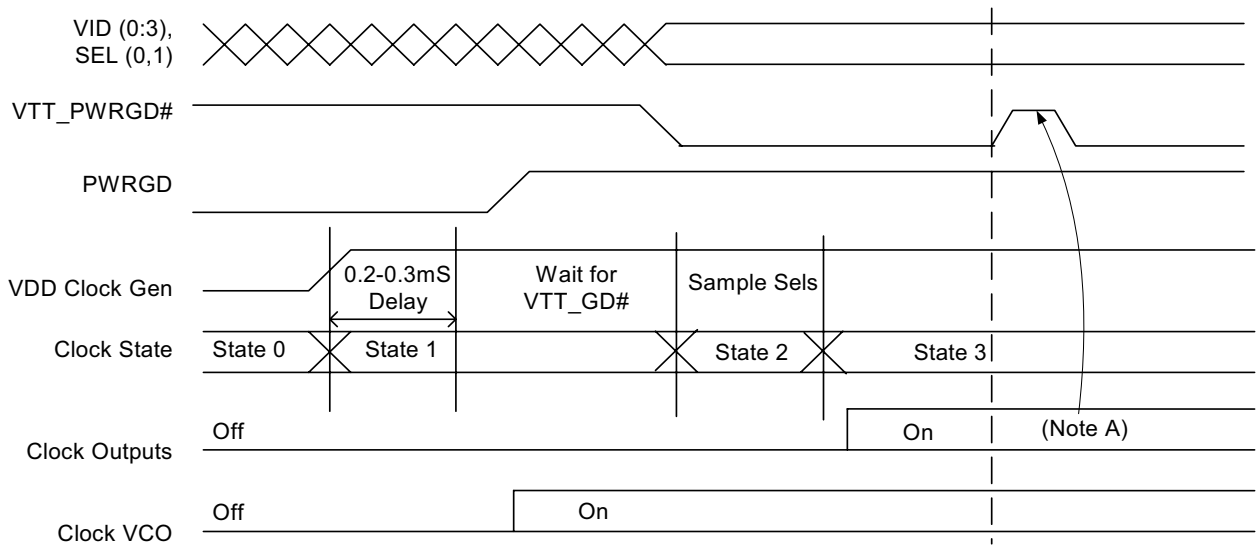

Figure 17. VTT_PWRGD# Timing Diagram (With Advanced PIII Processor SELP4_K7# = 1)^[26]

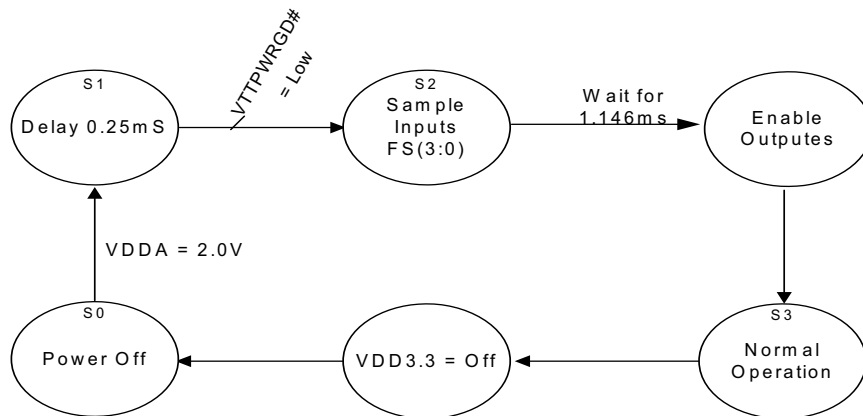

Figure 18. Clock Generator Power-up/Run State Diagram (with P4 Processor SELP4_K7# = 1)

Ordering Information

| Part Number | Package Type | Product Flow |
|-------------|--|------------------------|
| CY28347OC | 56-pin Shrunk Small Outline Package (SSOP) | Commercial, 0° to 70°C |
| CY28347OCT | 56-pin Shrunk Small Outline Package (SSOP) – Tape and Reel | Commercial, 0° to 70°C |
| CY28347ZC | 56-pin Thin Shrunk Small Outline package (TSSOP) | Commercial, 0° to 70°C |
| CY28347ZCT | 56-pin Thin Shrunk Small Outline package (TSSOP) – Tape and Reel | Commercial, 0° to 70°C |

Note:

26. This timing diagram shows that VTT_PWRGD# transits to a logic LOW in the first time at power up. After the first HIGH to LOW transition of VTT_PWRGD#, device is not affected, VTT_PWRGD# is ignored.

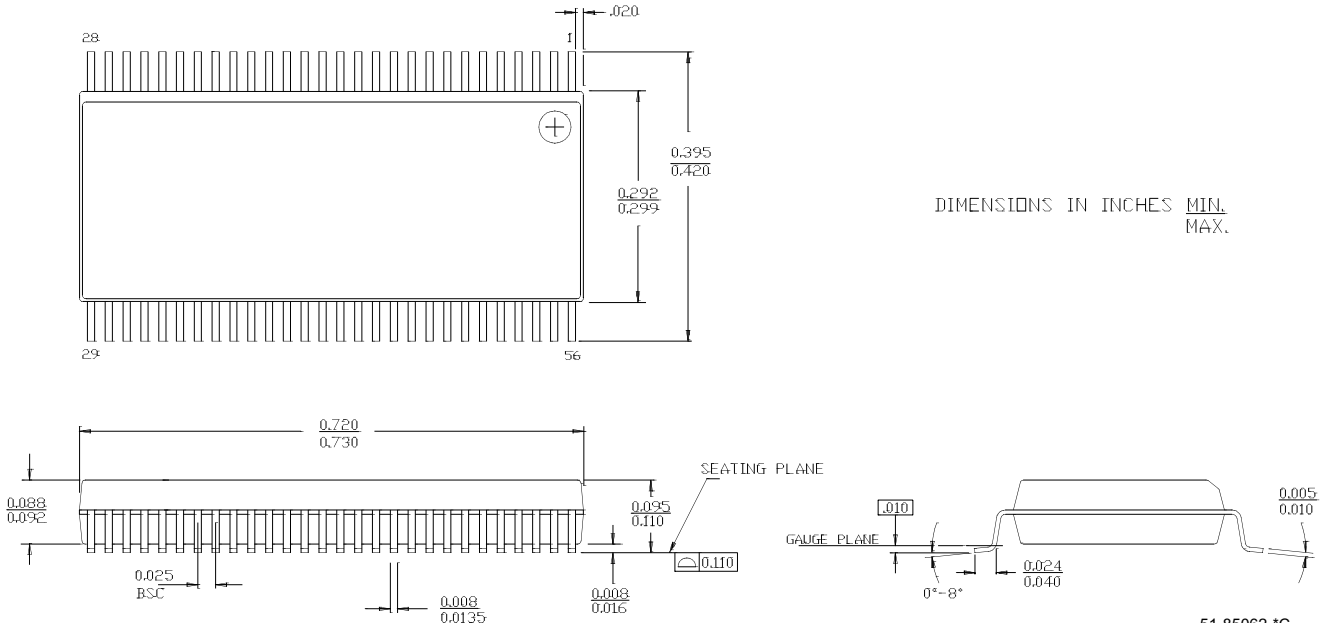
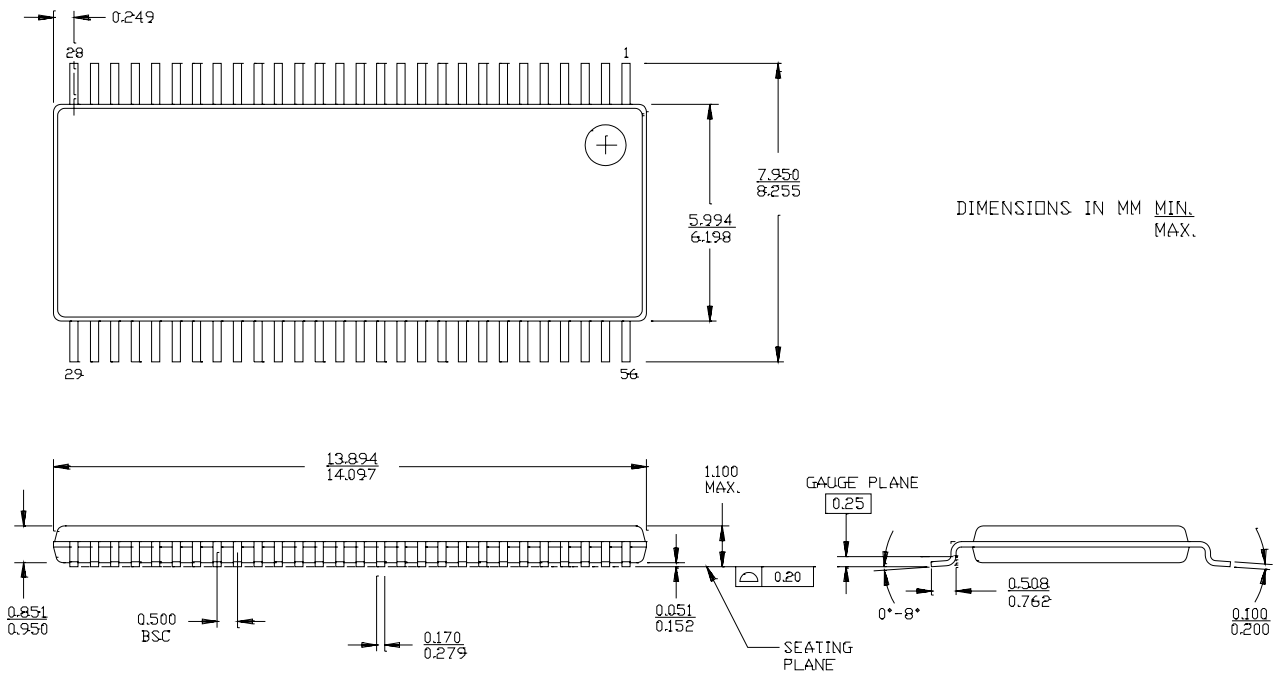
Package Drawing and Dimensions
56-lead Shrunk Small Outline Package O56

56-Lead Thin Shrunk Small Outline Package, Type II (6 mm x 14 mm) Z56

While SLI has reviewed all information herein for accuracy and reliability, Spectra Linear Inc. assumes no responsibility for the use of any circuitry or for the infringement of any patents or other rights of third parties which would result from each use. This product is intended for use in normal commercial applications and is not warranted nor is it intended for use in life support, critical medical instruments, or any other application requiring extended temperature range, high reliability, or any other extraordinary environmental requirements unless pursuant to additional processing by Spectra Linear Inc., and expressed written agreement by Spectra Linear Inc. Spectra Linear Inc. reserves the right to change any circuitry or specification without notice.