

**Ambient Light Photo Detect IC**

The EL7900 is a light-to-current optical sensor combining a photodiode and a current amplifier on a single monolithic IC. Output current is directly proportionate to the light intensity on the photodiode. Its sensitivity is superior to that of a phototransistor and exhibits little variation. Its spectral sensitivity matches closely to the luminous efficiency and linearity.

Housed in an ultra-compact surface mount clear plastic package, this device is excellent for power saving control function in cell phones, PDAs, and other handheld applications.

**Pinout**

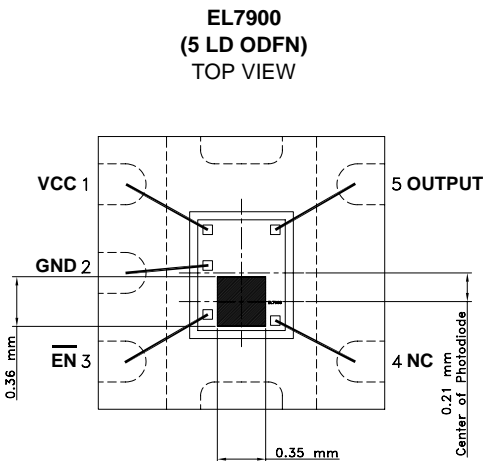

**Features**

- Monolithic IC containing photodiode and amplifier
- 1lux to 8,000lux range
- Converts light intensity to current
- 2.5V to 5.5V supply range
- Low supply current: 1µA
- Fast response time - <200µs
- Excellent output linearity of luminance
- Ultra-compact and light surface mount package
- Pb-free plus anneal available (RoHS compliant)

**Applications**

- Mobile phones
- Notebook PCs
- PDAs
- Video cameras
- Digital cameras

**Ordering Information**

PART NUMBER (Note)	TAPE & REEL	PACKAGE (Pb-free)	PKG. DWG. #
EL7900ILCZ	-	5 Ld ODFN	L5.2x2.1
EL7900ILCZ-T7	7"	5 Ld ODFN	L5.2x2.1

NOTE: Intersil Pb-free products employ special Pb-free material sets; molding compounds/die attach materials and 100% matte tin plate termination finish, which are RoHS compliant and compatible with both SnPb and Pb-free soldering operations. Intersil Pb-free products are MSL classified at Pb-free peak reflow temperatures that meet or exceed the Pb-free requirements of IPC/JEDEC J STD-020.

**Absolute Maximum Ratings** ( $T_A = +25^\circ\text{C}$ )

Supply Voltage between  $V_{SD}$  and GND ..... .6V  
 Maximum Continuous Output Current ..... .6mA  
 Operating Temperature ..... -40°C to +85°C  
 ESD Voltage ..... .2kV

Maximum Die Temperature ..... +125°C  
 Storage Temperature ..... -45°C to +100°C

*CAUTION: Stresses above those listed in "Absolute Maximum Ratings" may cause permanent damage to the device. This is a stress only rating and operation of the device at these or any other conditions above those indicated in the operational sections of this specification is not implied.*

*IMPORTANT NOTE: All parameters having Min/Max specifications are guaranteed. Typical values are for information purposes only. Unless otherwise noted, all tests are at the specified temperature and are pulsed tests, therefore:  $T_J = T_C = T_A$*

**Electrical Specifications**  $V_{CC} = 3\text{V}$ ,  $T_A = +25^\circ\text{C}$ , fluorescent light, unless otherwise specified.

PARAMETER	DESCRIPTION	CONDITION	MIN	TYP	MAX	UNIT
$I_{CC1}$	Supply Current	$R_L = 1\text{k}\Omega$ , EV = 100lux		62		$\mu\text{A}$
		EV = 0lux		1		$\mu\text{A}$
$I_{CC2}$	Supply Current When Disabled	$\overline{\text{EN}} = V_{HI}$		1.2		$\mu\text{A}$
$I_{L1}$	Light Current	EV = 100lux	39	60.5	82	$\mu\text{A}$
$I_{L2}$	Light Current	EV = 10lux		6.2		$\mu\text{A}$
$I_{LEAK}$	Dark Current	EV = 0lux		10		$\mu\text{A}$
$V_{O(MAX)}$	Maximum Output Compliance Voltage	at 95% of nominal output current, EV = 100lux		2.7		V
$t_R$	Rise Time (Note 1)	$R_L = 5\text{k}\Omega$ , EV = 300lux		105	125	$\mu\text{s}$
		$R_L = 1\text{k}\Omega$ , EV = 1000lux		64		$\mu\text{s}$
$t_F$	Fall Time (Note 1)	$R_L = 5\text{k}\Omega$ , EV = 300lux		170	225	$\mu\text{s}$
		$R_L = 1\text{k}\Omega$ , EV = 1000lux		77		$\mu\text{s}$
$t_D$	Delay Time for Rising Edge (Note 1)	$R_L = 5\text{k}\Omega$ , EV = 300lux		165	200	$\mu\text{s}$
		$R_L = 1\text{k}\Omega$ , EV = 1000lux		112		$\mu\text{s}$
$t_S$	Delay Time for Falling Edge (Note 1)	$R_L = 5\text{k}\Omega$ , EV = 300lux		65	85	$\mu\text{s}$
		$R_L = 1\text{k}\Omega$ , EV = 1000lux		33		$\mu\text{s}$
$V_{LO}$	Maximum Voltage at $\overline{\text{EN}}$ Pin to Enable				0.6	V
$V_{HI}$	Minimum Voltage at $\overline{\text{EN}}$ Pin to Disable		1.8			V
$I_{LO}$	Input Current at $\overline{\text{EN}}$ Pin	$V_{\overline{\text{EN}}} = 0\text{V}$		0.01		$\mu\text{A}$
$I_{HI}$	Input Current at $\overline{\text{EN}}$ Pin	$V_{\overline{\text{EN}}} = 3\text{V}$		2		$\mu\text{A}$
$t_{EN}$	Enable Time	EV = 200lux		140		$\mu\text{s}$
$t_{DIS}$	Disable Time	EV = 200lux		2		$\mu\text{s}$

NOTE:

1. Switching time measurement is based on Figures 1 and 2.

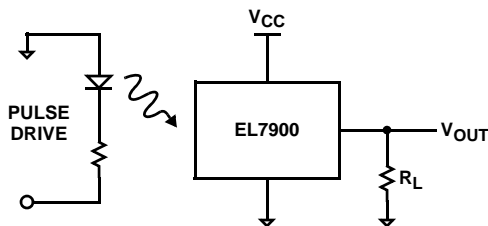

FIGURE 1. RISE/FALL TIME MEASUREMENT

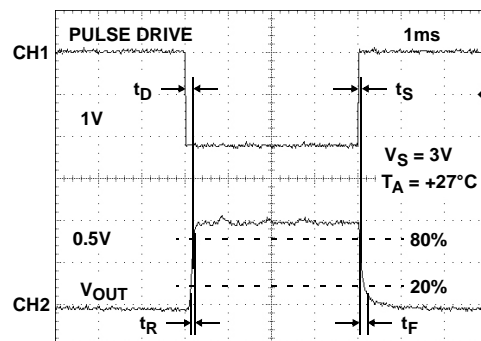

FIGURE 2. RISE/FALL TIME MEASUREMENT WAVEFORMS

Typical Performance Curves

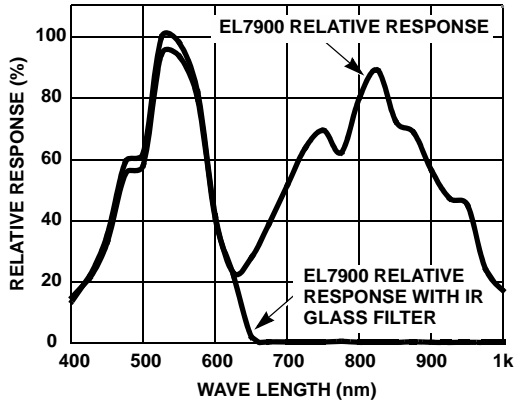

FIGURE 3. SPECTRAL RESPONSE

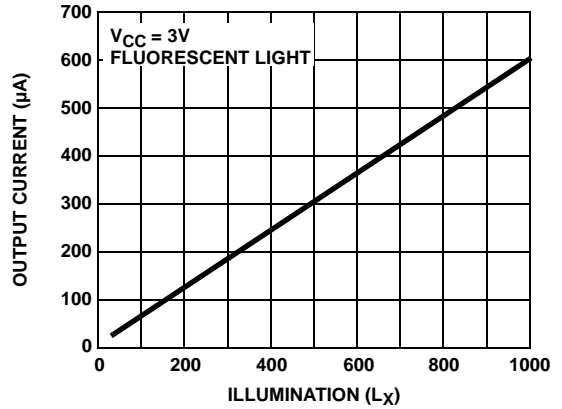

FIGURE 4. SENSITIVITY

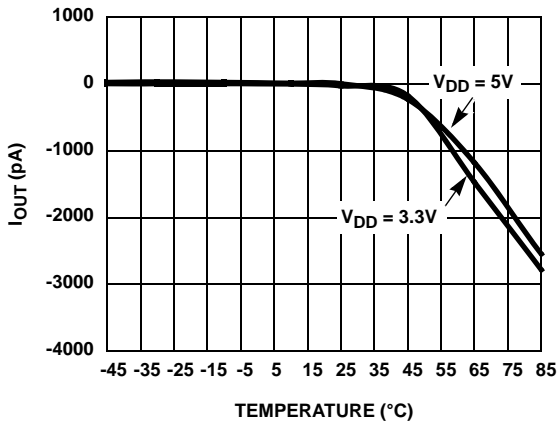

FIGURE 5. DARK CURRENT vs TEMPERATURE

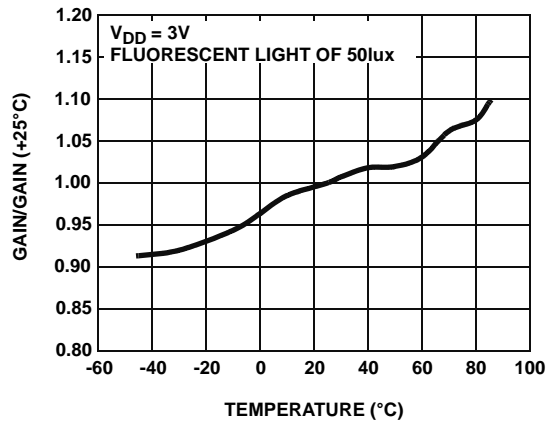

FIGURE 6. GAIN vs TEMPERATURE

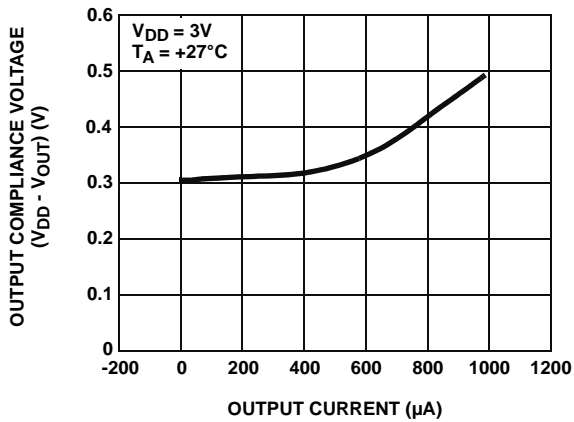

FIGURE 7. OUTPUT COMPLIANCE VOLTAGE vs CURRENT

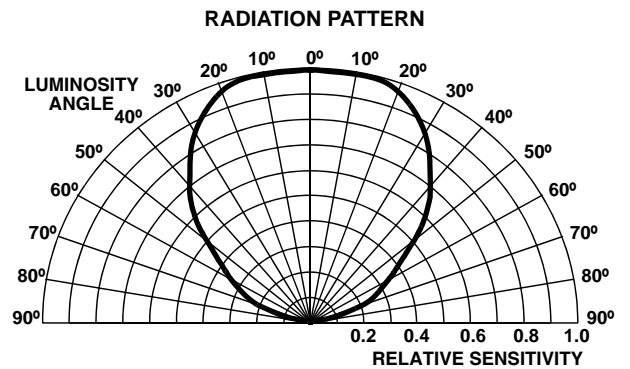

FIGURE 8. RADIATION PATTERN

Typical Performance Curves

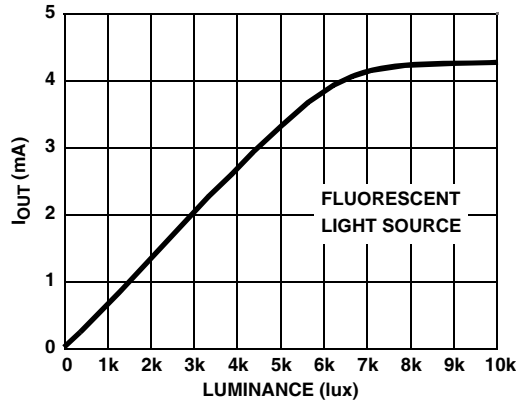
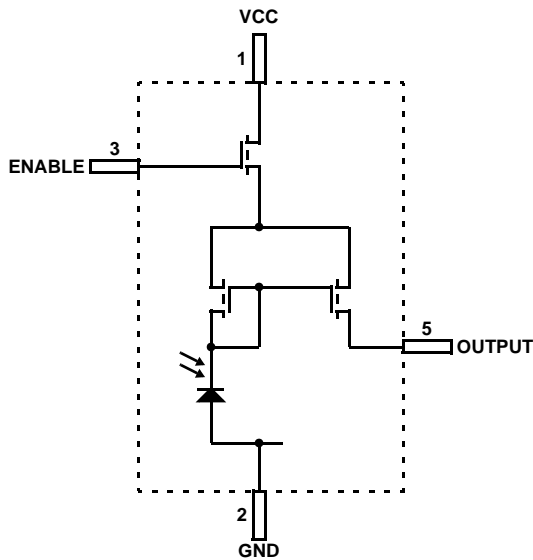

FIGURE 9. I<sub>OUT</sub> vs LUMINANCE

Pin Descriptions

PIN	NAME	DESCRIPTION
1	VCC	Supply, 2.5V to 5.5V
2	GND	Ground
3	$\overline{\text{EN}}$	Enable
4	NC	No connect
5	Output	Current output pin

Block Diagram



Application Information

Product Description

The EL7900 is a light-to-current optical sensor combining photodiodes and current amplifiers on a single monolithic IC. The photodiodes are temperature-compensated and their spectrum resembles the human eye response. The output current is directly proportional to the intensity of light falling on the photodiodes. For 100lux of input fluorescent light, the EL7900 has an output current of 60µA.

The EL7900 is housed in an ultra-compact surface mount clear plastic package.

Light-to-Current and Voltage Conversion

The EL7900 has a responsiveness that is directly proportional to the intensity of light intercepted by the photodiodes. Although the conversion rate varies depending on the light sources (fluorescent light, incandescent light or direct sunlight), in general for a fluorescent light, the light-to-current conversion is:

$$I_{OUT} = \left( \frac{60\mu A}{100\text{lux}} \right) \times L_{INPUT} \quad (\text{EQ. 1})$$

Here, I<sub>OUT</sub> is the output current in µA, and L<sub>INPUT</sub> is the input light in lux.

For some applications, a load resistor is added between the output and the ground as shown in Figure 1. The output voltage can be expressed in the following equation:

$$V_{OUT} = I_{OUT} \times R_{LOAD} = \left( \frac{60\mu A}{100\text{lux}} \right) \times L_{INPUT} \times R_{LOAD} \quad (\text{EQ. 2})$$

Here, V<sub>OUT</sub> is the output voltage and R<sub>LOAD</sub> is the value of the load resistor added. The compliance of the EL7900's output circuit may result in premature saturation of the output current and voltage when an excessively large R<sub>LOAD</sub> is used. The output compliance voltage is 300mV below the supply voltage as listed in V<sub>O(MAX)</sub> of the Electrical Specifications table on page 2.

In order to have the linear relationship between the input light and the output current and voltage, a proper resistor value (i.e., gain) should be picked for a specific input light range. The resistor value can be picked according to the following equation:

$$R_{LOAD} = \frac{(V_{SUP} - 0.3V)}{60\mu A} \times \frac{100lux}{L_{RANGE}} \quad (EQ. 3)$$

Here,  $V_{SUP}$  is the supply voltage, and  $L_{RANGE}$  is the specific input light range for an application. For example, an indoor light ranges typically from 0lux to 1,000lux. A resistor value of 4.5k $\Omega$  for 3V supply voltage can be used. For a small light range, a large resistor value should be used to achieve better sensitivity; for a large light range, a small resistor value should be used to prevent non-linear output current and voltage.

### Resistor Output $R_{LOAD}$ Selection

The resistor output,  $R_{LOAD}$ , determines the voltage transfer function of the device. The device converts light into current then  $R_{LOAD}$  converts the output current to an output voltage.  $R_{LOAD}$  can range from 10 $\Omega$  to 10M $\Omega$  depending on the input lux levels. The table below lists  $R_{LOAD}$  values to maximize output swing for typical lux range levels. A careful balance of dynamic swing and fast response has to be considered when choosing  $R_{LOAD}$ . For faster response, choose a smaller value  $R_{LOAD}$  to shunt stray capacitances that may slow down response time. For maximum dynamic range or swing, choose a higher value  $R_{LOAD}$ . Although finite, the output impedance of the device is considerably large. Hence, the light-to-current conversion deviation because of resistor loading is infinitesimal. The recommended maximum  $R_{LOAD}$  is 10M $\Omega$ .

The output current must never exceed 6mA. When using load resistances less than 800 $\Omega$ , care must be taken when lux go as high as 10,000lux because the output current rises above 6mA before reaching the device's output compliance. The output compliance of the device is 300mV below the supply. The output current stops ramping when the output voltage reaches voltage compliance.

TABLE 1.  $V_{DD} = 5V$ , MAXIMUM OUTPUT VOLTAGE = 4.7V

ILLUMINATION RANGE (lux)	RLOAD (k $\Omega$ )	CURRENT OUT ( $\mu A$ )
0 to 10	783	0 to 6
0 to 200	39.2	0 to 120
0 to 500	15.7	0 to 300
0 to 1,000	7.8	0 to 600
0 to 10,000	0.78	0 to 6,000

### Application Examples

The following examples present from fully automatic to fully manual override implementations. These guidelines are applicable to a wide variety of potential light control applications. The EL7900 can be used to control the brightness input of CCFL inverters. Likewise, it can interface well with LED drivers. In each specific application, it is important to recognize the target environment and its ambient light conditions. The mechanical mounting of the sensor, light aperture hole size and use of a light pipe or bezel are critical in determining the response of the EL7900 for a given exposure of light.

The example in Figure 10 shows a fully automatic dimming solution with no user interaction. Choose  $R_1$  and  $R_2$  values for any desired minimum brightness and slope. Choose  $C_1$  to adjust response time and to filter 50/60Hz room lighting. For example, suppose you wish to generate an output voltage from 0.25V to 1.25V to drive the input of an LED driver controller. The 0.25V represents the minimum LED brightness and 1.25V represents the maximum. The first step would be to determine the ratio of  $R_1$  and  $R_2$ :

$$R_1 = R_2 \times \left( \frac{3.0V}{0.25V} - 1 \right) = 11 \times R_2 \quad (EQ. 4)$$

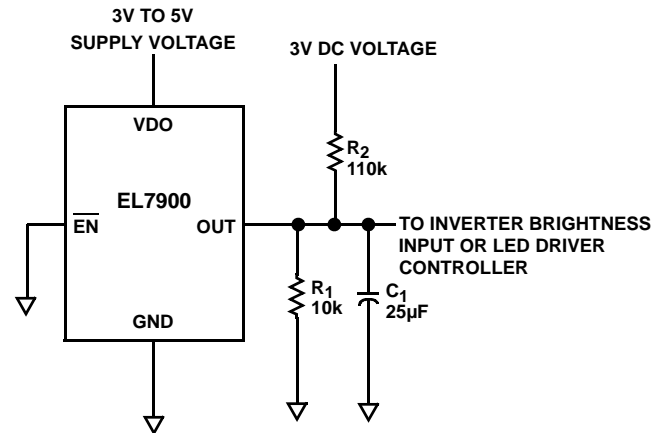

FIGURE 10. AUTOMATIC DIMMING SOLUTION

Next, the value of  $R_2$  can be calculated based on the maximum output current coming from the EL7900 under the application's maximum light exposure. Suppose the current has been determined to be about 125 $\mu A$ . Thus,  $R_2$  can be calculated approximately as follows:

$$R_2 = \left( \frac{1.25V}{125\mu A} \right) = 10k\Omega \quad (EQ. 5)$$

and

$$R_1 = 11 \times R_2 = 110k\Omega \quad (EQ. 6)$$

In Figure 11, user adjustable bias control has been added to allow control over the minimum and maximum output voltage. This allows the user to adjust the output brightness to personal preference over a limit range via the 3V PWM control.

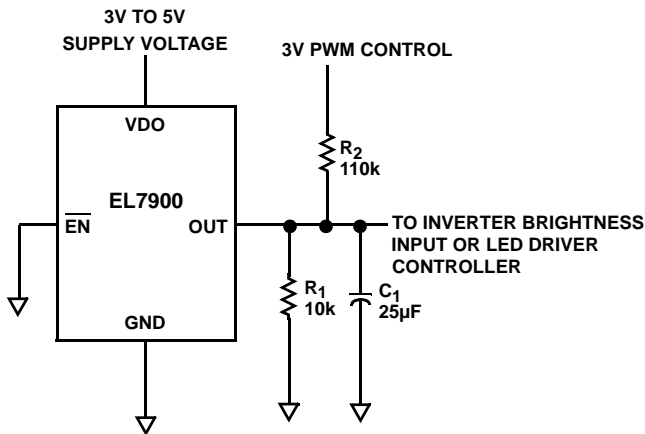

FIGURE 11. AUTOMATIC DIMMING SOLUTION WITH ADJUSTABLE BIAS CONTROL

Figure 12 shows how a fully manual override can be quickly added by using the  $\overline{\text{EN}}$  pin.

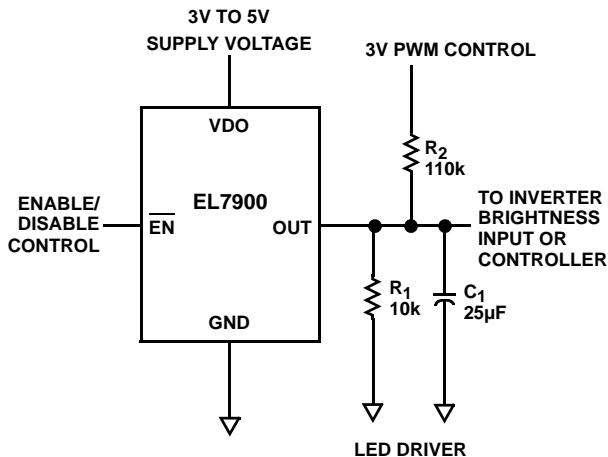

FIGURE 12. AUTOMATIC DIMMING SOLUTION WITH ADJUSTABLE BIAS CONTROL AND MANUAL OVERRIDE

**Short Circuit Current Limit**

The EL7900 does not limit the output short circuit current. If the output is directly shorted to the ground continuously, the output current could easily increase for a strong input light such that the device may be damaged. Maximum reliability is maintained if the output continuous current never exceeds 6mA by adding a load resistor at the output. This limit is set by the design of the internal metal interconnects.

**Suggested PCB Footprint**

Footprint pads should be a nominal 1-to-1 correspondence with package pads. The large, exposed central die-mounting paddle in the center of the package requires neither thermal nor electrical connections to PCB, and such connections should be avoided.

**Power Supply Bypassing and Printed Circuit Board Layout**

The EL7900 is relatively insensitive to the printed circuit board layout due to its low speed operation. Nevertheless, good printed circuit board layout is necessary for optimum performance. Ground plane construction is highly recommended, lead length should be as short as possible and the power supply pins must be well bypassed to reduce the risk of oscillation. For normal single supply operation, where the GND pin is connected to ground, a 0.1µF ceramic capacitor should be placed from VCC pin to GND pin. A 4.7µF tantalum capacitor should then be connected in parallel, placed close to the device.

All Intersil U.S. products are manufactured, assembled and tested utilizing ISO9000 quality systems. Intersil Corporation's quality certifications can be viewed at [www.intersil.com/design/quality](http://www.intersil.com/design/quality)

*Intersil products are sold by description only. Intersil Corporation reserves the right to make changes in circuit design, software and/or specifications at any time without notice. Accordingly, the reader is cautioned to verify that data sheets are current before placing orders. Information furnished by Intersil is believed to be accurate and reliable. However, no responsibility is assumed by Intersil or its subsidiaries for its use; nor for any infringements of patents or other rights of third parties which may result from its use. No license is granted by implication or otherwise under any patent or patent rights of Intersil or its subsidiaries.*

For information regarding Intersil Corporation and its products, see [www.intersil.com](http://www.intersil.com)

# Package Outline Drawing

## L5.2x2.1

5 LEAD OPTICAL DUAL FLAT NO-LEAD PLASTIC PACKAGE

Rev 0, 01/07

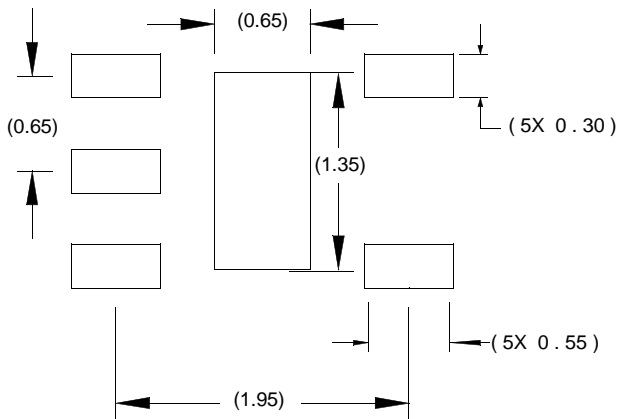
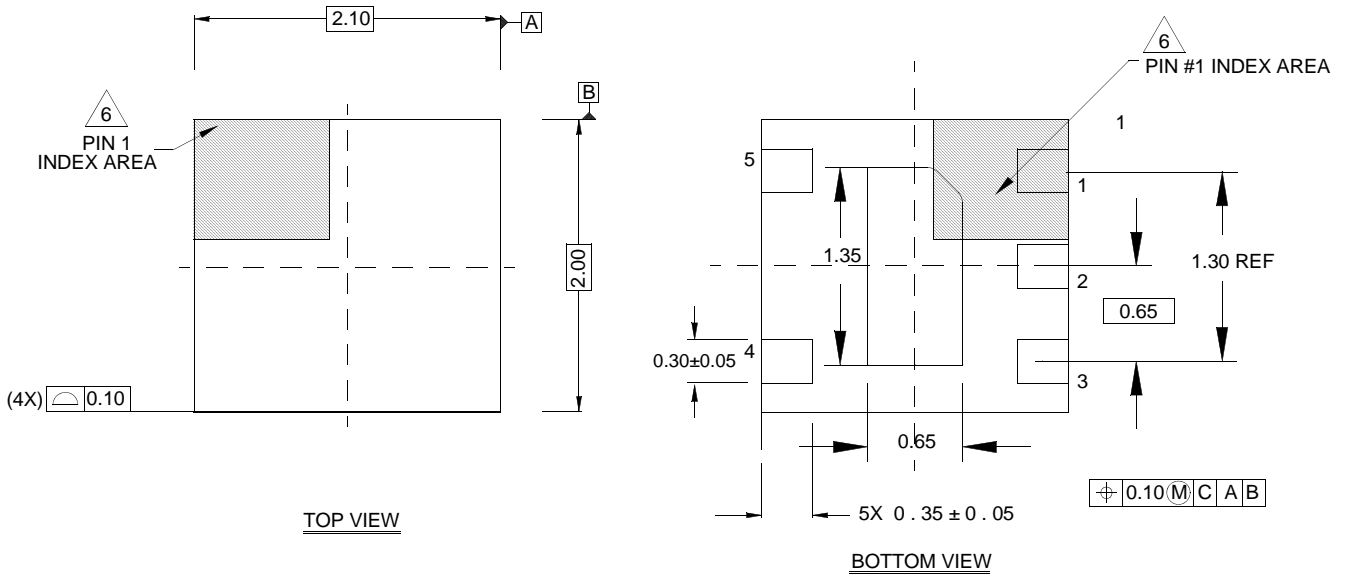

TYPICAL RECOMMENDED LAND PATTERN

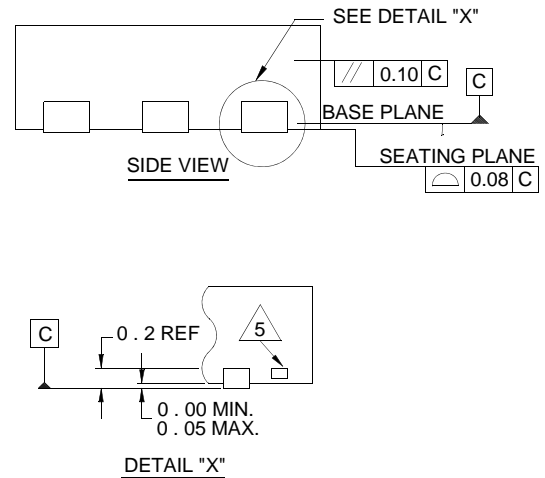

NOTES:

1. Dimensions are in millimeters.  
Dimensions in ( ) for Reference Only.
2. Dimensioning and tolerancing conform to AMSE Y14.5m-1994.
3. Unless otherwise specified, tolerance : Decimal  $\pm 0.05$
4. Dimension b applies to the metallized terminal and is measured between 0.15mm and 0.30mm from the terminal tip.
5. Tiebar shown (if present) is a non-functional feature.
6. The configuration of the pin #1 identifier is optional, but must be located within the zone indicated. The pin #1 identifier may be either a mold or mark feature.