

SCHOTTKY BARRIER RECTIFIER

VOLTAGE RANGE: 20 --- 200 V
CURRENT: 20.0A

FEATURES

- ◇ Metal-semiconductor junction with guard ring
- ◇ Epitaxial construction
- ◇ Low forward voltage drop, low switching losses
- ◇ High surge capability
- ◇ For use in low voltage, high frequency inverters free wheeling, and polarity protection applications
- ◇ The plastic material carries U/L recognition 94V-0

MECHANICAL DATA

- ◇ Case: JEDEC TO-220AB, molded plastic
- ◇ Terminals: Axial lead, solderable per MIL-STD-750, Method 2026
- ◇ Polarity: As marked
- ◇ Weight: 0.08 ounces, 2.24 grams
- ◇ Mounting position: Any

TO - 220AB

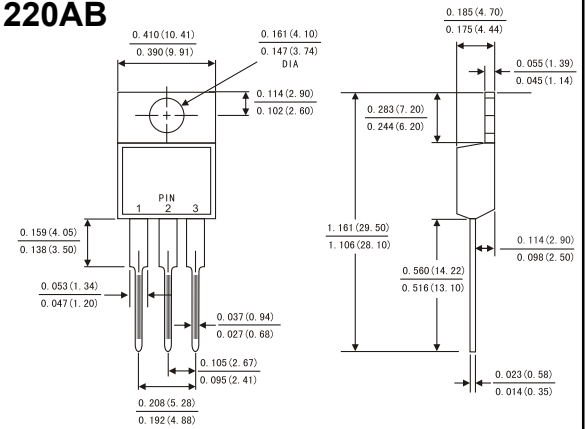

MAXIMUM RATINGS AND ELECTRICAL CHARACTERISTICS

Ratings at 25°C ambient temperature unless otherwise specified.

Single phase, half wave, 60 Hz, resistive or inductive load. For capacitive load, derate by 20%.

	Symbols	MBR 2020CT	MBR 2030CT	MBR 2040CT	MBR 2050CT	MBR 2060CT	MBR 2080CT	MBR 20A0CT	MBR 20150CT	MBR 20200CT	Units
Maximum repetitive peak reverse voltage	V _{RRM}	20	30	40	50	60	80	100	150	200	Volts
Maximum RMS voltage	V _{RMS}	14	21	28	35	42	56	70	105	140	Volts
Maximum DC blocking voltage	V _{DC}	20	30	40	50	60	80	100	150	200	Volts
Maximum average forward rectified current (see Fig. 1)	Per leg	10.0									Amps
	Total device	20.0									
Peak forward surge current 8.3ms single half sine-wave superimposed on rated load (JEDEC method)	I _{FSM}	200.0									Amps
Maximum instantaneous forward voltage at 20.0 A	V _F	0.60		0.75		0.85		0.90		0.95	Volts
Maximum instantaneous reverse current at rated DC blocking voltage (Note 1)	T _c = 25°C	0.2									mA
	T _c = 125°C	30			50						
Typical thermal resistance (Note 2)	R _{θJC}	3.0									°C/W
Operating junction temperature range	T _J	-65 to +150									°C
Storage temperature range	T _{STG}	-65 to +150									°C

- NOTE: 1. Pulse test: 300us pulse width, 1% duty cycle.
2. Measured at 1.0MHz and applied reverse voltage of 4.0V DC.
3. Thermal resistance junction to ambient

FIG.1-FORWARD CURRENT DERATING CURVE

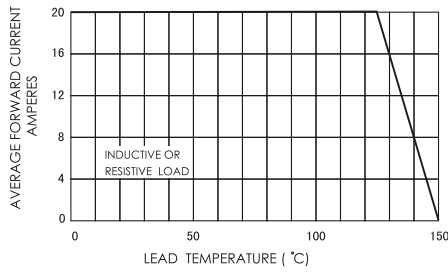

FIG.2-MAXIMUM NON-REPETITIVE PEAK FORWARD SURGE CURRENT

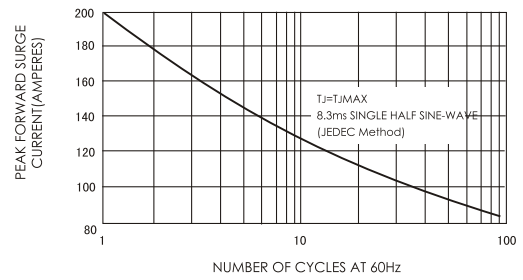

FIG.3-TYPICAL INSTANTANEOUS FORWARD CHARACTERISTICS

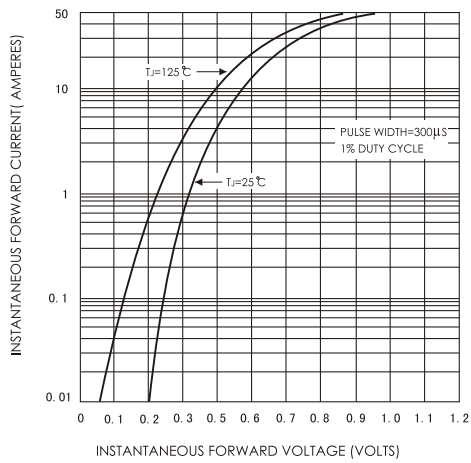

FIG.4-TYPICAL REVERSE CHARACTERISTICS

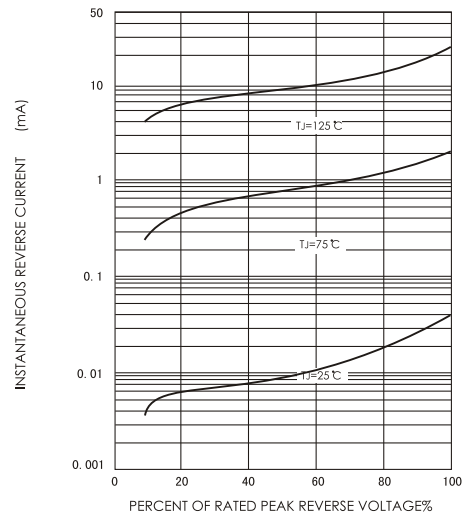

FIG.5-TYPICAL JUNCTION CAPACITANCE

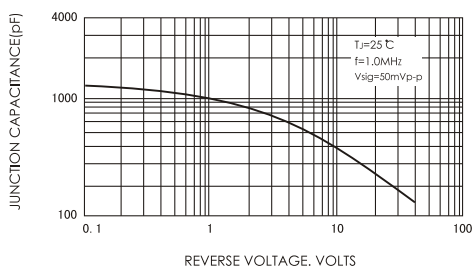

FIG.6-TYPICAL TRANSIENT THERMAL IMPEDANCE

