

ATLANTIC VERSION TERMINATOR INTERFACE ADAPTER	PART NUMBER	REVISION	DESCRIPTION	FEED TYPE	CONVERT TO	PART NUMBERS REQUIRED					
	2266047-1	C	FINE CRIMP HEIGHT ADJUST	MECHANICAL	PNEUMATIC FEED	2119950-1	1338685-1	5-18022-5	2119641-1	2119799-1	2063440-1
	2266047-2	C	FINE CRIMP HEIGHT ADJUST	PNEUMATIC	SERVO LATCH PLATE	2119951-1	-	8-2266047-5	1901094-3	-	2168400-6 (QUANTITY 2)
					SMART APPLICATOR	2161326-1	-	8-2266047-4	-	-	
					MECHANICAL FEED	2119949-1	1338685-1	5-18022-5	2119653-1	-	-
	2266047-5	C	FINE CRIMP HEIGHT ADJUST	SERVO LATCH PLATE <sup>4</sup>	SERVO LATCH PLATE	2119951-1	-	8-2266047-5	1901094-3	-	2168400-6 (QUANTITY 2)
					SMART APPLICATOR	2161326-1	-	8-2266047-4	-	-	
	2266047-6	C	NON-CRIMP HEIGHT ADJUST	SERVO LATCH PLATE <sup>4</sup>	SERVO LATCH PLATE <sup>12</sup>	MECHANICAL FEED	2119949-1	1338685-1	5-18022-5	2119653-1	-
PNEUMATIC FEED						2119950-1	1338685-1	5-18022-5	2119641-1	2119799-1	2063440-1
2266047-7	C	FINE CRIMP HEIGHT ADJUST	NONE	-	-	-	-	-	-	-	-
7-2266047-7	C	CRIMP TOOLING KIT	-	-	-	-	-	-	-	-	-

APPLICATOR DATA		
CRIMP	SIZE	TYPE
WIRE	1.17 mm [.046]	F
INSUL	-	-

APPLICATOR INSTRUCTIONS  
408-10389

TERMINAL DATA: TE TERMINAL		TE CRIMP SPECIFICATION	
TERMINAL NAME: CENTER CONTACT, 180 DEGREE, FAKRA			
WIRE STRIP LENGTH		INSULATION DIAMETER RANGE	
2.86-3.80 mm [.113-.150 IN]		Ø1.49-1.65 mm [.059-.065 IN]	
TERMINAL APPLICATION SPECIFICATION	114-32145	-	-
TERMINALS APPLIED			
TE TERMINAL	TE TERMINAL	TE TERMINAL	TE TERMINAL
1-2203260-3	2203260-6	1-2203270-3	2203270-6

WIRE SIZE	CRIMP HEIGHT mm [INCH]	CRIMP HEIGHT REFERENCE SETTING
RG-59	0.81+/-0.03 [.032+/-0.001]	9.6
RG-71	0.80+/-0.03 [.031+/-0.001]	9.7
RG-62	0.80+/-0.03 [.031+/-0.001]	9.7

- RECOMMENDED SPARE PARTS
- GREASE BEARING SURFACES LIGHTLY
- 3. LUBRICATE DAILY PER THE APPLICATOR INSTRUCTION SHEET SUPPLIED WITH THE APPLICATOR.
- APPLICATOR SPECIFIC DATA TO BE ENTERED INTO BLANK MEMORY CHIP AT ASSEMBLY. SEE BELOW FOR PART NUMBER:  
 MECHANICAL FEED WITH "SMART APPLICATOR" CONVERSION: 8-2266047-4  
 PNEUMATIC FEED WITH "SMART APPLICATOR" CONVERSION: 8-2266047-4  
 SERVO FEED WITH "FINE CRIMP HEIGHT ADJUST": 8-2266047-5  
 SERVO FEED WITH "NON-CRIMP HEIGHT ADJUST": 8-2266047-6
- 5. ADJUSTMENT OF THE STRIPPER MAY BE REQUIRED WHEN MOVING THE APPLICATOR BETWEEN BENCH AND LEADMAKER APPLICATIONS.
- APPLY PART NUMBER 1-23419-5 LOCTITE TO THREADS OF ITEM 62. FOR -6 ONLY APPLY PART NUMBER 1-23419-5 LOCTITE TO THREADS OF ITEM 37.
- GREASE THREADS, GROOVE AND O-RING ON ITEMS 35 & 252.
- MAGNET, ITEM 166 MUST BE ORIENTED CORRECTLY IN ORDER TO PROPERLY ACTUATE THE COUNTER.
- CRIMP HEIGHT REFERENCE SETTING WAS THE SETTING USED WHEN THE APPLICATOR WAS QUALIFIED AT THE FACTORY. ADJUSTMENT MAY BE NECESSARY WHEN RUNNING APPLICATOR IN THE FIELD.
- SPARE FEED CAM STORAGE LOCATION REFER TO INSTRUCTION SHEET FOR ADDITIONAL INFORMATION.
- TO CONVERT THE APPLICATOR TO A NON-CARRIER CUTTING STYLE, REMOVE ITEM 13 AND ATTACH TO THE LOCATION ON THE BACK SIDE OF THE HOUSING. REFER TO INSTRUCTION SHEET FOR ADDITIONAL INFORMATION.
- WHEN ASSEMBLING A NON CRIMP HEIGHT ADJUST APPLICATOR (-6) USE SHIMS FROM ITEM 260 TO ACHIEVE A NOMINAL SHIM HEIGHT OF 4.99.

**\*WARNING**  
ON INSTALLATION, SET WIRE DISC, ITEM 40 TO LARGEST WIRE SIZE SETTING. USE OF SETTINGS BELOW MINIMUM REQUIRED CRIMP HEIGHT SETTING WILL CAUSE DAMAGE TO CRIMP TOOLING.

	-	-	1	-	-	-	2119957-2	APPLICATOR SHIM PACK	260
	-	1	-	1	1	1	8-21084-0	O-RING, .676 ID, .070 DIA. MAT.	252
	-	-	-	-	1	-	2119640-1	PUSH ROD, AIR FEED	250
	-77	-7	-6	-5	-2	-1	PART NO	DESCRIPTION	ITEM NO

**ATLANTIC VERSION**  
Shown on sheets 1 of 4 & 2 of 4  
(Pacific version shown on sheets 3 of 4 & 4 of 4)

SET UP GAUGE	LOC	DIST	REVISIONS					
2119599-1	A	66	P	LTN	DESCRIPTION	DATE	OWN	APVD
			A		RELEASED	12JAN2016	MR	TE
			A1		ECR-16-010040	18JUL2016	RS	LZ
			B		ECR-16-014511	13OCT2016	JH	TE
			C		ECR-17-000398	11JAN2017	MZ	KZ

-	-	-	-	1	-	2079988-1	BUSHING, LCH5-12, MISUMI	249	
-	-	-	-	1	-	2119641-1	FEED CAM, AIR FEED	248	
-	1	-	1	1	1	2119798-1	DETENT PIN	247	
-	1	-	1	1	1	1-22279-3	SPRING, COMPRESSION	246	
-	-	1	-	-	-	2119758-1	RAM, AMP STYLE, SIDE FEED, NON-ADJ.	245	
-	1	1	1	1	1	7-18023-7	SCR, SKT HD CAP M3 X 4.0	241	
-	-	2	2	-	-	2168400-6	SHCS, LOW HEAD, RoHS, M5 X 16	240	
-	-	-	-	-	1	2119580-1	MECHANICAL FEED ASSEMBLY	239	
-	-	-	-	-	1	2063440-1	AIR FEED MODULE	238	
-	-	1	1	-	-	2119740-2	TAG, IDENTIFICATION	213	
-	-	1	1	-	-	1901094-3	SPACER, FEEDER	198	
-	-	-	-	2	-	21045-3	RING, RETAIN, EXTERN, 3/16 CRESCENT	172	
	-	1	1	1	1	994969-1	MAGNET, RARE EARTH HIGH ENERGY	166	
-	REF	REF	REF	REF	REF	994970-2	COUNTER, MAGNETIC	164	
-	-	-	-	1	-	240638-1	SPRING, FEED FINGER	163	
-	-	-	-	-	1	3-23627-7	PIN, RETAIN, GRVD, 3/16 X .854	137	
-	-	-	-	-	1	2119799-1	HOLDER, FEED FINGER, AF	136	
-	-	REF	REF	-	-	SEE NOTE 4	MEMORY CHIP, PROGRAMMED	135	
-	-	1	1	-	-	1633743-1	SERVO FEED LATCH ASM	133	
-	1	1	1	1	1	1-18028-2	WASHER, FLAT, REG M4	119	
-	-	REF	REF	-	-	2119944-1	FEED FINGER ASSEMBLY, SF	117	
-	1	1	1	1	1	455888-4	SPACER, CRIMPER	82	
-	1	1	1	1	1	22278-7	SPRING, COMPRESSION	77	
-	1	1	1	1	1	854769-4	HOLDER, INS	74	
-	1	1	1	1	1	2119956-1	DOCUMENTATION PACKAGE	71	
-	1	-	-	-	1	2119740-1	TAG, IDENTIFICATION	67	
-	2	2	2	2	2	2168078-1	SCREW, DRIVE, RH, RoHS, 2 x .188	66	
	-	1	-	1	1	2119793-1	LIMITER, ADJUSTMENT BOLT	63	
-	3	-	3	3	3	992763-5	SCR, SET, SOC, CONE POINT, M3 x 4.0	62	
-	1	1	1	1	1	2079383-4	SCR, BHSC, RoHS (M4 X 8)	60	
-	-	-	-	-	1	5-18022-5	SCR, HEX HD CAP, M4 X 6.0	59	
-	1	1	1	1	1	21028-2	PIN, SLOTTED SPRING .062 X .250	58	
-	-	-	-	-	1	1338685-1	PAWL, FEED	56	
-	4	4	4	4	4	2168400-1	SHCS, LOW HEAD, RoHS, M4 X 12	54	
-	2	2	2	2	2	1-2168083-0	SCR, SKT HD CAP, RoHS, M4 X 10	53	
-	1	1	1	1	1	5018030-1	NUT, HEX, REG, RoHS, M3	52	
-	1	1	1	1	1	811242-5	BUMPER, HOLD DOWN	51	
-	1	1	1	1	1	690753-6	SPACER, TONKER	50	
-	-	-	-	-	1	2	18023-9	SCR, SKT HD CAP M4 X 6.0	49
-	-	-	-	-	-	1	2119652-1	FEED CAM, PRE FEED	48
-	-	-	-	-	-	1	2119653-1	FEED CAM, POST FEED	47
-	1	1	1	1	1	2119656-9	APPLICATOR BASIC ASSEMBLY, SF	46	
-	1	-	-	-	1	1	2119370-1	RAM, AMP STYLE, SIDE FEED	44
-	1	1	1	1	1	2079383-7	SCR, BHSC, RoHS (M8 X 25)	41	
-	1	-	-	-	1	1	2119645-1	DISC, NUMBERED FA WIRE ADJUSTMENT	40
-	1	-	-	-	1	1	2119957-1	APPLICATOR SHIM PACK	39
-	1	1	1	1	1	2119644-1	RAM WASHER, PRECISION	38	
	-	1	1	1	1	1	2119085-1	FA HEAD, ATLANTIC STYLE	37
	-	1	-	-	1	1	2119092-1	BOLT, ADJUSTMENT	35
-	1	1	1	1	1	2-1752356-6	SUPPORT, TERMINAL	34	
-	2	2	2	2	2	2079383-5	SCR, BHSC, RoHS (M4 X 20)	33	
-	1	1	1	1	1	2161328-1	HEX HEAD, FLANGED, M5 x 8mm LONG	32	
-	1	1	1	1	1	1320908-2	SPACER, STRIP GUIDE	30	
-	1	1	1	1	1	2119959-1	ASSEMBLY, STRIP GUIDE	29	
-	1	1	1	1	1	455888-3	SPACER, CRIMPER	28	
-	1	1	1	1	1	1320928-2	STRIP GUIDE	24	
-	1	1	1	1	1	2168083-2	SCR, SKT HD CAP, RoHS, M4 X 8.0	21	
-	1	1	1	1	1	1-18028-2	WASHER, FLAT, REG M4	20	
-	1	1	1	1	1	2119533-3	STRIPPER, SIDE FEED	19	
	-	1	1	1	1	1	2119806-1	INSERT, SHEAR	13
-	1	1	1	1	1	1	5-22279-1	SPRING, COMPRESSION	12
-	1	1	1	1	1	1	1-356885-4	STOP, SHEAR	11
	-	1	1	1	1	1	2119805-1	SHEAR HOLDER, FRONT	10
	-	1	1	1	1	1	1803418-1	FLOATING SHEAR, MINI COAX FRONT	9
	1	1	1	1	1	1	1803190-6	ANVIL, COMBINATION	8
-	-	-	-	-	-	-	-	-	7
-	-	-	-	-	-	-	-	-	6
-	1	1	1	1	1	1	1803349-1	DEPRESSOR, SHEAR	5
-	-	-	-	-	-	-	-	-	4
-	-	-	-	-	-	-	-	-	3
-	-	-	-	-	-	-	-	-	2
	1	1	1	1	1	1	5-1333281-8	CRIMPER, WIRE PREMIUM	1
	-77	-7	-6	-5	-2	-1	PART NO	DESCRIPTION	ITEM NO

DIMENSIONS:		TOLERANCES UNLESS OTHERWISE SPECIFIED:		MATERIAL:		FINISH:		WEIGHT:		CUSTOMER DRAWING:	
mm	0 PLC	±									
	1 PLC	±									
	2 PLC	±									
	3 PLC	±									
	4 PLC	±									
	ANGLES	±									

LOC		DIST		REVISIONS			
A	66	P	LTN	DESCRIPTION	DATE	DWN	APVD
		-		SEE SHEET 1			

### FEED TYPE MECHANICAL

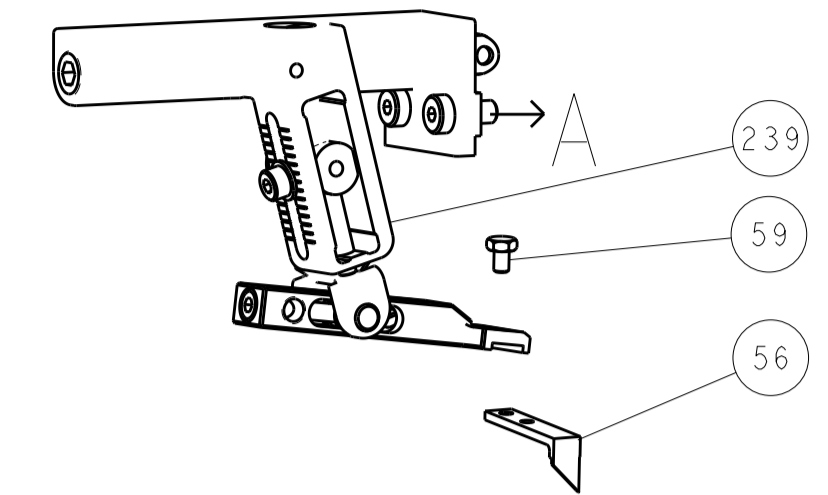

### PNEUMATIC

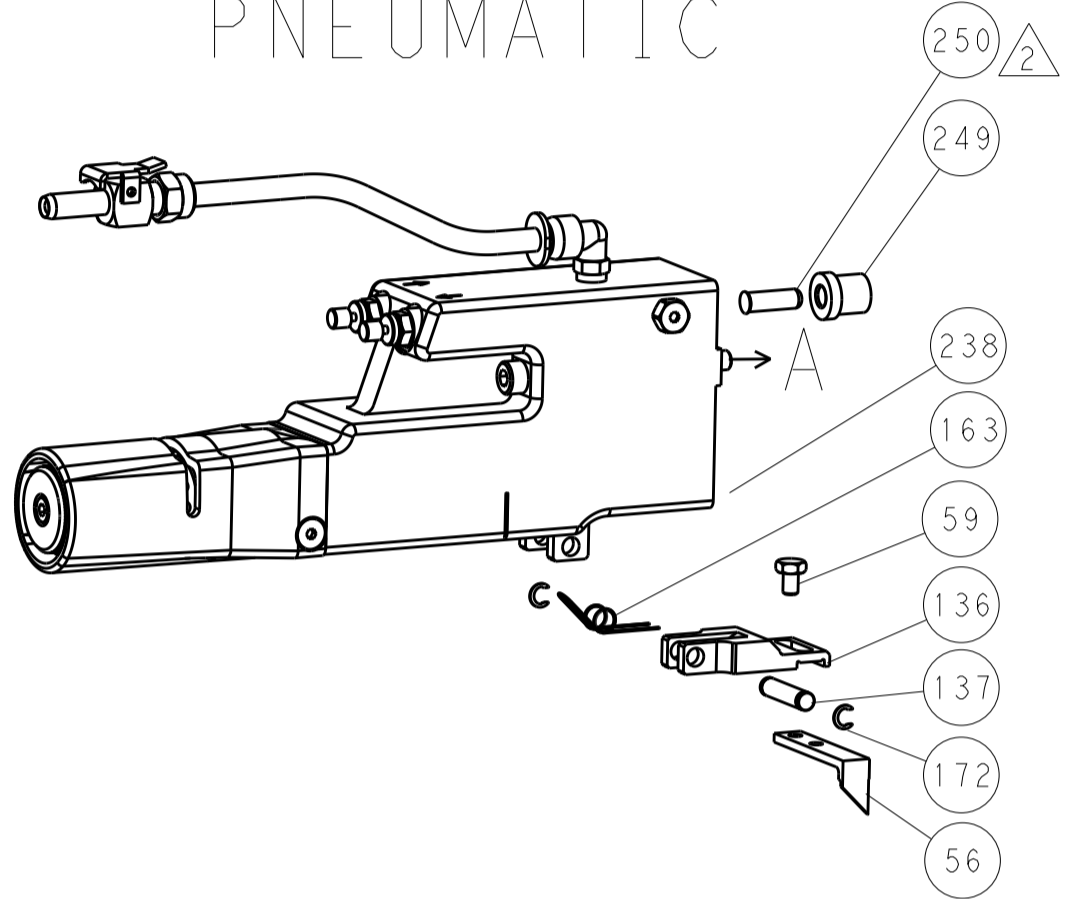

### SERVO LATCH PLATE

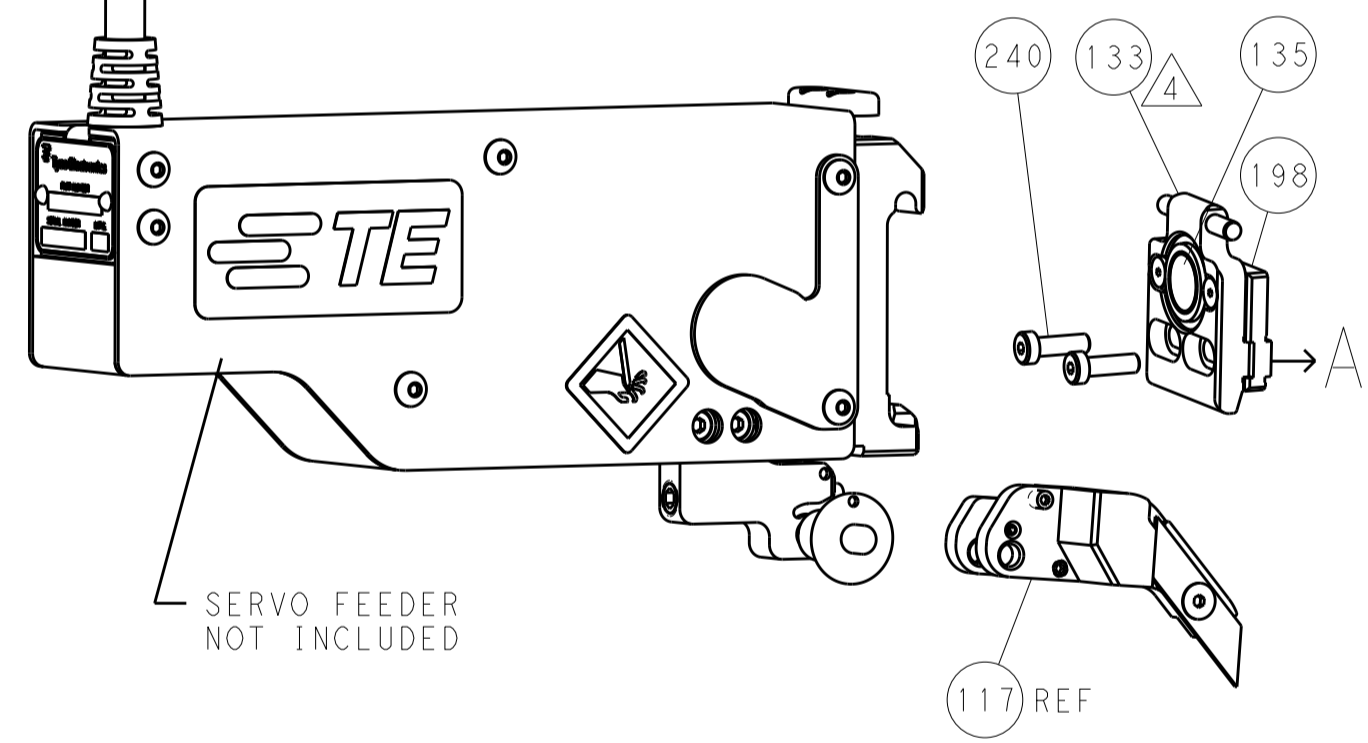

### CAM POSITIONS

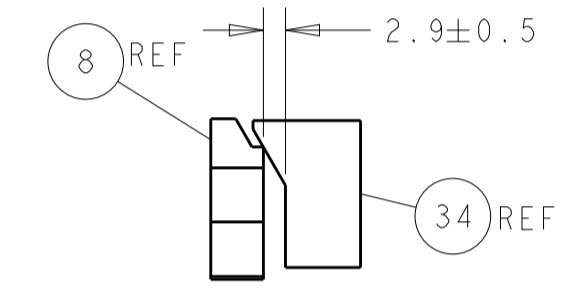
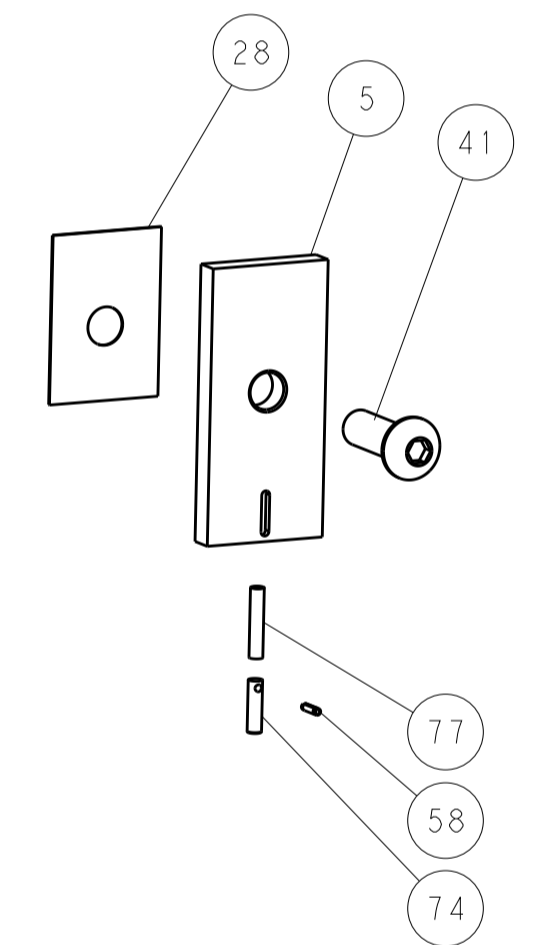
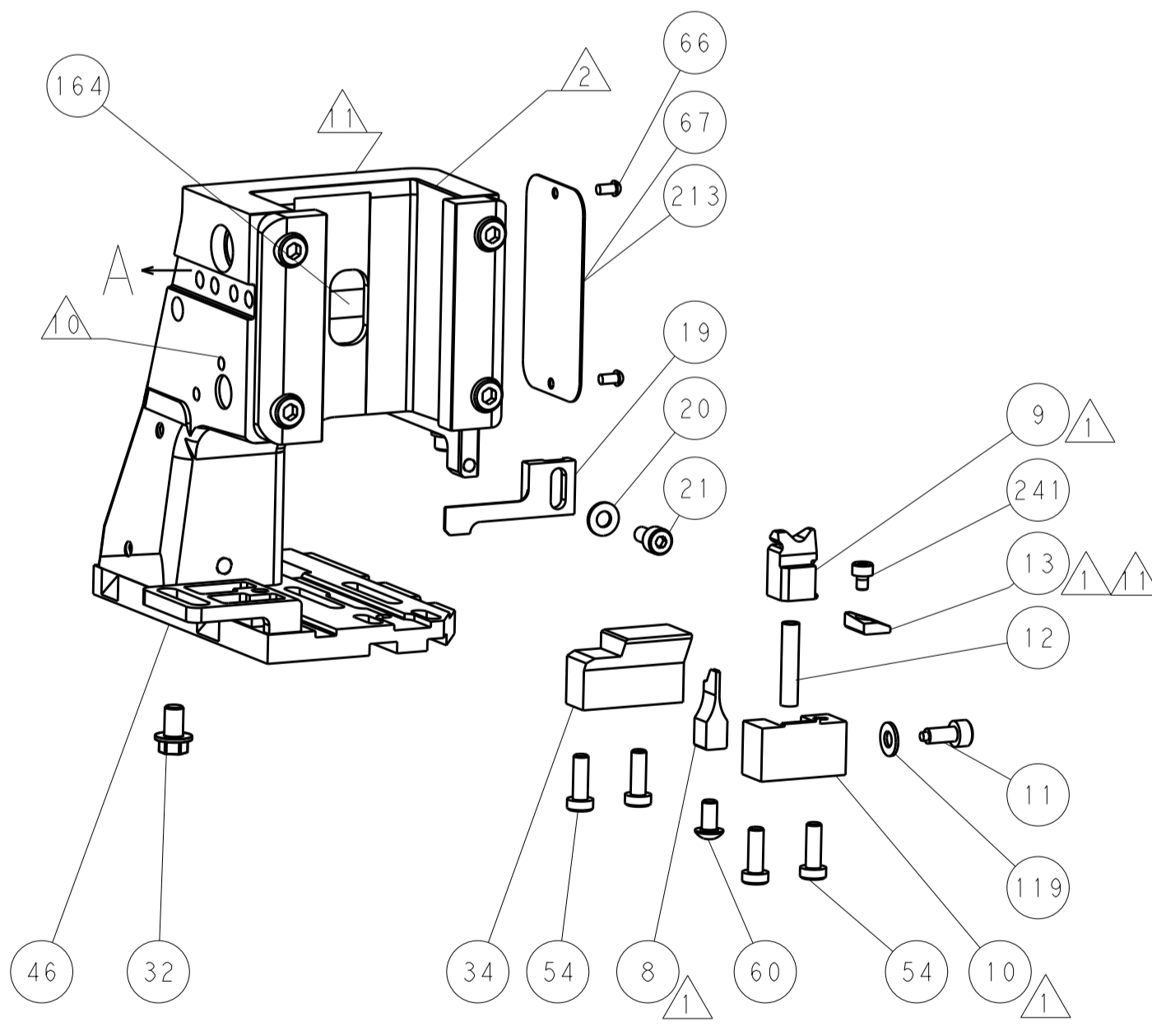
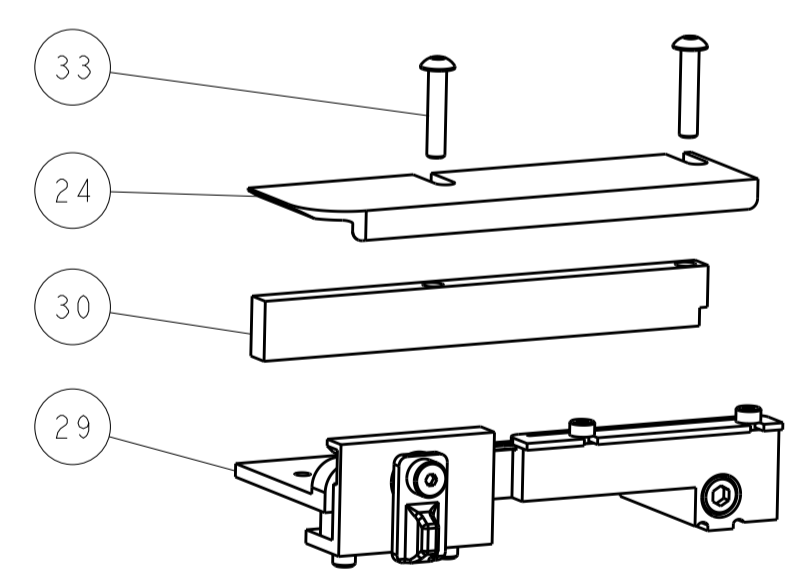
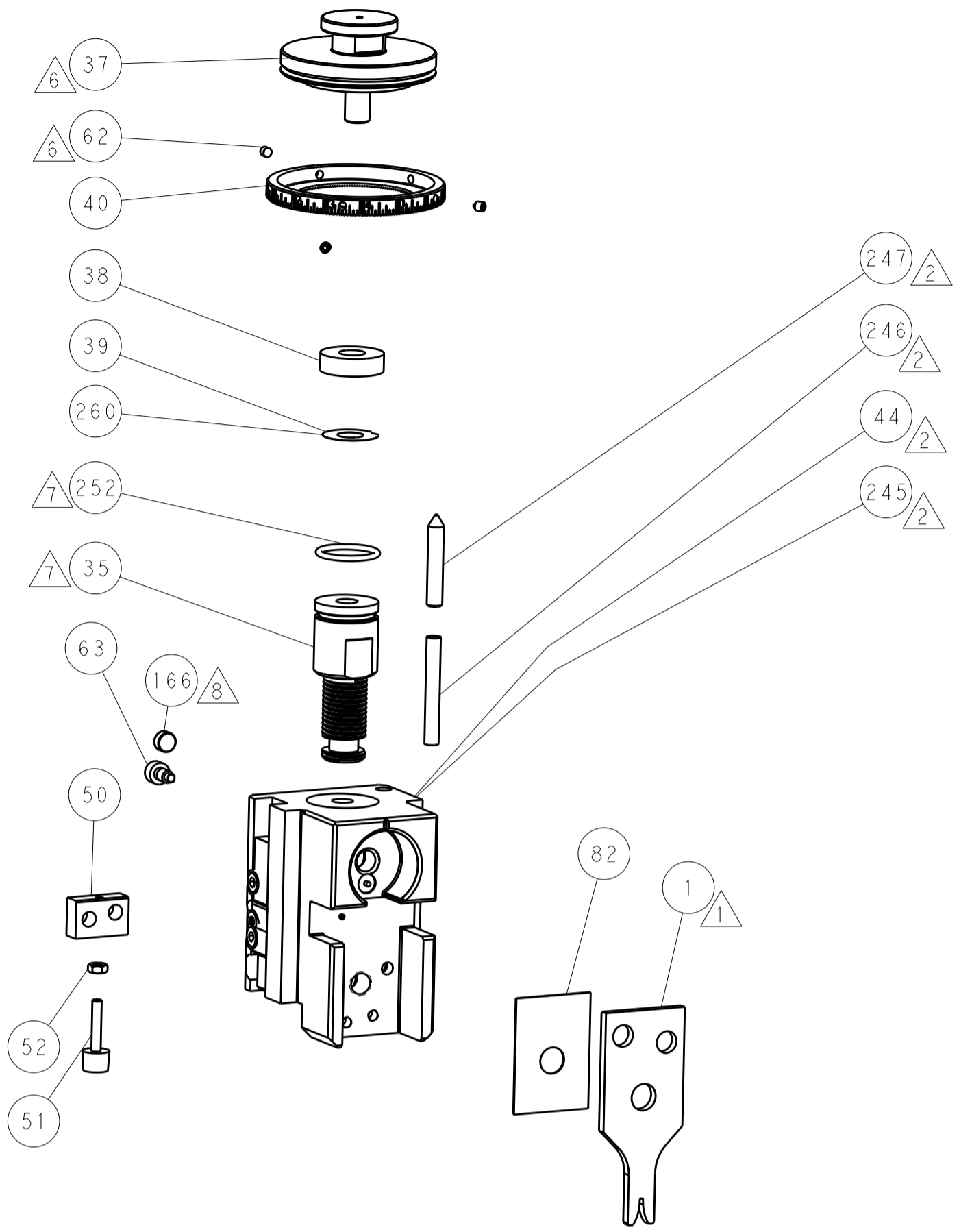
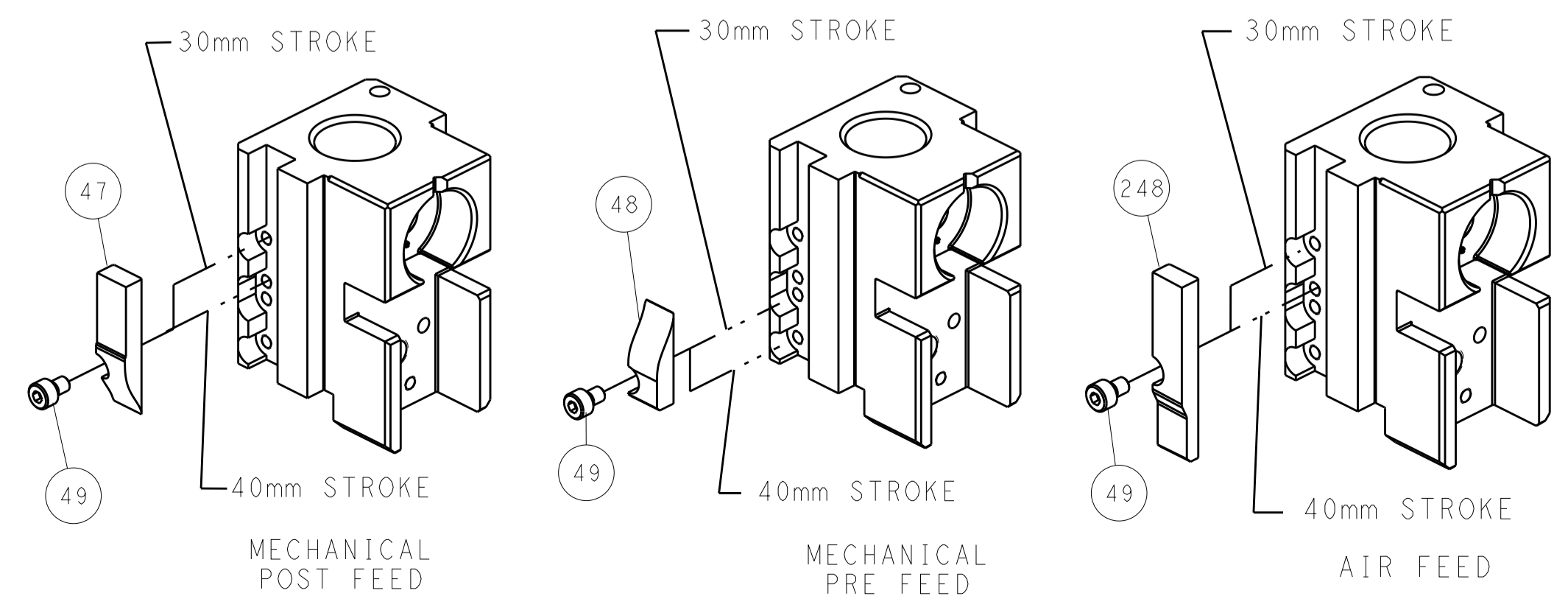

TERMINAL SUPPORT LOCATION

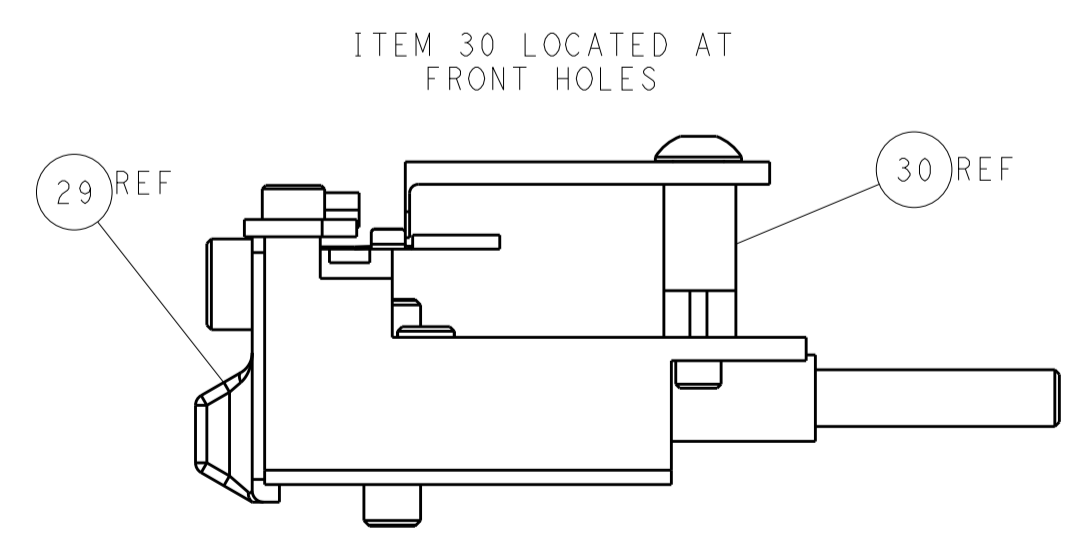

FEED TRACK POSITION GUIDE BY WIRE BARREL

**ATLANTIC VERSION**  
 Shown on sheets 1 of 4 & 2 of 4  
 (Pacific version shown on sheets 3 of 4 & 4 of 4)

DIMENSIONS:		TOLERANCES UNLESS OTHERWISE SPECIFIED:		DWN R.O. WILSON 18OCT2013		TE Connectivity	
mm	0 PLC ±	1 PLC ±	2 PLC ±	3 PLC ±	4 PLC ±	Harrisburg, PA 17105-3608	
MATERIAL:		FINISH:		APVD J.J. STAKEM 21OCT2013		NAME Ocean Side Feed Applicator	
				PRODUCT SPEC		SIZE CAGE CODE DRAWING NO RESTRICTED TO	
				APPLICATION SPEC		A1 00779 C=2266047	
				WEIGHT		SCALE 1:2 SHEET 2 OF 4 REV C	
				CUSTOMER DRAWING			

PACIFIC VERSION TERMINATOR INTERFACE ADAPTER	PART NUMBER	REVISION	DESCRIPTION	FEED TYPE	APPLICATOR STYLE CONVERSION CHART						
					CONVERT TO	PART NUMBERS REQUIRED					
	2-2266047-1	C	FINE CRIMP HEIGHT ADJUST	MECHANICAL	PNEUMATIC FEED	2119950-1	1338685-1	5-18022-5	2119641-2	2119799-1	2063440-1
					SERVO LATCH PLATE	2119951-1	-	8-2266047-5	1901094-3	-	2168400-6 (QUANTITY 2)
					SMART APPLICATOR	2161326-1	-	8-2266047-4	-	-	-
	2-2266047-2	C	FINE CRIMP HEIGHT ADJUST	PNEUMATIC	MECHANICAL FEED	2119949-1	1338685-1	5-18022-5	2119653-2	-	-
					SERVO LATCH PLATE	2119951-1	-	8-2266047-5	1901094-3	-	2168400-6 (QUANTITY 2)
					SMART APPLICATOR	2161326-1	-	8-2266047-4	-	-	-
	2-2266047-5	C	FINE CRIMP HEIGHT ADJUST	SERVO LATCH PLATE <sup>4</sup>	MECHANICAL FEED	2119949-1	1338685-1	5-18022-5	2119653-2	-	-
					PNEUMATIC FEED	2119950-1	1338685-1	5-18022-5	2119641-2	2119799-1	2063440-1
	2-2266047-7	C	FINE CRIMP HEIGHT ADJUST	NONE	-	-	-	-	-	-	-
	7-2266047-7	C	CRIMP TOOLING KIT	-	-	-	-	-	-	-	-

APPLICATOR DATA		
CRIMP	SIZE	TYPE
WIRE	1.17 mm [.046]	F
INSUL	-	-
APPLICATOR INSTRUCTIONS 408-10389		

TERMINAL DATA: TE TERMINAL		TE CRIMP SPECIFICATION	
TERMINAL NAME: CENTER CONTACT, 180 DEGREE, FAKRA			
WIRE STRIP LENGTH		INSULATION DIAMETER RANGE	
2.86-3.80 mm [.113-.150 IN]		Ø1.49-1.65 mm [.059-.065 IN]	
TERMINAL APPLICATION SPECIFICATION	114-32145	-	-
TERMINALS APPLIED			
TE TERMINAL	TE TERMINAL	TE TERMINAL	TE TERMINAL
1-2203260-3	2203260-6	1-2203270-3	2203270-6

WIRE SIZE	CRIMP HEIGHT WI_CRIMP_UNITS	CRIMP HEIGHT <sup>9</sup> REFERENCE SETTING
RG-59	0.81+/-0.03 [.032+/-0.001]	9.6
RG-71	0.80+/-0.03 [.031+/-0.001]	9.7
RG-62	0.80+/-0.03 [.031+/-0.001]	9.7

- RECOMMENDED SPARE PARTS
- GREASE BEARING SURFACES LIGHTLY
- 3. LUBRICATE DAILY PER THE APPLICATOR INSTRUCTION SHEET SUPPLIED WITH THE APPLICATOR.
- 4. APPLICATOR SPECIFIC DATA TO BE ENTERED INTO BLANK MEMORY CHIP AT ASSEMBLY. SEE BELOW FOR PART NUMBER:  
 MECHANICAL FEED WITH "SMART APPLICATOR" CONVERSION: 8-2266047-4  
 PNEUMATIC FEED WITH "SMART APPLICATOR" CONVERSION: 8-2266047-4  
 SERVO FEED WITH "FINE CRIMP HEIGHT ADJUST": 8-2266047-5
- 5. ADJUSTMENT OF THE STRIPPER MAY BE REQUIRED WHEN MOVING THE APPLICATOR BETWEEN BENCH AND LEADMAKER APPLICATIONS.
- 6. APPLY PART NUMBER 1-23419-5 LOCTITE TO THREADS OF ITEM 62.
- 7. GREASE THREADS, GROOVE AND O-RING ON ITEMS 139 & 152.
- 8. MAGNET MUST BE ORIENTED CORRECTLY IN ORDER TO PROPERLY ACTUATE THE COUNTER.
- 9. CRIMP HEIGHT REFERENCE SETTING WAS THE SETTING USED WHEN THE APPLICATOR WAS QUALIFIED AT THE FACTORY. ADJUSTMENT MAY BE NECESSARY WHEN RUNNING APPLICATOR IN THE FIELD.
- 10. SPARE FEED CAM STORAGE LOCATION REFER TO INSTRUCTION SHEET FOR ADDITIONAL INFORMATION.
- 11. TO CONVERT THE APPLICATOR TO A NON-CARRIER CUTTING STYLE, REMOVE ITEM 13 AND ATTACH TO THE LOCATION ON BACK SIDE OF THE HOUSING. REFER TO INSTRUCTION SHEET FOR ADDITIONAL INFORMATION.

**\*WARNING**  
 ON INSTALLATION, SET WIRE DISC, ITEM 40 TO LARGEST WIRE SIZE SETTING. USE OF SETTINGS BELOW MINIMUM REQUIRED CRIMP HEIGHT SETTING WILL CAUSE DAMAGE TO CRIMP TOOLING.

**PACIFIC VERSION**  
 Shown on sheets 3 of 4 & 4 of 4  
 (Atlantic version shown on sheets 1 of 4 & 2 of 4)

SET UP GAUGE	LOC	DIST	REVISIONS			
2119599-1	A	66	REV	DATE	BY	APPD
-	-	-	SEE SHEET 1	-	-	-

-	1	1	1	1	2119782-1	FINE ADJUST HEAD ASM, PACIFIC STYLE	251	
-	-	-	1	-	2119640-1	PUSH ROD, AIR FEED	250	
-	-	-	1	-	2079988-1	BUSHING, LCH5-12, MISUMI	249	
-	1	1	1	1	1-22279-3	SPRING, COMPRESSION	246	
-	1	1	1	1	7-18023-7	SCR, SKT HD CAP M3 X 4.0	241	
-	-	2	-	-	2168400-6	SHCS, LOW HEAD, RoHS, M5 X 16	240	
-	-	-	-	1	2119580-1	MECHANICAL FEED ASSEMBLY	239	
-	-	-	1	-	2063440-1	AIR FEED MODULE	238	
-	-	1	-	-	2119740-2	TAG, IDENTIFICATION	213	
-	-	1	-	-	1901094-3	SPACER, FEEDER	198	
-	-	-	2	-	21045-3	RING, RETAIN, EXTERN, 3/16 CRESCENT	172	
	1	1	1	1	994969-1	MAGNET, RARE EARTH HIGH ENERGY	166	
-	REF	REF	REF	REF	994970-2	COUNTER, MAGNETIC	164	
-	-	-	1	-	240638-1	SPRING, FEED FINGER	163	
	1	1	1	1	8-21084-1	O-RING, .801 ID, .070 DIA. MAT.	152	
-	-	-	1	-	2119641-2	FEED CAM, AIR FEED	151	
-	1	1	1	1	2119798-2	DETENT PIN	145	
-	1	1	1	1	2079383-8	SCR, BHSC, RoHS (M4 X 16)	144	
-	4	4	4	4	2168400-5	SHCS, LOW HEAD, RoHS, M4 X 20	143	
-	-	-	-	1	2119653-2	FEED CAM, POST FEED	142	
-	1	1	1	1	1-2119656-0	APPLICATOR BASIC ASSEMBLY, SF	141	
-	1	1	1	1	2119650-1	RAM, ASIAN STYLE, SIDE FEED	140	
	1	1	1	1	2119092-2	BOLT, ADJUSTMENT	139	
-	-	-	1	-	3-23627-7	PIN, RETAIN, GRVD, 3/16 X .854	137	
-	-	-	1	-	2119799-1	HOLDER, FEED FINGER, AF	136	
-	-	REF	-	-	-	SEE NOTE 4	MEMORY CHIP, PROGRAMMED	135
-	-	1	-	-	1633743-1	SERVO FEED LATCH ASM	133	
-	1	1	1	1	1-18028-2	WASHER, FLAT, REG M4	119	
-	-	REF	-	-	2119944-1	FEED FINGER ASSEMBLY, SF	117	
-	1	1	1	1	455888-4	SPACER, CRIMPER	82	
-	1	1	1	1	22278-7	SPRING, COMPRESSION	77	
-	1	1	1	1	854769-4	HOLDER, INS	74	
-	1	1	1	1	2119956-1	DOCUMENTATION PACKAGE	71	
-	1	-	1	1	2119740-1	TAG, IDENTIFICATION	67	
-	2	2	2	2	2168078-1	SCREW, DRIVE, RH, RoHS, 2 x .188	66	
	1	1	1	1	2119793-1	LIMITER, ADJUSTMENT BOLT	63	
-	3	3	3	3	992763-5	SCR, SET, SOC, CONE POINT, M3 x 4.0	62	
-	-	-	1	1	5-18022-5	SCR, HEX HD CAP, M4 X 6.0	59	
-	1	1	1	1	21028-2	PIN, SLOTTED SPRING .062 X .250	58	
-	-	-	1	1	1338685-1	PAWL, FEED	56	
-	2	2	2	2	1-2168083-0	SCR, SKT HD CAP, RoHS, M4 X 10	53	
-	1	1	1	1	5018030-1	NUT, HEX, REG, RoHS, M3	52	
-	1	1	1	1	811242-5	BUMPER, HOLD DOWN	51	
-	1	1	1	1	690753-6	SPACER, TONKER	50	
-	-	-	1	2	18023-9	SCR, SKT HD CAP M4 X 6.0	49	
-	-	-	-	1	2119652-1	FEED CAM, PRE FEED	48	
-	1	1	1	1	2079383-7	SCR, BHSC, RoHS (M8 X 25)	41	
-	1	1	1	1	2119645-1	DISC, NUMBERED FA WIRE ADJUSTMENT	40	
-	1	1	1	1	2119957-1	APPLICATOR SHIM PACK	39	
-	1	1	1	1	2119644-1	RAM WASHER, PRECISION	38	
-	1	1	1	1	2-1752356-6	SUPPORT, TERMINAL	34	
-	2	2	2	2	2079383-5	SCR, BHSC, RoHS (M4 X 20)	33	
-	1	1	1	1	2161328-1	HEX HEAD, FLANGED, M5 x 8mm LONG	32	
-	1	1	1	1	1320908-2	SPACER, STRIP GUIDE	30	
-	1	1	1	1	2119959-1	ASSEMBLY, STRIP GUIDE	29	
-	1	1	1	1	455888-3	SPACER, CRIMPER	28	
-	1	1	1	1	1320928-2	STRIP GUIDE	24	
-	1	1	1	1	2168083-2	SCR, SKT HD CAP, RoHS, M4 X 8.0	21	
-	1	1	1	1	1-18028-2	WASHER, FLAT, REG M4	20	
-	1	1	1	1	2119533-3	STRIPPER, SIDE FEED	19	
	1	1	1	1	2119806-1	INSERT, SHEAR	13	
-	1	1	1	1	5-22279-1	SPRING, COMPRESSION	12	
-	1	1	1	1	1-356885-4	STOP, SHEAR	11	
	1	1	1	1	2119805-1	SHEAR HOLDER, FRONT	10	
	1	1	1	1	1803418-1	FLOATING SHEAR, MINI COAX FRONT	9	
	1	1	1	1	1803190-6	ANVIL, COMBINATION	8	
-	-	-	-	-	-	-	7	
-	-	-	-	-	-	-	6	
-	1	1	1	1	1803349-1	DEPRESSOR, SHEAR	5	
-	-	-	-	-	-	-	4	
-	-	-	-	-	-	-	3	
-	-	-	-	-	-	-	2	
	1	1	1	1	1	5-1333281-8	CRIMPER, WIRE PREMIUM	1

DIMENSIONS:		TOLERANCES UNLESS OTHERWISE SPECIFIED:		DRAWING NO	
mm	0 PLC ±	1 PLC ±	2 PLC ±	3 PLC ±	4 PLC ±
	ANGLES	FINISH		WEIGHT	
MATERIAL				CUSTOMER DRAWING	

OWN	CHK	APPD	NAME	DATE	REV
R. O. WILSON	J. J. STAKEM	T. ELBIN	Ocean Side Feed Applicator	21OCT2013	3

REVISONS		DATE	DWN	APVD
LOC	DIST			
A	66			
P	LTN	DESCRIPTION		
-	-	SEE SHEET 1	-	-

# FEED TYPE MECHANICAL

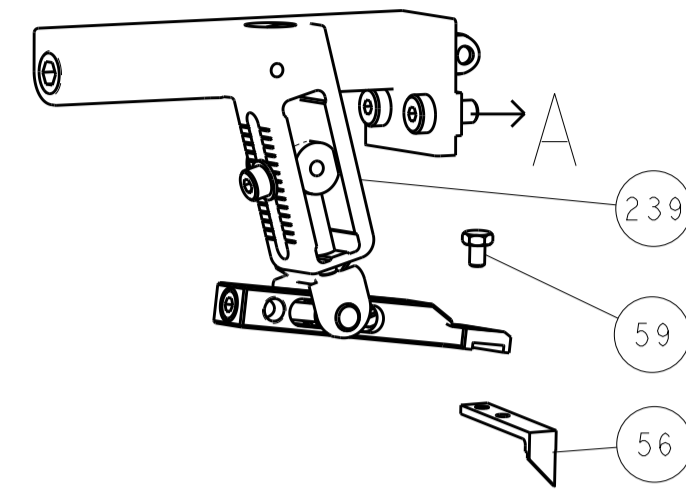

# PNEUMATIC

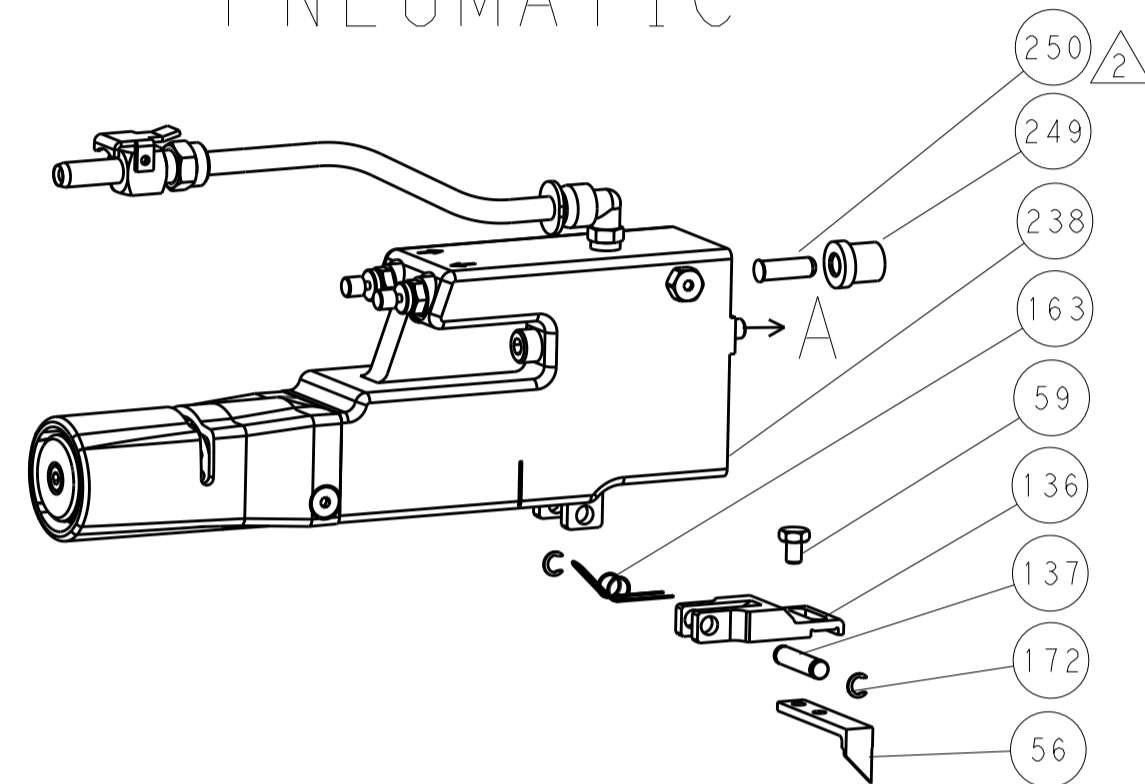

# SERVO LATCH PLATE

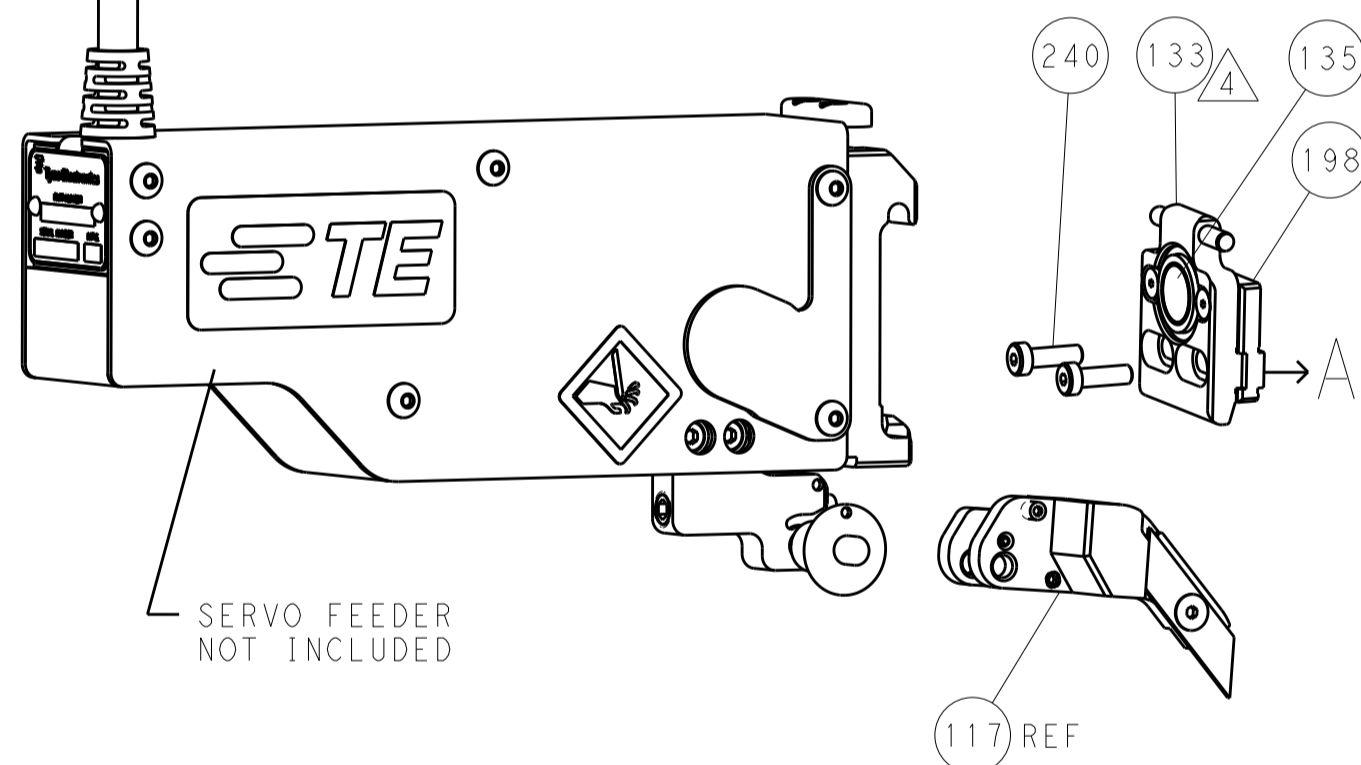

# CAM POSITIONS

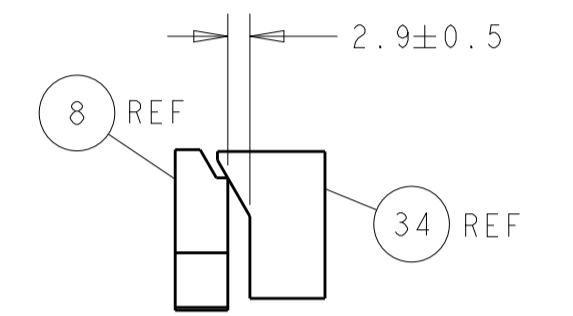
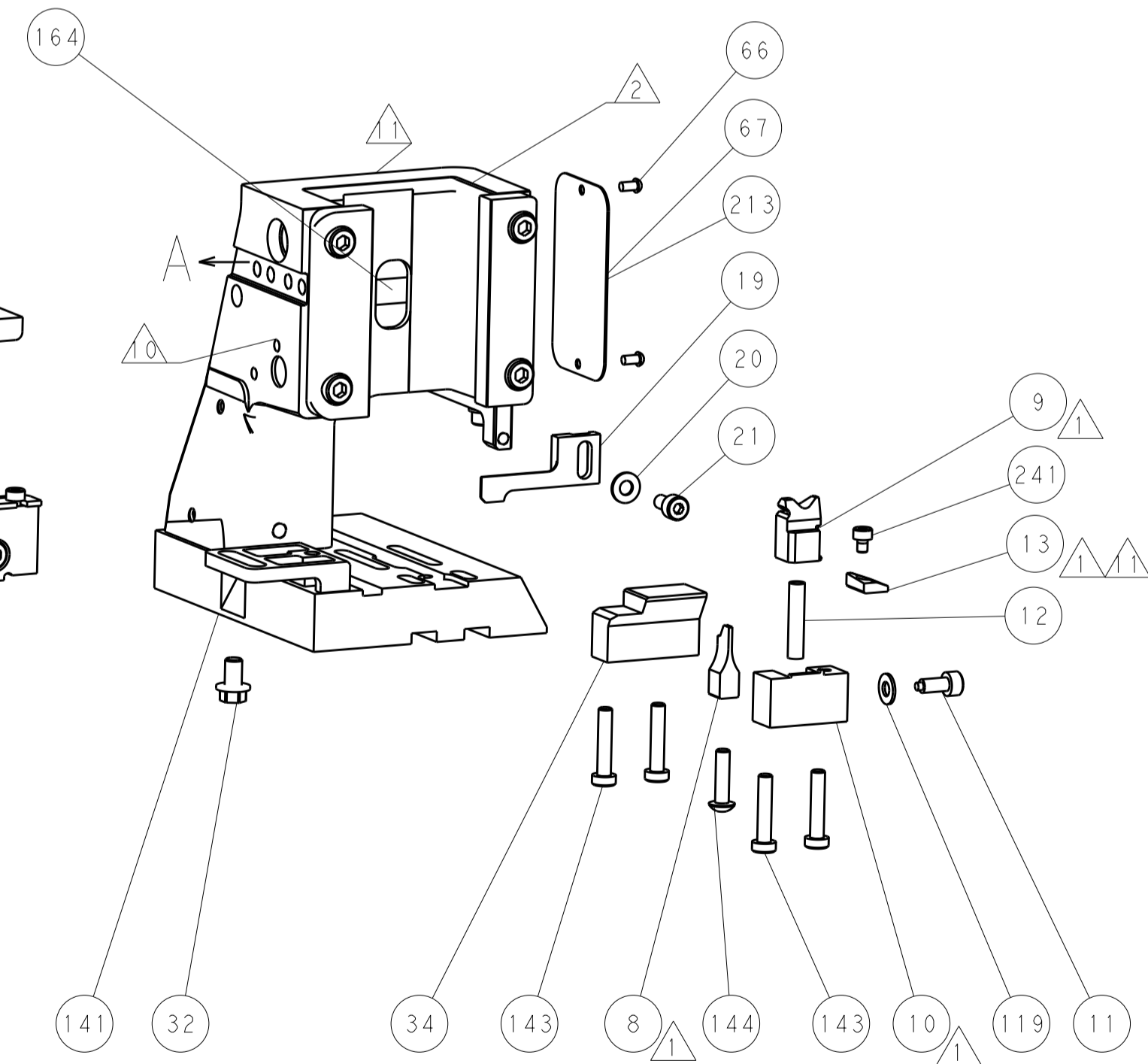
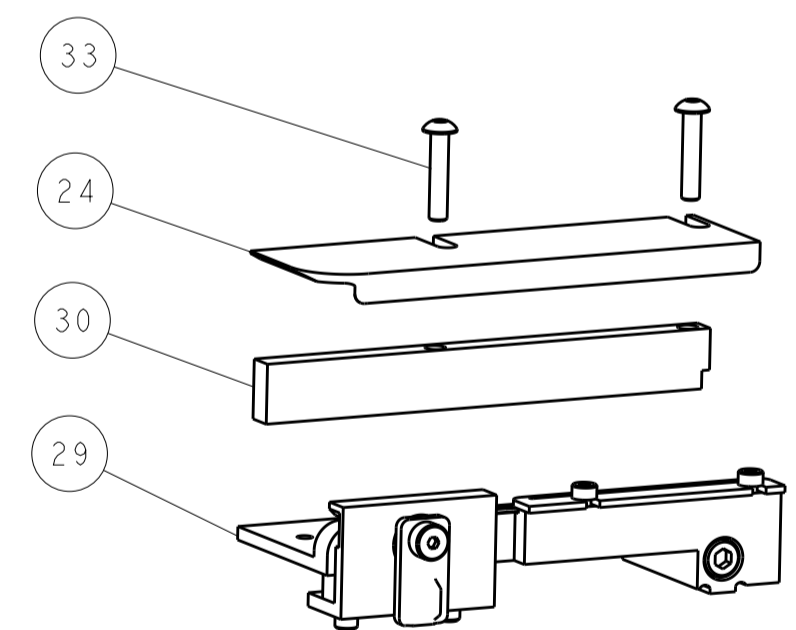
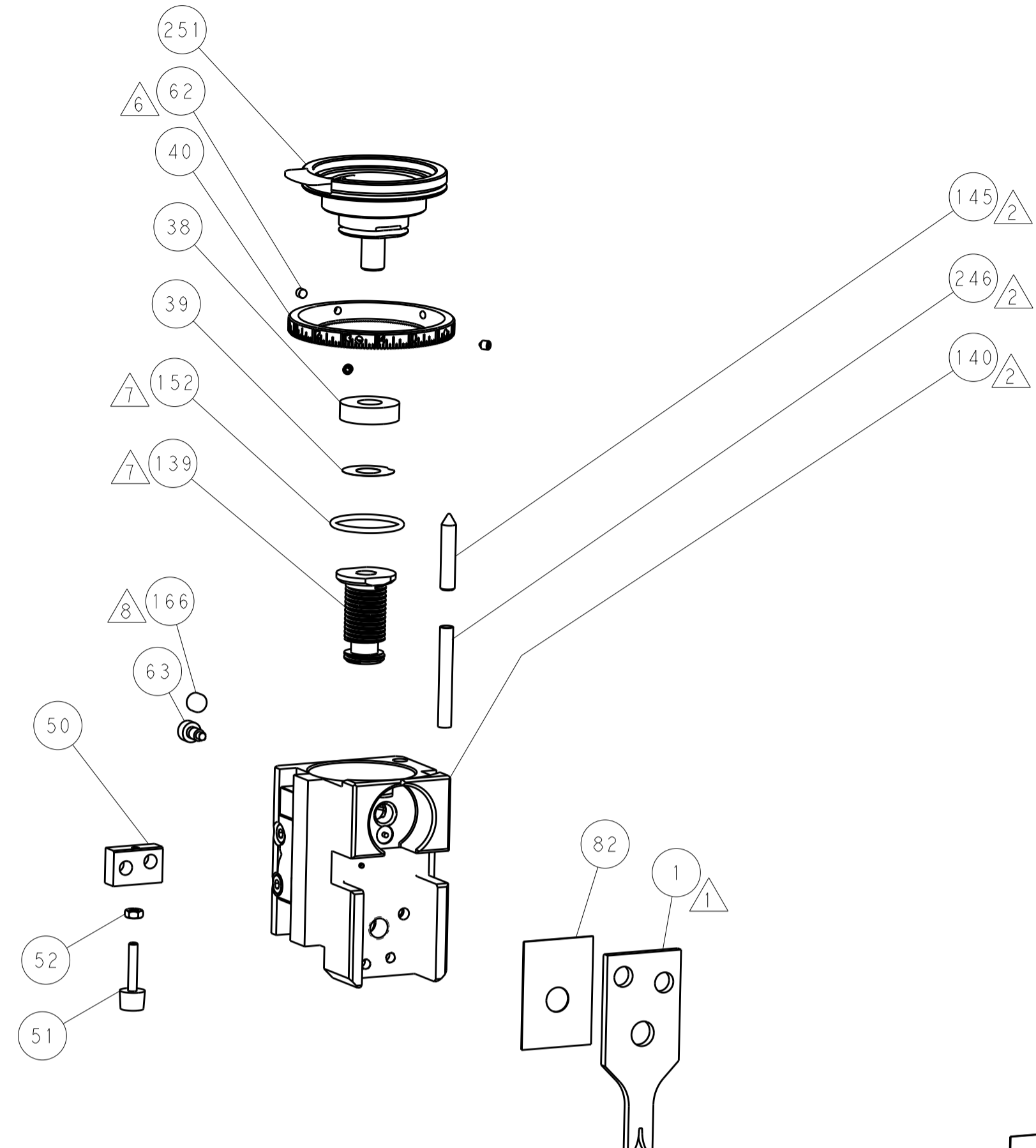
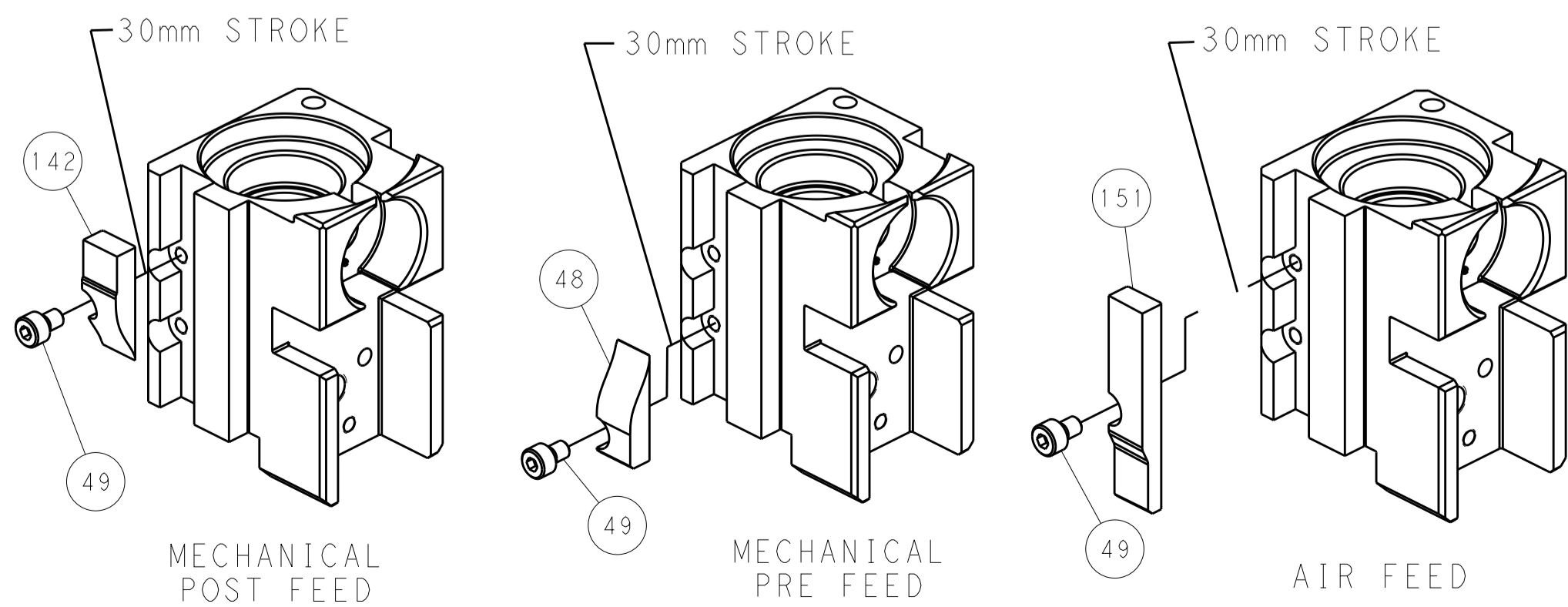

TERMINAL SUPPORT LOCATION

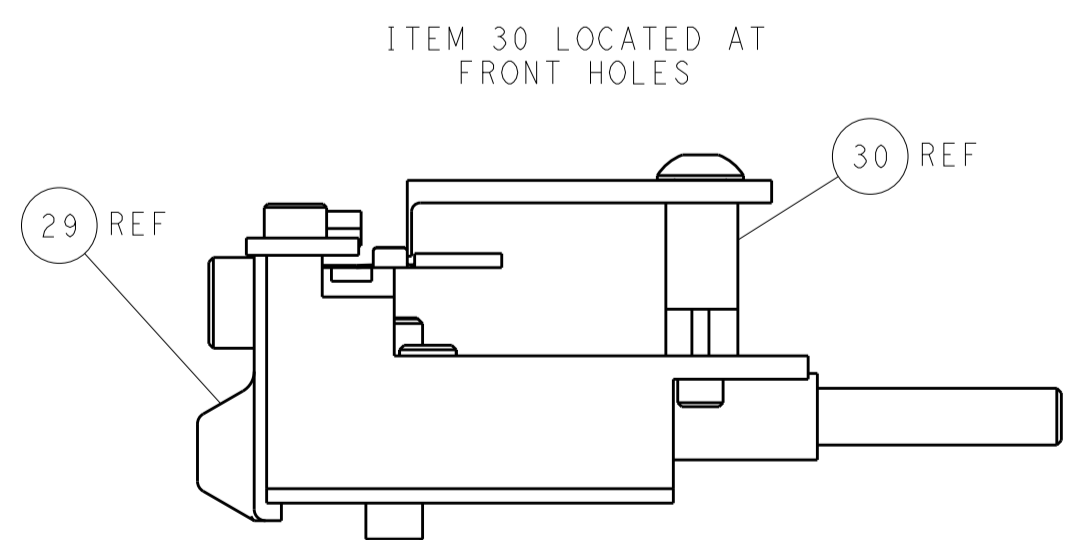

ITEM 30 LOCATED AT FRONT HOLES

FEED TRACK POSITION GUIDE BY WIRE BARREL

**PACIFIC VERSION**  
 Shown on sheets 3 of 4 & 4 of 4  
 (Atlantic version shown on sheets 1 of 4 & 2 of 4)

DIMENSIONS:		TOLERANCES UNLESS OTHERWISE SPECIFIED:		DWN R.O. WILSON 18OCT2013		REVISED	
mm	0 PLC ±	1 PLC ±	2 PLC ±	3 PLC ±	4 PLC ±	5 PLC ±	6 PLC ±
	ANGLES	FINISH		CHK J.J. STAKEM 21OCT2013		NAME	
MATERIAL				APVD T.L. ELBIN 21OCT2013		Ocean Side Feed Applicator	
				PRODUCT SPEC		SIZE CAGE CODE DRAWING NO	
				APPLICATION SPEC		RESTRICTED TO	
				WEIGHT		A1 00779 C=2266047	
				CUSTOMER DRAWING		SCALE 1:2 SHEET 4 OF 4 REV C	